

# NEW IFS C-LEVEL™ SENSOR

## Innovative FLOATLESS Technology

introduces the C-Level™ Sensor  
for use with select Installer Friendly Series® panels.

### C-Level™ Sensor *Multiple Patents Pending*

The C-Level™ sensor detects the liquid level in the tank and sends a signal to the IFS panel, which displays this level in inches or centimeters for easier monitoring of the system. **Pump activation and alarm levels can be adjusted using panel touch pad**, eliminating the need to go into the tank for manual adjustment.

#### C-Level™ Sensor Features:

- Compact design works well in confined space applications
- Operates on low voltage
- One sensor replaces up to 4 floats
- Easy to install and adjust set points
- Works with most Installer Friendly Series® control panels

*See reverse side for complete details on Installer Friendly Series® control panels.*

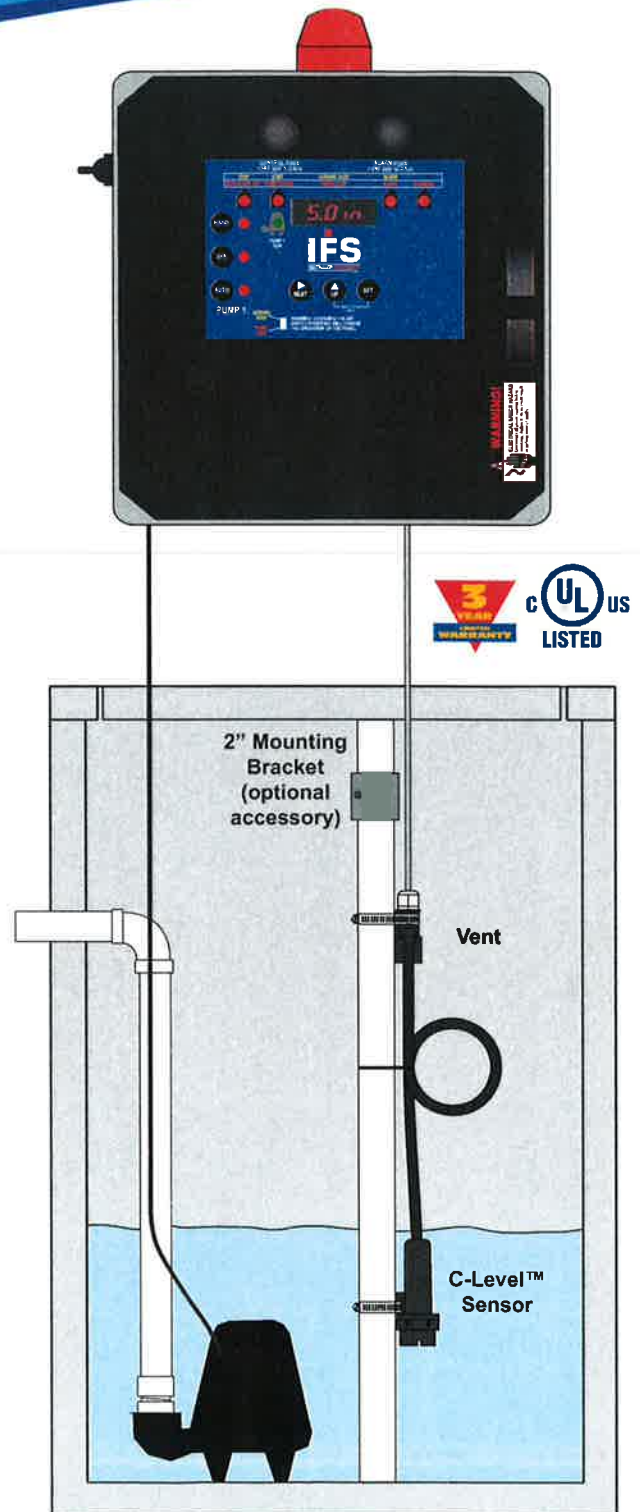

*Float tree not included.*

# Installer Friendly Series® Control Panels

The innovative **Installer Friendly Series®** control panels from SJE-Rhombus® feature an **easy-to-use touch pad** on the inner door for programming and monitoring system information.

- IFS Single Phase Simplex and Duplex Demand/TD
- IFS Three Phase Simplex and Duplex Demand/TD
- IFS Single Phase Capacitor Start/Run Simplex and Duplex
- IFS InSite® Event Monitoring Simplex and Duplex Demand/TD



## IFS PANEL FEATURES:

- NEMA 4X weatherproof enclosure for indoor/outdoor use
- Inner door for added safety
- New innovative circuit board design offers a clean installation
- Separate control and alarm fuses
- Digital display board is standard
- Alarm beacon and horn (85 decibel rating) provides audio/visual warning of alarm condition
- Test / normal / silence switch
- Panel can be easily converted to either demand dose to timed dose in the field
- Easy to read float/pump wiring diagram
- Instruction label on inside cover for viewing and programming digital display
- Includes step-by-step installation instructions

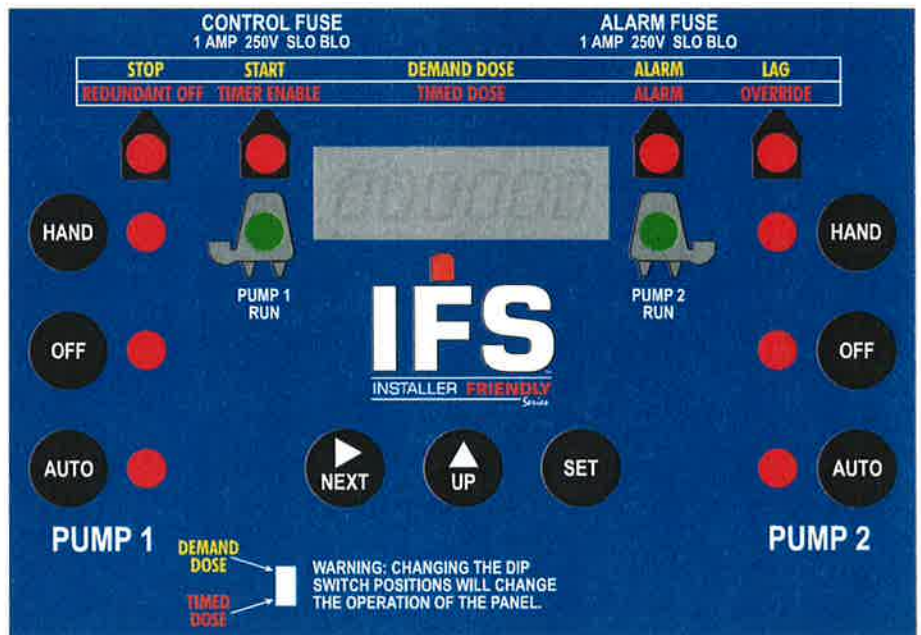

## TOUCH PAD/DISPLAY FEATURES:

- Easy-to-use touch pad for programming pump control
- Pump run indicator(s)
- Status indicators, including low water alarm
- HAND/OFF/AUTO pump control switch(es)
- Hand mode safety feature
- Six digit LED display (now a standard feature) includes:
  - Liquid level in tank in inches or centimeters (C-Level™ Sensor)
  - Elapsed time meter(s)
  - Cycle counter(s)
  - Alarm counter
  - Lead/Lag Selector toggles pump operation (duplex models)
  - Float error counter
  - Override counter (timed dose)