

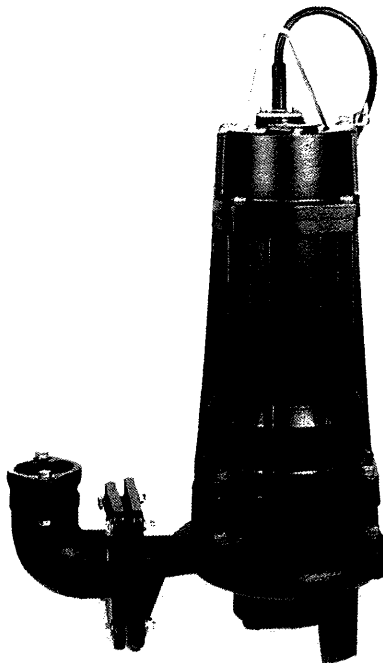

OPERATION & SERVICE MANUAL

FGC-1215/1222 Series
Sewage Grinder Pumps



860, Industrial Blvd.
Bois-des-Filion (Québec) J6Z 4V7

Tel.: (450) 621-2995 Fax: (450) 621-4995

1. PRIOR TO OPERATION

- 1.1. Be sure to provide an adequate grounding and install with leakage breaker to prevent the users from serious electric shock injury.
- 1.2. Make sure the voltage of the power supply are identical to the indications of the nameplate (label) on the pump. Do not plug into other voltage and phase than indicated on the nameplate.
- 1.3. Do not have a dry-run in the air, it will damage the pump.
- 1.4. Do not use the electrical cable to carry, lift or lower the pump. Please carry by the pump handle.
- 1.5. **Extension of power cable:**
When the power cable has to be extended, select the proper cable size within the allowable extension. If cable is extended too far, a drop in voltage may occur, which will stop the running of the motor and damage the pump.

DO NOT USE THE PUMP IN PONDS, SWIMMING POOLS, BATH TUBS, OR ANY OTHER AREA WHERE THERE ARE PEOPLE; SERIOUS ACCIDENTS CAN OCCUR.

2. CARE UNDER OPERATION

- 2.1. **When the pump stops suddenly (by the motor protection device) :**
The motor protection device is built-in and shuts off the circuit automatically to prevent the motor from burning-out when the motor is overloaded due to clogging by foreign particles or when plugged-in to wrong power source (Voltage, Frequency, etc.). Should the pump stop suddenly, please check piping, pump itself, connection of electrical cable to power source, etc. The motor protector always automatically trips-off in a few seconds if there is any abnormality. Please resume the operation after clearing the trouble and leave the pump as it is.
- 2.2. Please consult your local dealer or company from which the pump was purchased if you are unable to solve the problem. Unauthorized personel is prohibited from disassembling or assembling the pump as it will probably result in inferiority in performance or damage to motor.

3. CARE AFTER OPERATION

YOU DO NOT NEED TO TAKE ANY SPECIAL CARE ON THE PUMP AFTER OPERATION, HOWEVER, YOU MUST BE WARN OF THE FOLLOWINGS:

- 3.1. If a freezing temperature is predicted, lift up the pump from water and re-install it in dry condition.
- 3.2. If pump is left in the water for a long period of time without running, rust and other possible floating particals will accumulate in the pump, which will inevitably shorten the life of the pump. In this case, let the pump run in clean water and remove floating particals from inside the pump. Re-install it once dried.

4. APPLICATIONS

THE MOST EFFICIENT, VERSATILE AND COST-EFFECTIVE PRODUCTS YOU'LL EVER USE!

- Reduce all material found in normal domestic, commercial, institutional and light industrial sewage, including plastics, rubber, sanitary napkins, and disposable diapers, into a finely ground slurry. The resultant slurry is then pumped through small diameter piping into a gravity interceptor or treatment facility.
- Recommended for domestic and light commercial.

5. TROUBLE SHOOTING

TO PREVENT SERIOUS ACCIDENTS, DISCONNECT THE POWER SUPPLY BEFORE INSPECTING THE PUMP:

Malfunction	Reason(s)	Countermeasure(s)
Pump fails to start	No power is supplied (power outage)	Contact the electric power company or an electrical repair shop
	Open circuit or poor connection of the cabtyre cable	Check if there is an open circuit in the cabtyre cable or wiring
	Impeller is obstructed	Inspect the pump and remove the obstruction
Pump starts but stops immediately, causing the motor protector to actuate	Impeller is obstructed	Inspect the pump and remove the obstruction
	Voltage drop	Correct the voltage to the rated voltage, or use an extension cable that meets the standard
	A 50Hz model is operated at 60Hz	Check the nameplate and replace the pump or impeller
	The strainer is obstructed, and the pump was operated dry for long hours	Remove the obstruction
	Motor abnormal	Repair the motor or replace with a new motor
	The pump is picking up too much sediment	Place a concrete block under the pump to prevent the pump from picking-up sediment
The pump's head and pumping volume is lower	The impeller is worn	Replace
	The hose may be clogged	Minimize the number of bends in the hose, (in an area with a large amount of debris, use the pump in a meshed basket)
	The strainer is obstructed or buried	Remove the obstruction. Place a concrete block under the pump to prevent the pump from picking-up sediment
	The motor rotates in reverse	Interchange the power supply terminal connection
The pump generates noise or vibration	The bearing of the motor may be damaged	To replace the bearing, contact the dealer from whom you purchased the equipment

6. SERVICE AND WARRANTY

If you can not find the reasons of the problem, please consult the authorized local dealer or company from which the pump was purchased. The pump has a 1 year warranty from the invoice date. Invoice is required for any warranty work.

7. TECHNICAL SPECIFICATIONS

Models Modèles	Outlet Sortie		Elec. Motor Moteur élec.				Voltage / Phase / HZ	Weight Poids	
	mm mm	in po	Hp Hp	Amp. / Amp.		kg kg		lbs lb	
				Start Départ	Run Opération				
FGC-1215	32	1 1/4	2	70	20	115/1/60	43	95	
FGC-1215	32	1 1/4	2	36	10.58	220/1/60	43	95	
FGC-1215	32	1 1/4	2	24	6.35	208/3/60	43	95	
FGC-1215	32	1 1/4	2	22.5	5.9	230/3/60	43	95	
FGC-1215	32	1 1/4	2	12.1	2.87	460/3/60	43	95	
FGC-1215	32	1 1/4	2	13	2.68	480/3/60	43	95	
✗ FGC-1215	32	1 1/4	2	15	2.3	575/3/60	43	95	
FGC-1222	32	1 1/4	3	40.5	8.9	208/3/60	43	95	
FGC-1222	32	1 1/4	3	41.2	8.7	230/3/60	43	95	
FGC-1222	32	1 1/4	3	20.5	4.2	460/3/60	43	95	
FGC-1222	32	1 1/4	3	21	4.1	480/3/60	43	95	
FGC-1222	32	1 1/4	3	12	3	575/3/60	43	95	

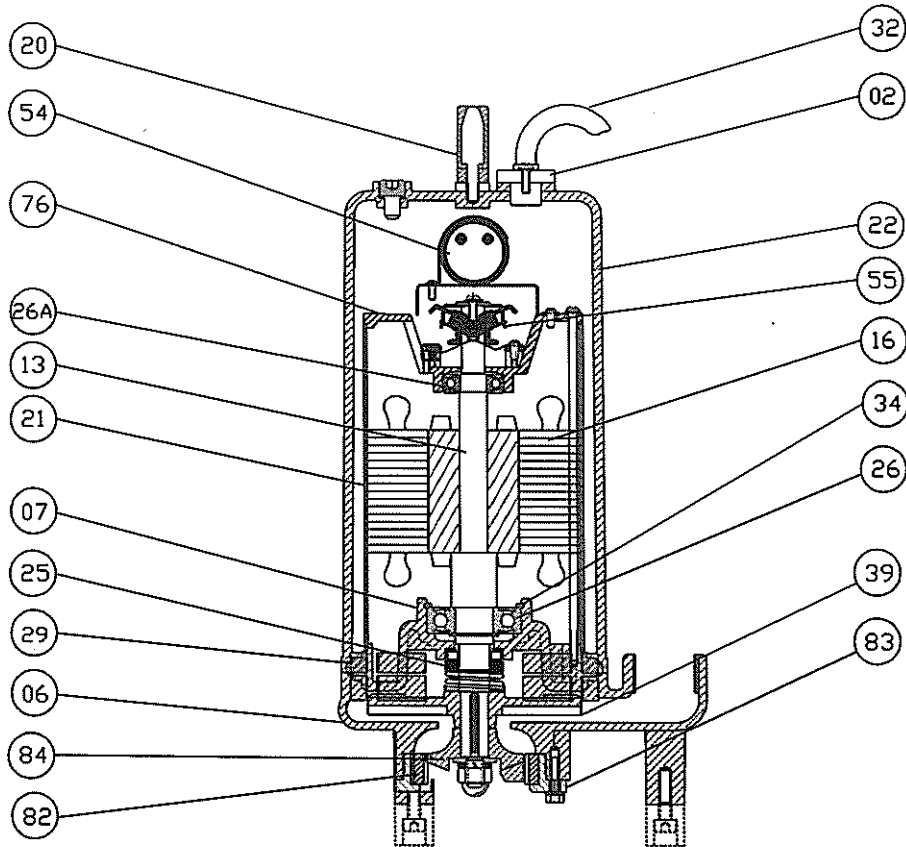
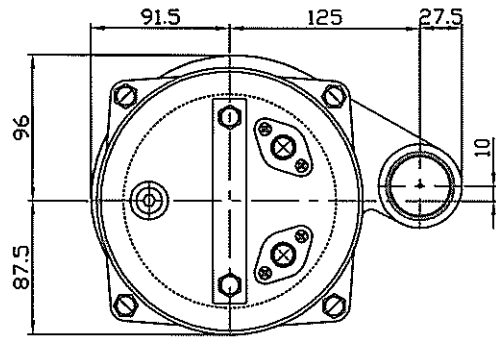

FGC-015(60Hz)-Parts List

No.	Description	Material	Q'ty	Remarks ?
02	Cable Gland	NBR	1	
06	Volute	FC-20	1	
07	Bearing bracket	FC-20	1	
13	Shaft	SUS-410	1	
16	Stator		1	
20	Handle	SC	1	
21	Motor frame	SC	1	
22	Outer case	FC-20	1	
25	Mech seal	ASIC/SIC	1	20mm
26	Bearing	6305ZZ*C3	1	
26A	Bearing	6303ZZ*C3	1	
29C	Gasket	NBR	1	
32	Cable	SJTW	1	
34	C-ring	SC-40	1	
39	Impeller	FCD-45	1	
54	Capacitor		1	250V-300MFD
55	Cetr. switch		1	
76	Bearing bracket	AC	1	
82	Shredder ring	HCR	1	
83	Ring holder	FC-20	1	
84	Shredder	HCR	1	