

# FLO FAB

FF

## Constant Pressure Systems

### Series CPS-880



[www.flofab.com](http://www.flofab.com)

Manufacturer of Pumps, Tanks, Heat Exchangers & Accessories  
for HVAC Market After-Sales Parts and Services

Constant Pressure Systems:  
Series CPS-880

FLO FAB INC  
LAKE WORTH,  
FLORIDA, USA

## Index

<b>Subjects</b>	<b>Pages</b>
<b>Description.....</b>	<b>1</b>
<b>Features.....</b>	<b>2</b>
<b>System Sizing Guide.....</b>	<b>3</b>
<b>Model Selection Pattern.....</b>	<b>4</b>
<b>Model Selection .....</b>	<b>5</b>
<b>Hydropneumatic Tanks Sizes.....</b>	<b>6</b>
<b>S-CPS Selection Tables.....</b> <small>(Simplex)</small>	<b>7</b>
<b>D-CPS (T-CPS) Selection Tables 3450 RPM.....</b> <small>(Duplex)                      (Triplex)</small>	<b>8-11</b>
<b>D-CPS (T-CPS) Selection Tables 1750 RPM.....</b> <small>(Duplex)                      (Triplex)</small>	<b>12-15</b>



Series 880

### FLO FAB Series 880 Pump

High efficiency centrifugal pumps are used on all models. Pumps are bronze fitted, with dripless mechanical shaft seals and casing wearings as standard construction. Pump impellers are statically and dynamically balanced for smooth operation. Closed coupling of the pump and motor eliminates alignment problems and reduces shaft deflection.

(Horizontal in-line series 1000 also available as optional)

### Pressure Regulating Valve (PRV-C)

Combination pressure regulating and non-slam check valves are used with each system pump when specified. Valves are hydraulically operated, pilot controlled, diaphragm type globe valves. High and fluctuating suction pressures are automatically reduced to steady the downstream pressures regardless of the changing flow rates. Check valve senses pressure reduction when the pump is stopped and automatically to prevent reverse flow.

(By-pass valve optional)

### Control Panel

Every FLO FAB control panel is manufactured to match the specific system design conditions. Standard control panel includes circuit breakers, magnetic starters with overload protection on all phases, hand-off automatic selector switches and running lights for each motor, 115 volt control circuit, and necessary relays and time delays pre-wired in a general purpose NEMA I enclosure integrated into the utilized assembly. All electrical wiring is in accordance with the National Electrical Code. Every panel is factory wired and pre-tested under rigorous quality control conditions to assure trouble-free operation. Dead bolt, vandal resistant NEMA III weather proof enclosure also available for outdoor installation.

Automatic 24 hour alternator and variable speed panels also available.

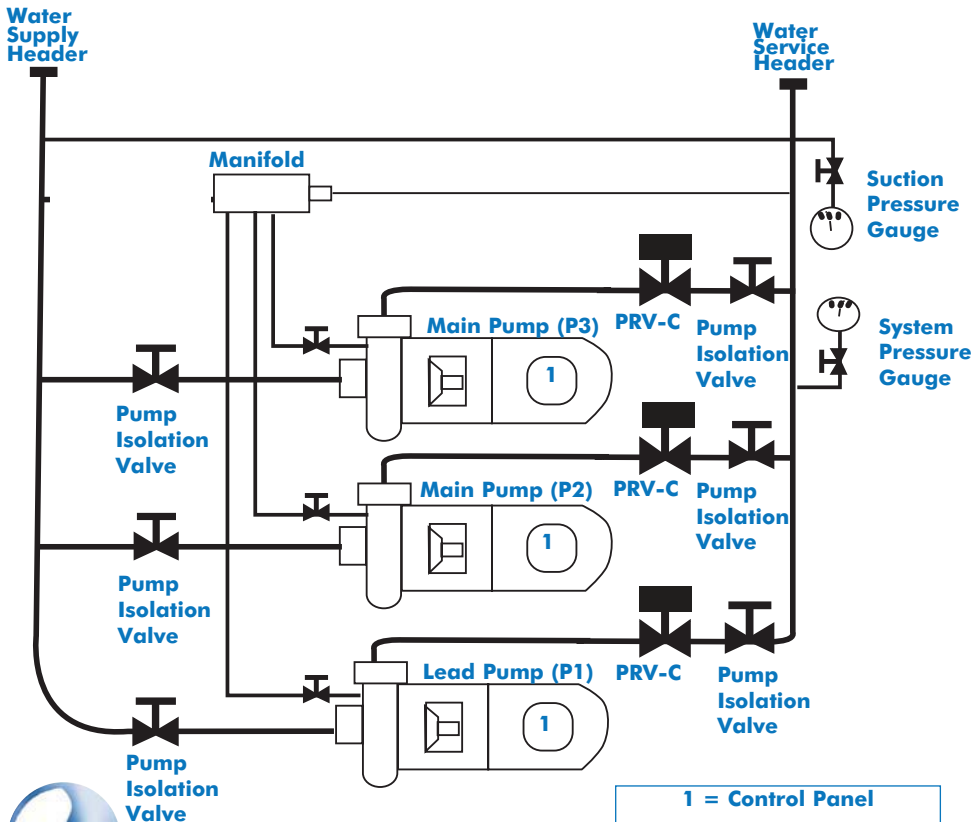

### Schematic Diagram

- Simplex** S-CPS-880
- Duplex** D-CPS-880
- Triplex** T-CPS-880



## Features

### Low Cost

Low Initial Cost:

Power Saving:

Low Installation Cost:

Adjustment free:

As standard components are used through the complete line of prefab systems.

Multiple pump unit permits use of smaller pumps operating in the best efficiency range.

Factory assembly simplifies the installation.

Unit is thoroughly inspected, tested and adjusted before shipping.

### Reliable

Virtually Constant Pressure:

Perfect Parallel Operation:

Safe Shut-Off Operation:

Each system, is designed to absorb all erratic pressure surges.

Through use of a by-pass or pressure reducing valves (where specified).

Cooling coil dissipates heat when generated. No demand bleed gives additional protection against excessive rise temperature.

Throughout Shop Test Procedure:

Tested for vibration, over-heating, leakage, pump and motor performance, electrical circuitry and final pressure setting.

Undivided System Responsibility:

All components are sized and calibrated by experienced pump technicians.

Control Center:

Incorporates all necessary controls, safety features, for full protection.

System Shut Down:

Shut-down for extended period of no flow is made possible through an hydropneumatic tank, as optional

### Almost NO Maintenance

No Lubrication:

None necessary on pumps (some motors do require lubrication depending on motor suppliers)

Maximum Shaft Seal Life:

Ensured through the use of vibration free closed coupled pumps.

### Quiet System

Pressure Reducing And Check Valves:

Eliminate water hammer.

Short Shaft:

On closed coupled pumps, reduces shaft deflection and vibration.

Optimum Clearance at Cut Water:

Eliminates hydraulic noise.

Straight Through Piping:

Eliminates noisy elbows and turbulence.

Oversize Suction And Discharge

Stainless Steel Headers:

Eliminate major sources of noise.

### Space Saver

Minimum Width:

All units are designed to go through standard door (34") (up to 15 Hp).

Fits Against A Wall:

All controls, pumps, motors and accessories are accessible and serviceable from the front.

## Installation

### Quick System Selector

#### Basic Standard Components

- Silent Check Valve(s)
- No Demand Bleed
- Low Suction Pressure Cut-Out
- Across The Line Starter(s)
- Close Coupled Pump(s)

#### Optional Components

- By-Pass Relief Valve
- Pressure Reducing and Check Valve(s)
- Hydropneumatic Tank  
(Model D-CPS-880-HT)
- Reduced Voltage Starter(s)
- Horizontal In-Line Pump(s)
- Suction Tank
- Variable Speed Control Panel



## System Capacity

The system capacity can be determined by using **Figure 1**. This chart assigns a value to each individual fixture. The most common fixtures and their flow unit values are listed. Add the total fixture flow unit value for all fixtures. Also, add any extra water demands planned.

Using the **Figure 2** select the system USGPM.

**Fixture Flow Unit Table (Fig.1)**

Fixtures	Public Commercial (1)	Semi Public (2)	Private (3)
<b>Water Closet</b>			
Flush Valve	10	8	6
Flush Tank	5	4	3
<b>Urinal</b>			
Flush Valve, Pedestrial	10	8	--
Flush Valve, Stall or Wall	5	4	3
Flush Tank	3	2	--
<b>Bathtub</b>			
Standard	4	3	2
Emergence	4	--	--
Immersion	20	--	--
<b>Shower</b>			
Standard	4	3	2
Emergence	8	8	--
<b>Lavatory</b>	2	1	1
<b>Bathroom Group</b>			
W.C. Lav. and Tub/Shower	--	--	--
Flush Valves	--	--	8
Flush Tank	--	--	6
<b>Sink</b>			
Kitchen	4	3	2
General	3	2	--
Service	4	3	2
Laboratory	--	2	--
Bar	3	2	--
<b>Dishwasher</b>			
General	6	4	2
Pot and Pan	3	3	--
Garbage Disposal, Sink	3	3	2
Washing Machine	--	6	4
Laundry Tub	--	3	2
Drinking Fountain	2	1	1
Ice Cube Machine	1	1	1
Steamtables	1	1	--
Hose Connection, 3/4"	--	4	4
Fire Sprinkler	10	10	--

**Fixture Conversion Chart (Fig.2)**

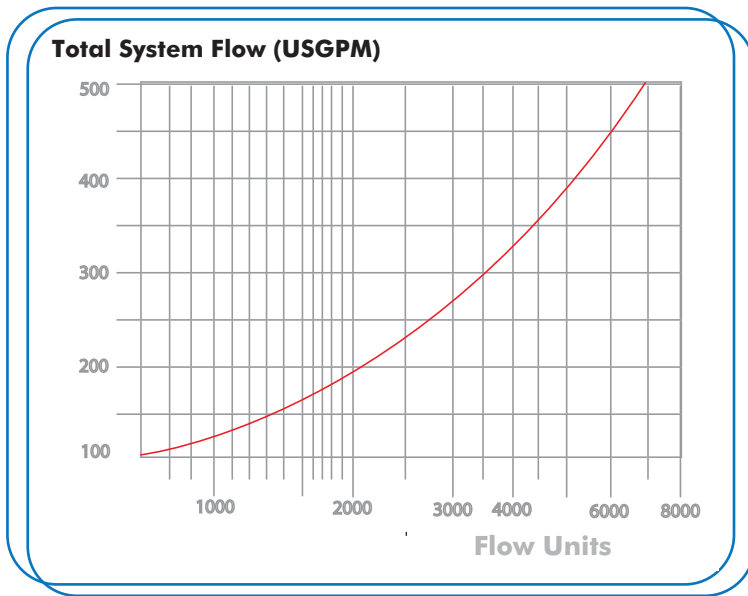

(1) Public Commercial Classified as public buildings: Hospitals, Hotels, Factories, Departement Stores, Theaters, Restaurants, etc.

(2) Semi Public Classified as office Buildings, Clubs, Rooming Houses, Motels, etc.

(3) Private Homes, Apartments, Private Offices.

## System Boost

The following factors must be considered in determining the system boost requirements:

- 1) Determine the maximum elevation water to be boosted \_\_\_\_\_ ft.
- 2) Add building system friction loss at capacity flow \_\_\_\_\_ ft.
- 3) Add the pressure to be maintained at the most distant point \_\_\_\_\_ PSI x 2.31 \_\_\_\_\_ ft.
- 4) Deduct minimum suction pressure available at system suction \_\_\_\_\_ PSI x 2.31 \_\_\_\_\_ ft.

System Boost Requirement is \_\_\_\_\_ ft.

**Note: Specify maximum suction pressure to determine proper pump working pressure.**

## Selecting a S-CPS System (Simplex Constant Pressure System)

Model Number Details:

Example: The model selected will be detailed as: S-CPS-880-3x3x8-5

Booster Pressure PSI	Head Feet	USGPM 160	
		USGPM	Hp
20	45	3x3x8	5
30	70	3x3x10	5

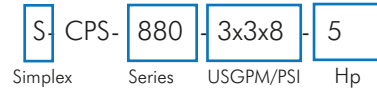

## Selecting a D-CPS or T-CPS System (Duplex or Triplex Constant Pressure System)

Model Number Details:

Example:

**Based on 3450 RPM**

Unit Model Number	Pump Capacity USGPM	Head PSI	Head Feet	P1 Pump (Hp)	P2 Pump (Hp)	Header		P1 Pump Model	P2 Pump Model
						Flow	Size		
90/40	P1 30 P2 60 System 90	40	95	5	5	0-300	3"	2x2x8LF	2x2x8LF
90/50		50	115	5	5			2x2x8LF	2x2x8LF
90/60									

The model selected will be detailed as: D-CPS-880-90/40

Duplex D - CPS - 880 - 90/40

Series      System USGPM/PSI

**OR**

Triplex T - CPS - 880 - 90/40

Series      System USGPM/PSI

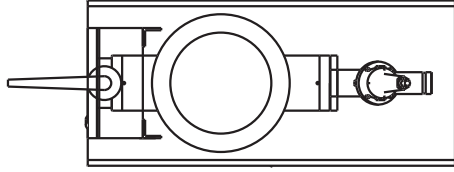

S-CPS-880 □

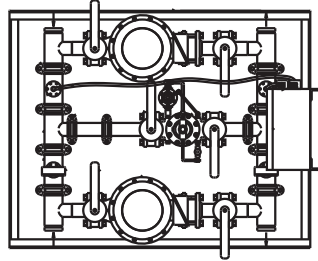

D-CPS-880 □

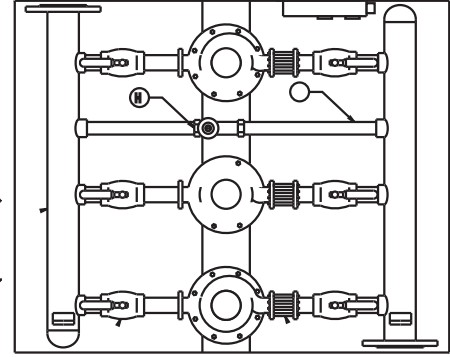

T-CPS-880 □

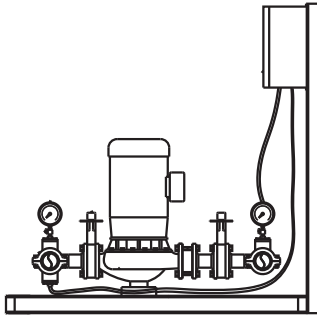

S-CPS-880 □

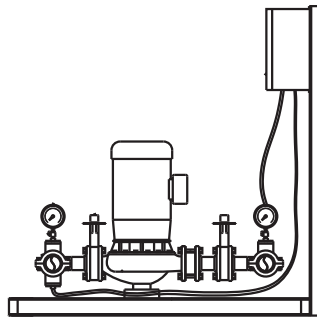

D-CPS-880 □

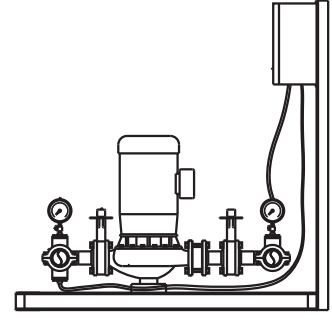

T-CPS-880 □

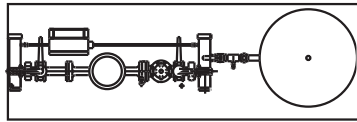

S-CPS-880-HT □

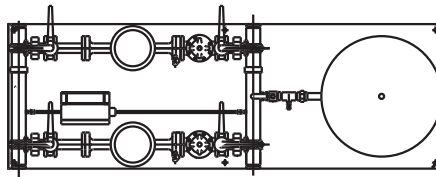

D-CPS-880-HT □

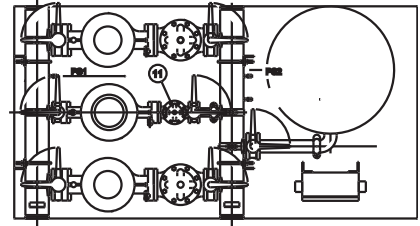

T-CPS-880-HT □

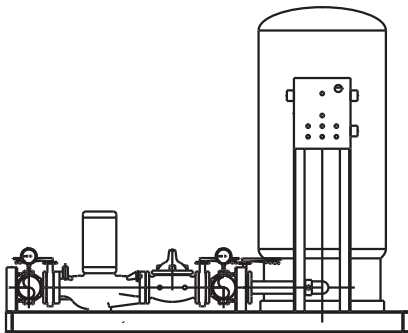

S-CPS-880-HT □

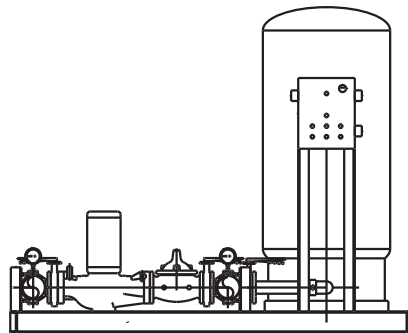

D-CPS-880-HT □

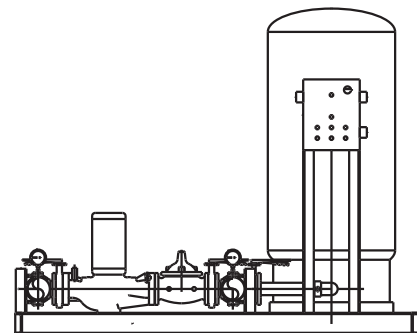

T-CPS-880-HT □

## REPLACEABLE BLADDER HYDROPNEUMATIC TANK WITH BOTTOM SYSTEM CONNECTION



- Constructed in accordance with the ASME, Section VIII, Div. 1
- Constructed in accordance with CSA B.51
- Designed pressure of 125 PSI (862 kPa)
- Designed temperature of 240°F (115°C)
- Carbon steel construction
- Butyl replaceable bladder
- Galvanized Carbon steel bottom system connection (for better efficiency)

### DIMENSIONS

Models	Total Volume		A X B		C		D (NPT)		Weight	
	gal	L	in X in	mm X mm	in	mm	in	mm	Lbs	kg
PBT-160V	42	160	24 X 38	610 X 965	2	50	1 1/2	25	305	139
PBT-200V	53	200	24 X 43	610 X 1092	2	50	1 1/2	25	325	148
PBT-250V	66	250	24 X 50	610 X 1270	2	50	1 1/2	25	350	159
PBT-300V	79	300	24 X 57	610 X 1448	2	50	1 1/2	25	380	173
PBT-400V	106	400	24 X 70	610 X 1778	2 1/2	64	2	32	435	198
PBT-500V	132	500	24 X 83	610 X 2108	2 1/2	64	2	32	485	220
PBT-600V	159	600	30 X 69	762 X 1753	2 1/2	64	2 1/2	32	535	243
PBT-800V	211	800	30 X 87	762 X 2210	2 1/2	64	2 1/2	32	625	284
PBT-1000V	264	1000	36 X 81	914 X 2057	3	76	3	38	803	365
PBT-1200V	317	1200	36 X 93	914 X 2362	3	76	3	38	905	411
PBT-1400V	370	1400	36 X 104	914 X 2642	3	76	3	38	995	452
PBT-1600V	423	1600	48 X 82	1220 X 2083	6 1/2	165	4	50	1290	586
PBT-2000V	528	2000	48 X 95	1220 X 2413	6 1/2	165	4	50	1465	666
PBT-2500V	660	2500	48 X 112	1220 X 2845	6 1/2	165	4	50	1690	768
PBT-3000V	793	3000	48 X 129	1220 X 3277	6 1/2	165	4	50	1920	872
PBT-4000V	1057	4000	60 X 118	1524 X 2997	7 1/2	191	6	64	2850	1295
PBT-5000V	1321	5000	60 X 139	1524 X 3531	7 1/2	191	6	64	3280	1491

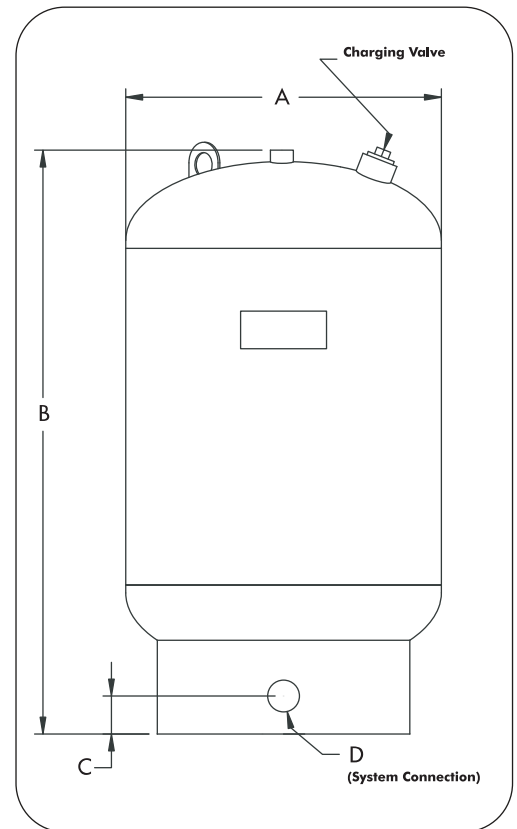



# FLO FAB S-CPS Selection Tables (Simplex)

Simplex Series S-CPS-880

Booster Pressure PSI	Head Feet	USGPM 30		USGPM 40		USGPM 50		USGPM 60	
			Hp		Hp		Hp		Hp
30	70					2x2x8	5	2x2x8	5
40	95	2x2x8LF	5	2x2x8	5	2x2x8	5	2x2x8LF	5
50	115	2x2x8LF	5	2x2x8	7 1/2	2x2x8LF	5	2x2x8LF	5
60	140	2x2x8LF	5	2x2x8LF	7 1/2	2x2x8LF	5	2x2x8LF	7 1/2
70	160	2x2x8LF	5	2x2x8LF	7 1/2	2x2x8LF	7 1/2	2x2x8LF	7 1/2
80	185	2x2x8LF	7 1/2	2x2x8LF	7 1/2	2x2x8LF	10	2x2x8LF	10
90	210	2x2x8LF	10	2x2x8LF	10	2x2x8LF	10	2x2x8LF	10
100	230	2x2x8LF	15	2x2x8LF	10	2x2x8LF	15	2x2x8LF	15

3450 RPM

Booster Pressure PSI	Head Feet	USGPM 70		USGPM 80		USGPM 90		USGPM 100		USGPM 120		USGPM 125		USGPM 150	
			Hp		Hp		Hp		Hp		Hp		Hp		Hp
30	70	2x2x8	5	2x2x8	5	2x2x8	5	2x2x8	5	2x2x8	5	2x2x8	5	2x2x8	5
40	95	2x2x8LF	5	2x2x8LF	5	2x2x8	7 1/2	2x2x8	7 1/2	2x2x8	7 1/2	2x2x8	7 1/2	2x2x8	7 1/2
50	115	2x2x8LF	5	2x2x8LF	5	2x2x8LF	7 1/2	2x2x8	7 1/2	2x2x8	7 1/2	2x2x8	7 1/2	2x2x8	10
60	140	2x2x8LF	7 1/2	2x2x8LF	7 1/2	2x2x8LF	7 1/2	2x2x8LF	7 1/2	2x2x8	10	2x2x8	10	2x2x8	10
70	160	2x2x8LF	7 1/2	2x2x8LF	7 1/2	2x2x8LF	10	2x2x8LF	7 1/2	2x2x8	15	2x2x8	15	2x2x8	15
80	185	2x2x8LF	10	2x2x8LF	10	2x2x8LF	10	2x2x8LF	10	2x2x8LF	15	2x2x8	15	2x2x8	15
90	210	2x2x8LF	10	2x2x8LF	15	2x2x8LF	15	2x2x8LF	15	2x2x8LF	15	2x2x8LF	15	2x2x10	25
100	230	2x2x8LF	15	2x2x8LF	15	2x2x8LF	15	2x2x8LF	15	2x2x10	25	2x2x10	25	2x2x10	25

3450 RPM

Booster Pressure PSI	Head Feet	USGPM 60		USGPM 70		USGPM 80		USGPM 90		USGPM 100		USGPM 120		USGPM 140	
			Hp		Hp		Hp		Hp		Hp		Hp		Hp
20	45	2x2x8LF	1 1/2	2x2x8	2	2x2x8	2	2x2x8	2	2x2x8	2	2x2x8	3	3x3x8	5
30	70	2x2x10	5	2x2x10	5	2x2x10	5	2x2x10	5	2x2x10	5	2x2x10	5	2x2x10	5
40	95	2x2x10	7 1/2	3x3x12	15	3x3x12	15	3x3x12	15					3x3x12	20
50	115														
60	140														
70	160														

1750 RPM

Booster Pressure PSI	Head Feet	USGPM 160		USGPM 180		USGPM 200		USGPM 250		USGPM 300		USGPM 350		USGPM 400		USGPM 450	
			Hp		Hp		Hp		Hp		Hp		Hp		Hp		Hp
20	45	3x3x8	5	3x3x8	5	3x3x8	5	3x3x8	5	4x4x10	5						
30	70	3x3x10	7 1/2	3x3x10	7 1/2	3x3x10	7 1/2	4x4x10	7 1/2	4x4x10	7 1/2						
40	95	3x3x12	20	3x3x12	20	3x3x12	20	3x3x12	20	3x3x12	20						
50	115																
60	140																
70	160																

1750 RPM

# D-CPS Selection Tables (Duplex)



Based on 3450 RPM

Series 880

Unit Model Number	Pump Capacity USGPM	Head PSI	Head Feet	P1 Pump (Hp)	P2 Pump (Hp)	Header		P1 Pump Model	P2 Pump Model
						Flow	Size		
90/20	P1 30	20	45	-----	-----	0-300	3"	-----	-----
90/30		30	70	-----	-----			-----	-----
90/40		40	95	5	5			2 x 2 x 8 LF	2 x 2 x 8 LF
90/50	P2 60	50	115	5	5			2 x 2 x 8 LF	2 x 2 x 8 LF
90/60		60	140	5	7 1/2			2 x 2 x 8 LF	2 x 2 x 8 LF
90/70		70	160	5	7 1/2			2 x 2 x 8 LF	2 x 2 x 8 LF
90/80	System 90	80	185	7 1/2	7 1/2			2 x 2 x 8 LF	2 x 2 x 8 LF
90/90		90	210	10	10			2 x 2 x 8 LF	2 x 2 x 8 LF
90/100		100	230	15	15			2 x 2 x 8 LF	2 x 2 x 8 LF
120/20	P1 40	20	45	-----	-----			0-300	3"
120/30		30	70	-----	-----	-----	-----		
120/40		40	95	5	5	2 x 2 x 8	2 x 2 x 8		
120/50	P2 80	50	115	7 1/2	7 1/2	2 x 2 x 8	2 x 2 x 8		
120/60		60	140	7 1/2	10	2 x 2 x 8 LF	2 x 2 x 8		
120/70		70	160	7 1/2	10	2 x 2 x 8 LF	2 x 2 x 8 LF		
120/80	System 120	80	185	7 1/2	10	2 x 2 x 8 LF	2 x 2 x 8 LF		
120/90		90	210	10	10	2 x 2 x 8 LF	2 x 2 x 8 LF		
120/100		100	230	10	15	2 x 2 x 8 LF	2 x 2 x 8 LF		
150/20	P1 50	20	45	-----	-----	0-300	3"		
150/30		30	70	5	5			2 x 2 x 8	2 x 2 x 8
150/40		40	95	5	7 1/2			2 x 2 x 8	2 x 2 x 8
150/50	P2 100	50	115	5	7 1/2			2 x 2 x 8 LF	2 x 2 x 8
150/60		60	140	5	7 1/2			2 x 2 x 8 LF	2 x 2 x 8 LF
150/70		70	160	7 1/2	10			2 x 2 x 8 LF	2 x 2 x 8 LF
150/80	System 150	80	185	10	10			2 x 2 x 8 LF	2 x 2 x 8 LF
150/90		90	210	10	15			2 x 2 x 8 LF	2 x 2 x 8 LF
150/100		100	230	15	15			2 x 2 x 8 LF	2 x 2 x 8 LF

## PRV

D-Duplex (D-CPS- Series-Pump Model)

For triplex System take pump P-2 twice  
T-Triplex (T-CPS- Series-Pump Model)

Sizes	Minimum Flow USGPM	Maximum Flow USGPM
2	15	208
3	35	460





# FLO FAB D-CPS Selection Tables (Duplex)

Based on 3450 RPM

Series 880

Unit Model Number	Pump Capacity USGPM	Head PSI	Head Feet	P1 Pump (Hp)	P2 Pump (Hp)	Header		P1 Pump Model	P2 Pump Model
						Flow	Size		
180/20	P1 60	20	45	-----	-----	0-300	3"	-----	-----
180/30		30	70	5	5			2 x 2 x 8	2 x 2 x 8
180/40		40	95	5	7 1/2			2 x 2 x 8 LF	2 x 2 x 8
180/50		P2 120	50	115	5			7 1/2	2 x 2 x 8 LF
180/60	60		140	7 1/2	10			2 x 2 x 8 LF	2 x 2 x 8
180/70	70		160	7 1/2	15			2 x 2 x 8 LF	2 x 2 x 8
180/80	System 180		80	185	10			15	2 x 2 x 8 LF
180/90		90	210	10	15			2 x 2 x 8 LF	2 x 2 x 8 LF
180/100		100	230	15	25			2 x 2 x 8 LF	2 x 2 x 10
210/20	P1 70	20	45	-----	-----	0-300	3"	-----	-----
210/30		30	70	5	5			2 x 2 x 8	2 x 2 x 8
210/40		40	95	5	7 1/2			2 x 2 x 8 LF	2 x 2 x 8
210/50		P2 140	50	115	5			7 1/2	2 x 2 x 8 LF
210/60	60		140	7 1/2	10			2 x 2 x 8 LF	2 x 2 x 8
210/70	70		160	7 1/2	15			2 x 2 x 8 LF	2 x 2 x 8
210/80	System 210		80	185	10			15	2 x 2 x 8 LF
210/90		90	210	10	20			2 x 2 x 8 LF	2 x 2 x 8
210/100		100	230	15	25			2 x 2 x 8 LF	2 x 2 x 10
240/20	P1 80	20	45	-----	-----	0-300	3"	-----	-----
240/30		30	70	5	7 1/2			2 x 2 x 8	2 x 2 x 8
240/40		40	95	5	7 1/2			2 x 2 x 8 LF	2 x 2 x 8
240/50		P2 160	50	115	5			10	2 x 2 x 8 LF
240/60	60		140	7 1/2	10			2 x 2 x 8 LF	2 x 2 x 8
240/70	70		160	7 1/2	15			2 x 2 x 8 LF	2 x 2 x 8
240/80	System 240		80	185	10			15	2 x 2 x 8 LF
240/90		90	210	15	20			2 x 2 x 8 LF	2 x 2 x 8
240/100		100	230	15	25			2 x 2 x 8 LF	2 x 2 x 10

### PRV

D-Duplex (D-CPS- Series-Pump Model)

For triplex System take pump P-2 twice  
T-Triplex (T-CPS- Series-Pump Model)

Sizes	Minimum Flow USGPM	Maximum Flow USGPM
2	15	208
3	35	460



# D-CPS Selection Tables (Duplex)



Based on 3450 RPM

Series 880

Unit Model Number	Pump Capacity USGPM	Head PSI	Head Feet	P1 Pump (Hp)	P2 Pump (Hp)	Header		P1 Pump Model	P2 Pump Model
						FLOW	Size		
270/20	P1 90	20	45	-----	-----	0-300	3"	-----	-----
270/30		30	70	5	7 1/2			2 x 2 x 8	2 x 2 x 8
270/40		40	95	7 1/2	10			2 x 2 x 8	2 x 2 x 8
270/50		50	115	7 1/2	10			2 x 2 x 8 LF	2 x 2 x 8
270/60	P2 180	60	140	7 1/2	10	0-500	4"	2 x 2 x 8 LF	2 x 2 x 8
270/70		70	160	10	15			2 x 2 x 8 LF	2 x 2 x 8
270/80	System 270	80	185	10	20	0-500	4"	2 x 2 x 8 LF	2 x 2 x 8
270/90		90	210	15	20			2 x 2 x 8 LF	2 x 2 x 8
270/100		100	230	15	25			2 x 2 x 8 LF	2 x 2 x 10
300/20	P1 100	20	45	-----	-----	0-300	3"	-----	-----
300/30		30	70	5	7 1/2			2 x 2 x 8	2 x 2 x 8
300/40		40	95	7 1/2	10			2 x 2 x 8	2 x 2 x 8
300/50		50	115	7 1/2	10			2 x 2 x 8	2 x 2 x 8
300/60	P2 200	60	140	7 1/2	15	0-500	4"	2 x 2 x 8 LF	2 x 2 x 8
300/70		70	160	7 1/2	15			2 x 2 x 8 LF	2 x 2 x 8
300/80	System 300	80	185	10	20	0-500	4"	2 x 2 x 8 LF	2 x 2 x 8
300/90		90	210	15	20			2 x 2 x 8 LF	2 x 2 x 8
300/100		100	230	15	30			2 x 2 x 8 LF	2 x 2 x 10
375/20	P1 125	20	45	-----	-----	0-300	3"	-----	-----
375/30		30	70	5	10			2 x 2 x 8	2 x 2 x 8
375/40		40	95	7 1/2	15			2 x 2 x 8	2 x 2 x 8
375/50		50	115	7 1/2	15			2 x 2 x 8	2 x 2 x 8
375/60	P2 250	60	140	10	15	0-500	4"	2 x 2 x 8	2 x 2 x 8
375/70		70	160	15	20			2 x 2 x 8	2 x 2 x 8
375/80	System 375	80	185	15	25	0-500	4"	2 x 2 x 8	3 x 3 x 10
375/90		90	210	15	30			2 x 2 x 8 LF	3 x 3 x 10
375/100		100	230	25	40			2 x 2 x 10	3 x 3 x 10

## PRV

D-Duplex (D-CPS- Series-Pump Model)

For triplex System take pump P-2 twice  
T-Triplex (T-CPS- Series-Pump Model)

Sizes	Minimum Flow USGPM	Maximum Flow USGPM
2	15	208
3	35	460



# FLO FAB D-CPS Selection Tables (Duplex)

Based on 3450 RPM

Series 880

Unit Model Number	Pump Capacity USGPM	Head PSI	Head Feet	P1 Pump (Hp)	P2 Pump (Hp)	Header		P1 Pump Model	P2 Pump Model	
						Flow	Size			
450/20	P1 150	20	45	-----	-----	0-300	3"	-----	-----	
450/30		30	70	5	10			2 x 2 x 8	3 x 3 x 8	
450/40		40	95	7 1/2	20			2 x 2 x 8	2 x 2 x 8	
450/50	P2 300	50	115	10	20		0-500	4"	2 x 2 x 8	2 x 2 x 8
450/60		60	140	10	20				2 x 2 x 8	3 x 3 x 8
450/70		70	160	15	30				2 x 2 x 8	3 x 3 x 10
450/80		80	185	15	30	2 x 2 x 8			3 x 3 x 10	
450/90	System 450	90	210	25	40	2 x 2 x 10	3 x 3 x 10			
450/100		100	230	25	40	2 x 2 x 10	3 x 3 x 10			

### PRV

D-Duplex (D-CPS- Series-Pump Model)

For triplex System take pump P-2 twice  
T-Triplex (T-CPS- Series-Pump Model)

Sizes	Minimum Flow USGPM	Maximum Flow USGPM
2	15	208
3	35	460

# D-CPS Selection Tables (Duplex)



Based on 1750 RPM

Series 880

Unit Model Number	Pump Capacity USGPM	Head PSI	Head Feet	P1 Pump (Hp)	P2 Pump (Hp)	Header		P1 Pump Model	P2 Pump Model	
						Flow	Size			
90/20	<b>P1 30</b>	20	45	1	1 1/2	<b>0-300</b>	<b>3"</b>	2 x 2 x 8 LF	2 x 2 x 8 LF	
90/30		30	70	5	5			2 x 2 x 10	2 x 2 x 10	
90/40		40	95	7 1/2	7 1/2			2 x 2 x 10	2 x 2 x 10	
90/50	<b>P2 60</b>	50	115	-----	-----			-----	-----	
90/60		60	140	-----	-----			-----	-----	
90/70		70	160	-----	-----			-----	-----	
90/80	<b>System 90</b>	80	185	-----	-----			-----	-----	-----
90/90		90	210	-----	-----			-----	-----	
90/100		100	230	-----	-----			-----	-----	
120/20	<b>P1 40</b>	20	45	1 1/2	2			<b>0-300</b>	<b>3"</b>	2 x 2 x 8 LF
120/30		30	70	5	5	2 x 2 x 10	2 x 2 x 10			
120/40		40	95	7 1/2	10	2 x 2 x 10	2 x 2 x 10			
120/50	<b>P2 80</b>	50	115	-----	-----	-----	-----			
120/60		60	140	-----	-----	-----	-----			
120/70		70	160	-----	-----	-----	-----			
120/80	<b>System 120</b>	80	185	-----	-----	-----	-----			-----
120/90		90	210	-----	-----	-----	-----			
120/100		100	230	-----	-----	-----	-----			
150/20	<b>P1 50</b>	20	45	1 1/2	2	<b>0-300</b>	<b>3"</b>			2 x 2 x 8 LF
150/30		30	70	5	5			2 x 2 x 10	2 x 2 x 10	
150/40		40	95	-----	-----			-----	-----	
150/50	<b>P2 100</b>	50	115	-----	-----			-----	-----	
150/60		60	140	-----	-----			-----	-----	
150/70		70	160	-----	-----			-----	-----	
150/80	<b>System 150</b>	80	185	-----	-----			-----	-----	-----
150/90		90	210	-----	-----			-----	-----	
150/100		100	230	-----	-----			-----	-----	

## PRV

D-Duplex (D-CPS- Series-Pump Model)

For triplex System take pump P-2 twice  
T-Triplex (T-CPS- Series-Pump Model)

Sizes	Minimum Flow USGPM	Maximum Flow USGPM
2	15	208
3	35	460



# FLO FAB D-CPS Selection Tables (Duplex)

Based on 1750 RPM

Series 880

Unit Model Number	Pump Capacity USGPM	Head PSI	Head Feet	P1 Pump (Hp)	P2 Pump (Hp)	Header		P1 Pump Model	P2 Pump Model		
						Flow	Size				
180/20	<b>P1 60</b>	20	45	1 1/2	3	<b>0-300</b>	<b>3"</b>	2 x 2 x 8 LF	2 x 2 x 8		
180/30		30	70	5	5			2 x 2 x 10	2 x 2 x 10		
180/40		40	95	-----	-----			-----	-----		
180/50	<b>P2 120</b>	50	115	-----	-----			-----	-----		
180/60		60	140	-----	-----			-----	-----		
180/70		70	160	-----	-----			-----	-----		
180/80	<b>System 180</b>	80	185	-----	-----			-----	-----	-----	-----
180/90		90	210	-----	-----			-----	-----	-----	
180/100		100	230	-----	-----			-----	-----	-----	
<b>Series 880 - 210 Series</b>											
210/20	<b>P1 70</b>	20	45	2	5	<b>0-300</b>	<b>3"</b>	2 x 2 x 8	3 x 3 x 8		
210/30		30	70	5	5			2 x 2 x 10	2 x 2 x 10		
210/40		40	95	15	20			3 x 3 x 12	3 x 3 x 12		
210/50	<b>P2 140</b>	50	115	-----	-----			-----	-----		
210/60		60	140	-----	-----			-----	-----		
210/70		70	160	-----	-----			-----	-----		
210/80	<b>System 210</b>	80	185	-----	-----	-----	-----	-----	-----		
210/90		90	210	-----	-----	-----	-----	-----			
210/100		100	230	-----	-----	-----	-----	-----			
<b>Series 880 - 240 Series</b>											
240/20	<b>P1 80</b>	20	45	2	5	<b>0-300</b>	<b>3"</b>	2 x 2 x 8	3 x 3 x 8		
240/30		30	70	5	7 1/2			2 x 2 x 10	3 x 3 x 10		
240/40		40	95	15	20			3 x 3 x 12	3 x 3 x 12		
240/50	<b>P2 160</b>	50	115	-----	-----			-----	-----		
240/60		60	140	-----	-----			-----	-----		
240/70		70	160	-----	-----			-----	-----		
240/80	<b>System 240</b>	80	185	-----	-----	-----	-----	-----	-----		
240/90		90	210	-----	-----	-----	-----	-----			
240/100		100	230	-----	-----	-----	-----	-----			

**PRV**

**D-Duplex (D-CPS- Series-Pump Model)**

For triplex System take pump P-2 twice  
**T-Triplex (T-CPS- Series-Pump Model)**

Sizes	Minimum Flow USGPM	Maximum Flow USGPM
2	15	208
3	35	460

# D-CPS Selection Tables (Duplex)



Based on 1750 RPM

Series 880

Unit Model Number	Pump Capacity USGPM	Head PSI	Head Feet	P1 Pump (Hp)	P2 Pump (Hp)	Header		P1 Pump Model	P2 Pump Model
						FLow	Size		
270/20	<b>P1 90</b>	20	45	2	5	<b>0-300</b>	<b>3"</b>	2 x 2 x 8	3 x 3 x 8
270/30		30	70	5	7 1/2			2 x 2 x 10	3 x 3 x 10
270/40		40	95	15	20			3 x 3 x 12	3 x 3 x 12
270/50		50	115	-----	-----			-----	-----
270/60	<b>P2 180</b>	60	140	-----	-----	<b>0-500</b>	<b>4"</b>	-----	-----
270/70		70	160	-----	-----			-----	-----
270/80	<b>System 270</b>	80	185	-----	-----			-----	-----
270/90		90	210	-----	-----			-----	-----
270/100		100	230	-----	-----			-----	-----
300/20	<b>P1 100</b>	20	45	2	5	<b>0-300</b>	<b>3"</b>	2 x 2 x 8	3 x 3 x 8
300/30		30	70	5	7 1/2			2 x 2 x 10	3 x 3 x 10
300/40		40	95	15	20			3 x 3 x 12	3 x 3 x 12
300/50		50	115	20	25			3 x 3 x 12	3 x 3 x 12
300/60	<b>P2 200</b>	60	140	-----	-----	<b>0-500</b>	<b>4"</b>	-----	-----
300/70		70	160	-----	-----			-----	-----
300/80	<b>System 300</b>	80	185	-----	-----			-----	-----
300/90		90	210	-----	-----			-----	-----
300/100		100	230	-----	-----			-----	-----
375/20	<b>P1 125</b>	20	45	3	5	<b>0-300</b>	<b>3"</b>	2 x 2 x 8	3 x 3 x 8
375/30		30	70	5	7 1/2			2 x 2 x 10	4 x 4 x 10
375/40		40	95	15	20			3 x 3 x 12	3 x 3 x 12
375/50		50	115	20	25			3 x 3 x 12	3 x 3 x 12
375/60	<b>P2 250</b>	60	140	-----	-----	<b>0-500</b>	<b>4"</b>	-----	-----
375/70		70	160	-----	-----			-----	-----
375/80	<b>System 375</b>	80	185	-----	-----			-----	-----
375/90		90	210	-----	-----			-----	-----
375/100		100	230	-----	-----			-----	-----

### PRV

D-Duplex (D-CPS- Series-Pump Model)

For triplex System take pump P-2 twice  
T-Triplex (T-CPS- Series-Pump Model)

Sizes	Minimum Flow USGPM	Maximum Flow USGPM
2	15	208
3	35	460



# FLO FAB D-CPS Selection Tables (Duplex)

Based on 1750 RPM

Series 880

Unit Model Number	Pump Capacity USGPM	Head PSI	Head Feet	P1 Pump (Hp)	P2 Pump (Hp)	Header		P1 Pump Model	P2 Pump Model	
						Flow	Size			
450/20	P1 150	20	45	5	5	0-300	3"	3 x 3 x 10	4 x 4 x 10	
450/30		30	70	7 1/2	7 1/2			3 x 3 x 10	4 x 4 x 10	
450/40		40	95	15	20			3 x 3 x 12	3 x 3 x 12	
450/50	P2 300	50	115	20	25		0-500	4"	3 x 3 x 12	4 x 4 x 12
450/60		60	140	-----	-----				-----	-----
450/70		70	160	-----	-----				-----	-----
450/80	System 450	80	185	-----	-----	-----		-----		
450/90		90	210	-----	-----	-----		-----		
450/100		100	230	-----	-----	-----		-----		

### PRV

D-Duplex (D-CPS- Series-Pump Model)

For triplex System take pump P-2 twice  
T-Triplex (T-CPS- Series-Pump Model)

Sizes	Minimum Flow USGPM	Maximum Flow USGPM
2	15	208
3	35	460



## FLO FAB ACV FEATURES

Standard Production Valves:  
Wide range of sizes 1 1/4" - 24"  
Fused epoxy coating 100% inside and out. (FDA and NSF approved, Meets AWWA standards)  
Exclusive "QUAD SEAL" retained on 3 1/2 + sides  
positive drip-tight closure  
longer life span (non-edged seat)  
Diaphragm actuated (one moving part)  
**FDA approved** diaphragm materials  
Hydraulically operated (frictionless)  
Top and bottom guided stem  
Packless construction (less maintenance)

## BASIC VALVE

Body and Cover  
Ductile Iron: ASTM A536 65-45-12  
Fused Epoxy Coated 100% inside/outside  
Seat - Stainless Steel  
AISI 316 - 1 1/4" - 8"  
Bronze ASTM B62 - 10" - 24"  
Optional: Stainless Steel  
AISI 316 - 10" - 24"  
Stem - Stainless Steel  
AISI 303 Spring  
Stainless Steel  
AISI 302 Elastomers

### Diaphragm:

Nylon reinforced BUNA-N (Nitrile)  
"Quad Seal": BUNA-N (Nitrile)  
Other materials available

## HYDRAULIC CONTROL PILOTS

Bodies: ASTM B584, Alloy C84400  
Internals: Stainless Steel - AISI 303  
Elastomers: BUNA-N (Nitrile)  
Other materials available  
MISCELLANEOUS CONTROL

## ACCESSORIES

**Bodies:** Brass ASTM B584, Alloy C84400  
**Internals:** Stainless Steel AISI 303  
**Elastomers:** (where applicable): BUNA-N (Nitrile)  
Other materials available

## ELECTRICAL

120 VAC, 60 Hz, Optional voltage available  
**Body:** Brass,  
**Optional:** Stainless Steel  
**Enclosure:** General Purpose (NEMA Type 1, 2, 3, 3S, 4, 4X)  
**Optional:** Explosion proof (NEMA Type 3, 3S, 4, 4X, 6P, 7, 9)

## CONTROL CIRCUIT STRAINER

1 1/4"-3" In-line, Flo-clean,  
**Optional:** Isolation Cocks  
4-24" External, "Y" strainer  
+ Isolation Cocks  
(unless noted on drawing)

## CONTROL TUBING/FITTINGS

Copper, seamless annealed/  
Brass flared end  
**Optional:** Stainless Steel / Stainless Steel  
OPERATING TEMPERATURES (BUNA-N)  
Water: +32 degrees to 180 degrees F  
END CONNECTIONS/MAXIMUM

## WORKING PRESSURE

**Ductile Iron:** 150# F.F. Flange:  
ANSI B16.42 / 250 PSIG 300#  
**R.F. Flange:** ANSI B16.42 / 400 PSIG  
**Threaded:** ANSI B16.4 / 400 PSIG

## RATE OF FLOW PRESSURE REDUCING

## ACV 115

Automatically reduces a higher inlet pressure to a constant lower outlet pressure regardless of changing flow rate and/or varying inlet pressure. Refer to [ACV 115-7](#) for dead-end systems and/or systems using high demand, on-off equipment.

**NOTE:**

**Adjustment range:**

**Standard:** 20-175 psig

**Optional:** 0-30 psig 100-300 psig  
(stainless steel control)

**Remote sense:** [ACV 115-1](#)

**QUICK SIZING:**

Valve size one size smaller than line.

**Points to consider:**

See Engineering Data

Pressure Reducing Sizing

Check maximum and minimum

flow Check pressure drop

pressure reducing valves

or cavitation chart

If valve size required is smaller

than line size, consider [ACV 6115](#)

Consult [FLO-FAB ACV](#) representative/factory

**VALVE FUNCTION**

Reduce higher inlet pressure to constant lower outlet pressure (adjustable)

**COMPONENTS**

1. Main Valve
2. Pressure Reducing Control
3. Fixed Orifice
4. Adj. Opening Speed (3" and Smaller)

**ACCESSORIES**

X - Isolation Cocks

Located as indicated

Y - Y-Strainer Included as marked

P - Position Indicator

FC - Flo-Clean Strainer

L - Limit Switch

ACS - Adjustable Closing Speed





## ENGINEERING DATA / SIZING

### INSTALLATION RECOMMENDATIONS AND REQUIREMENTS VERTICAL INSTALLATIONS

Avoid mounting valves 6" and larger in a vertical discharge position (valve stem horizontal or cover pointed sideways). If your installation requires this mounting position consult the factory or specify at time of order.

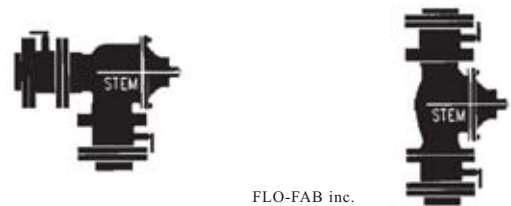

### VALVE SIZING — PRESSURE REDUCING

Selection of the correct size pressure reducing valve is a relatively simple process. Criteria for selection is minimum flow, normal flow, maximum flow and pressure drop across the valve. Following are explanations of the three types of PRV installations. These also apply to any functions combined with the reducing function, such as reducing/check and reducing/solenoid valves.



### ISOLATION SHUT-OFF VALVES

Butterfly or similar type valves should be installed in the line upstream and downstream of the automatic control valve to allow for maintenance service. Installing isolation valves will allow you to perform maintenance service without draining the system or exposing service personnel to line pressures.

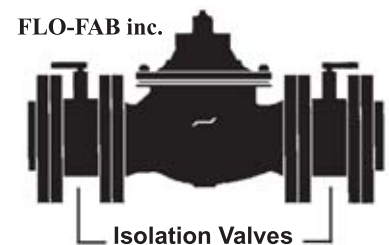

## VALVE SIZING

## VALVE SIZING

To properly size an automatic control valve you need to know the following:

Highest and Lowest inlet pressures

Outlet pressure

Maximum flow requirements

Minimum flow requirements

**Step 1:** Utilize the high flow chart and select the flow as found on the horizontal axis which corresponds with your maximum flow requirements. **Step 2:** From this point draw a vertical line until you intersect with the horizontal line corresponding with the minimum differential pressure. (Your minimum differential pressure will be the lowest inlet pressure minus the desired outlet pressure, this is also known as the delta P.) **Step 3:** From this point move right to the first valve size line. This will be the minimum valve size which should be used on intermittent flow of 25 ft./sec. If maximum flow is continuous, then do not exceed the GPM (20 FT./sec.) listed on the maximum continuous flow table. **Step 4:** Utilize the flow chart and select the maximum differential pressure as found on the vertical axis. (Your maximum differential pressure will be the highest inlet pressure minus the desired outlet pressure, this is also known as the delta P.) **Step 5:** From this point draw a horizontal line until you intersect with the line corresponding to the valve size as selected in step 3. **Step 6:** From this point draw a vertical line down to the horizontal axis. This will be the minimum flow capabilities of the valve based on these variables.

**Notes:** 1) If the minimum flow capability obtained from step 6 is above your actual minimum flow requirements, you should consider a parallel installation. Using the minimum flow capability, begin at step 1 to select the size you will need for this low-flow by-pass. 2) Use the cavitation chart and determine if the intersection of the inlet and outlet pressures falls in the shaded area. If so, you should consider a series installation. Both valves should be sized in accordance with the above steps.



## HIGH FLOW CHART (MAXIMUM INTERMITTENT FLOW)

$\Delta P$  = minimum pressure difference

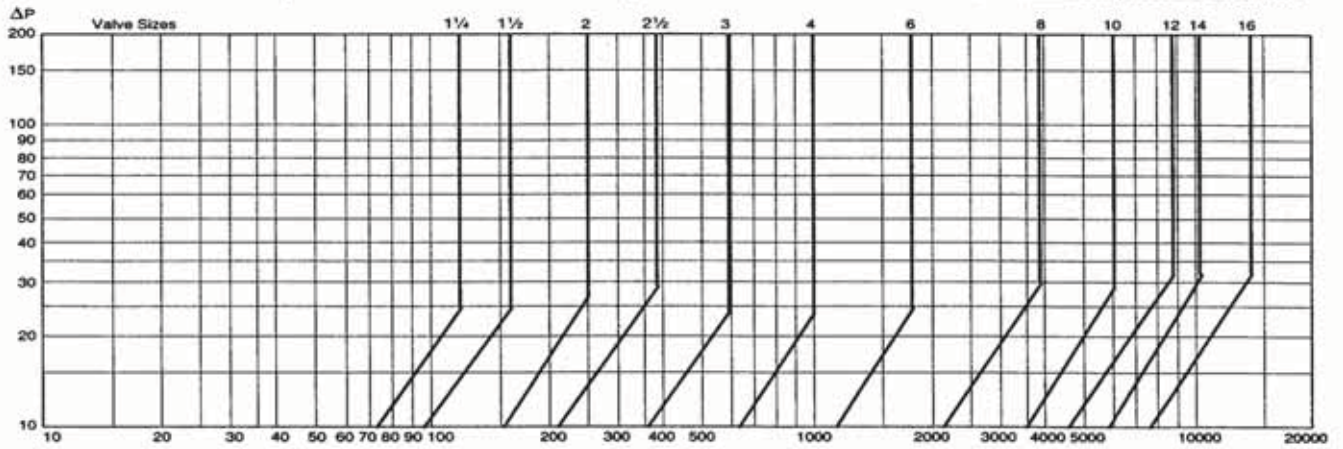

## LOW FLOW CHART (MINIMUM INTERMITTENT FLOW)

$\Delta P$  = maximum pressure difference

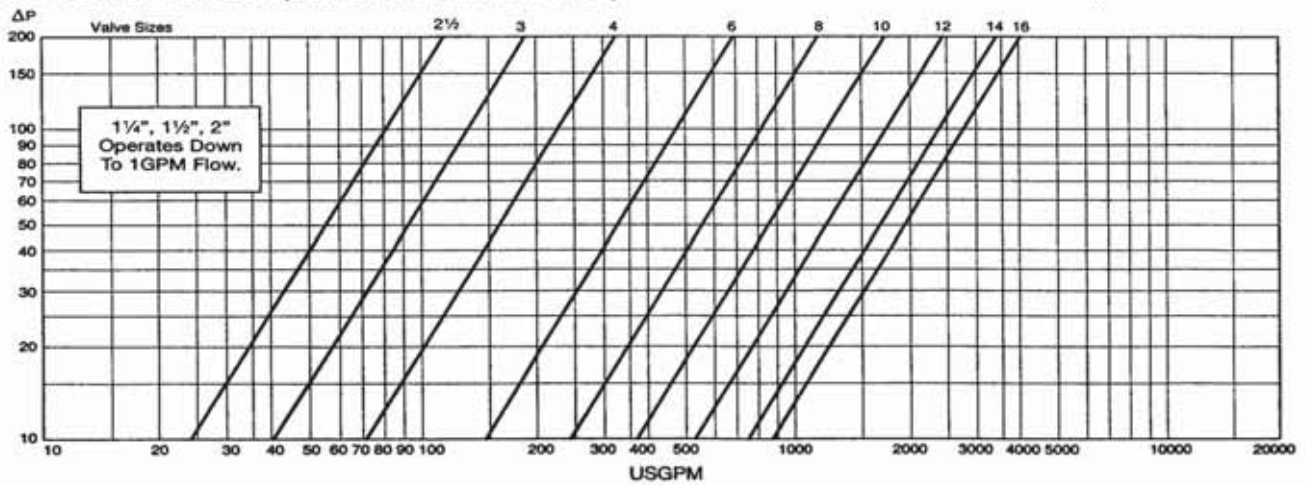

**VALVE SIZING**

**Pressure Drop Index-Pressure Reducing Valves  
Valves Sizing**

**PRESSURE DROP INDEX - PRESSURE REDUCING VALVES**

Calculate the pressure difference by subtracting the desired outlet pressure from the maximum inlet pressure. Find the number on the pressure difference line and note the outlet pressure index number. This is the lowest outlet pressure setting allowed without failing into the cavitation zone. *Design* of the **FLO-FAB Automatic Control Valve** minimizes potential valve damage that can be caused by cavitation. Avoid continued operation within the cavitation zone.

PRESSURE DIFFERENCE (PSIG)													
10	20	30	40	50	60	70	80	90	100	125	150	175	200
OUTLET PRESSURE INDEX (Lowest Outlet Setting, PSIG)													
0	0	0	3	8	14	20	25	31	37	51	65	79	93

**CAVITATION CHART**

After selecting valve size, locate inlet and outlet pressures on this chart. If the intersection point falls in the shaded area, cavitation can occur. Operation of valves continually in the cavitation zone should be avoided. Consult **FLO-FAB ACV** for alternatives.

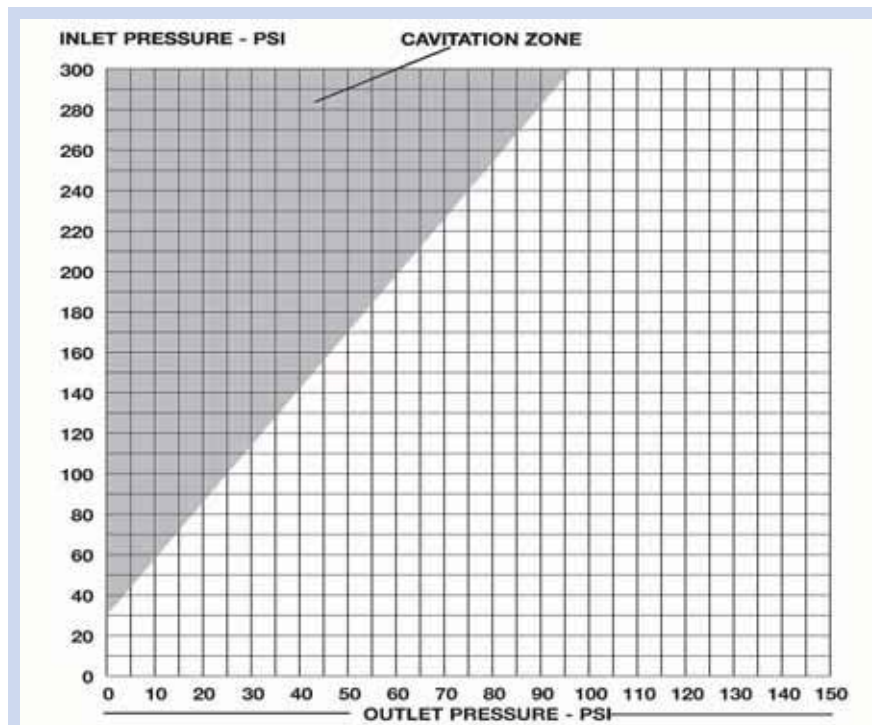



# FLO FAB inc. SUBMITTAL / SPECIFICATION

DATE	WATTS ACV REFERENCE #	FIGURE #	ASSEMBLY #	SIZE	QUANTITY
PROJECT IDENTIFICATION		DESCRIPTION			
		TECHNICAL			

COMPONENT	SPECIFICATION
<b>MAIN VALVE</b>	
BODY / COVER	<input type="checkbox"/> DUCTILE IRON - ASTM A536 65-45-12
BODY PATTERN	<input type="checkbox"/> GLOBE <input type="checkbox"/> ANGLE
END CONNECTION	<input type="checkbox"/> 150# FLANGED ANSI B16.1 (Max. W.P. 250psi) <input type="checkbox"/> THREADED ANSI B 16.4 (Max. W.P. 400 psig) <input type="checkbox"/> 300# FLANGED ANSI B16.1 (Max. W.P. 400psi)
SEAT & STEM	<input type="checkbox"/> BRASS SEAT - ASTM B584, Brass Alloy C84400 / STAINLESS STEEL STEM - AISI 303 (standard) <input type="checkbox"/> COATED BRASS SEAT - ASTM B584, Brass Alloy C84400 / COATED STAINLESS STEEL STEM - AISI 303 *Anti-scale trim XYLAN (TEFLON) coated seat and KOLENE coated stem <input type="checkbox"/> STAINLESS STEEL SEAT - AISI 303 / STAINLESS STEEL STEM - AISI 303 <input type="checkbox"/> COATED STAINLESS STEEL SEAT - AISI 303 / COATED STAINLESS STEEL STEM - AISI 303 *Anti-scale trim XYLAN (TEFLON) coated seat and KOLENE coated stem
ELASTOMERS *	<input type="checkbox"/> BUNA-N (standard) <input type="checkbox"/> BUNA-N VULCANIZED (optional) <input type="checkbox"/> VITON VULCANIZED (optional) (2 1/2" 1-PLY, 3" & LARGER 2-PLY ASTM D 2000)
<b>COATINGS</b>	
MAIN VALVE	<input type="checkbox"/> FUSED EPOXY COATING - FDA Approved Regulation 21CFR 175.300, ASTM D3451-76 (Coated 100%), NSF Approved <input type="checkbox"/> MARINE EPOXY COATING - Flexcote Abranon Coated 100%
<b>FLOW DIRECTION</b>	<input type="checkbox"/> OVER THE SEAT ("R" Flow) <input type="checkbox"/> UNDER THE SEAT
<b>CONTROL PILOTS</b>	
BODY/HOUSING	<input type="checkbox"/> STAINLESS STEEL - ASTM A743/AISI 303 <input type="checkbox"/> BRASS - ASTM B584
TRIM	<input type="checkbox"/> STAINLESS STEEL - AISI 303
ELASTOMERS (diaphragm / seat / o-rings)	<input type="checkbox"/> BUNA-N (standard) ASTM D 2000 <input type="checkbox"/> VITON (incl. when main valve elastomer is VITON)
SPRING RANGE *	<input type="checkbox"/> 20-175 PSI (standard) <input type="checkbox"/> 0-30 PSI <input type="checkbox"/> 100-300 PSI <input type="checkbox"/> SELECT TANK HEIGHT
<b>TUBING AND FITTINGS</b>	<input type="checkbox"/> TUBING: STAINLESS STEEL AISI TYPE 316 ASTM A 312 <input type="checkbox"/> COPPER / BRASS (standard) <input type="checkbox"/> FITTINGS: STAINLESS STEEL AISI TYPE 316
<b>ACCESSORIES</b>	
STRAINER	<input type="checkbox"/> FLO-CLEAN-STAINLESS STL. Housing AISI 303 Screen Type 316 <input type="checkbox"/> Y-STRAINER - STAINLESS STEEL <input type="checkbox"/> FLO-CLEAN - BRASS <input type="checkbox"/> Y-STRAINER - BRASS
POSITION INDICATOR	<input type="checkbox"/> POSITION INDICATOR - STAINLESS STEEL <input type="checkbox"/> POSITION INDICATOR - BRASS
SPEED CONTROLS	<input type="checkbox"/> ADJUSTABLE OPENING SPEED (consult schematic) <input type="checkbox"/> ADJUSTABLE CLOSING SPEED (consult schematic) <input type="checkbox"/> FIXED RESTRICTION
OTHER	<input type="checkbox"/> ISOLATION COCKS
LIMIT SWITCH	<input type="checkbox"/> SINGLE SWITCH - Single Pole Double Throw <input type="checkbox"/> GENERAL / WEATHERPROOF NEMA Type 1, 2, 3, 3R/S, 4, 12 <input type="checkbox"/> DUAL SWITCH - Single Pole Double Throw <input type="checkbox"/> EXPLOSION PROOF NEMA Type 1, 7, 9
<b>SOLENOID</b>	
VOLTAGE	<input type="checkbox"/> STANDARD 110-120 VAC 50/60 Hz <input type="checkbox"/> OPTIONAL: <input type="checkbox"/> 24 VAC <input type="checkbox"/> 240 VAC <input type="checkbox"/> 480 VAC <input type="checkbox"/> SPECIAL: <input type="checkbox"/> 6 VDC <input type="checkbox"/> 12 VDC <input type="checkbox"/> 24 VDC <input type="checkbox"/> 120 VDC <input type="checkbox"/> 240 VDC
ENCLOSURE	<input type="checkbox"/> BRASS - NEMA TYPE 1, 2, 3, 3S, 4, 4X APPLIC. (incl. gen. purpose, weatherproof & watertight enclosure) <input type="checkbox"/> MANUAL OPERATOR (STD on 3-Way & 4-Way, OPTIONAL on 2-Way) <input type="checkbox"/> BRASS - NEMA TYPE 3, 3S, 4, 4X, 6, 6P, 7, 9 APPL. (incl. weatherproof, watertight, expl. proof & ignition proof enclosure) <input type="checkbox"/> STAINLESS STL. - NEMA TYPE 3, 3S, 4, 4X, 6, 6P, 7, 9 APPLIC. MAX TEMP T2D 419°F - MANUAL OPERATOR (STD)
ACTION	<input type="checkbox"/> POWER TO SOLENOID OPENS VALVE <input type="checkbox"/> POWER TO SOLENOID CLOSES VALVE

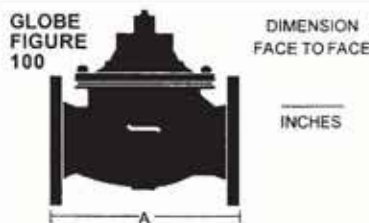

ENGINEERING APPROVAL SIGNATURE

DATE

# For Future Use

# For Future Use

# For Future Use

FF

# FLO FAB



**Manufacturer of Pumps, Tanks, Heat Exchangers & Accessories  
for HVAC Market After-Sales Parts and Services**

[www.flofab.com](http://www.flofab.com)

FLO-FAB INC  
LAKE WORTH,  
FLORIDA, USA

SEPTEMBER 2009