



# Automatic Air Vents

## Series MV

Operation, Maintenance  
& Installation Manual



[www.flofab.com](http://www.flofab.com)  
001-iom-2017-mv

# AUTOMATIC AIR VENT

**FEATURES:**

- Rugged Semi-Steel Body and Cover
- Stainless Steel Float and Trim
- Spherical Float for Strength
- Special Design Eliminates Blow-By
- Tapped to take safety drain line
- Two sizes equip all riser systems



The FLO FAS features a Stainless Steel spherical float design. Air in piping system is vented through discharge valve which is normally open. Rising water activates float to close valve. Valve outlet is tapped to take safety drain line. Simplicity of design in the FLO FAS assures long-lasting efficiency. Stainless steel float and valve mechanism involve no wearing parts, no intricate function. Precision formed body of semisteel custom-fits float and valve... protectively houses their operation under the most rugged conditions. See specifications at bottom.

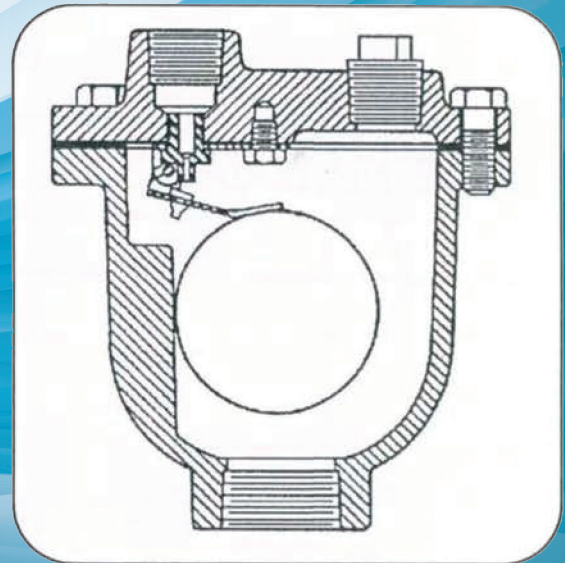

**SPECIFICATION:**

✓	FLO FAB MODEL NUMBER	INLET SIZE	OUTLET SIZE	MAX PRESSURE	MAX TEMP	VALVE ORIFICE	OVERALL HT	OVERALL WIDTH	OVERALL LENGTH
	<b>MV15</b>	1/2"	3/8"	150 PSI (1034 KPA)	345 Deg F (184 Deg C)	1/16"	5 1/4"	4 1/4"	4 3/4"
	<b>MV15</b>	3/4"	3/8"			1/16"	5 1/4"	4 1/4"	4 3/4"
	<b>MV30</b>	1/2"	1/2"	300 PSI (2068 KPA)	425 Deg F (226 Deg C)	1/16"	6"	5 1/8"	5 1/8"
	<b>MV30</b>	3/4"	1/2"			1/16"	6"	5 1/8"	5 1/8"

Dimensions are subject to change without notice.

# AIR RELEASE VALVE INSTRUCTION SHEET

- The FLO FAB air release valve is fully automatic and requires no regular maintenance.
- The purpose of the FLO FAB air release valve is to release air which accumulates in the pipeline during operation of the system.

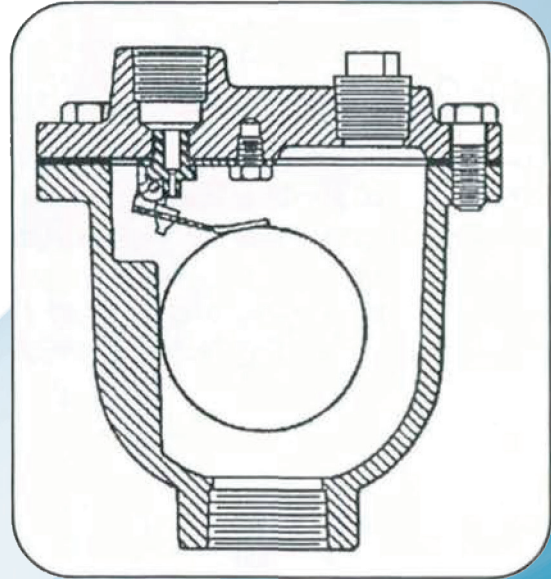

## INSTALLATION:

FLO FAB air release valves should be installed at high points on the piping system and in conjunction with the air separators. Adequate venting and drainage should be provided. A full ported shut off valve should be installed below each in case servicing is necessary.

## OPERATION:

As the piping systems is being filled, air is vented through a small opening in the valve. When fluid enters the valve, the float raises and shuts off the opening, thereby preventing any leakage. Later, as air enters the valve, the float will drop, allowing the venting to open once again . The cycle continues as necessary throughout the course of the pumping cycle.

## MAINTENANCE:

No regular maintenance is necessary, however, periodic inspection for leakage and malfunction should be performed. If the valve is not functioning properly, the valve should be removed and inspected for wear or damage from foreign particles.

We are proud supplier for the following completed and on going projects :

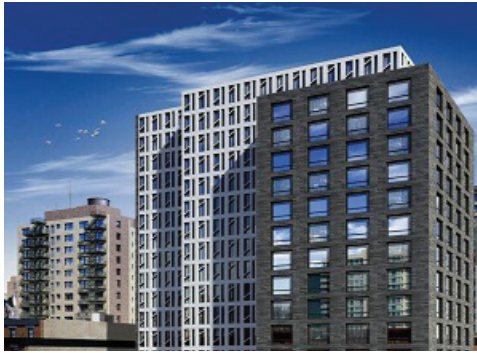

**444 10th Avenue North**  
New York, NY 10001.  
USA



**Edgemere**  
1502 Lakeshore Road E.,  
Oakville, Ontario, Canada

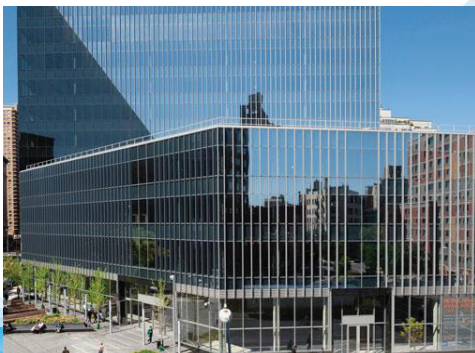

**51 Astor**  
25 Cooper St, New York,  
NY 10034, United States



**Tricentris, Lachute**  
Félix-Touchette Road,  
Lachute, Quebec, Canada

## Sales and Service:

Quebec, Canada  
Tel. : (450) 621-2995  
Fax : (450) 621-4995

Lake Worth  
Florida, USA  
33467-5749

Toronto, Canada  
Tel. : +1 (647) 544-2995

[www.flofab.com](http://www.flofab.com)

SERVICE 24/7 : [parts@flofab.com](mailto:parts@flofab.com)

