

# Heat Exchangers

**Series FFWP  
& FFWPDW**

**Operation, Maintenance  
& Installation Manual**

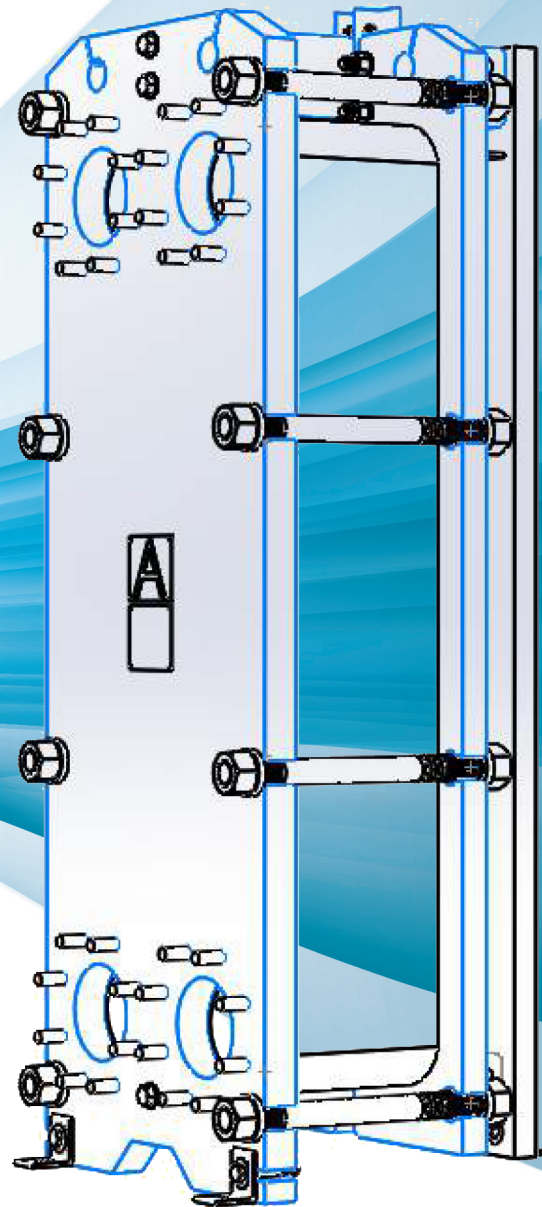

[www.flofab.com](http://www.flofab.com)

001-cat-2017-heiom

Go to [www.flofab.com](http://www.flofab.com) in Our Products Section to see the Master Spec - <http://www.arcomnet.com/masterspec/>

# TABLE OF CONTENTS

<b>1.0 PLATE HEAT EXCHANGERS - WORKING PRINCIPLE</b>	<b>2</b>
<b>2.0 PARTS &amp; THEIR FUNCTION</b>	
<b>2.1 FRAMES</b>	<b>2</b>
<b>2.2 PLATES</b>	<b>3</b>
<b>2.3 GASKETS</b>	<b>4</b>
<b>2.4 FLOW &amp; PLATE ARRANGEMENT</b>	<b>5-6</b>
<b>3.0 INSTALLATION</b>	
<b>3.1 LIFTING</b>	<b>7</b>
<b>3.2 INSTALLATION</b>	<b>7-8</b>
<b>3.3 PIPING</b>	<b>8-9</b>
<b>3.4 STORAGE</b>	<b>10</b>
<b>4.0 OPERATION</b>	
<b>4.1 GENERAL</b>	<b>11</b>
<b>4.2 STARTING UP</b>	<b>11-12</b>
<b>4.3 SHUTTING DOWN</b>	<b>13-14</b>
<b>5.0 MAINTENANCE</b>	
<b>5.1 OPENING THE HEAT EXCHANGER</b>	<b>15-16</b>
<b>5.2 CLOSING THE HEAT EXCHANGER</b>	<b>17-18</b>
<b>5.3 GASKETING</b>	<b>19-20</b>
<b>6.0 PROBLEM SOLVING</b>	
<b>7.0 CLEANING</b>	
<b>7.1 FOULING TYPES</b>	<b>22-23</b>
<b>7.2 CLEANING PHYSICALLY</b>	<b>23-24</b>
<b>7.3 CLEANING IN PLACE</b>	<b>24-25</b>
<b>8.0 REPLACEMENT PARTS</b>	<b>26</b>

# HISTORY

Flo Fab was established in 1981 by Denis Gauvreau who created and developed the products line and constantly being perfected by Marc Gauvreau, as well as by a team of professional engineers and designers. It's a combination of existing designs from several renowned products and the innovative ideas of a new generation professionals.

Through the years, Flo Fab has acquired several companies and service entities including : AQUA-PROFAB (ASME Tanks manufacturer), MÉNARD, LÉONARD ÉLECTRIQUE, PMA. , Furthermore Flo Fab purchased equipment, fabrication designs and patterns from IDEALCO, a manufacturer of shell and tube type heat exchangers.

The after sales services, sales, engineering, R&D, production, quality control, accounting and administration departments of all the above companies share the same location.

In December 2014, Marc Gauvreau, son of the founder, acquired all shares of The company. Flo Fab and is constantly investing in new state of the art innovations new product like the XRI series and Prefab Skid for Hydronic Heating 8 cooling system, pumping systems. This has allowed Flo Fab to retain competent and experienced staff of professionals with varied and specialized abilities that constantly work on improving our existing products and add new engineered solutions that exceeding customer's expectations . Flo Fab has grown quite rapidly and now proudly offers of a wide range of products available directly from one manufacturer. This includes pumps & pump packages, tanks, heat exchangers & hydronic accessories. This allows each project stakeholders to enjoy economical savings, peace of mind, best value for their investment and optimized total cost of ownership.



Go to [www.flofab.com](http://www.flofab.com) in Our Products Section to see the Master Spec - <http://www.arcomnet.com/masterspec/>

## 1.0 Plate Heat Exchangers - Working Principle

The Flo Fab FFWP gasketed plate heat exchanger consists of formed chevron plates of corrosion resistant metals. Every other plate is reversed so the ridges of the herringbone pattern intersect one another on adjacent plates forming a lattice of contact points. The plates have an elastomer gasket that is contained in a formed groove to seal the fluid between the plates. The plates with gaskets are then installed in a pressure retaining frame and compressed to form two separate systems of channels for two media to flow in a countercurrent direction.

The lattice structure causes vigorous turbulence, thus, ensuring maximum heat transfer.

## 2.0 Parts & Their Function

### 2.1 Frames

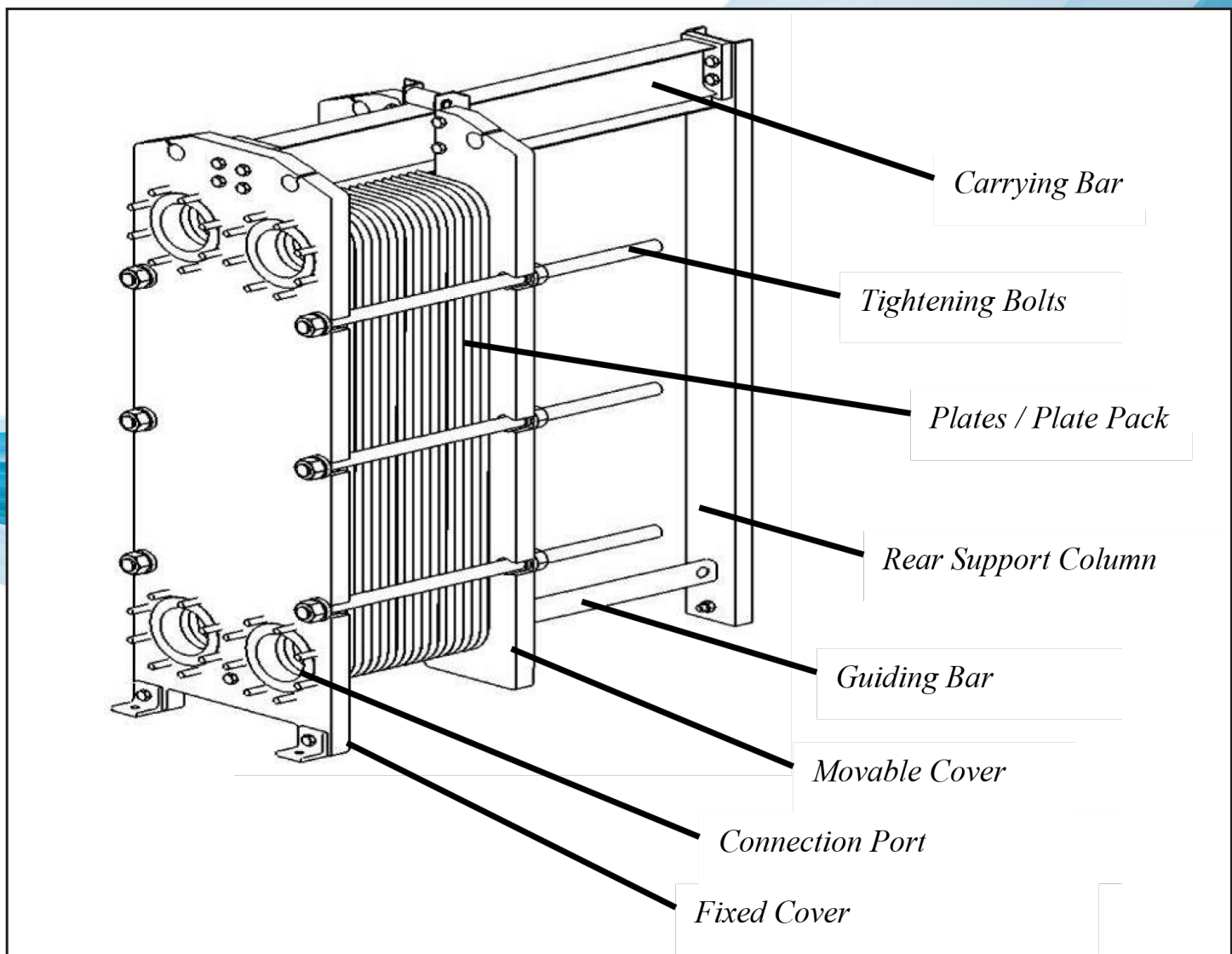

The frame is made up of thick steel pressure retaining parts, the fixed cover and the movable cover, that when pulled together with the tightening bolts form the pressure retaining structure for the plates / plate pack.

The carrying bar and guide bar act as a carrier and guide to both the plates and the movable cover.



## 2.2 Plates

The heat exchanger plates, which make up the heat transfer surface, are clamped between two plates of steel with the use of the tightening bolts. The heat exchanger construction allows a plate heat exchanger to be easily opened for inspection and cleaning.

The plate pattern is corrugated and varies depending on the application and the fluids being put through the heat exchanger. As the plate's corrugation depth gets smaller the thickness of the plate can be less.

Each heat exchanger plate is formed by pressing in one piece (no seams or welds). Most plates have four holes punched, one in each corner. The last plate in a single pass unit has no holes so the fluid flow is reversed or turned. Multiple pass heat exchangers have turning plates with only two holes for redirecting the fluid flow.

Flo Fab heat exchanger plates are made with two different pressing patterns – one is characterized by an obtuse angle giving a high theta plate, the other with an acute angle giving a low-theta plate.

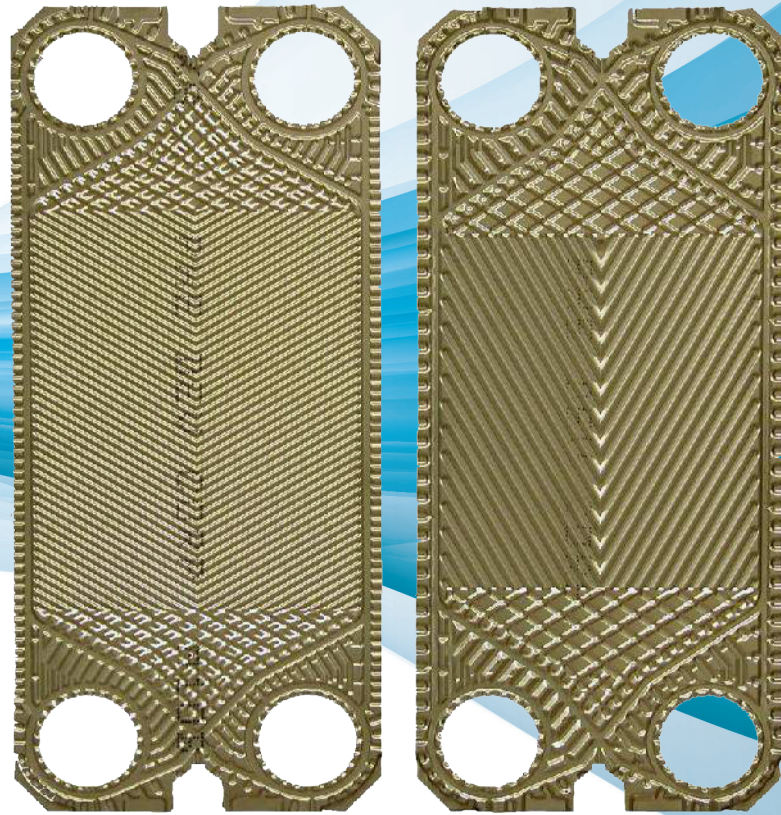

**HIGH-THETA PLATE**

**LOW-THETA PLATE**

Between two adjacent plates a flow channel is formed with the aid of the gasket. The liquid flows straight up or down or in parallel flow. No liquid flows between the plates adjacent to the fixed cover and the moveable cover plate.

The corrugated chevron pattern is alternated from plate to plate. This gives the plates contact points for pressure resistance and also forms a liquid stream that is subject to extensive turbulence resulting in a high heat transfer coefficient, as well as reducing the risk of deposits on the heat transfer surface.

## 2.3 Gaskets

Each plate has a gasket that produces a sealing and channel system through the entire plate pack in which the two heat exchanging media flow in a counter-current direction.

The circular portion of the gasket stops the fluid from going across the heat transfer plate and sends it to the next open channel. The remaining portion or field gasket, directs the opposing fluid across the heat transfer surface.

The gasket can be mechanically clipped to the plate with the glue free "U" shaped clip or glued in place.

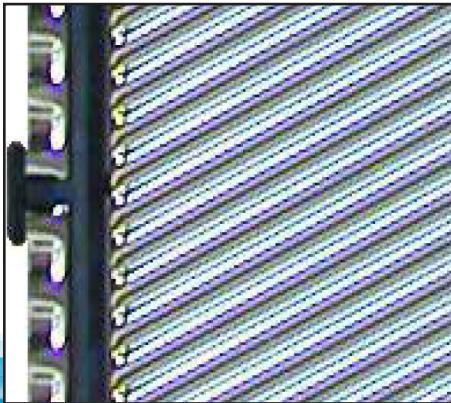

The gasket is double around the ports to prevent intermixing of the two fluids. In the event of gasket failure, any leakage is vented external to the equipment.

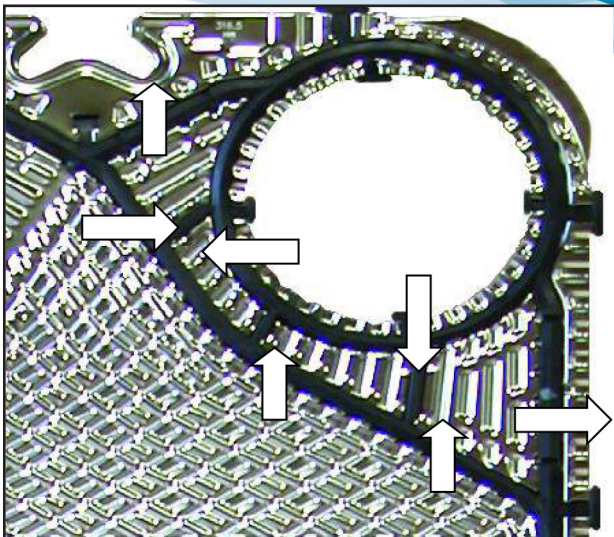

Exit to atmosphere



## 2.4 Flow and Plate Arrangement

The heat transfer plates with gaskets are arranged in an alternating pattern of left hand flow and right hand flow to direct the fluids in an opposing direction within the in the heat exchanger. The completed assembly of all the plates and gaskets is called the "plate pack".

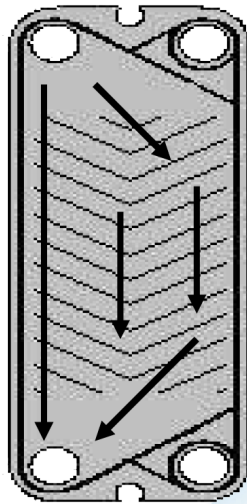

**"A"**  
Left Hand Flow

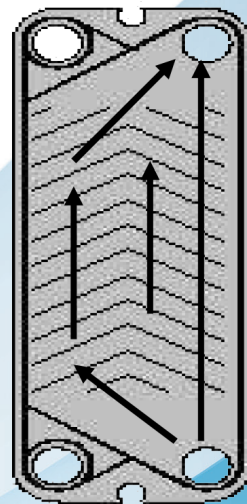

**"B"**  
Right Hand Flow

### NOTICE!

To guarantee the proper assembly and sequence of the plate pack, the plates must be arranged in an alternating "A" and "B" style. Consequently, the corrugated chevron pattern on the plates must Alternate between pointing up and down!

Ring Gaskets.  
(Four corners)

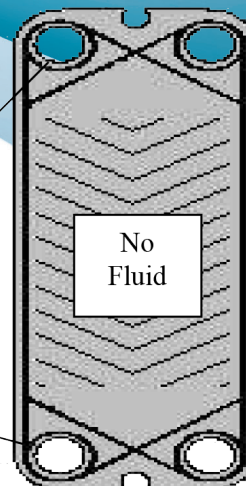

Depending on the number of passes a plate heat exchanger may have, the connection location may vary. Since all of the heat exchangers are parallel or same side flow, all connections for one fluid will be on the right side and the opposing fluid on the left side.

The connection location and typical arrangement are as follows;

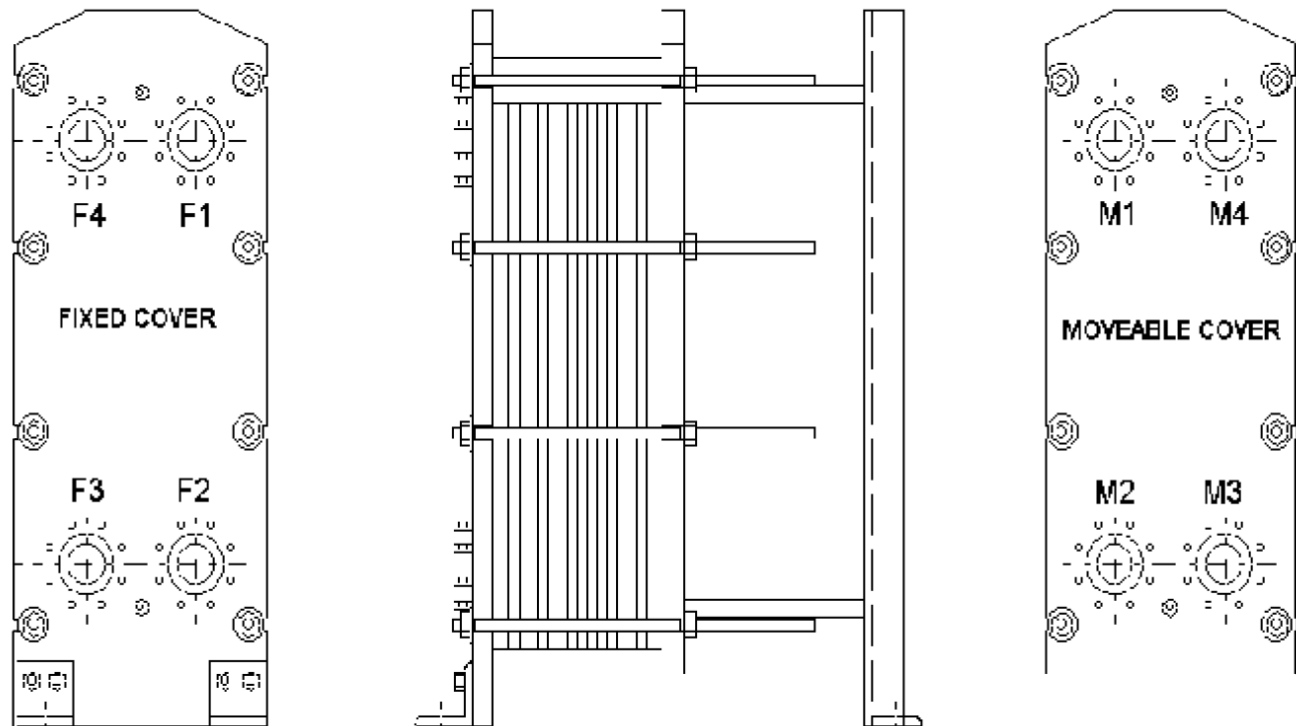

Number of Passes	Fluid 1 Inlet	Fluid 1 Outlet	Fluid 2 Inlet	Fluid 2 Outlet
1	F1	F2	F3	F4
2,4,6,,,,,,	F2	M2	M3	F3
3,5,7,,,,,,	F2	M1	M4	F3

An assembled unit must always have the plate chevron pattern rotated 180 degrees from plate to plate.

The first plate shall be double gasketed as shown on page 5.

Units with more than one pass will require special circular ring gaskets to seal the Back side of the last thermal transfer plate to the inside of the moveable cover connections.

## 3.0 Installation

### 3.1 Lifting

The plate heat exchanger shall be lifted by the four lifting holes that are provided ( two in the fixed cover and two in the moveable ).

### NOTICE!

Do not lift the heat exchanger by its connections or rear support column!

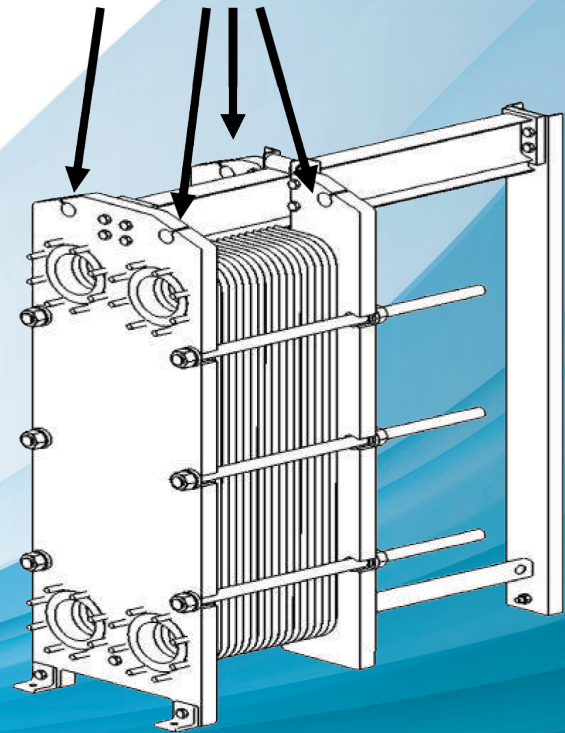

### 3.2 Installation

The plate heat exchanger is to be mounted vertically on the floor with a level foundation and be strong enough so no settling occurs that can cause a loading strain on the connections.

The heat exchanger must be installed with clearance on both sides for maintenance. Under special circumstances these dimensions may be reduced but the servicing of the heat exchanger may be compromised.

The foundation for the heat exchanger must be level and firm enough that no settling occurs which could put forces and strain on the piping connected to it.

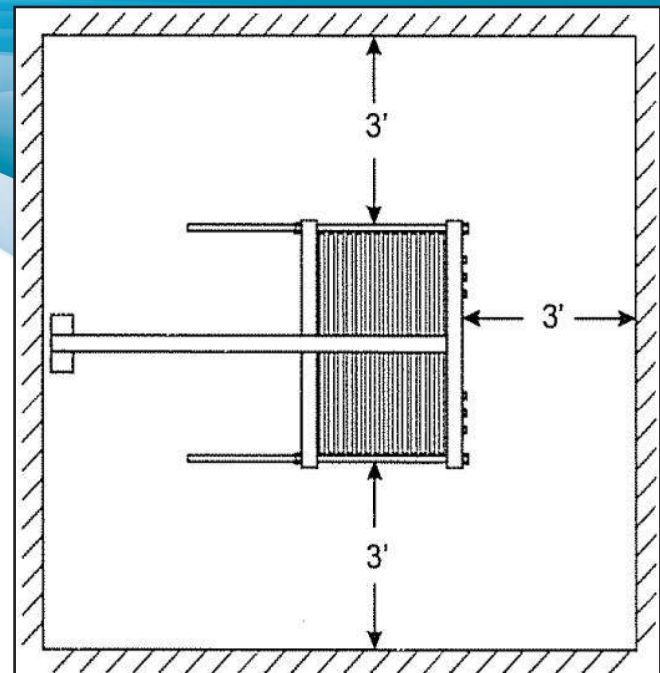



When the plate heat exchanger is installed in a situation having zero tolerance for process fluids being on the floor, a liquid retaining drip pan with a volume capacity equal to the heat exchanger shall be mounted under the plate pack to catch and control any leaking fluids.

All connections to the heat exchanger must be provided with shut-off valves (F2,F3,M2,M3). The upper connections must be provided with venting devices at their highest points. The hot side regulating valve must be installed in the feed pipe between the pump and the shut off valve.

To prevent water hammer in the heat exchanger, quick action valves should not be used.

Provide safety relief valves where the maximum discharge pressure of the pump can exceed the design pressure of the heat exchanger.

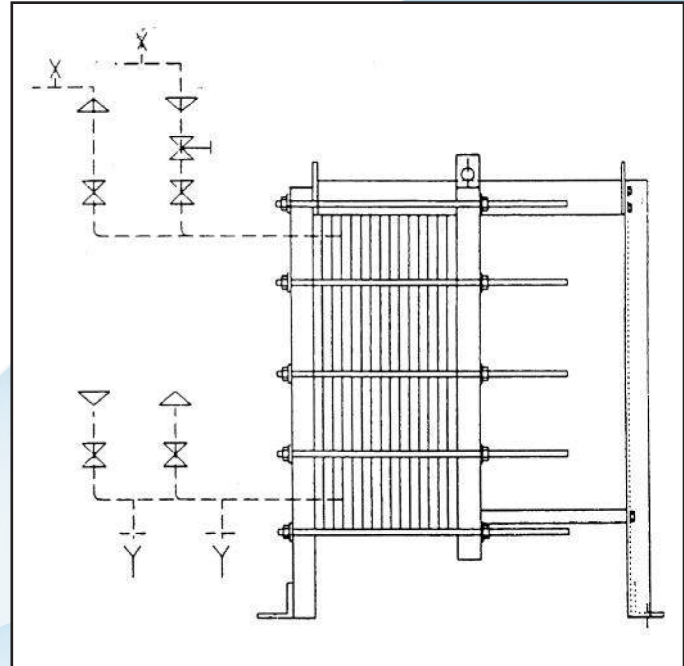

Pumps should have throttling valves and vibration dampers shall be used on positive displacement pumps and especially reciprocating pumps.

For care free and dependable operation of the heat exchanger, avoid sudden pressure and/or temperature surges.

## NOTICE!

Sudden fluctuations in temperature and/or pressure can cause temporary leakage in a plate heat exchanger.

Before installing the piping to the heat exchanger, inspect all the ports for foreign debris that could become lodged during operation.

### 3.2 Piping

The piping connected to the heat exchanger shall be designed and built so that its thermal expansion and weight do not apply any force to the heat exchanger's nozzle causing premature failure.

Any forces or moments applied to the connections of the heat exchanger must be approved by Flo Fab

The following shows typical connections available on the heat exchangers;

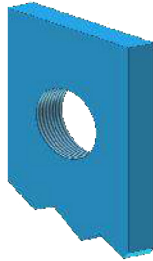

**Threaded - NPT  
Carbon Steel**

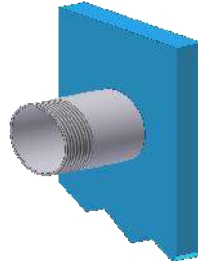

**Threaded - NPT  
Alloy Nozzle**

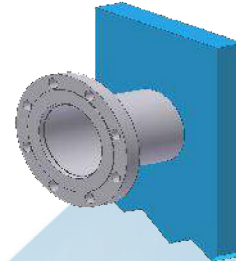

**Flanged-  
ANSI**



**Studded - ANSI  
Carbon Steel**

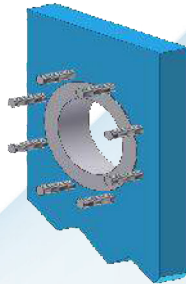

**Studded - ANSI  
Alloy Lining**

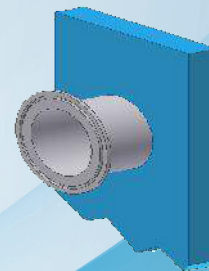

**Ferrule-  
Quick Disconnect**

## NOTICE!

When piping units with Threaded-NPT Alloy Nozzles, the nozzles must be held in place by a wrench to avoid damage.

When the heat exchanger has connections on the moveable cover there are special piping

- The moveable cover is not fixed so it's nozzles can withstand less loading than the nozzles on the fixed cover.
- The unit may be subject to re-tightening during service, therefore when attaching piping to the moveable cover you must allow for this difference (approximately plus or minus 1% of final tightening dimension).
- The moveable cover goes backward for servicing. Use elbowed spool pieces for easy removal.

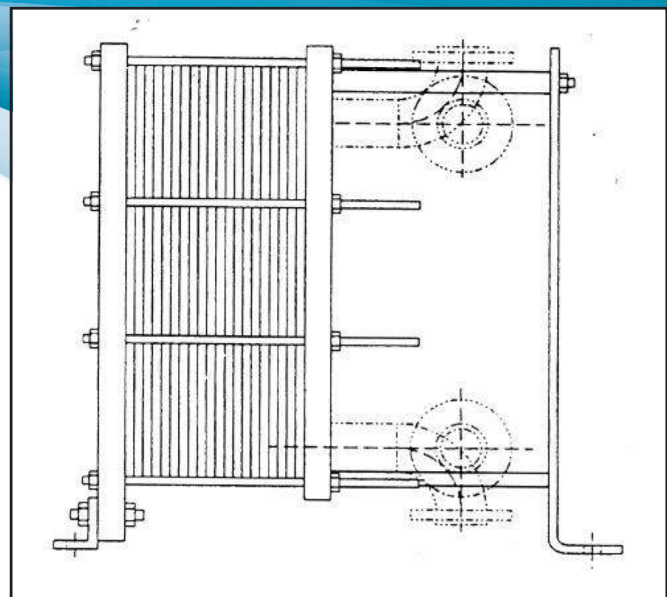

### 3.4 Storage

If the heat exchanger is to be placed in long term storage, the following steps should be taken;

- Store heat exchanger in a closed room at 60 to 70 degrees F
- The heat exchanger tightening bolts and plate pack shall be completely un-tightened and stress free.
- The heat exchanger should be totally covered in black plastic to prevent light and dirt from adversely affecting the gaskets.
- Avoid heat, ultraviolet and welding light.
- Apply a rust preventative to all machined carbon steel parts including bolts and flanged faces.



## 4.0 Operation

### 4.1 General

Check that the operating pressures and temperatures do not exceed those stated on the heat exchanger nameplate.

Check that all tightening bolts are properly tightened.

Be certain the plate pack tightening dimension ( "T" ) matches the nameplate or assembly drawing before pressurizing the heat exchanger.

### NOTICE!

Prior to starting the unit, inspect the piping to the heat exchanger to insure that it is free from debris. Sand or particles will plug the heat exchanger during operation.

### 4.2 Starting Up

The lower pressure and temperature operating fluid side should always be introduced first to the heat exchanger during start up;

- 1) Totally shut off the valve located between the pump and the heat exchanger inlet.
- 2) Open fully the valve located at the outlet connection.
- 3) Open the vent valve.
- 4) Start the pump.
- 5) Open the valve between the pump and the inlet to the heat exchanger very slowly!
- 6) When all the air is bled from the system close the vent valve
- 7) Repeat steps 1 through 6 for the other fluid side.

When using steam in the heat exchanger there are special considerations to follow;

- Never have the steam side on with the liquid / cold side turned off.
- Steam inlet shall always be a top connection with an outlet condensate drain at the bottom.
- Steam must always be turned on second and shut off first
- The steam valves must open gradually to avoid damaging the plates.
- Bring steam side up to design conditions slowly by controlled throttling of the cold side fluid to prevent shocking the heat exchanger.

### 4.3 Shutting Down

Shutting down should take place slowly;

- 1) Slowly close the valve between the pump and the inlet connection of the heat heat exchanger for the fluid at the higher pressure and temperature.
- 2) Turn pump off.
- 3) Close the valve on the outlet side of the heat exchanger.
- 4) Repeat this procedure for the other fluid side.

If the heat exchanger is to be out of service for an extended period of time or requires maintenance, vent and drain the heat exchanger. Prior to storage rinse and clean the plates to remove any foreign substance.

Storage procedures on page 10 are recommended for any heat exchanger that will be out of service for a month or longer. This is especially recommended when there is a risk of freezing or if the media in the heat exchanger is corrosive.

## 5.0 Maintenance

### 5.1 Opening the Heat Exchanger

The heat exchanger must have been shut down in accordance with the previous section ( 4.3). Allow the heat exchanger to stand and cool to room temperature, preferably overnight and drain in accordance with the previous section.

- 1) If the heat exchanger has connections on the moveable cover, the piping must be removed to allow the cover to move backward for opening.
- 2) The upper carrying bar should be inspected and wiped clean.
- 3) Clean the threads of the tightening bolts with a wire brush and then apply a thin layer of molybdenum disulphide or other equivalent grease for lubrication.
- 3) Remove the safety shield from the unit.
- 4) To keep the plates in the proper order when removing them, they can either be sequentially marked as they are removed or a diagonal line can be drawn across the plate pack to record each plate's position.
- 5) Record the actual plate tightening dimension "T", the distance between the inside edges of the fixed and moveable covers.
- 6) If the tightening bolt assemblies for the heat exchanger have a locking washer under the nut at the moveable cover, all tightening can be done from the nuts located at the fixed cover.

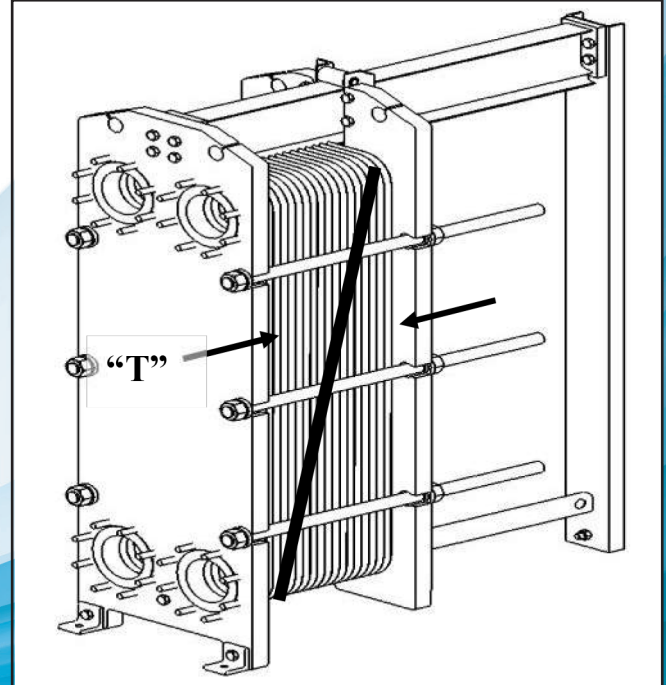

### NOTICE!

The tightening dimension "T" is crucial for proper tightening and sealing of the Heat exchanger, be certain it is recorded correctly!



7) Open the heat exchanger by diagonally loosening tightening bolt pairs. Keep the fixed and moveable cover parallel during opening by loosening each nut in  $\frac{1}{4}$ " to  $\frac{1}{2}$ " increments. This will avoid damage to the heat transfer plates.

8) After all the tension is removed from the tightening bolts and they are loose, they can be taken out and the moveable cover slid or rolled backward to allow access to the plates for inspection and/ or removal.

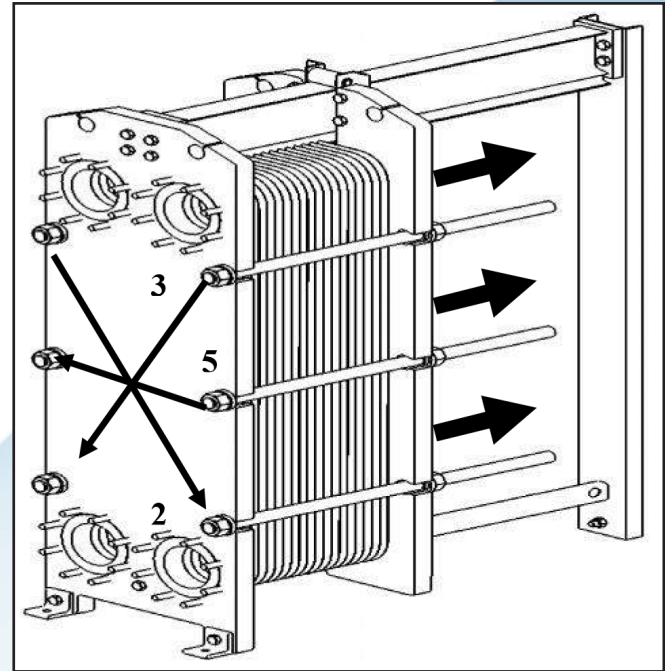

## NOTICE!

Use gloves when removing plates from the heat exchanger as the outer edges can be very sharp!

The heat transfer plates are now removed as follows;

- Move the bottom end of the heat transfer plate diagonally back until it's lower end is clear of the lower guide bar.
- Rotate the bottom end of the plate outward until it's side is clear of the lower guide bar and now the plate is removed by moving it slightly downward to free it from the upper carrying bar
- Either remove or add plates with this method.

If two or more plates are stuck together, they must be separated carefully, so that the gaskets are kept with the correct plate.

The heat transfer plates support each other in pairs. If a plate has been so damaged that it must be taken out and cannot be repaired or replaced with an identical one, it's adjacent plate must also be removed.

## 5.2 Closing the Heat Exchanger

Prior to installing the heat transfer plates consult the plate arrangement drawing to insure the proper sequencing of the plates.

Typical single pass plate arrangement;

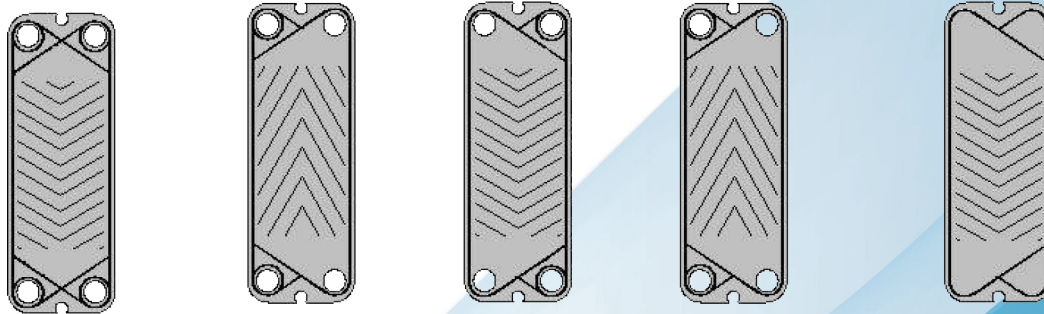

**Starter Plate    Low Plate    High Plate    Low Plate    End Plate**

Typical multi pass plate arrangement;

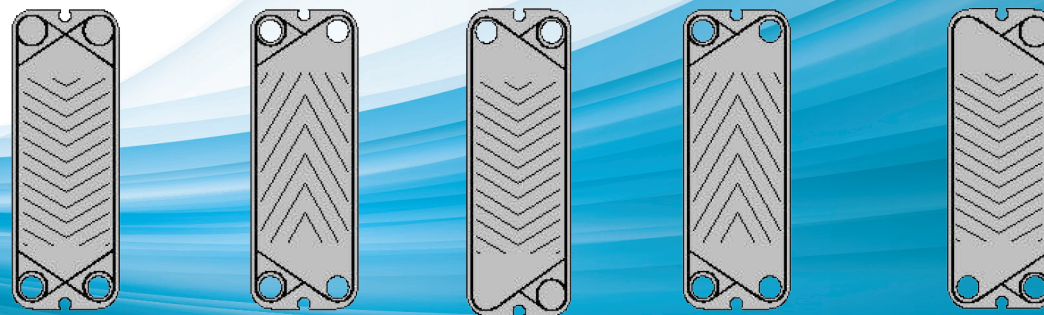

**Starter Plate    Low Plate    Turning Plate    Low Plate    End Plate**

- 1) Check that all sealing surfaces are clean.
- 2) Check that the sealing surface at the connections are smooth and free from burrs or debris.
- 3) Install the plates one at a time with the gasket facing the fixed cover and push them forward until they stop.

### NOTICE!

Plates should always be installed with the chevron pattern alternating between pointing down and up.

- 4) Prior to pushing the plates forward examine them to make certain the gasket is in it's correct position and that it is clean. Wipe the gasket surface with a clean cloth if necessary to remove any foreign material.
- 5) The upper carrying bar and lower guide bar should be cleaned and lubricated.

6) If the plates were diagonally marked prior to their removal, verify the plates are in the proper order before tightening.

6) If the plates are assembled correctly the plate edges will form a honeycomb pattern and If glue-less gaskets are used the external tabs will be aligned.

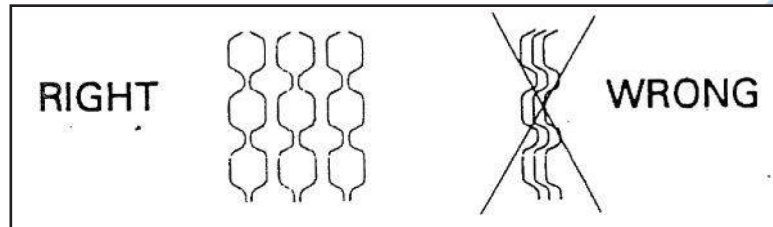

8) Set the tightening bolts into position on the frame and wire brush them and apply a thin layer of grease.

7) Begin tightening the heat exchanger by alternating between diagonally opposite bolt pairs contrary to the opening procedure. During the tightening process, the distance between the fixed and moveable cover measured at all points shall differ more than  $\frac{1}{4}$ " to  $\frac{1}{2}$ ".

8) During tightening check the "T" dimension at four points nearest the bolts being used to close heat exchanger.

9) Tighten the heat exchanger until the "T" dimension is equal +/- 1% of the dimension specified on the drawing or nameplate or a new dimension based on the addition or removal of plates.

10) All tightening bolts must be under tension.

11) After fully tightening the heat exchanger, the difference between the "T" dimension at any adjacent bolt shall not exceed  $\frac{1}{16}$ ". The "T" dimension must not differ by more than 1% for all tightening bolts.

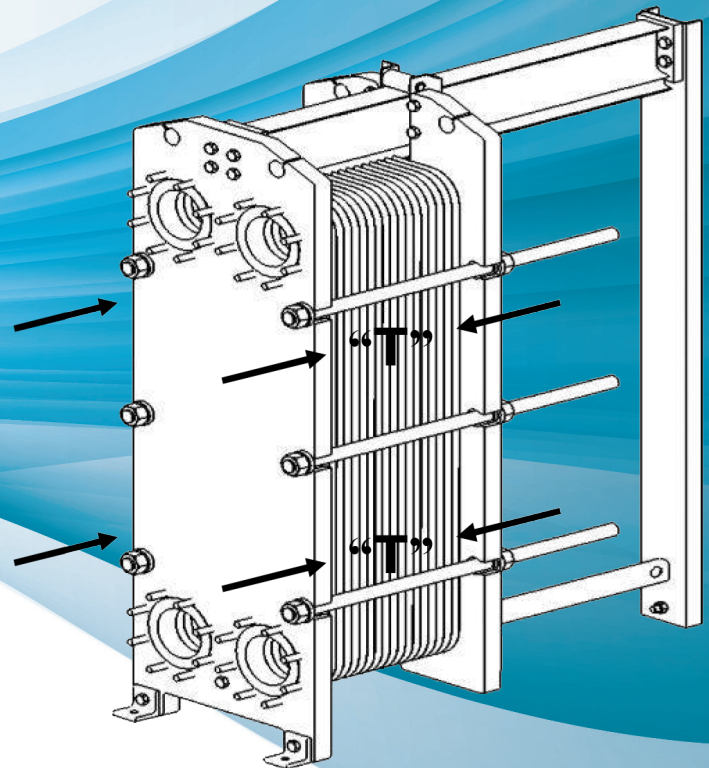



### 5.3 Gasketing

**5.3.1** Glueless or glue free gaskets are provided for most models. These gaskets are replaced as follows;

- 1) Peel the old gasket off of the plate and make certain all parts of it are totally removed.
- 2) Wipe the gasket groove clean making sure no foreign materials remain that could cause the gasket to seat improperly.
- 3) Secure the new gasket to the plate by slipping the gasket tabs under the edge of the plate. Note that there are two tabs at each attachment location at regular intervals around the circumference of the plate.
- 4) Prior to closing the heat exchanger make sure all the gasket tabs are in the proper position.
- 5) The plate heat exchanger is then closed and tightened with the gaskets providing a tight seal.

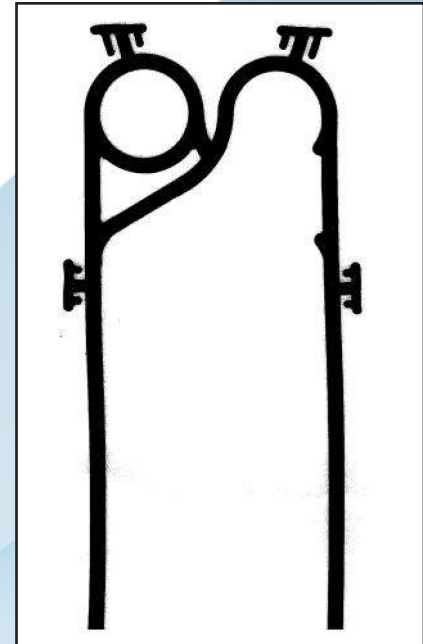

#### **NOTICE!**

Always confirm that any cleaning fluid to be used is compatible with the plates and gaskets in the heat exchanger. Consult the local cleaning solution supplier if necessary.

#### **NOTICE!**

The adhesive must be determined to be compatible with the plate and gasket material and the heat exchanger service. Consult supplier if necessary to confirm.

4) The amount of adhesive required can be estimate as follows;

Models:	WP10 – WP41	WP45 – WP61	WP80 – WP140
Plate Size:	up to 3 sq. ft.	up to 7 sq.ft	up to 20 sq.ft.
Ounces/plate:	0.50	1.00	1.50

5) Visually inspect the gasket groove before applying the adhesive to make certain it is clean and dry.

6) Rough the flat side of the gasket that will be bonded to the plate using sand paper or an emery cloth.

7) Use a short hard brush to apply a thin layer of adhesive in the gasket groove.

8) After the glue becomes tacky, which could take 5 to 10 minutes, carefully line the gasket up with the groove and press it in.

9) A gasket's dimensions may change slightly after forming. If gaskets are too short they must be stretched by pulling prior to installation and gaskets that are long should have the short ends installed first and then press the gaskets in moving toward the middle of the plate.

10) Carefully stack the plates and put weight on top and allow the adhesive to dry per the manufacturer's guideline.

5.3.3 Endplate gaskets that seal the first heat transfer plate against the fixed cover and in units being multipass or having connections on the moveable cover sealing to the last heat exchanger plates require special consideration.

The gasketing on the first or starter heat transfer plate is made by cutting two standard gaskets and attaching them to the plate as shown;

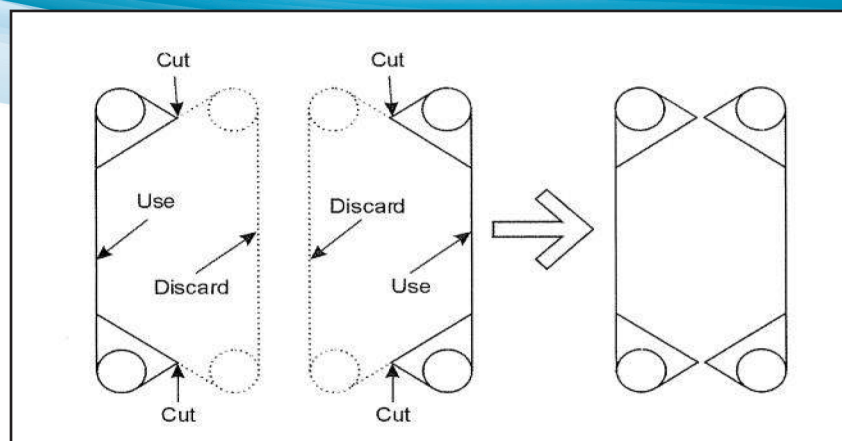

## NOTICE!

When a heat exchanger has connections located on the moveable cover, special ring gaskets must be installed on the moveable cover that will seal against the back of the last heat transfer plate.

## 6.0 Problem Solving

The following is a guide for trouble shooting a heat exchanger that may not be performing as expected. If more assistance is required please contact Graham personnel.

SYMPTOM : Fluid is leaking between two heat transfer plates and to the outside.

CAUSE: A gasket is loose or damaged.

SOLUTION: Mark or record which plate is leaking and open the heat exchanger in accordance With section 5.1. Examine the plate in question to see if the gasket has become dislodged from it's groove or damaged. Reposition or replace the gasket as necessary.

CAUSE: The heat exchanger is not fully tightened.

SOLUTION: Count the number of heat transfer plates in the heat exchanger to verify the correct number. Tighten the heat exchanger in accordance with Section 5.2 until the leak stops.

### **NOTICE!**

Do not tighten the heat exchanger more than 1% below the specified tightening dimension or damage to the plates could occur. Consult Graham for proper tightening dimensions if necessary.

CAUSE: A heat transfer plate has been damaged due to overtightening or physical abuse.

SOLUTION: A damaged plate typically must be removed from the heat exchanger and either repaired or replaced. Mark the leaking plate, open the heat exchanger in accordance with Section 5.1, remove the plate and replace it with a new one.

If a replacement plate is not readily available, an option for making the unit operable is as follows;

- 1) Remove the damaged plate.
- 2) If the damaged plate is a standard four hole plate, you should also remove the plate immediately before or after it.
- 3) Close the heat exchanger in accordance with Section 5.2.
- 4) Due to the removal of some plates the heat exchanger must now be tightened to a reduced dimension. Consult Graham engineers for a new appropriate dimension.

CAUSE: A heat transfer plate is misaligned in the heat exchanger.

SOLUTION: Mark and remove the leaking plate. Carefully repair the plate hanging or corner alignment section of the plate so it aligns properly in the heat exchanger. If the plate still hangs incorrectly in the heat exchanger it must be replaced with a new one. Close the heat exchanger in accordance with section 5.2.



SYMPTOM: Fluid is leaking between the first heat transfer plate and the fixed cover or the last plate and the moveable cover.

**CAUSE:** The gasket sealing the heat exchanger heat transfer plate to the cover/connection may have become dislodged, particles could be under the gasket or the gasket sealing surface could be damaged or irregular.

**SOLUTION:** Open the plate heat exchanger in accordance with Section 5.1. Check the sealing area on the inside of the appropriate cover/connection for any irregularities or unusual particles that could cause sealing problems. Make corrections as necessary. Make certain the gasket is in the correct position on the heat exchanger plate and the close the heat exchanger in accordance with Section 5.2.

SYMPTOM: Fluid from one side of the heat exchanger is leaking internally in to the opposing fluid's side with no external leakage.

**CAUSE:** Holes or cracks in the thermal plates caused by corrosion is the most probable cause of this condition. If the unit is piped up incorrectly, immediate cross contamination or mixing of fluids will occur.

**SOLUTION:** Check the setting plan of the heat exchanger to verify it is piped correctly. Shut down the heat exchanger. Drain and remove the piping from one lower connection. Pressurize the remaining closed side of the heat exchanger. A leak will be seen by fluid leaking in to the opened port area . If there is a leak occurring, record which plate is leaking and open the heat exchanger as in Section 5.1.

Start removing the plates and carefully examine them for signs of perforations or cracks; particularly those nearest the marked plate. Use a magnifying glass, dye penetrant testing or a bright light behind the plates for easier leak detection.

Observe the leak detector groove in the gasket as if this has become clogged with deposits it is possible for it to cause cross contamination of the two fluids.

Plates with holes or cracks are not repairable and must be removed and replaced.

In case of an emergency, the heat exchanger can be put back in service with fewer plates by following "Fluid is leaking between two heat transfer plates and to the outside".

SYMPTOM: A fluid is leaking from where the external piping is connected to the heat exchanger.

CAUSE: Either the gasket sealing the flange to the frame has become loose or damaged or in some cases the alloy nozzle liner or stub end has been damaged due to corrosion or excessive loading.

SOLUTION: Shut down the heat exchanger. Drain and remove the piping from the leaking connection. After the piping is removed, if the connection sealing gasket is out of place or damaged carefully replace the gasket. Clean the gasket sealing surface to make certain there is no foreign debris that could cause damage to the gasket or leaks. Reconnect the piping. When the piping is removed, you should also examine the alloy nozzle liner or stub end for any sign of cracks or damage that could cause a leak. If damage is suspected, take the unit apart in accordance with section 5.1. Visually or dye penetrant the liner or stub end for cracks or leaks. The damaged connections should be either repaired or replaced. Close up the heat exchanger in accordance with section 5.2.

SYMPTOM: The pressure drop across the heat exchanger is higher than anticipated.

CAUSE: The heat transfer plates may have become plugged with debris or scaling or the plates may be installed incorrectly. Exchanger may have the incorrect plate pattern(s) installed.

SOLUTION: The pressure drop across the heat exchanger must be accurately measured. Observe the outer edge of plates and confirm they form a honeycomb pattern which indicates they are installed in the correct position.

If available, backflushing the heat exchanger at a high velocity in the reverse direction may dislodge trapped debris. If this is not available or successful, the unit must be disassembled and cleaned.

When disassembled the heat transfer plate pattern can be verified with the plate arrangement drawings.

SYMPTOM: The heat transfer rate of the heat exchanger declines.

CAUSE: The heat transfer plates have become fouled during operation.

SOLUTION: Follow procedures for cleaning the heat exchanger.



### 7.0 Cleaning

#### 7.1 Fouling Types

The rate of fouling in a heat exchanger is dependent on the application and local conditions. This will affect the frequency and type of cleaning required.

By increasing the velocity or flow through the heat exchanger at regular time intervals, some types of fouling may be minimized. The fouling is reduced by creating more turbulence in the heat exchanger that may remove loose scale deposits.

In applications where solids are known to be in the fluids, strainers should be placed in front of the heat exchanger inlet to prevent solids from entering the heat exchanger and becoming plugged in the narrow passages between heat transfer plates.

##### FOULING TYPE: SCALING

Scaling is a common form of fouling in a plate heat exchanger. The cause is high concentrations of calcium, carbonate, calcium, sulphate and/or silicates in the water.

**SOLUTION:** The scale build up can be removed by either chemically cleaning in place ("CIP") or by opening the heat exchanger and physically cleaning each heat transfer plate with a soft brush and running water.

Chemical clean with a solution of 4% maximum nitric acid, sulfamic acid, citric acid, phosphoric acid, complexing agents EDTA and NTA or sodium polyphosphates in water at a maximum temperature of 140 °F.

#### **NOTICE!**

When using cleaning fluids, consult and follow the manufacturer's handling instructions. Wear eye and/or skin protection if required.

##### FOULING TYPE: BIOLOGICAL

Bacteria and other organisms in the water produce biological fouling.

**SOLUTION:** The scale build up can be removed by either chemically cleaning in place ("CIP") or by opening the heat exchanger and physically cleaning each heat transfer plate with a soft brush and running water.

Chemical clean with a solution of 4% maximum sodium hydroxide or sodium carbonate in water at a maximum temperature of 140 °F.



**FOULING TYPE: SEDIMENTARY**

Metal oxides, corrosion products, silt, alumina and diatomic organisms cause sedimentary fouling.

**SOLUTION:** The scale build up can be removed by either chemically cleaning in place ("CIP") or by opening the heat exchanger and physically cleaning each heat transfer plate with a soft brush and running water.

Chemical clean with a solution of 4% maximum nitric acid, sulfamic acid, citric acid, phosphoric acid, complexing agents EDTA and NTA or sodium polyphosphates in water at a maximum temperature of 140 °F.

**FOULING TYPE: RESIDUAL**

Oils, asphalt and fats can leave hydrocarbon deposits classified as residual fouling.

**SOLUTION:** The heat exchanger must be opened and the plates physically cleaned with a soft brush and a paraffinic or naphtha based solvent such as kerosene and then rinsed with water. The gaskets can be damaged by exposure to these solvents so limit cleaning time to one half hour or less.

**FOULING TYPE: GROSS**

Plugging or gross fouling of the heat exchanger is caused by the presence of fibres, assorted solids and/or seaweed in the fluids.

**SOLUTION:** Backflush may work before opening the unit and physically cleaning the plates with a soft brush. A suitable strainer at the inlet to the heat exchanger will prevent this type of fouling.

**7.2 Cleaning Physically**

- 1) The heat exchanger must be opened in accordance with section 5.1 and the plates removed from the frame.
- 2) A water jet can be used to clean the plates but the spray should be directed away from the gaskets to avoid damaging them.
- 3) Clean the plates with a soft brush. Be very careful not to scratch the gasket seating area. Do not use steel brushes or wool as damage to plates can occur.
- 4) Use the appropriate cleaning solution for the type of fouling. See section 7.1.

**NOTICE!**

Always confirm that any cleaning fluid to be used is compatible with the plates and gaskets in the heat exchanger. Consult the local cleaning solution supplier if necessary.

- 4) Apply the cleaning solution to the plates and let stand as necessary. Brush and rinse, if necessary repeat the process.
- 5) When the final brushing is complete, rinse the plates very well with water and wipe them dry with a clean cloth.
- 6) Reassemble heat exchanger in accordance with section 5.2.

There are some additional considerations that should be taken to avoid damaging the heat exchanger during the cleaning process;

- Do not use hydrochloric acids when cleaning stainless steel plates
- Plates can be damaged when cleaned using fluids with a chloride concentration greater than 300 ppm.
- Gaskets will be harmed if fluids such as ketones, halogenated hydrocarbons, aromatics and esters are used as cleaning agents.

**7.3 Cleaning In Place**

One method of keeping a unit prone to clogging from solids and/or sediment clean without opening it is by backflushing;

- Backflushing is done by making provisions in the piping to flow the problem fluid in the opposite direction to it's normal flow.
- The flow rate during backwashing should be 1.5 times the normal flow.
- When using a fluid known to contain particulate, it should be piped to enter the heat exchanger at a lower port so the particulate would get caught in the port area and not make it's way in between the plates.
- Piping the heat exchanger with the ability to reverse the flow direction of both fluids periodically is an alternative to backflushing.

**Cleaning In Place (CIP)** with cleaning agents is recommended for applications where frequent fouling of the heat transfer plates occurs. When the application is extremely corrosive, cleaning in place can prolong the life of the plates.

The following is the procedure for cleaning in place;

- 1) Shut off all the valves and completely drain the heat exchanger.
- 2) Flush both sides of the unit with 100 °F to 120 °F water until the stream is clear and free of any process fluids.
- 3) Drain the rinse water completely from the CIP system.
- 4) Fill the drained CIP system with water and add the appropriate cleaning solution.

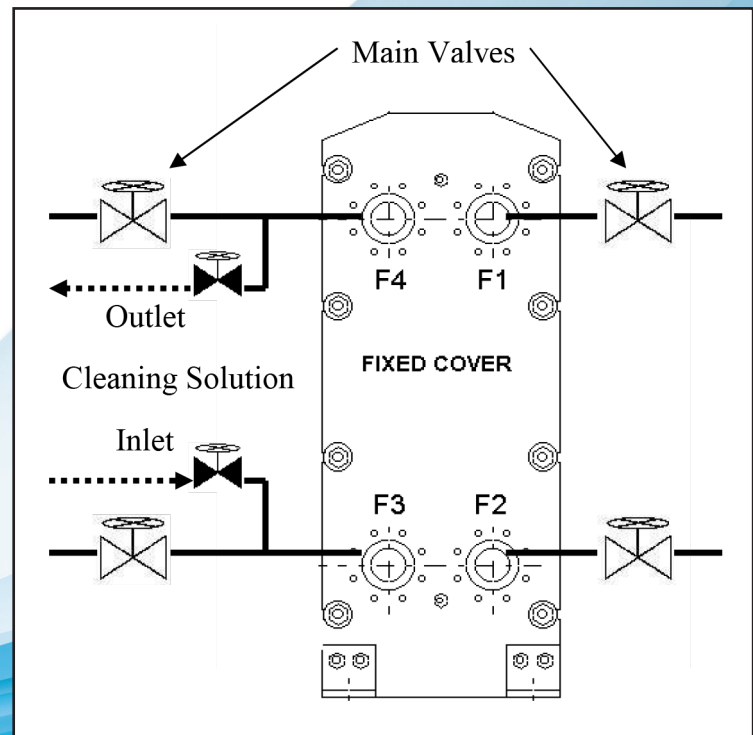

## NOTICE!

Choosing the cleaning solution, duration and temperature of the cleaning procedure is based on The type of fouling. Consult with cleaning fluid supplier to achieve the best results.

- 5) Circulate the cleaning solution through the heat exchanger at 140 °F for 3-6 hours or as recommended by the cleaning solution manufacturer.
- 6) Drain the cleaning solution and flush the unit again with warm water following steps 2 And 3.
- 7) You can now close the valves to the CIP/cleaning solution system and reopen the main Valves to the heat exchanger.
- 8) Start up the heat exchanger in accordance with section 4.2.





**8.0 Flo Fab Inc. Replacement Parts Request Form**

**To: Flo Fab Parts Department**

**Date:**

**Company: Flo Fab Inc.**

**From:**

**Subject: Replacement Parts Price & Availability**

**Fax: 1-450-621-4995**

For best results fax this request to the number shown above. Telephone inquiries can be made through at 1-450-621-2995

When requesting or ordering replacement parts the following information is required;

Heat Exchanger Model:	
Serial Number:	
Complete Plate Pack Required	Yes / No
Complete Gasket Set	Yes / No
or	
No. Plates Required	
No. Gaskets Required	

If individual heat transfer plates or gaskets are required and the serial number is unknown, The following information must be provided;

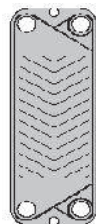
Heat Exchanger Model:	
Plate Material:	
Plate Thickness:	
Plate Style:	H / L
Gasket Material:	
Glueless Gasket:	Yes / No
Indicate Plate Hole Locations:	<div style="display: flex; align-items: center; justify-content: center;"> <span style="margin-right: 10px;">4</span>  <span style="margin-left: 10px;">1</span> </div>
First Plate In Pack:	Yes / No
Last Plate In Pack:	Yes / No

The above information is critical for providing the correct replacement parts.

We are proud supplier for the following completed and on going projects :



**Rutgers University  
Apartments**  
604 Bartholomew Road  
Piscataway, NJ 08854



**Bella Vista Ltd.,**  
26 Torbay Road. St.  
John's, NL. A2A 2G4



**Cité du Nouveau Monde**  
64 rue St-Paul Ouest,  
Montreal, QC, H2Y 1Y8



**Le Murray**  
1169, Rue Ottawa,  
Montréal, QC H3C 1S6

## Sales and Service:

Quebec, Canada  
Tel. : (450) 621-2995  
Fax : (450) 621-4995

Lake Worth  
Florida, USA  
33467-5749

Toronto, Canada  
Tel. : +1 (647) 544-2995

[www.flofab.com](http://www.flofab.com)

SERVICE 24/7 : [parts@flofab.com](mailto:parts@flofab.com)

