



# Heat Exchangers

## Type S & W

Operation, Maintenance  
& Installation Manual



[www.flofab.com](http://www.flofab.com)

001-iom-2017-hesw

Go to [www.flofab.com](http://www.flofab.com) in Our Products Section to see the Master Spec - <http://www.arcomnet.com/masterspec/>

# INDEX

- I. Application
- II. Operating Principle
- III. Construction (Features & Material)
- IV. Operating Parameters & Selection of Heat Exchangers
- V. Installation
- VI. Startup/Shutdown
- VII. Operation
- VIII. Maintenance
- IX. Storage & Transportation
- X. Warranty Terms
- XI. Warranty Claims Form
- XII. Sales & Service

## I. APPLICATION

U-tube heat exchangers are designed for a wide range of liquid to liquid and steam to liquid applications. We offer products of the highest quality and reliability to satisfy your most rigorous demands.

Typical Applications:

- Domestic Hot Water
- Oil Temperature Cooling
- Liquid & Gas Cooling

## II. OPERATING PRINCIPLE

A heat exchanger is a device in which heat is transferred from one flowing fluid to another. Thermal energy is transferred through the tube walls and the total heat load is dependent on the flow parameters of the fluid. Shell and tube heat exchangers are the most common type of heat exchangers for liquid/liquid service, although many applications also involve steam and certain gases.

W-line of heat exchangers is designed for liquid to liquid applications, and our S-line of heat exchangers is designed for steam to liquid applications. Nonnally, the heating medium (e.g. hot water, steam) flows through the shell side, and the heated medium through the tube side, although this can be reversed depending on the application.

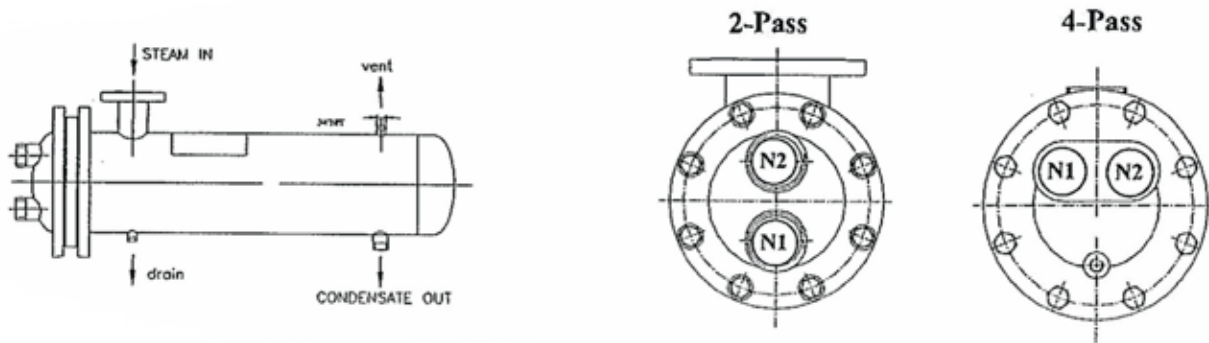

**Figure 1. Flow Distribution in S-model**

*For 4-Pass, N1 and N2 are interchangeable*

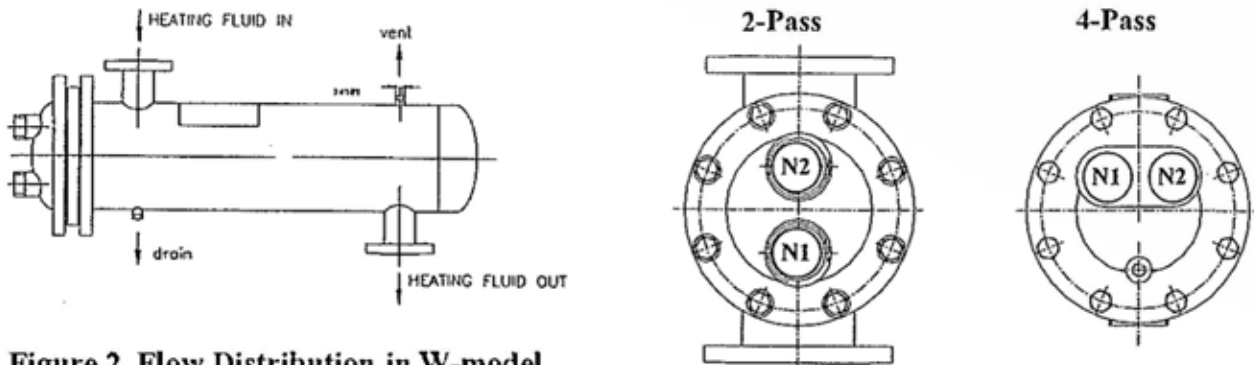

**Figure 2. Flow Distribution in W-model**

N1 - HEATED FLUID IN  
N2 - HEATED FLUID OUT

## III. CONSTRUCTION

### FEATURES

Available in 2 or 4 pass construction, our products are enhanced with stainless steel tubes in the standard construction, rugged cast iron or steel heads, and unique coil and baffle arrangements to optimize the thermal performance of the heat exchangers.

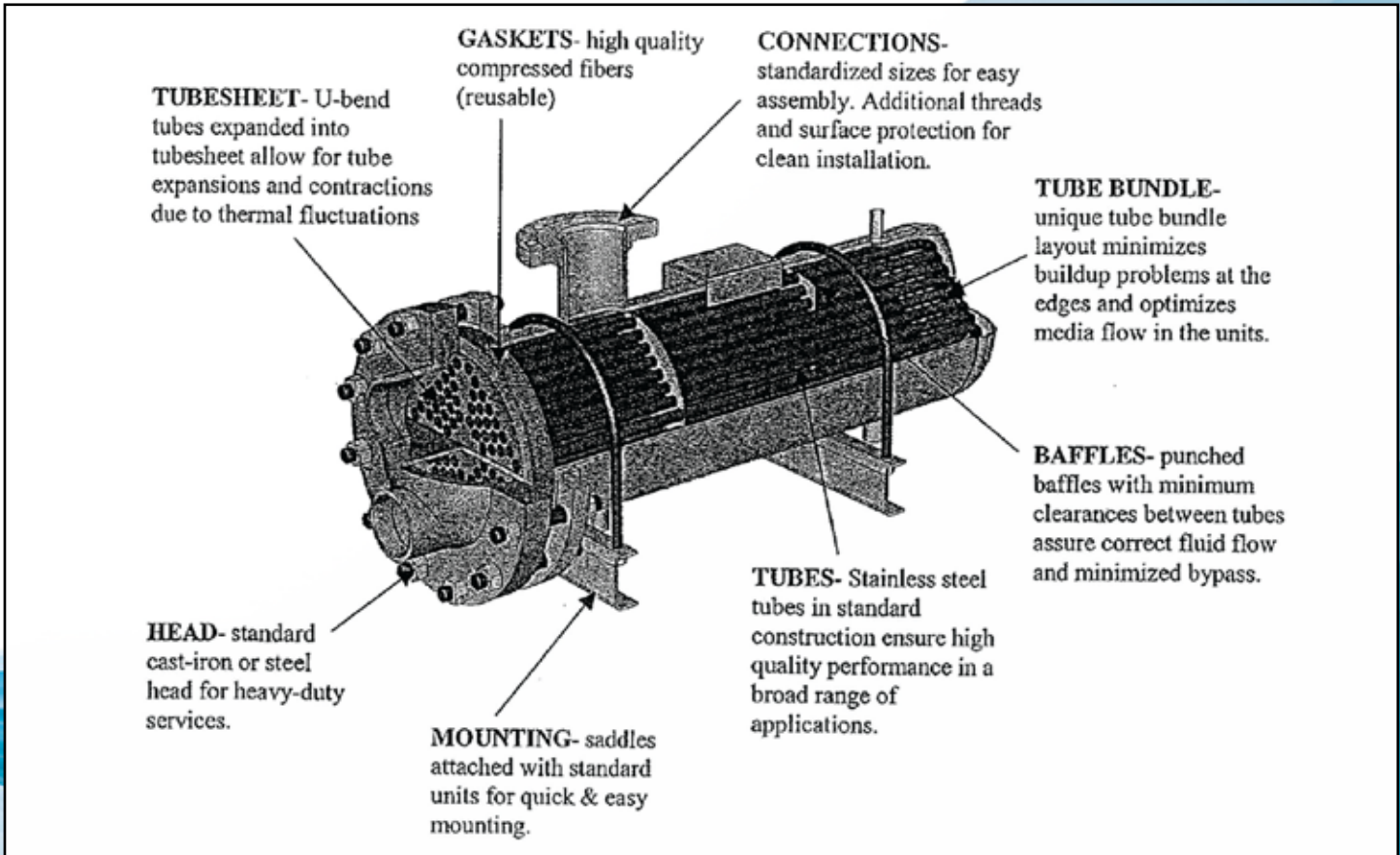

### MATERIAL

S and W-model heat exchangers are manufactured according to the following table, although optional materials of construction are available to suit specific customer requirements.

Materials of Construction		
Sections	Standard Construction	Optional
Shell	Steel	SS304; SS316L
Head	Cast Iron / Steel	SS304; SS316L
Tubes	Stainless Steel (304)	Copper; SS316L; 90/10 CuNi
Tubesheet	Steel	SS304; SS316L
Connections	Steel	SS304; SS316L
Baffle	Teflon	SS304; SS316L
Nuts & Bolts	Steel	-
Gasket	Non-asbestos/pressed fiber	-



## IV. OPERATING PARAMETERS & SELECTION OF HEAT

Standard maximum working parameters of the heat exchangers are as follows:

Standard Design Parameters		
	Pressure (PSI)	Temperature (°F)
Shell	150	375
Tube	150	375

Regardless of the application, proper sizing of a heat exchanger is extremely important in obtaining the desired thermal performance from the unit. In order to select the most appropriate product for an application, a customer should specify the following information:

- type of operating medium/fluids
- required heat load
- required inlet/outlet temperatures of the heating medium required inlet/outlet temperatures
- of the heated medium

Selection is made through an internally developed software program and distributed to our customers.

## V. INSTALLATION

Before installing the heat exchanger into the system, ensure that all the proper piping and safety gauges are in place:

1. Allow enough space around the heat exchanger to provide sufficient clearance to permit the removal of the tube bundle from the shell (for maintenance or inspection purposes).
2. Provide valves and bypasses in the piping system so that both the shell side and tube side may be bypassed to permit isolation of the heat exchanger for inspection, cleaning, and repairs.
3. Provide thermometer wells and pressure gauge pipe taps in all piping to and from the heat exchanger, as close as possible to the unit to detect operating performance of the unit.
4. Provide necessary air vent valves for the heat exchanger so that it can be purged to prevent or relieve vapor or gas binding on both the shell and tube side.
5. Install proper liquid level controls and relieve valves and liquid level and temperature alarms, etc.
6. Install a surge drum upstream from the heat exchanger to guard against pulsation of fluids caused by pumps, compressors, or other equipment.

The S and W-models are designed for horizontal installation. If space is a constraint and vertical installation is required, please inform the sales office.

- Before piping up, inspect all openings in the heat exchanger for foreign material. Remove all plugs and shipping covers immediately prior to installation. Do not expose the interior passages of the heat exchanger to the atmosphere as moisture and contaminants may enter the unit and cause damage to the system.
- Mounting saddles are attached to the standard unit for quick and easy installation.
- When installing, set heat exchanger level to the ground to ensure no excess force is required to connect to the system. Install the heat exchanger in a manner where it will not be exposed to mechanical stresses or moments.

## VI. STARTUP/SHUTDOWN

In all startup and shutdown operations, fluid flows should be gradual and regulated to avoid thermal shocking the unit, and every effort should be made to prevent subjecting the heat exchanger to overpressure or hydraulic hammers, as these conditions may impose stresses on the unit that could result in structural damages.

### Start-Up:

- Valves should be opened gradually in order to achieve a steady increase in flow and pressure into the unit. The pressure increase/decrease should not exceed 72 psi/min (0.5 MPa/min).
- The cold (heated) fluid should first enter into the system.
- The hot (heating) fluid, water or steam, should be gradually brought into the system.
- Check all connections for leaks.

### Shut-Down:

- Shut down hot fluid side first, then the cold fluid side.

## VII. OPERATION

Heat exchangers should be used according to the specifications given and within pressure and temperature ranges not exceeding the limits set forth in the section «Operating Parameters & Selection of Heat Exchangers».

1. Ensure that the system is clean of debris before starting operation to prevent clogging of tube and shell side passages.
2. Open vent connections before starting up.
3. Follow the instructions in the section «Startup/Shutdown».
4. After the system is completely filled with the operating fluid, close all manual vent connections.
5. Do not operate the heat exchanger under pressure and temperature conditions exceeding the maximum allowable limit (as specified on the nameplate).
6. Prevent any of the fluids from dropping below their freezing point.
7. Drain all fluids when shutting down to prevent possible freezing and corrosion.



Under no circumstances should there be pulsating of fluids, as this causes vibrations that could damage the structural integrity of the heat exchanger. The system should be designed to prevent the unit from encountering pressure shocks and rapid temperature changes.

## VIII. MAINTENANCE

### CLEANING

Clean heat exchangers subject to fouling (scale buildup, sludge deposits, hard water deposits, tarnishes, etc.) periodically, depending on operating conditions. Fouling in the unit can result in increased pressure drops, low temperature differential in the heated medium, or a higher exit temperature on the heating medium side.

To clean or inspect the tubes, it may be necessary to remove the tube bundle from the shell. When removing the tube bundle, ensure that there is no damage due to improper handling:

- The weight of the tube bundle should not be supported by individual tubes, but should be carried by the tubesheet, support or baffle plates.
- Do not handle the tube bundle with hooks or other tools that can damage the tubes.
- To withdraw the tube bundle, pass rods through two or more of the tubes and take the load on the tubesheet, or alternatively, thread a steel cable through one tube and return through another tube.
- Lift tube bundles horizontally by means of a cradle formed by bending a light-gauge plate into a u-shape.
- Do not drag the bundles, as this may cause damage to the tubes and baffles.

Cleansing of the heat exchanger can be done without removing the tube bundles or the unit from the system, although extra connections and bypasses would be required.

The cleaning solutions are readily assessable at businesses carrying chemical cleaning agents for heat exchangers or tubing and piping applications. As a guideline to purchasing the cleaning solutions, check for the following product data:

- compatibility with the material of construction (steel, stainless steel, copper, etc.)
- acceptable for use in food processing industries (if applicable)
- effectively removes scale, slag, tarnishes, and hard water deposits
- easily rinsed out of the system
- no objectionable or corrosive fumes

### **The following fluids are prohibited for use as a flushing agent!!**

- **Hydrochloric acid up to 0.1 % concentration**
- **Solutions that contain MCI**
- **Chlorides (MgCl<sub>2</sub>, NaCl between 0.01-1 %, Cu Cl up to 1 %, CaCl<sub>2</sub> from 5% to saturation)**
- **Any fluid that will deposit alkaline residue or phosphorous**

## LEAKS

To locate ruptured or corroded tubes or leaking joints between tubes and tubesheet, the following procedure is recommended:

- Drain the heat exchanger completely of any fluid or moisture.
- Pressurize the shell side of the unit with fluid (e.g. water, glycol, etc.)
- Observe the tube joints and tube ends for indication of test fluid leakage

## IX. STORAGE & TRANSPORTATION

During transportation of the heat exchangers, ensure that they are not exposed to mechanical damages. Upon receipt of the heat exchanger, inspect the unit for shipping damages. Notify the carrier or the sales office immediately in the event that such damages do occur.

Heat exchangers should be stored in a clean, dry, low humidity area away from corrosive environments or weather elements (e.g. rain, snow, blowing dust). If the unit is not to be placed in immediate service, take precautions to prevent rusting or contamination. Heat exchangers that are out of service for extended periods of time should be protected against corrosion.

### CLEANING:

Shell and tube bundle should be flushed out periodically. If cleaning is necessary, remove head and bundle to clean inside of shell and outside of tubes. Replace gaskets if necessary. If unit is installed in a hard water area, inside of tubing can be cleaned as follows:

1. Break water connections and plug bottom opening.
2. Fill the tubes with a solution of 1 part muriatic acid to 10 parts of water and allow to stand for 2 hours:  
CAUTION: A longer period may cause damage to the copper tubing.
3. Drain off and flush thoroughly with clean water.
4. Re-assemble unit.

### Note:

Commercially available cleaners may also be used.

### REPLACEMENT PARTS:

When ordering replacement parts specify:

1. Complete Model Number
2. Date of Manufacture
3. Special Materials if Required

Normally, the only replacement parts required would be:

- 1 - Tube Bundle
- 1 - Set of Gaskets

Replacement heads are also available if required.



We are proud supplier for the following  
completed and on going projects :



**Rutgers University  
Apartments**  
604 Bartholomew Road  
Piscataway, NJ 08854



**Bella Vista Ltd.,**  
26 Torbay Road. St.  
John's, NL. A2A 2G4



**Cit  du Nouveau Monde**  
64 rue St-Paul Ouest,  
Montreal, QC, H2Y 1Y8



**Le Murray**  
1169, Rue Ottawa,  
Montr al, QC H3C 1S6

## Sales and Service:

Quebec, Canada  
Tel. : (450) 621-2995  
Fax : (450) 621-4995

Lake Worth  
Florida, USA  
33467-5749

Toronto, Canada  
Tel. : +1 (647) 544-2995

[www.flofab.com](http://www.flofab.com)

SERVICE 24/7 : [parts@flofab.com](mailto:parts@flofab.com)

