

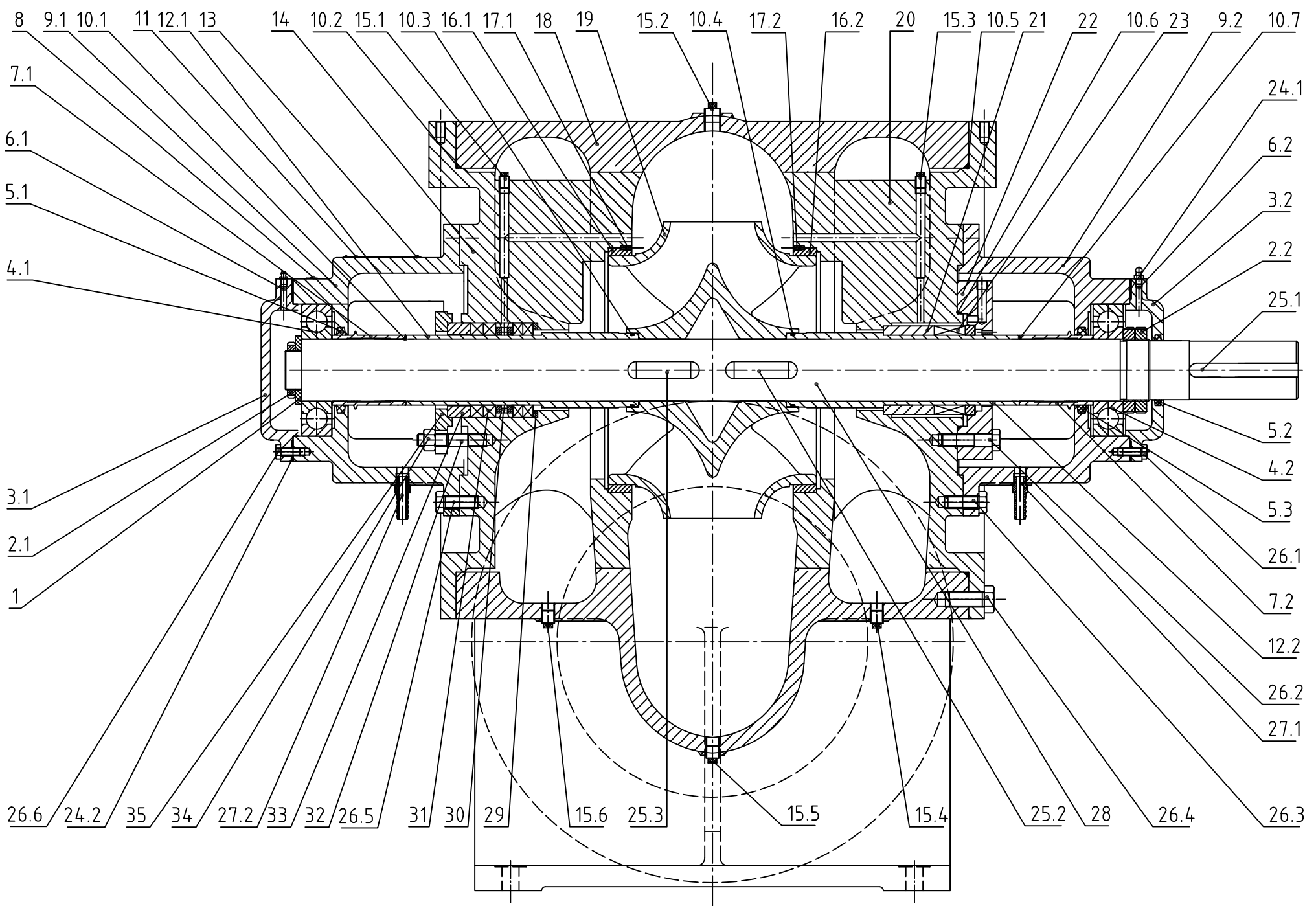

4800U & L SERIES, TYPICAL SECTIONAL DRAWING (GREASE LUBRICATION)



No.	Parts Name	Material	No.	Parts Name	Material	No.	Parts Name	Material	No.	Parts Name	Material
1	Disc Ring	60Si2MnA	10	O-ring	Buna-Nrubber	19	Impeller	Cast Iron GG25	28	Shaft	45 Carbon Steel
2	Round Nut	45 Carbon Steel	11	Name Plate	1mm Alumsheet	20	Pump Cover B	Cast Iron GG20	29	Neck-ring/Packing	Cast Iron GG20
3	Bearing Cover	Cast Iron GG20	12	Shaft Sealing Sleeve	AlSI 420 2Cr13	21	Neck-ring/Mech-seal	Cast Iron GG20	30	Lantern Ring	Cast Iron GG20
4	Deep Groove Ball Brq.	GCr15	13	Rivet 2x6	H62	22	Mech-seal Cover	Cast Iron GG20	31	Packing	PTFE
5	Radial Shaft Seal Ring	Wool Felt	14	Pump Cover A	Cast Iron GG20	23	Mechanical Seal	SiC-C	32	Stud Bolt	4.8
6	Grease Fitting	Copper Alloy	15	Square Plug	KTH300-06	24	Brq. Cover Gasket	0.2mm Paper	33	Split Ring	Cast Iron GG20
7	Brq. Spacer Sleeve	Cast Iron GG25	16	Casing Wearing	Cast Iron GG25	25	Key	45 Carbon Steel	34	Nut	6
8	Arrow Plate	1mm Alumsheet	17	Screw	14H	26	Screw Bolt	4.8	35	Gland	Cast Iron GG25
9	Brq. Housing	Cast Iron GG20	18	Pump Casing	Cast Iron GG20	27	Pipe Joint	Q235-A Carbon Steel			