

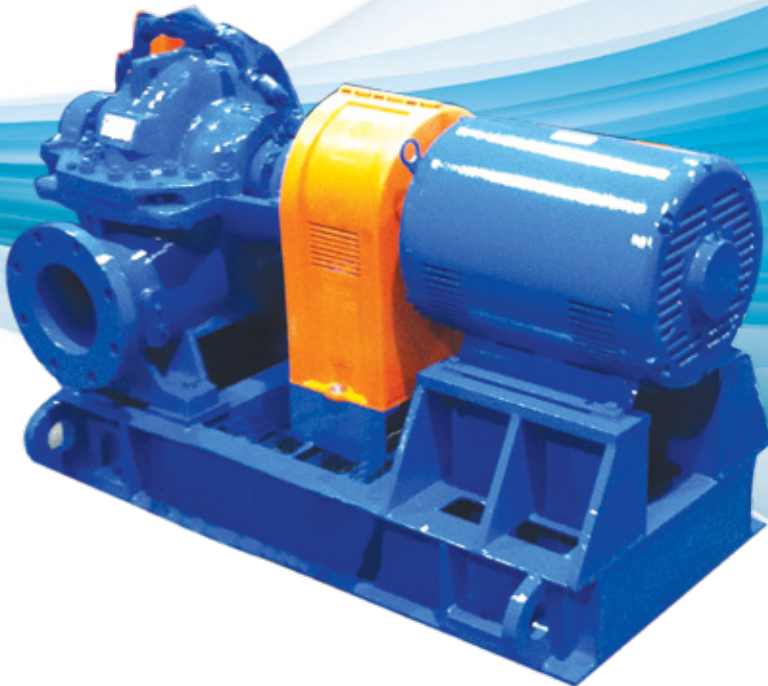

# Double Suction Split Case Series 4900VH

Operation, Maintenance  
& Installation Manual



[www.flofab.com](http://www.flofab.com)

001-iom-2017-4900vh

Go to [www.flofab.com](http://www.flofab.com) in Our Products Section to see the Master Spec - <http://www.arcomnet.com/masterspec/>

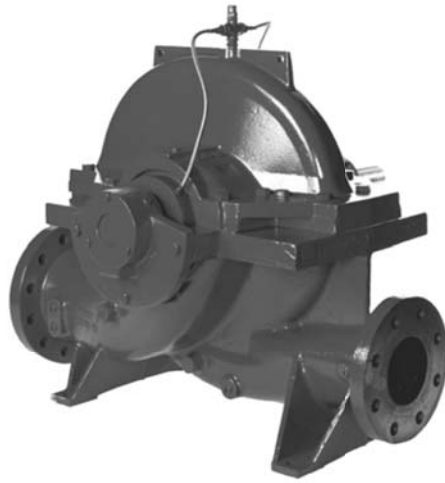

**Horizontal  
Volute  
casing  
pump**

with radial impeller



**These operating instructions contain fundamental information and precautionary notes. Please read the manual thoroughly prior to installation of unit, electrical connection and commissioning. It is imperative to comply with all other operating instructions referring to components of individual units.**



**Any work on the unit must only be carried out with the electrical connections (incl. control cable) disconnected (or unplugged). Make sure that the pump set cannot be switched on accidentally.**

<b>Contents</b>		<b>Page</b>
<b>1</b>	<b>General</b> .....	<b>3</b>
<b>2</b>	<b>Safety</b> .....	<b>3</b>
2.1	Marking of Instructions in the Manual .....	3
2.2	Personnel Qualification and Training .....	3
2.3	Non-Compliance with Safety Instructions .....	3
2.4	Safety Awareness .....	3
2.5	Safety Instructions for the Operator / User .....	4
2.6	Safety Instructions for Maintenance, Inspection and Installation Work .....	4
2.7	Unauthorized Modification and Manufacture of Spare Parts .....	4
2.8	Unauthorized Modes of Operation .....	4
<b>3</b>	<b>Transport and Interim Storage</b> .....	<b>4</b>
3.1	Transport .....	4
3.2	Interim Storage / Preservation .....	5
<b>4</b>	<b>Description of the Product and Accesories</b> .....	<b>5</b>
4.1	Technical Specification .....	5
4.2	Designation .....	6
4.3	Design Details .....	6
4.4	Types of Installation .....	6
4.5	Accessories (optional) .....	6
4.6	Dimensions and Weights .....	6
<b>5</b>	<b>Installation at Site</b> .....	<b>6</b>
5.1	Safety Regulations .....	6
5.2	Checks to Be Carried out Prior to Installation .....	6
5.3	Installing the Pump / Unit .....	7
5.4	Connecting the Piping .....	7
5.5	Final Check .....	7
<b>6</b>	<b>Commissioning, Start-up / Shutdown</b> .....	<b>8</b>
6.1	Commissioning .....	8
6.2	Shaft Seal .....	8
6.3	Venting .....	8
6.4	Commissioning .....	8
6.5	Shutdown / Storage / Preservation .....	9
6.6	Returning to Service after Storage .....	9
<b>7</b>	<b>Maintenance / Repair</b> .....	<b>9</b>
7.1	General Instructions .....	9
7.2	Maintenance / Inspection .....	10
7.3	Dismantling .....	10
7.4	Reassembly .....	11
7.5	Instructions for Replacing Subassemblies .....	13
7.6	Monitoring schedule .....	14
<b>8</b>	<b>Special Instructions for Subassemblies (Shaft Seal Variants)</b> .....	<b>15</b>
8.1	Mechanical Seal Variants (Mech. Seal Size / Pump Size Combinations) .....	15
<b>9</b>	<b>Spare Parts</b> .....	<b>29</b>
<b>10</b>	<b>Forces and Moments</b> .....	<b>30</b>
<b>11</b>	<b>Trouble-Shooting</b> .....	<b>31</b>
11.1	General .....	31
11.2	Trouble-shooting Table .....	32
<b>12</b>	<b>Routine Maintenance and Inspection Intervals</b> .....	<b>36</b>
<b>13</b>	<b>Appendix</b> .....	<b>37</b>

## 1 General

**This Flo Fab pump has been developed in accordance with state-of-the-art technology; it is manufactured with utmost care and subject to continuous quality control.**

These operating instructions are intended to facilitate familiarization with the pump and its designated use.

The manual contains important information for reliable, proper and efficient operation. Compliance with the operating instructions is of vital importance to ensure reliability and a long service life of the pump and to avoid any risks.

These operating instructions do not take into account local regulations; the operator must ensure that such regulations are strictly observed by all, including the personnel called in for installation.

This pump / unit must not be operated beyond the limit values specified in the technical documentation for the medium handled, capacity, speed, density, pressure, temperature and motor rating. Make sure that operation is in accordance with the instructions laid down in this manual or in the contract documentation.

The name plate indicates the type series / size, main operating data and works / series number; please quote this information in all queries, repeat orders and particularly when ordering spare parts.

If you need any additional information or instructions exceeding the scope of this manual or in case of damage please contact Flo Fab's nearest representative.

## 2 Safety

These operating instructions contain fundamental information which must be complied with during installation, operation and maintenance. Therefore this operating manual must be read and understood both by the installing personnel and the responsible trained personnel / operators prior to installation and commissioning, and it must always be kept close to the location of operation of the machine / unit for easy access.

Not only must the general safety instructions laid down in this chapter on "Safety" be complied with, but also the safety instructions outlined under specific headings.

### 2.1 Marking of Instructions in the Manual

The safety instructions contained in this manual whose non-observance might cause hazards to persons are specially marked with the general hazard sign, namely



safety sign in accordance with DIN 4844 – W9.

The electrical danger warning sign is



safety sign in accordance with DIN 4844 – W8.

The word

**Caution**

is used to introduce safety instructions whose non-observance may lead to damage to the machine and its functions.

Instructions attached directly to the machine, e.g.

- arrow indicating the direction of rotation
- markings for fluid connections

must always be complied with and be kept in perfectly legible condition at all times.

### 2.2 Personnel Qualification and Training

All personnel involved in the operation, maintenance, inspection and installation of the machine must be fully qualified to carry out the work involved.

Personnel responsibilities, competence and supervision must be clearly defined by the operator. If the personnel in question is not already in possession of the requisite know-how, appropriate training and instruction must be provided. If required, the operator may commission the manufacturer / supplier to take care of such training. In addition, the operator is responsible for ensuring that the contents of the operating instructions are fully understood by the responsible personnel.

### 2.3 Non-Compliance with Safety Instructions

Non-compliance with safety instructions can jeopardize the safety of personnel, the environment and the machine itself. Non-compliance with these safety instructions will also lead to forfeiture of any and all rights to claims for damages.

In particular, non-compliance can, for example, result in:

- failure of important machine / unit functions
- failure of prescribed maintenance and servicing practices
- hazard to persons by electrical, mechanical and chemical effects
- hazard to the environment due to leakage of hazardous substances

### 2.4 Safety Awareness

It is imperative to comply with the safety instructions contained in this manual, the relevant national health and safety regulations and the operator's own internal work, operation and safety regulations.

**2.5 Safety Instructions for the Operator / User**

- Any hot or cold components that could pose a hazard must be equipped with a guard by the operator.
- Guards which are fitted to prevent accidental contact with moving parts (e.g. coupling) must not be removed whilst the machine is operating.
- Leakages (e.g. at the shaft seal) of hazardous media handled (e.g. explosive, toxic, hot) must be contained so as to avoid any danger to persons and the environment. Pertinent legal provisions must be adhered to.
- Electrical hazards must be eliminated. (In this respect refer to the relevant safety regulations applicable to different countries and/or the local energy supply companies.)

**2.6 Safety Instructions for Maintenance, Inspection and Installation Work**

The operator is responsible for ensuring that all maintenance, inspection and installation work be performed by authorized, qualified specialist personnel who are thoroughly familiar with the manual.

Work on the machine must be carried out only during standstill. The shutdown procedure described in the manual for taking the machine out of service must be adhered to without fail.

Pumps or pump units handling media injurious to health must be decontaminated.

Immediately following completion of the work, all safety-relevant and protective devices must be re-installed and/or re-activated.

Please observe all instructions set out in the chapter on "Commissioning" before returning the machine to service.

**2.7 Unauthorized Modification and Manufacture of Spare Parts**

Modifications or alterations of the machine are only permitted after consultation with the manufacturer. Original spare parts and accessories authorized by the manufacturer ensure safety. The use of other parts can invalidate any liability of the manufacturer for consequential damage.

**2.8 Unauthorized Modes of Operation**

The warranty relating to the operating reliability and safety of the pump / unit supplied is only valid if the machine is used in accordance with its designated use as described in section 1 of these operating instructions. The limits stated in the data sheet must not be exceeded under any circumstances.

**3 Transport and Interim Storage**

**3.1 Transport**

Transport of the unit requires proper preparation and handling. Always make sure that the pump or the unit remains in horizontal position during transport and cannot slip out of the transport suspension arrangement. Do not use lifting slings on the free shaft end of the pump or on the motor eyebolt.

 Also make sure that the coupling guard is not damaged by the sling arrangement. If the pump / unit slips out of the suspension arrangement, it may cause personal injury and damage to property.

Transport in horizontal position is recommended in all cases, since this ensures stable positioning of the unit without any risk of accident, whatever the method of transport, e.g. road, rail or ship, etc.

For transport purposes the unit shall be secured on suitable pallets or sleds. All loose and movable parts must be secured.

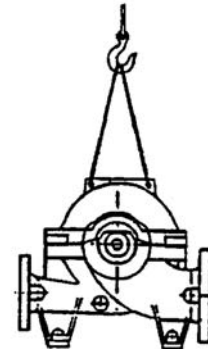

Fig.1: Transport of pump

(Fig.0)

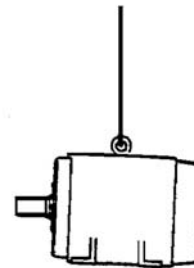



Fig.2: Transport of motor

 The motor eyebolts must only be used for lifting the motor alone, never for lifting the complete unit.

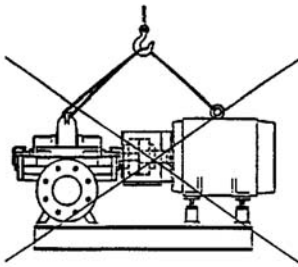

Fig.3: **Never** transport the unit as shown above!

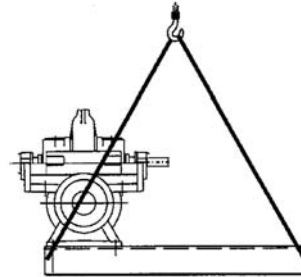

Fig.4c: Transport of unit (without motor)  
 - motor sizes 445T and above  
 - or total weight (unit) of 3300lbs and above



Safe transport in horizontal position must be ensured by suitable transport facilities. Make sure the pump cannot slip out of the transport arrangement.

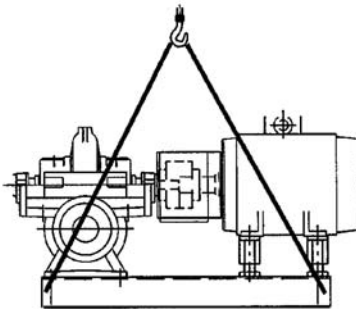

Fig.4a: Transport of complete unit (horizontal installation type H)  
 - up to motor size 405T (NEMA standard)  
 - or up to a total weight of 3300lbs  
  
 Observe angles of pull when lifting.  
 Angle of pull > 90° not permitted.  
 Use two separate sets of lifting slings!

**3.2 Interim Storage / Preservation**

When the unit is temporarily put into storage, only the wetted low alloy components, e.g. JL1040 (GG-25) must be preserved. Commercially available preservatives can be used for this purpose. Please observe the manufacturer's instructions for application / removal.

**4 Description of the Product and Accesories**

**4.1 Technical Specification**

**Design**

The Flo Fab pump of the 4800/4900H series is a horizontally installed, single-stage, axially split volute casing pump with double-en-try radial impeller. Connection flanges are manufactured according to EN, DIN, ISO, BS or ASME, as preferred.

**Fields of application**

In waterworks, irrigation and drainage pumping stations, power stations, for industrial water supply, dock installations, fire extinguishing systems, refineries, pipelines and tank farms, also for handling crude oil and refinery intermediates

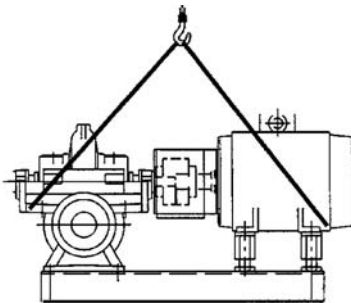
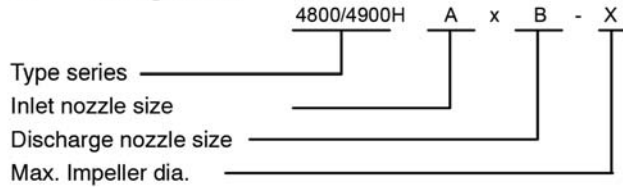

Fig.4b: Transport of complete unit  
 - up to motor size 405T (NEMA standard)  
 - or up to a total weight of 3300lbs

**4.2 Designation**



**4.3 Design Details**

**4.3.1 Pump Casing**

Axially split volute casing with replaceable casing wear rings. Suction and discharge nozzles in lower half of casing are at the same level (inline version).

**4.3.2 Impeller**

The double-entry radial impeller is manufactured for the operating data provided in each case. Also with impeller wear rings, if requested.

In double-entry radial impellers the axial thrust is largely balanced.

**4.3.3 Pump Shaft**

The shaft is fully sealed against the liquid being pumped. Shaft-protecting sleeves are fitted in the seal area.

**4.3.4 Shaft Seal**

The shaft seals at the drive end and non-drive end are gland packings or mechanical seals, as requested.

**4.3.5 Bearings and Lubrication**

The pump is fitted with covered deep-groove ball bearings which are grease-lubricated for life.

The fixed bearing at the non-drive end is located on a bush to permit rapid changing without removing the rotor or upper half.

**4.4 Types of Installation**

The pump set is installed in configuration H - horizontal installation, direct-coupled (see appendix).

**4.5 Accessories (optional)**

The following accessories are available:

Accessories	Configuration	
	Fig.0	H
Motor	--	x <sup>1)</sup>
Baseplate/baseframe	--	x <sup>1)</sup>
Coupling and coupling guard	--	x <sup>1)</sup>
Sealing and flushing water piping	x	x
Set of pressure gauges	x	x
Cyclone separator with pipework	x	x
Vent valve (manual or automatic)	x	x
Temperature sensor for rolling element bearings (PT 100)	x	x
Signal transmitter for PT 100	x	x
Drain line	x	x

<sup>2)</sup> included in standard scope of supply

**4.6 Dimensions and Weights**

For dimensions and weights please refer to the tables in the appendix.

**5 Installation at Site**

**5.1 Safety Regulations**



**Electrical equipment operated in "zone 1" hazardous locations must comply with the explosion protection regulations. This is indicated on the motor rating plate.**

If the equipment is installed in hazardous locations, the applicable local explosion protection regulations and the regulations of the test certificate supplied with the equipment and issued by the responsible approval authorities must be observed and complied with.

The test certificate must be kept close to the location of operation for easy access (e.g. foreman's office).

**5.2 Checks to Be Carried out Prior to Installation**

All structural work required must have been prepared in accordance with the dimensions and loads stated in the dimension table / installation plan.

**The concrete foundations shall have sufficient strength (min. BN 25) to ensure safe and functional installation in accordance with DIN 1045 or equivalent standards.**

Make sure that the concrete foundation has set firmly before placing the unit on it. Its surface shall be truly horizontal and even.

### 5.3 Installing the Pump / Unit

**Caution** Before setting up the pump, check the operating data. Ensure that the data on the name plate matches the data in the order and the system data, e.g. operating voltage, frequency, pumped liquid temperature etc.

After placing the pump on the foundation, align it with the help of a spirit level. Shims shall be fitted between the baseplate and the foundation itself; they shall always be inserted to the left and right of the foundation bolts and in close proximity to these bolts. For a bolt-to-bolt clearance of more than 39-3/8", additional shims shall be inserted halfway between the adjoining holes. All shims must lie perfectly flush.

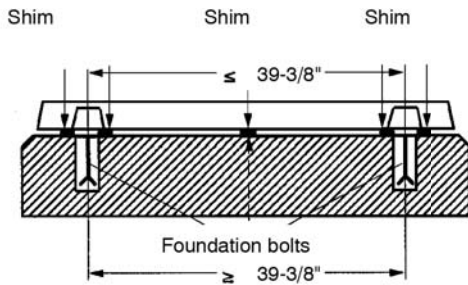

Fig.5: Fitting required shims

Insert the foundation bolts and set them into the foundation using concrete. When the concrete has set, align the baseplate as described in section 5.3.2 and tighten the foundation bolts evenly and firmly. Then grout the baseplate using low shrinkage concrete, making sure no cavities remain.

#### 5.3.1 Removing Rotor Lock

This is not necessary for a horizontally installed pump, since no locking device is fitted.

#### 5.3.2 Aligning the Pump / Drive

**!** Improper alignment of the unit can cause damage to both the coupling and the unit itself!

A pump set in horizontal installation type H is correctly aligned, if a straight-edge placed axially on both coupling halves is the same distance from each shaft at all points around the circumference. In addition, the distance between the two coupling halves must remain the same all around the circumference. Use a feeler gauge, a wedge gauge or a dial micrometer to verify (see fig. 6).

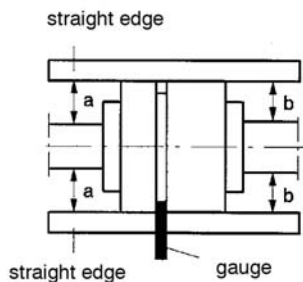

Fig.6: Coupling alignment, using gauge and straight edge  
Special instructions see appendix

### 5.4 Connecting the Piping

**Caution** Never use the pump itself as an anchorage point for the piping.

Suction lift lines shall be laid with a rising slope towards the pump and suction head lines with a downward slope towards the pump. The pipelines shall be anchored in close proximity to the pump and connected without transmitting any stresses or strains. Their weight must not exert any load on the pump. With short pipelines, the nominal diameters shall be at least equal to the nominal diameters of the pump nozzles. For long pipelines the most economical nominal diameter has to be determined from case to case.

**Any additional loads on the discharge and suction nozzles, e.g. caused by:**

Weight of the water-filled pipes, changes in the length of pipes owing to temperature fluctuations, reaction forces due to unbraced expansion joints must not exceed the values stated in the installation plan.

**!** An excessive, impermissible increase in the pipeline forces may cause leaks on the pump where the medium handled can escape into the atmosphere.  
**Danger of life when hot media are handled!**

The flange covers on the pump suction and discharge nozzles must be removed prior to installation in the piping.

#### 5.4.1 Auxiliary Connections

The locations of the auxiliary connections (sealing liquid, flushing liquid, etc.) are indicated on the installation plan or piping layout (see appendix).

Please refer to the appendix for detailed assembly instructions.

**Caution** These connections are required for proper functioning of the pump and are therefore of vital importance!

#### 5.4.2 Coupling Guard

**!** In compliance with the accident prevention regulations the pump must not be operated without a coupling guard. If the customer specifically requests not to include a coupling guard in our delivery, then the operator must supply one.

### 5.5 Final Check

Re-check the alignment as described in section 5.3.2. It must be easy to rotate the shaft by hand at the coupling.

**Caution** Check the integrity and proper functioning of all connections.



## 6 Commissioning, Start-up / Shutdown

**Caution** Compliance with the following requirements is of paramount importance. Damage resulting from non-compliance shall not be covered by the scope of warranty.

### 6.1 Commissioning

Before starting up the pump make sure that the following requirements have been checked and fulfilled:

- Has the pump been firmly bolted to the foundation?
- Have the coupling and pump unit been aligned as specified?
- Can the unit be easily rotated by hand at the coupling? (Carry out at least one full rotation)
- Are the pipes properly fitted?
- Has the coupling guard been fitted?
- Have staff been informed about sources of danger and measures been taken to comply with the accident prevention regulations?
- Correct start-up procedure for suction lift operation.
- Is the unit protected against overload (appropriate safety valve)?
- Have the seals been fitted as described in the appendix?
- Have any additional devices been prepared and fitted as specified in the appendix?
- Has the pump been vented as specified in section 6.3.?

### 6.2 Shaft Seal

For commissioning the shaft seal please refer to section 8.1 / 8.2. If the pump has been out of service for a prolonged period, the measures specified in section 6.6 must be carried out.

### 6.3 Venting

Before start-up, the pump and the pipes must be vented and filled with the liquid to be pumped. This is done at the vent plug on the casing (903). For suction lift operation, the pump must also be evacuated, i.e. a vacuum must be produced.

### 6.4 Commissioning

#### 6.4.1 Checking the Direction of Rotation

**Caution** For trouble-free operation of the pump, the correct direction of rotation of the impeller is of paramount importance.

If running in the wrong direction of rotation, the pump cannot reach its duty point; vibrations and overheating will be the consequence. The unit or the shaft seal might be damaged.

#### Correct direction of rotation:

The direction of rotation must correspond to the direction indicated by the arrow on the pump. This can be verified by switching the pump on and then off again immediately.



Before checking the direction of rotation make sure that there is no foreign matter in the pump casing.

**Never put your hands or any other objects into the pump!**

#### 6.4.2 Start-up

##### Caution

If a non-return valve is not fitted at the discharge-side, close the discharge-side gate valve.

If a shut-off valve is fitted in the suction line, open it fully.

All additional connections for flushing or sealing liquid etc., if fitted, must be opened fully and the flow must be checked.

Switch on the motor.

As soon as the pump starts to deliver – this can be recognised by the rising gauge pressure – slowly open the discharge-side gate valve fully.

##### Caution

The pump may operate against the closed gate valve only during start-up and shutdown, as otherwise inadmissible temperature rise occurs resulting in damage.

#### 6.4.3 Pump Operating Range

The flow rate "Q" adjusts itself automatically to the delivery head according to the H-Q characteristic. The pump's permitted operating range is subject to limits, which have separate causes.

1. Part load operating limit for low flow rate

This limit is indicated in the H-Q characteristic by  $Q_{min}$  or by the discontinuation of the characteristic curve.

##### Caution

It is not permissible to operate the pump in the range from  $Q=0$  to  $Q_{min}$ . Prolonged operation in this range causes greatly increased mechanical loads which the components cannot withstand.

Brief passage through the critical range is permissible, e.g. during start-up

2. NPSH-related limits in the part load and overload ranges

These two limits are determined by the ratio of  $NPSH_{required}$  to  $NPSH_{available}$ . They are determined as follows:

The intersections of  $NPSH_{required}$  and  $NPSH_{available}$  are projected onto the H-Q characteristic, where they indicate the operating limits (refer to the diagram below). Checking of the NPSH-related operating limit is not necessary for operating the pump under design conditions. If system-related changes occur, an NPSH check must be carried out. If necessary, consult the nearest after-sales service centre.

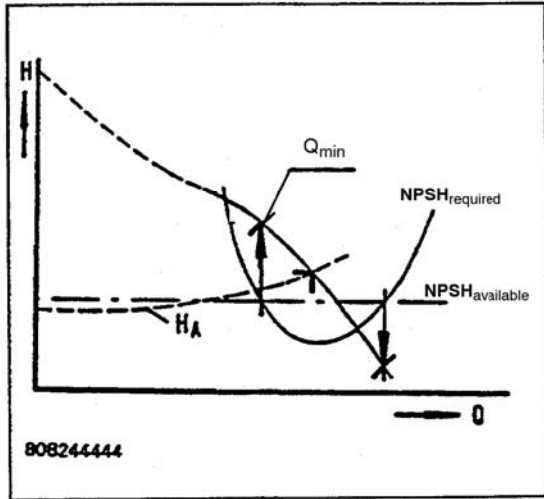

#### 6.4.4 Shutdown

Close the shut-off element in the discharge line. If the discharge line is equipped with a check valve, the shut-off element may remain open, provided there is back pressure in the line.

The shut-off element in the suction line must not be closed when switching off the pump. Switch off the motor, making sure that the unit runs smoothly down to a standstill.

Depending on the system the pump shall have an adequate after-run period - with the heat source switched off - to allow the medium handled to cool down sufficiently to avoid any heat build-up within the pump.

In the case of prolonged shutdown, the shut-off element in the suction line has to be closed.

Close the auxiliary connections.

In the event of frost and / or prolonged shutdowns, the pump must be drained or otherwise protected against freezing.

### 6.5 Shutdown / Storage / Preservation

Each Flo Fab pump leaves the factory carefully assembled. If commissioning is to take place some time after delivery, we recommend that the following measures be taken for pump storage.

#### 6.5.1 Storage of New Pumps

- New pumps are supplied by our factory duly prepared for storage.  
Maximum protection for up to 12 months, if the pump is properly stored indoors.
- Store the pump in a dry location.

### 6.5.2 Measures to be Taken for Prolonged Shutdown

#### 1. The pump remains installed; periodic check of operation

In order to make sure that the pump is always ready for instant start-up and to prevent the formation of deposits within the pump and the pump intake area, start up the pump set regularly once a month or once every 3 month for a short time (approx. 5 minutes) during prolonged shutdown periods. Prior to an operation check run ensure that there is sufficient liquid available for operating the pump.

#### 2. The pump is removed from the pipe and stored

Before putting the pump into storage carry out all checks specified in sections 7.1 to 7.4. Then apply appropriate preservatives:

- Spray-coat the inside wall of the pump casing, and in particular the impeller clearance areas, with a preservative. Spray the preservative through the suction and discharge nozzles. It is advisable to close the nozzles (for ex. with plastic caps or similar).

### 6.6 Returning to Service after Storage

Before returning the pump to service carry out all checks and maintenance work specified in sections 5.1 and 5.2.

In addition, the instructions laid down in section 6.1 "Commissioning" and section 6.4.3 "Operating limits" must be observed.

Upon completion of the work, all safety-related and protective equipment must be properly refitted and / or reactivated before starting the pump set.

## 7 Maintenance / Repair

### 7.1 General Instructions

The operator is responsible for ensuring that all maintenance, inspection and installation work is carried out by authorized, duly qualified staff who are thoroughly familiar with these operating instructions.

A regular maintenance schedule will help avoid expensive repairs and contribute to trouble-free, reliable operation of the pump with a minimum of maintenance expenditure and work.

**Work on the pump and the motor must only be carried out with the electrical connections disconnected. Make sure that the pump set cannot be switched on accidentally (danger of life!).**

Pumps handling liquids posing health hazards must be decontaminated. When draining the medium see to it that there is no risk to persons or the environment. All relevant laws must be adhered to (danger of life!).

## 7.2 Maintenance / Inspection

### 7.2.1 Supervision of Operation

**Caution** The pump shall run quietly and free from vibrations at all times. The pump must never be allowed to run dry.

 Prolonged operation against a closed shut-off element is not permitted in order to prevent the medium handled from heating up.

At room temperatures of up to 30 °C (86 °F) the bearing temperature shall be below 90 °C (194 °F). At higher room temperatures, the bearing temperature shall be below 100 °C (212 °F).

 During pump operation the shut-off element in the inlet line must not be closed.

Any stand-by pumps installed shall be switched on and then immediately off again once a week to keep them operational. Attention shall be paid to the correct functioning of the auxiliary connections.

**Caution** If the flexible coupling elements begin to show signs of wear, they must be replaced in due time. See section "Coupling".

If an external supply of sealing, flushing or lubricating liquid is used, make sure supply pressure is 1.0 to 2.0 bar higher than pressure at the suction nozzle.

### 7.2.2 Shaft Seal Maintenance

For required maintenance work on gland packings please refer to section 8.1. "Shaft seal". Mechanical seals are maintenance-free.

### 7.2.3 Bearing Maintenance

The bearings are maintenance-free and greased for life. No re-lubrication is required.

## 7.3 Dismantling

 Before dismantling, secure the pump so as to make sure it cannot be switched on accidentally. The shut-off elements in the suction and discharge lines must be closed. The pump must have cooled down to ambient temperature, pump pressure must be released and the pump must be drained.

Dismantling and reassembly must always be carried out in accordance with the relevant sectional drawing.

### 7.3.1 Fundamental Instructions and Recommendations

Repair and maintenance work to the pump must only be carried out by specially trained personnel, using original spare parts.

Observe the safety regulations laid down. Any work on the motor shall be governed by the specifications and regulations of the respective motor supplier.

Dismantling and reassembly must always be carried out in accordance with the relevant general drawing. The general drawing and other relevant documents are found in the annex. The dismantling sequence can be derived from the general drawing.

In case of damage you can always contact our nearest customer service centre.

### 7.3.2 Preparations for Dismantling

The pump is designed so that the complete rotor can be removed in the sequence described below without removing the suction or discharge pipe or disturbing the alignment of the pump unit:

- Close the suction and discharge-side gate valves and drain the pump by opening the drain plug (903.01 bottom) and vent plug (903.01 top).
- Remove any pipes between additional equipment and the pump.
- Remove the coupling guard. Decouple pump-side coupling half as described in the appendix.
- Loosen and push back the seal cover (471), if a mechanical seal is fitted.
- Undo the flange screws (901.01 / 901.02) and separate the upper casing half (105.02) from the lower casing half (105.01) with the aid of the forcing screws. Remove with lifting gear. The interior of the pump (impeller with casing wear rings, shaft seal) is now accessible for inspection.
- Remove the screwed connection (901.04) between bearing housing (350.01) and bearing brackets. Also undo the nuts (920.05) and bolts (901.07) which secure the bearing cover (360).
- Press the bearing housing out of the recesses and lift the rotor out of the lower casing half. For further disassembly, place securely in horizontal position.
- Pull off the bearing housing of the fixed bearing (opposite the drive end).
- Undo and remove the keywayed nuts (920.03).
- Remove the deep-groove ball bearing (312) with bush (520) from the shaft.
- Remove the bearing cover (360).
- Remove the V-ring (412.02) from the shaft-protecting sleeve (524.01).
- Pull off the shaft-protecting sleeve (524.01).
- Remove the shaft seal housing (441).
- The impeller (234) is located with a sliding fit on the shaft and can normally be removed easily. In case of difficulty, it can be loosened by gently tapping the hub with a wooden hammer.
- Remove the second shaft protection sleeve (524.01) complete with the shaft seal housing (441), if fitted.
- Remove the coupling half.
- Pull off the bearing housing (350.01).
- Remove the circlip (932) and pull off the deep-groove ball bearing (321).

#### 7.4 Reassembly

Reassembly is effected in reverse order to dismantling. For all work on the pump unit refer to the general drawing, in conjunction with the list of components, for orientation.

The rules of sound engineering practice and also the instructions for removal and installation of shaft seal, bearings, impeller wear rings and casing wear rings (sections 7.5.1 and 7.5.2) must be observed.

The tightening torques indicated for nuts and bolts shall be observed. The table below indicates the tightening torques for threads depending on the materials used.

Property class	(Material)	8.8	10.9	A.-50	A.-70	1.4462
0,2% yield stress		640	900	210		450
$R_{p,0.2}$ in N/mm <sup>2</sup>	1)				250	450
Metric ISO threads		Tightening torque				
coarse-pitch-	fine-pitch-	$M_A$ in Nm				
M4		3,1	4,4	1,0		2,15
M5		6,1	8,7	2,00		4,25
M6		10,4	14,9	3,40		7,30
M8		25,2	36,1	8,30		17,7
M10	M8x1	27,2	39,0	8,90		19,1
	M10x1,25	49,5	71,0	16,2		34,8
M12	M10x1,25	52,5	75,4	17,3		36,9
	M12x1,5	85,2	122,2	28,0		59,9
M16	M12x1,5	89,5	128,5	29,4		62,9
	M12x1,25	93,9	134,7	30,8		66,0
	M16x1,5	211	302,7	69,2		148
M20	M16x1,5	226	324,7	74,3		159
	M20x1,5	412	591,9	135		290
M24	M20x1,5	461	661,0	151		324
	M24x2	710	1019,6	233	276	500
M27	M24x2	780	1118,6	256	305	548
	M27x2	1050	1501,3	343	409	736
M30	M27x2	1130	1627,1	372	443	797
	M30x2	1420	2036,4	466	554	1000
M33	M30x2	1580	2269,9	519	618	1110
	M33x2	1940	2779,4	636	--	1360
M36	M33x2	2130	3062,6	700	--	1500
	M36x3	2480	3552,3	812	--	1740
		2630	3775,4	863	--	1850

1) Nominal values to DIN ISO 898 Part 1, DIN 267 Part 11 and DIN 267 Part 18

It is imperative to lock and seal the screwed connections specially marked in the general drawings.

Symbols for screwed connections to be locked and sealed:



ALTEMP Q NB 50 grease



Sealed with Loctite 574

O-rings and V-rings must be replaced and their seats on the shaft must be cleaned. In addition, all the sealing elements must be fitted into the respective components before installation.

For assembling the rotor, position the pump shaft (211) securely. All fits, threads and sliding fits of the shaft must be cleaned and coated with assembly paste.

Insert the keys required for assembly into the pump shaft (211).

Mount the impeller (234), which has a sliding fit. When fitting the impeller, observe the direction of rotation (see diagram below).

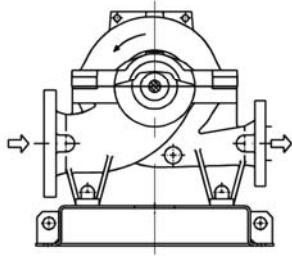

For assembling the casing wear rings (502), observe section 7.5.2 "Replacing the casing wear rings".

Put the casing wear rings onto the running surfaces of the impeller. Ensure that the bezels of the rings are on the outside (towards the bearing). Insert the pins required for fixing the casing wear rings.

The remaining components are fitted first on the movable bearing side (i.e. the drive side) of the pump shaft.

Push the shaft protecting sleeve (524.01) onto the pump shaft (211). Ensure that the groove provided engages in the key of the impeller.

Push the shaft seal housing (441) onto the shaft and install the shaft seal as described in section 8.1, "Gland packing". Slip on V-ring (411.01).

Insert the radial shaft seal ring (421.02) into the bearing cover (360) and push the bearing cover over the shaft.

Heat the deep-groove ball bearing (321) and fit it onto the pump shaft (211). It is essential to avoid one-sided pressure or hammer blows on the outer races. The bearing is secured by the disc (550.01) and the circlip (932).

To fit the shaft protecting sleeve (524.01), shaft seal housing (441), V-ring (411.01) and bearing cover (360) at the non-drive end, proceed as described above for the drive side.

Heat the deep-groove ball bearing (321) and fit it onto the sleeve (520).

Push the sleeve (520) with deep-groove ball bearing (321) onto the pump shaft (211) with key (940.01) inserted.

Tension the rotor parts elastically with keywayed nut (920) and cup spring (950). For this purpose tension the cup spring (950) to blocking point and then undo the keywayed nut (920) again by half a turn (180°).

**Caution** This measure is essential to compensate for differences in thermal expansion between the pump shaft (211) and the components fitted on it.

Rotor assembly is now complete.

Insert the rotor into the pump casing.

Apply Loctite 574 to the casing wear ring surfaces and the sealing surfaces of the casing.

Install the rotor, making sure that the direction of rotation is correct.

Align the rotor and ensure that the fixing pins are correctly seated in the casing.

The pins (561.01) must be positioned as shown in the diagram below.

The bearing housings (350.01) must be fastened to the bearing brackets by means of the screwed connections (901.04), with the sealing cap (580) inserted at the non-drive end. The seating positions are determined by the recesses.

Fit the bearing covers.

To assemble the casing cover, apply Loctite 574 to the casing joint surface of the lower casing half.

Tighten the flange bolts diagonally from the inside towards the outside.

Insert the key for fitting the coupling into the pump shaft (211). When fitting the coupling and accessories, refer to the relevant section of the operating instructions.

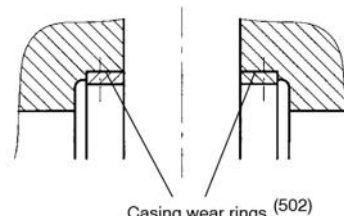

Casing wear rings (502)

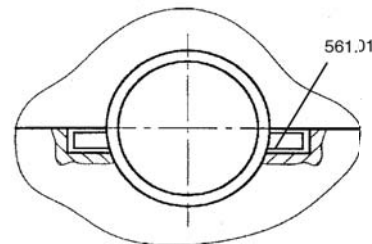

**7.5 Instructions for Replacing Subassemblies**

**7.5.1 Replacing the Shaft Seal**

Proceed as described in section 8.1 and 8.2.

**7.5.2 Replacing Casing Wear Rings and / or Impeller Wear Rings**

The impeller clearance <sup>1)</sup> clearance between impeller 234 and casing wear ring 502 is given in the table below.

For impeller removal proceed as described in section 7.3, "Dismantling".

After dismantling as described in section 7.3.2, the casing wear rings (502) can be removed. When fitting the rings, ensure that their bezels are on the outside (towards the bearing). The pins (561.01) must be positioned as shown in the diagram below.

If the impeller has not been fitted with a wear ring at the factory, and changing the casing wear ring alone does not achieve anything close to the required impeller clearance (the impeller neck is badly worn by clearance flows), the impeller neck must be turned off on a lathe (contact Flo Fab before doing so) and an impeller wear ring fitted in addition (available as spare part). Alternatively, a new impeller can be supplied at short notice.

**Impeller clearances and trim dimensions for impeller wear rings**

No.	Pump size	Shaft unit  D W	Nominal clearance (max. perm.)  $\frac{D_2 - D_1}{2}$  [mm]	Clearance (as-new)		Dimensions of impeller wear ring	
				Min. clearance S min	Max. clearance S max	D 5 [mm]	b [mm]
				[mm]	[mm]		
1		40	0,3	0,15	0,2	134 r6	18
2			0,3	0,15	0,2	134 r6	18
3			0,3	0,15	0,2	134 r6	18
4		40	0,35	0,17	0,2	163 r6	22
5			0,35	0,17	0,2	163 r6	22
6			0,35	0,17	0,2	163 r6	22
7		50	0,35	0,18	0,23	178 r6	22
8			0,35	0,18	0,23	178 r6	22
9			0,35	0,18	0,23	178 r6	22
10			0,35	0,18	0,23	178 r6	22
11		60	0,45	0,22	0,26	210 r6	30
12			0,45	0,22	0,26	210 r6	30
13			0,45	0,22	0,26	210 r6	30
14			0,45	0,22	0,26	210 r6	30
15		70	0,5	0,24	0,28	243 r6	30
16			0,5	0,24	0,28	243 r6	30
17			0,5	0,24	0,28	243 r6	30
18			0,5	0,24	0,28	243 r6	30
19		80	0,5	0,24	0,28	276 r6	30
20			0,5	0,24	0,28	276 r6	30
21			0,5	0,24	0,28	276 r6	30
22		70	0,5	0,24	0,28	259 r6	30
23		80	0,6	0,29	0,35	313 r6	35
24		90	0,6	0,29	0,35	313 r6	35
25			0,6	0,29	0,35	313 r6	35
26		80	0,5	0,24	0,28	294 r6	35
27		90	0,6	0,32	0,37	333 r6	35
28			0,6	0,32	0,37	353 r6	35

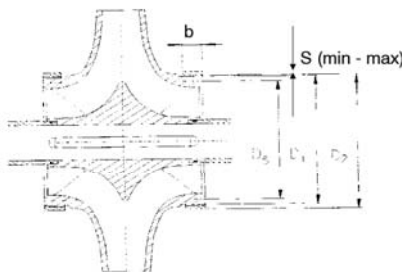

### 7.6 Monitoring schedule

For a detailed description of the pump version, components and accessories supplied by Flo Fab please refer to section 13 of this operating manual.

Component monitored	Action	Value required
Mechanical seal (if applicable)	Check for leakage (daily)	see section 8.2 and *
Suction side measuring instrument, ps (if applicable)	Check pressure (daily)	*
Discharge side measuring instrument, pd (if applicable)	Check pressure (daily)	*
Thermometer (suction / discharge nozzle) (if applicable)	Check temperature (weekly)	*
Flushing line sight glass (if applicable)	Check flushing water flow (weekly)	Water flows
Vibration measurement (if applicable)	Check weekly	*
Bearing temperature (if applicable)	Check weekly	Section 7.2
Coupling	Check weekly	Annex from p. 47, detailed manufacturer information
Drive (if applicable)	See manufacturer's documentation	Ensure contact-free installation
Coupling guard	Check monthly	No contact permitted
Earthing connection	Check monthly	Connection must be fitted and marked.

\* see list of measuring points (if applicable) in section 13, Annex.

8.1 Mechanical Seal Variants (Mech. Seal Size / Pump Size Combinations)

No.	Pump size	Shaft unit	Nom. mech. seal size	Mechanical seal variants	
				Non-balanced	Balanced
		$d_w$	d		
1		40	50	M 7 N 4 / 50	HJ 92 N / 50
2					
3					
4					
5					
6					
7		50	60	M 7 N 4 / 60	HJ 92 N / 60
8					
9					
10					
11					
12					
13		60	70	M 7 N 4 / 70	HJ 92 N / 70
14					
15					
16					
17		70	80	M 7 N 4 / 80	HJ 92 N / 80
18					
19					
20		80	90	M 7 N 4 / 90	HJ 92 N / 90
21					
22		70	80	M 7 N 4 / 80	HJ 92 N / 80
23		80	90	M 7 N 4 / 90	HJ 92 N / 90
24		90	110	M 74 N / 110	H 75 N / 110
25					
26		80	90	M 7 N 4 / 90	HJ 92 N / 90
27		90	110	M 74 N / 110	H 75 N / 110
28					



**8.2.1 Mechanical Seal "Type H7N4"**  
(Shaft unit  $d_w$  40 to 80 mm)

The mechanical seal type H 7 N 4 used is a single-acting, bi-rotational, non-balanced seal which does not require circulation pipework in cold water applications, due to the pump design.

**Caution** Dry-running of the seal must be avoided at all costs!

**Installation**

For the installation of the total seal assembly (mechanical seal, seal housing) see operating instructions for the pump.

The shaft protection sleeves and also the surfaces of the casing are subjected to accurate finishing processes with regard to the O-ring seats, in order to achieve a complete and reliable seal. Care must be taken during installation to keep these parts absolutely clean, to avoid the surfaces from being damaged and prevent entry of foreign particles.

The seat ring (8) together with the relevant O-ring (9), is fitted into the seal cover (see general drawing). The O-ring can be lubricated for easy sliding movement. Special attention must be given to ensure that pressure is applied evenly. The contact surfaces are generally fitted dry.

In mechanical seals of the M7N4 design, the rotating assembly is supplied as one unit, consisting of a housing and pin ( 1 + 5), fitted spring loaded ring (6), O-ring (2), spring (3), thrust plate (4) and grub screws (7). The grub screws (7) must be loosened so far as to prevent them from protruding from the housing (1) at the inner diameter. The O-ring (2) can be slightly lubricated to facilitate assembly.

The complete rotating assembly is pushed onto the shaft protection sleeve in compliance with the installation dimensions which are given in the mech. seal drawing, or until it reaches the stop on the shaft protection sleeve. Finally the grub screws are tightened and secured with LOCTITE.

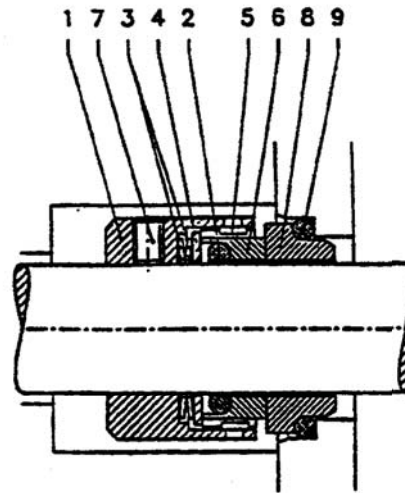

Item	Description	Material	No. of items
1	Housing	Cr-Ni-Mo-steel	1
2	O-ring	Viton	1
3	Spring	Cr-Ni-Mo-steel	1
4	Thrust plate	Cr-Ni-Mo-steel	1
5	Pin	Cr-Ni-Mo-steel	2
6	Spring-loaded ring	Si-SiC	1
7	Grub screw	Cr-Ni-Mo-steel	2
8	Seat ring	Si-SiC	1
9	O-ring	Viton	1

**Special instructions for mechanical seal assembly**

- The contact faces must only be cleaned with propyl alcohol and paper tissue.
  - Never use cleaning rags or cloth.
  - Clean carefully to remove any smears.
- Do not touch the contact faces with bare fingers.
- Never use force during mechanical seal assembly.
- Never put the spring-loaded ring and the seat ring face down on the contact faces without the protective wrapping.
- Cover the contact face with a cardboard washer and press the seat ring into its position slowly and evenly, lubricating it with a generous amount of water or alcohol. Use a spacer sleeve, if necessary. Verify that the seat ring position is normal to the shaft axis.
- In the mechanical seal area, the shaft shall be slightly lubricated with water, alcohol or silicone grease. Sealing elements made of **EP rubber must never come into contact with mineral oil base lubricants** (swelling, possibly decomposition).

### Commissioning

Flood the pump and the seal chamber with the medium to be handled and vent carefully. The seal is operational now.

On **single-acting** mechanical seals, the **pressure in the seal chamber** of the pump (stuffing box) must always **exceed ambient pressure**, to prevent any **air intake** at the seal faces, which would result in dry running and thus **failure of the mechanical seal**.

In **all operating conditions**, the product to be sealed off must be available **in liquid state** at the mechanical seal, particularly during pump start-up and shutdown. This must be ensured by appropriate facilities on the pump (e.g. heating).

Should the mechanical seal **fail**, the liquid to be sealed off may **spurt out**. Take suitable precautions to prevent hazards to persons and the environment, e.g. install splash guards, wear safety goggles, etc. **Proper disposal** of leakage shall be arranged for and supervised **by the operator**.

### Maintenance

Mechanical seals **operated in compliance with the manual** are **maintenance-free** in their entire service life.

The mechanical seal should be inspected in accordance with the plant inspection schedule.

During planned plant outage periods the spring-loaded rings and the seat rings should be checked for visible damage in installed condition.

If the mechanical seal is inspected during plant outage, the contact faces should be re-worked.

### Faults

Determine and document the nature of the fault.

In the event of a fault as evidenced by excessive leakage, observe the tendency of the leakage amount. Changes in operating conditions must be documented. If an excessive temperature rise is detected, the mechanical seal must be shut down for safety reasons.

During the warranty period the mechanical seal shall only be removed and dismantled with the manufacturer's approval or under instructions of the mechanical seal manufacturer's service engineers.

If the fault cannot be remedied by the operator or if the cause is unclear, please contact the Flo Fab service center.

### Dismantling

For dismantling of the mechanical seal assembly please refer to section 7.3 "Dismantling". Grub screws (7) and joint rings (2+9) shall be replaced whenever the mechanical seal has been dismantled!

### Repair

If the seal needs to be **repaired**, always **return the complete seal** to the manufacturer. The manufacturer will know best which parts can be re-worked and which parts have to be replaced to ensure an optimum sealing effect.

If repair on the spot is necessary, it should be carried out in a clean workshop preferably by Flo Fab or skilled operator staff. Spring-loaded rings, seat rings, all elastomer materials

and springs should be replaced in any case.

Make sure to **comply with the instructions for handling hazardous substances and the applicable accident prevention regulations** when repairing, dismantling and cleaning used mechanical seals. If you have any queries in this context **please inform yourself before commencing** any repair work.

### Spare parts

Only **original spare parts** shall be used. **Non-compliance** with this requirement entails the risk of **seal malfunctions** which may jeopardize the safety of personnel and the environment.

It will also lead to **forfeiture of all warranty claims**.

**8.2.2 Mechanical Seal - "Type M74N "**  
(Shaft unit  $d_w = 90$  mm)

**This mechanical seal type is a single-acting, bi-rotational, non-balanced mechanical seal with multiple spring arrangement.**

**Caution** It is imperative to avoid dry running of the mechanical seal!

**Special instructions for mechanical seal installation**

• **Application limits**

Pressure to be sealed off, p max.	25 bar
Product temperature, t	-40...220 °C
Sliding velocity, vg	20 m/s

• **Safety**

Any **work on the mechanical seal** shall only be performed after the **pump has stopped** and pump pressure has been released.

In addition to the safety instructions contained in this manual, the general **health and accident prevention regulations** shall be observed.

**Preparations for installation**

Check pump components for:

- **chamfered edges** (sliding cones 2 mm/ 30° or to DIN 24960).
- **radiused transitions**
- **locating surfaces**, surfaces for O-rings: fine finished Rz 10 (DIN 4768)
- **Shaft surface** in the area of the dynamically loaded joint ring: roughness depth  $R_{max} 5 \mu m$ .

The shaft must be provided with the requisite recesses for the housing screws of the mechanical seal.

Check pump for:

- damage at the mating surfaces with the mechanical seal
- connecting dimensions, rectangularity and concentricity to the shaft axis

**Installation**

For the installation of the total seal assembly (mechanical seal, seal housing) see operating instructions for the pump.

The shaft protection sleeves and also the surfaces of the casing are subjected to accurate finishing processes with regard to the O-ring seats, in order to achieve a complete and reliable seal. Care must be taken during installation to keep these parts absolutely clean, to avoid the surfaces from being damaged and prevent entry of foreign particles.

The seat ring (8) together with the relevant O-ring (9), is fitted into the seal cover (see general drawing). The O-ring can be lubricated for easy sliding movement. Special attention must be given to ensure that pressure is applied evenly. The contact surfaces are generally fitted dry.

In mechanical seals of the **M 74 N** design, the rotating assembly is supplied as one unit, consisting of a housing and pin (1 + 5), fitted spring loaded ring (6), O-ring (2), spring (3), thrust plate (4) and grub screws (7). The grub screws (7) must be loosened so far as to prevent them from protruding from the housing (1) at the inner diameter. The O-ring (2) can be slightly lubricated to facilitate assembly.

The complete rotating assembly is pushed onto the shaft protection sleeve in compliance with the installation dimensions which are given in the mech. seal drawing, or until it reaches the stop on the shaft protection sleeve. Finally the grub screws are tightened and secured with LOCTITE.

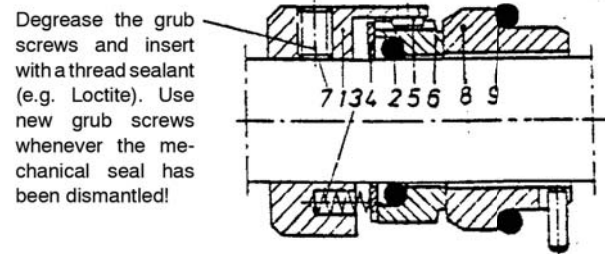

Item	Description	Material	No. of items
1	Housing	Cr-Ni-Mo-steel	1
2	O-ring	Compat. elastomers	1
3	Spring	Cr-Ni-Mo-steel	1
4	Thrust plate	Cr-Ni-Mo-steel	1
5	Pin	Cr-Ni-Mo-steel	2
6	Rotating ring	Buka, Buke, Bume	1
7	Grub screw	Cr-Ni-Mo-steel	2
8	Seat ring	Buke, Buko, Buka	1
9	O-ring	Compat. elastomers	1

- Apply a thin coat of grease to the shaft in the mechanical seal area.

Sealing elements made of **EP rubber must never come into contact with mineral oil base lubricants** (swelling, possibly decomposition).

- Unwrap the mechanical seal and inspect for damage to the spring-loaded ring and the seat ring, the O-rings and the mating surfaces.

Never put the spring-loaded ring and the seat ring face down on the contact faces without the protective wrapping.

- Thoroughly clean all components with alcohol and cellulose tissue.

### Installation

**Never use force** during mechanical seal installation.

- Slip the degreased O-ring onto the seat ring.
- Cover the contact face with a cardboard washer.
- Push the seat ring slowly and evenly into its seat. Use a spacer sleeve, if necessary. Lubricate with a generous amount of water or alcohol.
- Verify that the seat ring position is normal to the shaft axis.
- Push the rotating assembly with the **degreased** joint rings onto the shaft. Thread in the **degreased** grub screws with 1 drop of thread sealant each (e.g. Loctite No. 243) and position the mechanical seal by tightening the grub screws. The installation dimensions given in the drawing must be adhered to.
- The contact faces must only be cleaned with propyl alcohol and paper tissue (no cleaning rags or cloth). Clean carefully to remove any smears. Do not touch the contact faces with bare fingers afterwards.

The contact faces must not be lubricated; they must be clean and dry.

- Assemble the seal cover with the installed seat ring.

### Commissioning

Flood the pump and the seal chamber with the medium to be handled and vent carefully. The seal is operational now.

### Reliable seal operation

On **single-acting** mechanical seals, the **pressure in the seal chamber** of the pump (stuffing box) must always **exceed ambient pressure**, to prevent any **air intake** at the seal faces, which would result in **dry running** and thus **failure of the mechanical seal**.

**In all operating conditions**, the product to be sealed off must be available **in liquid state** at the mechanical seal, particularly during pump start-up and shutdown. This must be ensured by appropriate facilities on the pump (e.g. heating).

If the operating conditions indicated are observed and the instructions given in this operating manual are complied with, the mechanical seal can be expected to give trouble-free operation.

 Should the mechanical seal **fail**, the liquid to be sealed off may **spurt out**. Take **suitable precautions** to prevent hazards to persons and the environment, e.g. install splash guards, wear safety goggles, etc. **Proper disposal** of leakage shall be arranged for and supervised **by the operator**.

### Faults

Determine and document the nature of the fault.

In the event of a fault as evidenced by excessive leakage, observe the tendency of the leakage amount. Changes in operating conditions must be documented. If an excessive temperature rise is detected, the mechanical seal must be shut down for safety reasons.

A continuous flow of leakage indicates a fault.

During the warranty period the mechanical seal shall only be removed and dismantled with the manufacturer's approval or under instructions of the mechanical seal manufacturer's service engineers.

If the **fault** cannot be remedied by the operator or if the cause is unclear, please contact the Flo Fab service centre.

### Maintenance

Mechanical seals operated in compliance with the manual are maintenance-free; however, wear parts will have to be replaced as required.

The mechanical seal should be inspected in accordance with the plant inspection schedule. We recommend to have the mechanical seal inspected by Flo Fab service centre.





If the mechanical seal is inspected during plant outage, the contact faces should be re-worked and all elastomer seals and springs should be replaced.

### Repair

If the seal needs to be **repaired**, always **return the complete seal** to the manufacturer. The manufacturer will know best which parts can be re-worked and which parts have to be replaced to ensure an optimum sealing effect.

**If repair on the spot is absolutely necessary** (e.g. no spare seal available, long transport distances, problems with customs procedures), **skilled** operator staff may carry out the repair work in a clean workshop to the directions of Flo Fab service centres.

### Mechanical seal removal

-  Shut down the pump in accordance with the operating manual, allow to cool down and release pump pressure.
-  There must be no **pumped product at the mechanical seal** → The pump must be drained.
-  **Secure the pump** to prevent inadvertent start-up.
-  **Follow the safety instructions** (safety data sheets)!

Make sure to **comply with the applicable accident prevention regulations** when removing a mechanical seal. Also observe the **instructions for handling hazardous substances** if the mechanical seal has already been in operation. If you have any **queries** about the applicable regulations **please inform yourself before commencing** any repair work.

**Any work** on the mechanical seal is only permitted with the **pump shut down** and **pump pressure released**.

Removal of the mechanical seal shall be performed analogously with mechanical seal installation, but in reverse order.

### Removing the subassembly

See section 7.3.

- Grub screw (7) und Dichtringe (2+9) nach jeder Demontage erneuern.

### Spare parts

Only **genuine spare parts** shall be used. **Non-compliance** with this requirement entails the risk of **seal malfunctions** which may jeopardize the safety of personnel and the environment.

It will also lead to **forfeiture of all warranty claims**. To keep a complete spare seal on stock.

### 8.2.3 Mechanical Seal "Type HJ92 N" (Shaft unit $d_w = 40$ to 80 mm)

# OPERATING MANUAL

## MECHANICAL SEAL (MS)

### HJ92N

PLEASE READ this manual carefully and OBSERVE the information contained as to:

- Safety
- Storage
- Installation
- Start up
- Maintenance
- Repair

#### ■ SAFETY

Any person in the operator's plant who is involved in the installation, removal, operation, commissioning and maintenance of the mechanical seal must have read and thoroughly understood these operating instructions, particularly the safety instructions contained therein. It is advisable for the operator to have this confirmed.

The mechanical seal is a precision product (ISO 9001) and safe to operate. However, it may constitute a hazard if it is not used in accordance with its designated use, or if operated improperly by unskilled personnel.

The operator has to determine the consequences of any mechanical seal failure and decide whether safety precautions need to be taken to protect personnel or the environment.

The pump shall be installed in such a way that any fluid spurting out cannot cause personal injury and that leakage can be properly disposed of.

Any operating mode liable to impair the safe and reliable function of the mechanical seal is not permitted.  
Mechanical seals shall only be installed, operated, removed or repaired by authorized, qualified and appropriately instructed personnel.

Any work on the mechanical seal shall only be performed with the pump shut down and the pump pressure released.  
Staff responsibilities for the work involved must be clearly defined and complied with, to prevent unclear competencies with regard to safety aspects.

In addition to the instructions contained in this manual, the general occupational health and safety regulations must be adhered to.

Unauthorized modifications and alterations liable to jeopardize the safe operation of the mechanical seal are not permitted.

#### ■ DECLARATION

within the meaning of EC Directive "Machinery" 98/37/EC.

A mechanical seal does not function independently. It is intended to be incorporated into or assembled with machinery.

#### ■ OPERATING LIMITS

Shaft diameter dw:	18 to 100 mm
Press. to be sealed off p max.:	25 bar *)
Fluid temperature t:	-40 to 220 °C
Sliding velocity vg:	20 m/s

\*) depending on the seal face materials

The mechanical seal shall not be operated at several application limits at the same time.

Higher loads (pressure, temperature, speed) may lead to increased wear and damage the contact faces or the elastomer elements.

Such operating conditions would shorten the useful life of the seal but also entail the risk of sudden seal failure with hazards to personnel and the environment.

#### ■ OPERATING DATA

The operating data for the application in question, such as fluid to be sealed off, operating pressure, operating temperature, rotational speed, etc., are indicated on the respective pump data sheets.

#### ■ DESIGNATED USE

Any operation outside the operating conditions stated in the "Operating Limits" section is deemed to be non-conforming with the designated use.

To ensure safe operation of the mechanical seal, check with the seal manufacturer before using the seal for other operating conditions or in a different location of operation.

#### ■ MATERIALS

Materials as per drawing and/or order.

#### ■ DRAWINGS

General assembly drawing of pump.

The applicable design is shown on the general pump drawing in the original scale and latest revision, see section 9 of the pump's operating manual, which shall be used in conjunction with this document.

#### ■ SPECIFICATION

- Single mechanical seal
- Balanced
- Bi-rotational
- Connecting dimensions to DIN 24960 KB
- Installation dimensions I<sub>1K</sub>

Due to their protected spring (1.5), mechanical seals of this type are particularly suitable for fluids containing solids and/or highly viscous fluids, for ex. in sugar, paper or waste water applications. The seal design is rugged and reliable. The spring neither clogs nor sticks. Max. axial end play between shaft and housing: 0.5 mm in any direction.

For operation at negative pressures (down to -0.2 bar), no seat lock is required for the seat ring (2).

Torque transmission between the shaft and the seal is normally effected by grub screws(1.6); or by special drive elements (1.2) on individual models.

## ■ LIQUID SUPPLY TO MECHANICAL SEAL

To ensure trouble-free operation of the mechanical seal, a suitable circulation process has been selected on the pump, see section 9 of the pump's operating manual. This process avoids product deposits in the seal chamber.

## ■ EMISSIONS

Mechanical seals are dynamic seals which for physical and technical reasons cannot be completely leak-free. The amount of leakage largely depends on the seal selection, production tolerances, operating conditions, smooth running of the machine, etc. Compared with other dynamic sealing systems, however, mechanical seals have little leakage.

Should the mechanical seal fail, the hot liquid or steam to be sealed off may spurt out. Splash guards fitted on the machine, safety goggles worn by the operating staff, etc. may prevent hazards to persons. The operator/owner is responsible for the proper disposal of leakage, in order to prevent hazards to the environment.

Leakage may be liquid or gaseous, its aggressiveness corresponding to that of the fluid to be sealed off.

Any mechanical seal leakage must be drained off in a controlled way and safely disposed of.

☞ Components which may come into contact with the seal leakage shall either be corrosion resistant or must be adequately protected.

## ■ STORAGE

Unless otherwise agreed in the contract, mechanical seals are delivered in standard packaging suitable for dry transport by truck, train or plane. The symbols or handling instructions given on the packaging must be adhered to.

### For incoming goods inspection:

- Check packaging for external damage.
- Carefully open packaging, making sure not to damage or lose any components packed separately.
- Check consignment for completeness (delivery note). The supplier shall be notified immediately of any damaged goods or missing parts.

The instructions given below shall apply both to mechanical seals delivered and stored in their undamaged, original packaging, and to mechanical seals already installed in a pump, which have not been in operation yet.

The mechanical seals need not be preserved.

- Do not apply anti-corrosives.
  - ◆ Risk of deposits and possible chemical attacks on elastomer secondary seals.

When applying preservatives to entire systems where mechanical seals are installed please check the following:

- Verify the compatibility of the preservatives chosen with the materials of construction and the elastomer components of the mechanical seal.
- Verify that mechanical seal movement is not restricted by resin deposits or sticking.

During storage, seal face materials and elastomers will undergo material specific time dependent changes (distortion, ageing), which can impair the perfect function of the mechanical seal. The specified storage period must therefore be complied with.

The manufacturer cannot be held responsible for damage resulting from improper storage.

The room where mechanical seals are kept must be dust-free and moderately ventilated, with an even temperature. We recommend: relative humidity below 65%, temperature between 15 °C and 25 °C.

The mechanical seal shall be protected from:

- direct heat from sun, heating
- ozone and ultraviolet light from halogen lamps, fluorescent lamps, sunlight, arc welding
- ◆ danger of embrittlement of elastomer materials

The seals shall be stored in their original packaging on a level surface.

### **The mechanical seal needs to be checked:**

- after a storage period of approx. 2-3 years
- if the packaging has been damaged
- after a shock load (e.g. if the mechanical seal package has been dropped)
- ◆ at the manufacturer's workshop or nearest service centre.

## ■ BEFORE INSTALLATION

### Checks to be carried out on the pump components:

Shaft surface in the area of the dynamically loaded seal ring: roughness depth  $R_{max}$  5  $\mu$ m.

### Checks to be carried out on the pump:

- Check contact surfaces between the pump and the mechanical seal for damage.
- Connecting dimensions, squareness and concentricity to shaft.
- Shaft run-out as per DIN ISO 5199: between 50  $\mu$ m and 100  $\mu$ m, depending on the diameter.
- Apply a thin coat of suitable grease to the shaft in the mech.seal area.
- ◆ Never use mineral oil base lubricants on sealing elements made of ethylene propylene rubber (swelling possibly decomposition).
- ◆ Grease recommended for elastomer sealing elements (O-rings, etc.): type "TURMOPOLGREASE SH2", producer: Lubricant Consult (LUBCON).

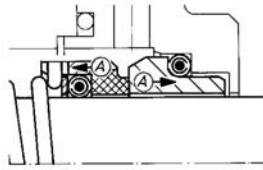

- ◆ Double PTFE encapsulated O-rings must be fitted so that the joint of the outer sheath points in opposite direction to the mounting direction, so that the friction force generated when sliding on the O-ring closes the joint. Kinks in the foil will result in leakage.

### ■ INSTALLATION TOOLS / EQUIPMENT

- Propyl alcohol + paper tissue (no cleaning rags)
- Lubricating grease for elastomer seals: type "TURMOPOLGREASE SH2", producer: Lubricant Consult (LUBCON)
- Thread-locking compound, e.g. type "LoctiteR Nr. 243", producer: Loctite Corporation
- O-ring extractor
- Set of hex. keys (WAF 2 mm - 6 mm)
- Cardboard washers to protect the contact faces during installation
- Manual screw press (compulsory from DN 80 mm).

### ■ INSTALLATION

Refer to the general pump assembly drawing when installing the mechanical seal.

Mechanical seals are precision-machined machinery components which have been inspected several times. They must be installed with due care and in compliance with certain procedures, particularly regarding the contact faces and elastomer seals.

Utmost cleanliness must be ensured in the immediate vicinity of the location where a mechanical seal is to be installed.

Never use force when installing a mechanical seal.

- Unpack the seal and inspect the spring-loaded ring, seat ring, O-rings and contact faces for damage.
  - ◆ Never place the spring-loaded ring and the seat ring on the table facing down without protecting the contact faces.
- Thoroughly clean all parts with alcohol and paper tissue.

The sequence of operations required to install the mechanical seal in the machine depends on the design of the machine in question, which is described in the pump's operating manual.

Unless otherwise stated, apply a very thin coat of grease to O-rings which will slide into or onto other components during mechanical seal installation.

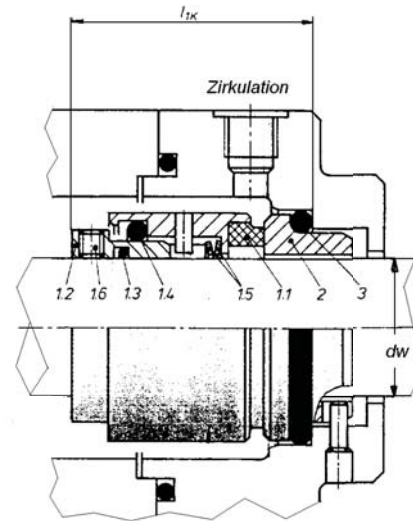

### Possible installation sequence:

- Slide the degreased O-ring onto the seat ring.
- Cover the contact face of the seat ring with a cardboard washer. Generously lubricate the seat ring with water or alcohol and press it slowly and evenly into its seat. Use a spacer, if necessary. Check squareness of seat ring to the shaft axis.
- Apply a thin coat of grease to the shaft protecting sleeve in the mechanical seal area.
  - ◆ Never use mineral oil base lubricants on sealing elements made of ethylene propylene rubber (swelling, possibly decomposition).
- Slide the rotating seal assembly with greased O-rings onto the shaft protecting sleeve.
- Fit the degreased grub screws, having applied one drop of thread-locking compound (e.g. Loctite R No. 243) to each screw.
- Tighten the grub screws to lock the torque-transmitting sleeve into place.
- Clean the contact faces with propyl alcohol and paper tissue (**no cloth, no cleaning rags!**) to remove any smears. Do not touch the contact faces with bare fingers after that.
  - ◆ Do not apply lubricants to the contact faces. The contact faces must be installed in clean and dry condition.
- Fit the seal cover with pre-assembled seat ring.

### ■ COMMISSIONING

Prime the pump and the seal chamber with the fluid handled and vent thoroughly. The seal is now ready for operation.

### ■ SAFE OPERATION

For single mechanical seals, the pressure in the seal chamber of the pump must always exceed ambient pressure, to prevent any air intake at the seal faces, which would result in dry running and thus failure of the mechanical seal.

In all operating conditions, the product to be sealed off must be available in liquid state at the mechanical seal, particularly during pump start-up and shutdown.

If the operating conditions indicated are observed and the instructions given in this operating manual are complied with, the mechanical seal can be expected to give trouble-free operation.

### ■ HEALTH AND SAFETY

Mechanical seals are often used for sealing off hazardous substances (chemicals, pharmaceuticals, etc.). The applicable instructions and regulations for handling hazardous materials must absolutely be adhered to.



Should the mechanical seal fail, the hot liquid or steam to be sealed off may spurt out. Splash guards fitted on the machine, safety goggles worn by the operating staff, etc. may prevent hazards to persons. The operator/owner is responsible for the proper disposal of leakage, in order to prevent hazards to the environment.

## ■ FAULTS/MALFUNCTIONS

Determine and document the nature of the fault/malfunction. In the event of a fault as evidenced by excessive leakage, observe the tendency of the leakage amount. Changes in operating conditions must be documented. If an excessive temperature rise is detected, the mechanical seal must be shut down for safety reasons.

A continuous flow of leakage indicates a fault/malfunction at the mechanical seal.

During the warranty period the mechanical seal shall only be removed and dismantled with the manufacturer's approval or in the presence of his representative.

If the fault/malfunction cannot be remedied by the operator or if the cause is unclear, please contact your responsible Flo Fab service centre.

## ■ SERVICING / MAINTENANCE

Mechanical seals operated in compliance with manual are maintenance-free. Wear parts, however, must be replaced as required.

The mechanical seal shall be inspected in accordance with the plant inspection schedule. We recommend to have the mechanical seal inspected by competent Flo Fab service staff.

If the mechanical seal is removed during plant inspection, the contact faces shall be re-worked and all elastomer seals and springs shall be replaced.

## ■ REPAIR

If the seal needs to be repaired, always return the complete seal to the manufacturer. The manufacturer's service personnel will know best which parts can be re-worked and which parts have to be replaced to ensure an optimum sealing effect.

If repair on the spot is absolutely necessary (e.g. no spare seal available, long transport distances, problems with customs procedures), skilled operator staff may carry out the repair work in a clean workshop to the directions of the seal manufacturer's fitters.

## ■ SPARE PARTS

Use only genuine spare parts, to prevent

- the risk of mechanical seal malfunction, involving hazards to persons and the environment.
- forfeiture of any and all warranty claims.

To ensure quick mechanical seal replacement, we recommend to stock a complete spare seal.

## ■ REMOVING THE SEAL FROM THE PUMP



- Shut down the pump, allow to cool down and release pressure as per operating instructions
- No product should contact the mechanical seal/ Drain the pump, if necessary!
- Secure the pump against inadvertent start-up!
- Follow the safety instructions (safety data sheets)!

When removing the mechanical seal make sure to observe the applicable health and safety regulations, as well as the regulations for handling hazardous substances, if the mechanical seal has already been in operation. If in doubt, the necessary information has to be obtained before starting repair work.

Any work on the mechanical seal shall only be performed with the pump shut down and the pump pressure released.

The sequence of operations required to remove the mechanical seal from the pump depends on the design of the pump in question, which is described in the pump's operating manual.

Removal of the mechanical seal shall be effected in analogy with, but in reverse order to, installation.

## ■ CUSTOMER SERVICE

Services provided by the seal manufacturer range from planning advice to product support after commissioning.

For this purpose, the manufacturer has established a worldwide network of subsidiaries abroad, partner companies, sales offices and service centres, to handle any problems.

## ■ PURCHASE ORDERS

For enquiries and purchase orders, the following details are required:

- Flo Fab order No.
- No. of general pump assembly drawing
- Part item No., description, material, quantity as per drawing.

## ■ DISPOSAL

Usually, mechanical seals can easily be disposed of after a thorough cleaning.

- Metal parts (steel, stainless steel, non-ferrous metals), shall be sorted and disposed of in the appropriate waste metal collection facility.
- Plastics (elastomers, PTFE) are special waste. After sorting, some of them can be recycled.
  - ◆ **CAUTION!** Material containing fluorine must not be incinerated.
- Ceramic contact face materials (carbon, ceramics, carbide) can be separated from their carrier materials and - being physiologically harmless - disposed of as residual waste.

**We reserve the right to technical modifications designed to improve the product, even if they are not mentioned in this manual yet.**

# OPERATING MANUAL

## BURGMANN MECHANICAL (M.S.)

### H75N

PLEASE READ this manual carefully and **OBSERVE** the information contained as to:

■ Safety ■ Storage ■ Installation ■ Start up ■ Maintenance ■ Repair

#### ■ SAFETY

Any person in the operator's plant who is involved in the installation, removal, operation, commissioning and maintenance of the mechanical seal must have read and thoroughly understood these operating instructions, particularly the safety instructions contained therein. It is advisable for the operator to have this confirmed.

The mechanical seal is a precision product (ISO 9001) and safe to operate. However, they may constitute a hazard if they are not used in accordance with their designated use, or if operated improperly by unskilled personnel.

The operator has to determine the consequences of any mechanical seal failure and decide whether safety precautions need to be taken to protect personnel or the environment.

The pump shall be installed in such a way that any fluid spurting out cannot cause personal injury and that leakage can be properly disposed of.

Any operating mode liable to impair the safe and reliable function of the mechanical seal is not permitted.

Mechanical seals shall only be installed, operated, removed or repaired by authorized, qualified and appropriately instructed personnel.

Any work on the mechanical seal shall only be performed with the pump shut down and the pump pressure released.

Staff responsibilities for the work involved must be clearly defined and complied with, to prevent unclear competencies with regard to safety aspects..

In addition to the instructions contained in this manual, the general occupational health and safety regulations must be adhered to.

Unauthorized modifications and alterations liable to jeopardize the safe operation of the mechanical seal are not permitted.

#### ■ DECLARATION

within the meaning of EC Directive "Machinery" 98/37/EC.

A mechanical seal does not function independently. It is intended to be incorporated into or assembled with machinery.

#### ■ OPERATING LIMITS

Shaft diameter dw:	28 to 100 mm
Press. to be sealed off p max.:	40 bar *)
Fluid temperature t:	-40 to 220 °C
Sliding velocity vg:	20 m/s

\*) depending on the seal face materials

The mechanical seal shall not be operated at several application limits at the same time.

Higher loads (pressure, temperature, speed) may lead to increased wear and damage the contact faces or the elastomer elements.

Such operating conditions would shorten the useful life of the seal but also entail the risk of sudden seal failure with hazards to personnel and the environment.

#### ■ SPECIFICATION

The operating data for the application in question, such as fluid to be sealed off, operating pressure, operating temperature, rotational speed, etc., are indicated on the respective pump data sheets.

#### ■ DESIGNATED USE

Any operation outside the operating conditions stated in the "Operating Limits" section is deemed to be non-conforming with the designated use.

To ensure safe operation of the mechanical seal, check with the seal manufacturer before using the seal for other operating conditions or in a different location of operation.

#### ■ MATERIALS

Materials as per drawing and/or order.

#### ■ DRAWINGS

General assembly drawing of pump.

The applicable design is shown on the general pump drawing in the original scale and latest revision, see section 9 of the pump's operating manual, which shall be used in conjunction with this document.

#### ■ SPECIFICATION

- Single mechanical seal
- Balanced
- Bi-rotational
- Rotating spring-loaded ring
- Stationary seat ring

- Multiple springs in guide sleeves
- axial mobility/play up to  $dw\ 55 = \pm 2\ \text{mm}$ , and  $\pm 3\ \text{mm}$
- Torque transmission by grub screws
- Connecting dimensions to DIN 24960 KB
- Installation dimensions  $I_{1K}$

## ■ LIQUID SUPPLY TO MECHANICAL SEAL

To ensure trouble-free operation of the mechanical seal, a suitable circulation process has been selected on the pump, see section 9 of the pump's operating manual. This process avoids product deposits in the seal chamber.

## ■ EMISSIONS

Mechanical seals are dynamic seals which for physical and technical reasons cannot be completely leak-free. The amount of leakage largely depends on the seal selection, production tolerances, operating conditions, smooth running of the machine, etc. Compared with other dynamic sealing systems, however, mechanical seals have little leakage.

Leakage may be liquid or gaseous, its aggressiveness corresponding to that of the fluid to be sealed off.

Any mechanical seal leakage must be drained off in a controlled way and safely disposed of.

☞ Components which may come into contact with the seal leakage shall either be corrosion resistant or must be adequately protected.

## ■ STORAGE

Unless otherwise agreed in the contract, mechanical seals are delivered in standard packaging suitable for dry transport by truck, train or plane. The symbols or handling instructions given on the packaging must be adhered to.

For incoming goods inspection:

- Check packaging for external damage.
- Carefully open packaging, making sure not to damage or lose any components packed separately.
- Check consignment for completeness (delivery note). The supplier shall be notified immediately of any damaged goods or missing parts.

The instructions given below shall apply both to mechanical seals delivered and stored in their undamaged, original packaging, and to mechanical seals already installed in a pump, which have not been in operation yet.

The mechanical seals need not be preserved.

- Do not apply anti-corrosives.
  - ◆ Risk of deposits and possibly chemical attack of the elastomer secondary sealing elements.

When applying preservatives to entire systems where mechanical seals are installed please check the following:

- Verify the compatibility of the preservatives chosen with the materials of construction and the elastomer components of the mechanical seal.
- Verify that mechanical seal movement is not restricted by resin deposits or sticking.

During storage, seal face materials and elastomers will undergo material specific time dependent changes (distortion, ageing), which can impair the perfect function of the mechanical seal. The specified storage period must therefore be complied with.

The manufacturer cannot be held responsible for damage resulting from improper storage.

The room where mechanical seals are kept must be dust-free and moderately ventilated, with an even temperature. We recommend: relative humidity below 65%, temperature between 15 °C and 25 °C.

The mechanical seal shall be protected from:

- direct heat from sun, heating
  - ozone and ultraviolet light from halogen lamps, fluorescent lamps, sunlight, arc welding
  - ◆ danger of embrittlement of elastomer materials.
- The seals shall be stored in their original packaging on a level surface.

**The mechanical seal needs to be checked:**

- after a storage period of approx. 2-3 years
- if the packaging has been damaged
- after a shock load (e.g. if the mechanical seal package has been dropped)
- ◆ at the manufacturer's workshop or nearest service centre.

## ■ BEFORE INSTALLATION

Checks to be carried out on the pump components:

Shaft surface in the area of the dynamically loaded seal ring: roughness depth  $R_{\text{max}}\ 5\ \mu\text{m}$ .

Checks to be carried out on the pump:

- Check contact surfaces between the pump and the mechanical seal for damage.
- Connecting dimensions, squareness and concentricity to shaft
- Shaft run-out as per DIN ISO 5199: between 50  $\mu\text{m}$  and 100  $\mu\text{m}$ , depending on the diameter.
- Apply a thin coat of a suitable grease to the shaft in the mech. seal area.
- ◆ Never use mineral oil base lubricants on sealing elements made of ethylene propylene rubber (swelling, possibly decomposition).
- ◆ Grease recommended for elastomer sealing elements (O-rings, etc.): type "TURMOPOLGREASE SH2", producer: Lubricant Consult (LUBCON).

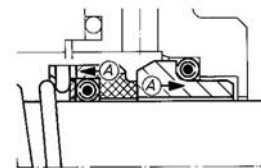

- ◆ Double PTFE encapsulated O-rings must be fitted so that the joint of the outer sheath points in opposite direction to the mounting direction, so that the friction force generated when sliding on the O-ring closes the joint. Kinks in the foil will result in leakage.

## ■ INSTALLATION TOOLS / EQUIPMENT

- Propyl alcohol + paper tissue (no cleaning rags)
- lubricant for elastomer-sealing rings: Type "TURMOPOLGREASE SH2", make Lubricant Consult (LUBCON)

- Thread-locking compound, e.g. type "LoctiteR Nr. 243", producer: Loctite Corporation
- O-ring extractor
- Set of hex. keys (WAF 2 mm - 6 mm)
- Cardboard washers to protect the contact faces during installation
- Manual screw press (compulsory from DN 80 mm)

## ■ INSTALLATION

Refer to the general pump assembly drawing when installing the mechanical seal.

Mechanical seals are precision-machined machinery components which have been inspected several times. They must be installed with due care and in compliance with certain procedures, particularly regarding the contact faces and elastomer seals.

Utmost cleanliness must be ensured in the immediate vicinity of the location where a mechanical seal is to be installed.

**Never use force** when installing a mechanical seal.

Unpack the seal and inspect the spring-loaded ring, seat ring, O-rings and contact faces for damage.

- Never place the spring-loaded ring and the seat ring on the table facing down without protecting the contact faces.
- Thoroughly clean all parts with alcohol and paper tissue.

The sequence of operations required to install the mechanical seal in the machine depends on the design of the machine in question, which is described in the pump's operating manual.

Unless otherwise stated, apply a very thin coat of grease to O-rings which will slide into or onto other components during mechanical seal installation.

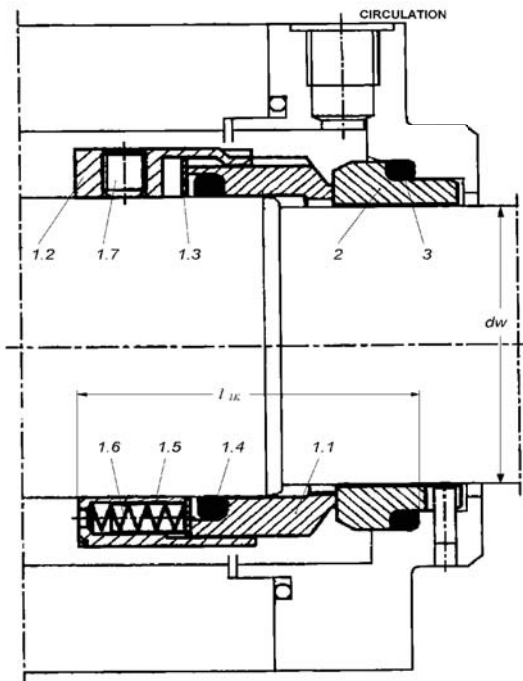

Fig. 1: General mech. seal design

### Primary seal components

1.1	Spring-loaded ring
2	Seat ring

### Secondary seal elements

1.4	O-ring (dynamic)
3	O-ring (static)

### Spring components

1.5	Guide sleeve
1.6	Spring

### Torque transmission and housing components

1.2	Torque-transmitting sleeve
1.3	Thrust ring
1.7	Grub screw

### Possible installation sequence:

- Slide the degreased O-ring onto the seat ring.
- Cover the contact face of the seat ring with a cardboard washer. Generously lubricate the seat ring with water or alcohol and press it slowly and evenly into its seat. Use a spacer, if necessary. Check squareness of seat ring to the shaft axis.
- Apply a thin coat of grease to the shaft protecting sleeve in the mechanical seal area.
  - ◆ Never use mineral oil base lubricants or sealing elements made of ethylene propylene rubber (swelling, possibly decomposition).
- Slide the rotating seal assembly with greased O-rings onto the shaft protecting sleeve.
- Fit the degreased grub screws, having applied one drop of thread-locking compound (e.g. Loctite R No. 243) to each screw.
- Tighten the grub screws to lock the torque-transmitting sleeve in place.
- Clean the contact faces with propyl alcohol and paper tissue (**no cloth, no cleaning rags!**) to remove any smears. Do not touch the contact faces with bare fingers after that.
  - ◆ Do not apply lubricants to the contact faces. The contact faces must be installed in clean and dry condition.
- Fit the seal cover with pre-assembled seat ring.

## ■ COMMISSIONING

Prime the pump and the seal chamber with the fluid handled and vent thoroughly. The seal is now ready for operation.

## ■ SAFE OPERATION

For single mechanical seals, the pressure in the seal chamber of the pump must always exceed ambient pressure, to prevent any air intake at the seal faces, which would result in dry running and thus failure of the mechanical seal.

In all operating conditions, the product to be sealed off must be available in liquid state at the mechanical seal, particularly during pump start-up and shutdown.

If the operating conditions indicated are observed and the instructions given in this operating manual are complied with, the mechanical seal can be expected to give trouble-free operation.

## ■ HEALTH AND SAFETY

Mechanical seals are often used for sealing off hazardous substances (chemicals, pharmaceuticals, etc.). The applicable instructions and regulations for handling hazardous materials must absolutely be adhered to.

Should the mechanical seal fail, the hot liquid or steam to be sealed off may spurt out. Splash guards fitted on the machine, safety goggles worn by the operating staff, etc. may prevent hazards to persons. The operator/owner is responsible for the proper disposal of leakage, in order to prevent hazards to the environment.

### ■ FAULTS/MALFUNCTIONS

Determine and document the nature of the fault/malfunction.

In the event of a fault as evidenced by excessive leakage, observe the tendency of the leakage amount. Changes in operating conditions must be documented. If an excessive temperature rise is detected, the mechanical seal must be shut down for safety reasons.

A continuous flow of leakage indicates a fault/malfunction at the mechanical seal.

During the warranty period the mechanical seal shall only be removed and dismantled with the manufacturer's approval or in the presence of his representative.

If the fault/malfunction cannot be remedied by the operator or if the cause is unclear, please contact your responsible Flo Fab service centre.

### ■ SERVICING / MAINTENANCE

Mechanical seals operated in compliance with manual are maintenance-free. Wear parts, however, must be replaced as required.

The mechanical seal shall be inspected in accordance with the plant inspection schedule. We recommend to have the mechanical seal inspected by competent Flo Fab service staff.

If the mechanical seal is removed during plant inspection, the contact faces shall be re-worked and all elastomer seals and springs shall be replaced.

### ■ REPAIR

If the seal needs to be repaired, always return the complete seal to the manufacturer. The manufacturer's service personnel will know best which parts can be re-worked and which parts have to be replaced to ensure an optimum sealing effect.

If repair on the spot is absolutely necessary (e.g. no spare seal available, long transport distances, problems with customs procedures), skilled operator staff may carry out the repair work in a clean workshop to the directions of the seal manufacturer's fitters.

### ■ SPARE PARTS

Use only genuine spare parts, to prevent

- the risk of mechanical seal malfunction, involving hazards to persons and the environment.
- forfeiture of any and all warranty claims.

To ensure quick mechanical seal replacement, we recommend to stock a complete spare seal.

### ■ REMOVING THE SEAL FROM THE PUMP



- Shut down the pump, allow to cool down and release pressure as per operating instructions.
- No product should contact the mechanical seal ⇒ Drain the pump, if necessary!
- Secure the pump against inadvertent start-up!
- Follow the safety instructions (safety data sheets)!

When removing the mechanical seal make sure to observe the applicable health and safety regulations, as well as the regulations for handling hazardous substances, if the mechanical seal have already been in operation. If in doubt, the necessary information has to be obtained before starting repair work.

Any work on the mechanical seal shall only be performed with the pump shut down and the pump pressure released.

The sequence of operations required to remove the mechanical seal from the pump depends on the design of the pump in question, which is described in the pump's operating manual.

Removal of the mechanical seal shall be effected in analogy with, but in reverse order to, installation.

### ■ CUSTOMER SERVICE

Services provided by the seal manufacturer range from planning advice to product support after commissioning.

For this purpose, the manufacturer has established a worldwide network of subsidiaries abroad, partner companies, sales offices and service stations, to handle any problems.

### ■ PURCHASE ORDERS

For enquiries and purchase orders, the following details are required:

- Flo Fab order No.
- No. of general pump assembly drawing
- Part item No., description, material, quantity as per drawing

### ■ DISPOSAL

Usually, mechanical seals can easily be disposed of after a thorough cleaning.

- Metal parts (steel, stainless steel, non-ferrous metals), shall be sorted and disposed of in the appropriate waste metal collection facility.
- Plastics (elastomers, PTFE) are special waste. After sorting, some of them can be recycled.
  - ◆ **CAUTION!** Material containing fluorine must not be incinerated.
- Ceramic contact face materials (carbon, ceramics, carbide) can be separated from their carrier materials and – being physiologically harmless – disposed of as residual waste.

**We reserve the right to technical modifications designed to improve the product, even if they are not mentioned in this manual yet.**

## 9 Spare Parts

### Recommended Spare Parts

Recommended spare parts stock for 2 years' operation for continuous operation

Part no.	Description	Number of pumps (incl. stand-by pumps)						
		2	3	4	5	6	8	10 and more
		Number of spare parts *						
234	Impeller	1	1	1	2	2	3	30 %
502	Casing wear ring	4	4	4	6	6	8	50 %
503	Impeller wear ring	4	4	4	6	6	8	50 %
211,940 920,932	Shaft with keys and shaft nuts	1	1	2	2	2	3	30 %
321	Rolling element bearing	2	2	4	4	6	8	100 %
524	Shaft protecting sleeve	4	4	4	6	6	8	50 %
461	Packing ring	32	32	48	48	48	64	40 %
411,412 421	Set of sealing elements	4	6	8	8	9	12	150 %
433	Mechanical seal							
	Spring-loaded ring	4	6	8	8	8	12	90 %
	Seat ring	4	6	8	8	8	12	90 %
	O-rings	4	6	12	16	16	20	150 %
	Seals on seat ring	4	6	12	16	16	20	150 %
	Set of springs	1	2	2	2	2	4	%

\* These figures already allow for components required twice for replacement

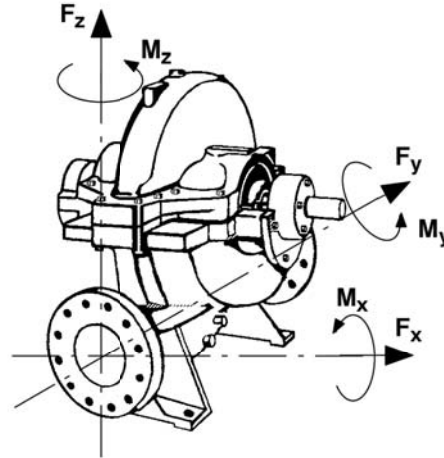
**10 Forces and Moments**

The given forces and moments are mean values for simultaneous loading in the three planes. If the forces and moments in one particular direction are larger than given in the table, consult Flo Fab.

**⚠ The values given in the table do not apply to the reaction forces of braceless expansion joints.**

Dimensions in mm

Pump sizes	Impeller dimensions in mm									Permissible nozzle		Mass moments of inertia J		Permissible operating pressure		Permissible test pressure	
	free passage ± 10 %			max. diameter			Clearances			forces in N	moments in Nm	(without coupling) in kgm <sup>2</sup>		in bar		in bar	
	A	B	C	A	B	C	A	B	C	F <sub>x</sub> , F <sub>y</sub> , F <sub>z</sub> 1); 3)	M <sub>x</sub> , M <sub>y</sub> , M <sub>z</sub> 1); 3)	without water	with water	1)	2)	1)	2)
	15	11	-	215	215	-	0.30	0.30	-	800	500	0.023	0.028	16	25	28	37.5
	13	9	-	275	275	-	0.30	0.30	-	800	500	0.037	0.044	16	25	28	37.5
	11	8	-	345	345	-	0.30	0.30	-	800	500	0.027	0.032	16	25	28	37.5
	19	14	-	254	254	-	0.35	0.35	-	1000	700	0.048	0.058	16	25	28	37.5
	15	11	-	325	325	-	0.35	0.35	-	1000	700	0.092	0.110	16	25	28	37.5
	13	10	-	408	408	-	0.35	0.35	-	1000	700	0.229	0.275	16	25	28	37.5
	23	17	-	245	245	-	0.35	0.35	-	1500	1000	0.161	0.193	16	25	28	37.5
	19	12	-	301	301	-	0.35	0.35	-	1500	1000	0.125	0.150	16	25	28	37.5
	14	10	-	392	392	-	0.35	0.35	-	2000	1500	0.261	0.313	16	25	28	37.5
	14	10	-	482	482	-	0.35	0.35	-	2000	1500	0.688	0.825	16	25	28	37.5
	27	20	14	289	289	289	0.45	0.45	0,45	2500	1500	0.169	0.288	16	25	28	37.5
	22	15	-	355	355	-	0.45	0.45	-	2500	2000	0.199	0.338	16	25	28	37.5
	17	12	-	462	462	-	0.45	0.45	-	2500	2000	0.456	0.775	16	25	28	37.5
	16	11	-	569	569	-	0.45	0.45	-	3000	2000	1.074	1.825	24	25	28	37.5
	30	22	17	338	338	338	0.50	0.50	0,50	4000	2750	0.442	0.575	16	25	24	37.5
	26	18	-	415	415	-	0.50	0.50	-	4000	2750	0.588	0.725	16	25	24	37.5
	20	14	-	540	540	-	0.50	0.50	-	4000	2750	1.288	1.675	16	25	24	37.5
	18	12	-	665	665	-	0.50	0.50	-	4000	2750	3.654	4.750	24	25	28	37.5

- 1) see next page
- 2) see next page
- 3) see next page

Dimensions in mm

Pump sizes	Impeller dimensions in mm									Permissible nozzle		Mass moments of inertia J		Permissible operating pressure		Permissible test pressure	
	free passage ± 10 %			max. diameter			Clearances			forces in N	moments in Nm	(without coupling) in kgm <sup>2</sup>		in bar		in bar	
	A	B	C	A	B	C	A	B	C	F <sub>x</sub> , F <sub>y</sub> , F <sub>z</sub> 1); 3)	M <sub>x</sub> , M <sub>y</sub> , M <sub>z</sub> 1); 3)	without water	with water	1)	2)	1)	2)
	39	27	20	390	390	390	0.5	0.5	0,5	4000	2750	0.721	1.225	10	25	15	37.5
	30	20	-	478	478	-	0.5	0.5	-	4000	2750	0.956	1.625	16	25	24	37.5
	23	16	-	622	622	-	0.5	0.5	-	4000	2750	2.206	3.750	24	25	28	37.5
	39	27	-	323	323	-	0.5	0.5	-	4000	3000	0.571	0.800	10	25	15	37.5
	45	32	30	450	450	450	0.6	0.6	0,6	4000	3000	1.785	2.500	10	25	15	37.5
	35	23	-	553	553	-	0.6	0.6	-	5000	3000	2.411	3.375	16	25	24	37.5
	26	18	-	719	719	-	0.6	0.6	-	5000	3000	6.346	8.250	24	25	28	37.5
	39	27	-	373	373	-	0.5	0.5	-	5000	3000	1.116	1.563	10	25	15	37.5
	57	40	-	430	430	-	0.6	0.6	-	5000	3000	2.232	3.125	10	25	15	37.5
	52	36	35	518	518	518	0.6	0,6	0,6	5000	3000	3.393	4.750	10	25	15	37.5

- 1) Casing material JL 1040 and GGG-NiCrNb 20 2
- 2) Casing material JS 1030 and 1.4517
- 3) Casing material JS 1030; 1,4-times the given value
- 4) Casing material 1.4517; 1,9-times the given value

## 11 Trouble-Shooting

### 11.1 General

The diagram opposite is to facilitate understanding of the causes of faults and their remedies as indicated in the trouble-shooting table.

The cause of many operating faults on pumps is often hydraulic. The hydraulic behavior of a pump is illustrated by its characteristic curves H, P, Eta and NPSH in combination with the plant characteristic curves H<sub>A</sub> and NPSH<sub>A</sub>. The operating point B is where the system curve H<sub>A</sub> and the characteristic curve H intersect. Consult the manufacturer if the cause of a fault is unclear.

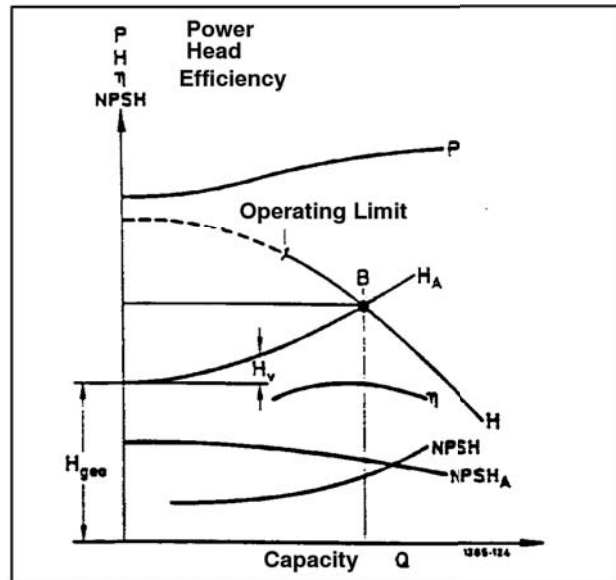



11.2 Trouble-shooting Table

Pump pressure too low	Pump pressure too high	Flow rate too high	Flow rate too low	Power consumption too high	Pump fails to pump liquid after being switched on	Pump ceases to pump liquid	Pump does not run smoothly (noise, vibrations)	Inadmissible temperature increase at pump / seal casing	Bearing temperature too high	Excessive leakage at shaft seal	Drive overloaded	Leakage at pump	Cause	Remedy <sup>1)</sup>
•	•	•	•	•	•		•	•			•		Operating point B does not lie at the calculated intersections of Q and H	Re-adjust operating point
					•								Pump or piping incompletely vented or not primed	Vent.
•			•		•	•	•	•					Suction pipe or impeller blocked	Clean impeller Check plant for impurities Remove deposits in pump and / or piping Check strainer / suction opening
					•	•	•						Formation of air pockets in the piping	Correct suction conditions Alter piping
•			•		•	•	•						Suction head too high (NPSH <sub>available</sub> too low) / water level too low	Check mode of operation Correct suction conditions Increase positive suction head Increase back pressure by throttling Install pump at a lower level Alter intake pipe if resistances are too high
•			•		•	•							Air is drawn in at shaft seal	Clean sealing liquid line, possibly introduce sealing liquid from an external source or increase pressure Check level of liquid in feed tank Replace shaft seal Replace shaft protecting sleeve
•			•	•			•				•		Wrong direction of rotation	Interchange two phases of the power cable Check electrical connections Check impeller position, correct if necessary
•			•				•						Speed too low	Increase speed <sup>1)</sup> , Check switchgear, Fit larger impeller <sup>1)</sup> .
•			•		•	•							Internals worn	Check duty point / pump selection Increase back pressure by throttling Check medium handled for contamination by chemicals and solids content Replace worn components
			•								•		Pump pressure is lower than specified in the order	Re-adjust operating point Increase back pressure by throttling.

Trouble-shooting Table

Pump pressure too low	Pump pressure too high	Flow rate too high	Flow rate too low	Power consumption too high	Pump fails to pump liquid after being switched on	Pump ceases to pump liquid	Pump does not run smoothly (noise, vibrations)	Inadmissible temperature increase at pump / seal casing	Bearing temperature too high	Excessive leakage at shaft seal	Drive overloaded	Leakage at pump	Cause	Remedy <sup>1)</sup>
				•							•		Higher density or viscosity of medium handled than specified in the order	Reduce speed In the case of persistent overloading, turn down impeller, if necessary <sup>1)</sup> .
	•	•		•			•				•		Speed too high	Reduce speed In the case of persistent overloading, turn down impeller, if necessary <sup>1)</sup> .
												•	Tie bolts / seals	Check Tighten tie bolts Replace gaskets Check pipe connections and pump mounting, if necessary, improve mounting of piping.
										•			Worn shaft seal	Check flushing / sealing liquid pressure clean sealing liquid line, possibly introduce sealing liquid from an external source or increase pressure Replace shaft seal Replace worn components Replace shaft protecting sleeve.
•			•				•		•				Unfavourable flow to suction nozzle of pump	Alter piping If necessary, alter intake pipe if resistances are too high Check whether pipe routing results in twisted or irregular flow (e.g. downstream of an elbow) and correct, if necessary.

<sup>1)</sup> Consult Flo Fab

Trouble-shooting Table

Pump pressure too low	Pump pressure too high	Flow rate too high	Flow rate too low	Power consumption too high	Pump fails to pump liquid after being switched on	Pump ceases to pump liquid	Pump does not run smoothly (noise, vibrations)	Inadmissible temperature increase at pump / seal casing	Bearing temperature too high	Excessive leakage at shaft seal	Drive overloaded	Leakage at pump	Cause	Remedy <sup>1)</sup>
							•			•			Lack of cooling liquid or cooling liquid chamber contaminated	Check flushing / sealing liquid pressure Clean sealing liquid line, possibly introduce sealing liquid from an external source or increase its pressure Increase cooling liquid flow Clean cooling liquid line.
							•			•			Pump mis-aligned or resonance vibrations in the piping	Re-align pump / drive Check piping connections and pump mounting, if necessary, improve mounting of piping Apply vibration-damping measures
										•			Excessive axial thrust	Check duty point / pump selection Check mode of operation Check suction - side flow.
										•			Too little, too much or unsuitable lubricant	Clean bearing Replace lubricant Top up, reduce or change lubricant
•			•	•								•	Motor is running on two phases only	Replace defective fuses Check electrical connections Check switchgear.
							•			•	•		Rotor is out of balance	Clean rotor Check run-out, straighten if necessary Re-balance rotor.
							•			•	•		Bearings damaged	Replace / change
							•	•					Flow rate too low	Re-adjust operating point Fully open shut-off valve in the intake pipe Fully open shut-off valve in the discharge pipe Recalculate or measure the hydraulic losses $H_V$ .

<sup>1)</sup> Consult Flo Fab.

Trouble-shooting Table

Pump pressure too low	Pump pressure too high	Flow rate too high	Flow rate too low	Power consumption too high	Pump fails to pump liquid after being switched on	Pump ceases to pump liquid	Pump does not run smoothly (noise, vibrations)	Inadmissible temperature increase at pump / seal casing	Bearing temperature too high	Excessive leakage at shaft seal	Drive overloaded	Leakage at pump	Cause	Remedy <sup>1)</sup>
•			•										In star / delta operation motor hangs at star stage	Check electrical connections Check switchgear.
•			•				•						Inadmissible air or gas content in liquid	Vent Check integrity of suction pipe, seal if necessary
•			•		•	•	•						Air drawn in at pump inlet	Correct suction conditions Reduce flow velocity at suction pipe entry Increase suction head Check integrity of suction pipe and seal, if necessary Replace defective pipes.
							•						Cavitation (rattling noise)	Correct suction conditions Check mode of operation Increase suction head Install pump at a lower level
							•		•				Foundation not rigid enough	Check Alter
•			•		•	•	•						Inadmissible parallel operation	Re-adjust operating point Alter pump characteristic H <sup>1)</sup> .
							•			•			Shaft is out of true	Renew / Replace
			•				•	•	•				Impeller rubs against casing components	Check rotor Check impeller position Check that the piping is connected without transmitting any stresses or strains.

<sup>1)</sup> Consult Flo Fab.

## 12 Routine Maintenance and Inspection Intervals

Interval	Number of personnel required	Time [h]	Maintenance job
Daily	1	1/10	Check leakage on mechanical seal or leakage of packed gland (see section 8.1 " <b>Gland packing</b> ").
Weekly	1	1/4	Check pump operation (positive suction pressure, total head, bearing temperature, noises and vibrations)
Monthly	1	1/4	Check torsional play of coupling (see section " <b>Coupling</b> "), If available, switch to stand-by pump or carry out a test run (for 5 min.)
	1	1/4	
every 20.000 operating hours	2	3	Replace deep-groove ball bearings (see section 7.3 " <b>Dismantling</b> " and 7.4 " <b>Reassembly</b> ").
every 4 years or if total head of pump drops	2	6	General inspection and overhaul of pump in accordance with the operating instructions.  Check and renew, if required: <ul style="list-style-type: none"> <li>- wear parts such as: bearings, casing wear ring (impeller wear ring, if any), shaft protecting sleeve</li> <li>- impeller and shaft</li> <li>- Replace sealing elements</li> </ul>

**13 Appendix**

<b>Contents</b> .....	<b>Page</b>
<b>Types of installation</b> .....	<b>38</b>
<b>Type of Installation H - Motor Height Adjustment</b> .....	<b>39</b>
- Type of Installation H - Motor Height Adjustment Baseframe with Base/Shims under the Motor feet	39
- Sealing / flushing water piping	40
- Arrangement of sealing water and flush pipe	40
<b>Sealing water pipe for mechanical seal</b> .....	<b>41</b>
<b>Coupling</b> .....	<b>42</b>
- Trouble-shooting	42
<b>General drawing of pump with parts list Shaft seal: Mechanical seal</b> .....	<b>43</b>
<b>Mechanical seals, standard design</b> .....	<b>45</b>
<b>Shaft seal - mechanical seals - Type Crane 58U and 58B</b> .....	<b>47</b>

**Types of installation**

**Horizontal**

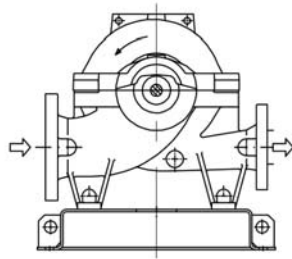

**Type of installation H**

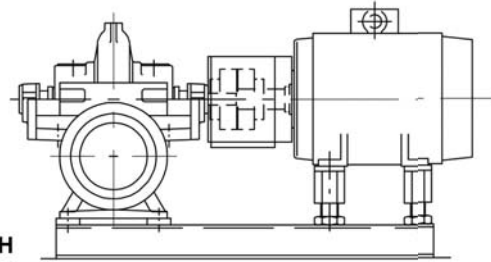

**Pump set with close-coupled motor (type IM B3) <sup>1)</sup>  
Baseplate, baseframe, coupling guard and motor height adjustment**

**Vertical**

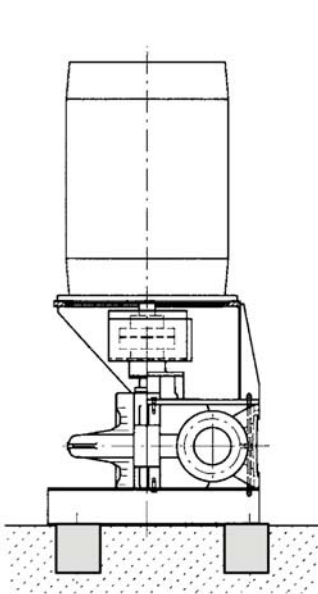

**Type of installation VB <sup>2)</sup>**

<sup>2)</sup> Depending of motor size

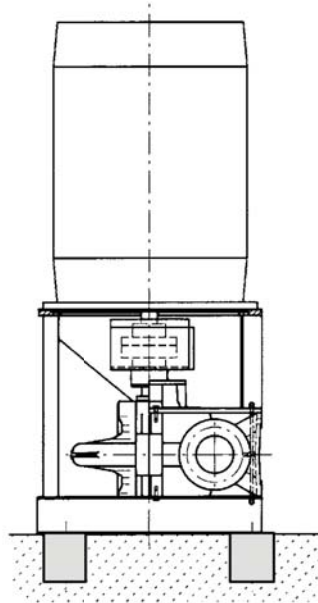

**Type of installationVK <sup>2)</sup>**

**Direction of rotation / flow direction**

**Horizontal**

Direction of rotation  
**counter-clockwise**  
viewed from the drive end

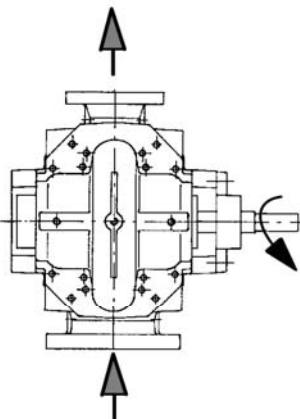

Direction of rotation  
**clockwise**, viewed from the  
drive end

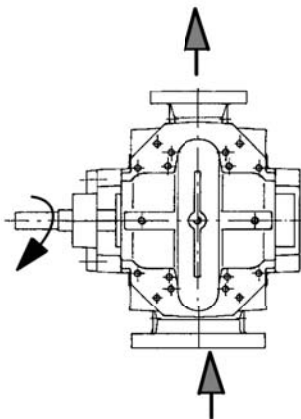

**Vertical**

Direction of rotation  
**counter-clockwise**,  
viewed from the drive end

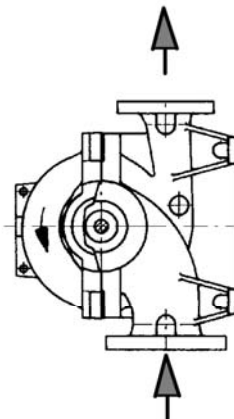

Direction of rotation  
**clockwise**, viewed from the  
drive end

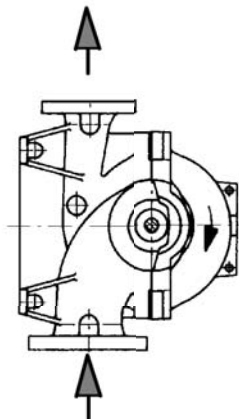

<sup>1)</sup> General arrangement drawing "Pump set 3 E - Baseplate/baseframe with motor height adjustment" shows the main variants available

Type of Installation H - Motor Height Adjustment - Baseframe with Base / Shims under the Motor Feet

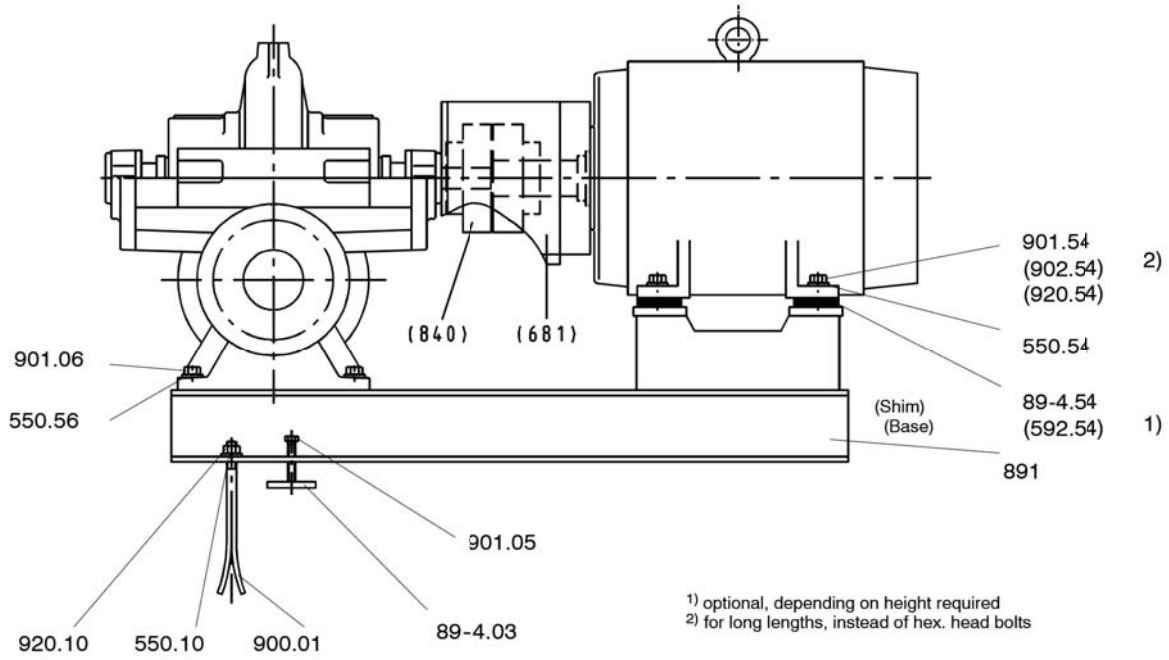

Part no.	Description
89-4	Shim
180	Pedestal
550	Washer
592	Base
890	Baseplate
900	Screw
901	Hex. head bolt
902	Stud
909	Adjusting screw
920	Nut



**Sealing / flushing water piping**

The pump is equipped with sealing / flushing water piping. These pipes are sheathed PTFE hoses which are flexible, temperature and highly pressure resistant.

Another favourable property of PTFE (polytetrafluorethylene) is the extremely low friction coefficient which prevents pipe clogging.

Normally we supply this assembly ready mounted to the pump. If this is not the case, mount the hoses and fittings as per the attached drawings (see appendix).

**Arrangement of sealing water and flush pipes**

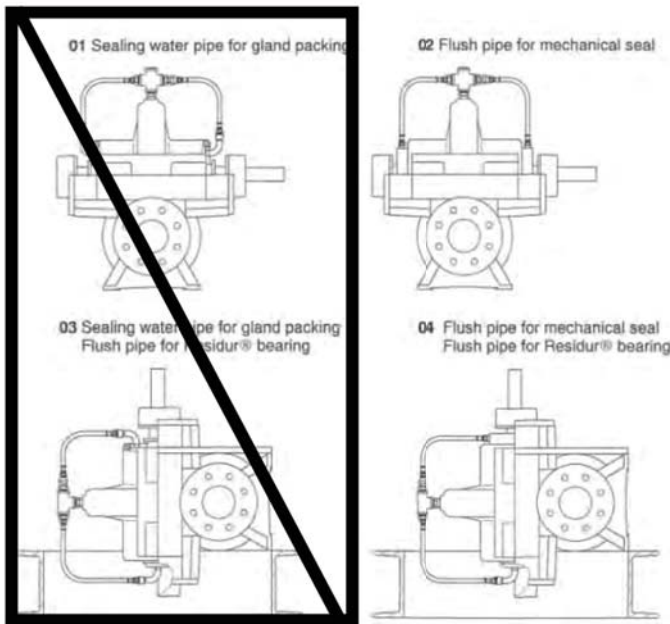

**Arrangement of venting connections and bearing temperature sensor** (vent valves are available as accessories)

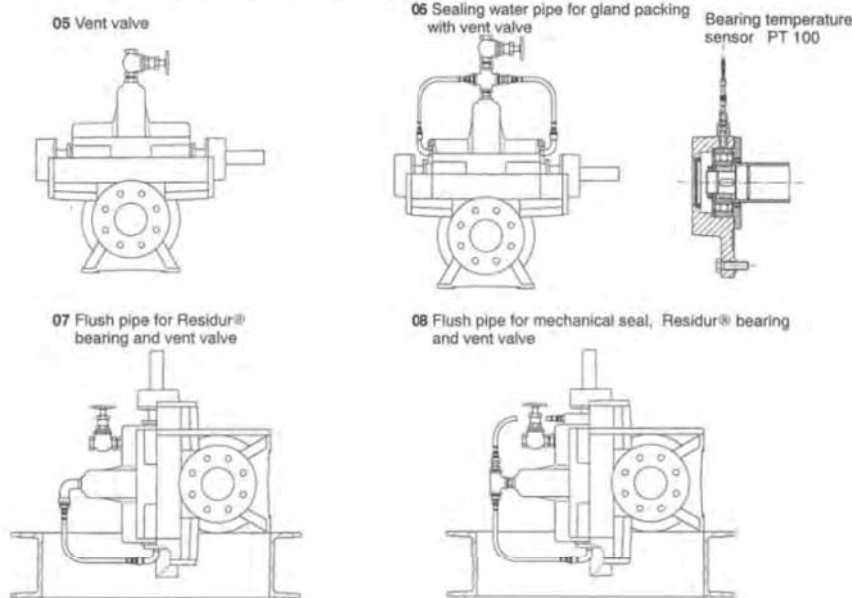

Sealing water pipe for mechanical seal

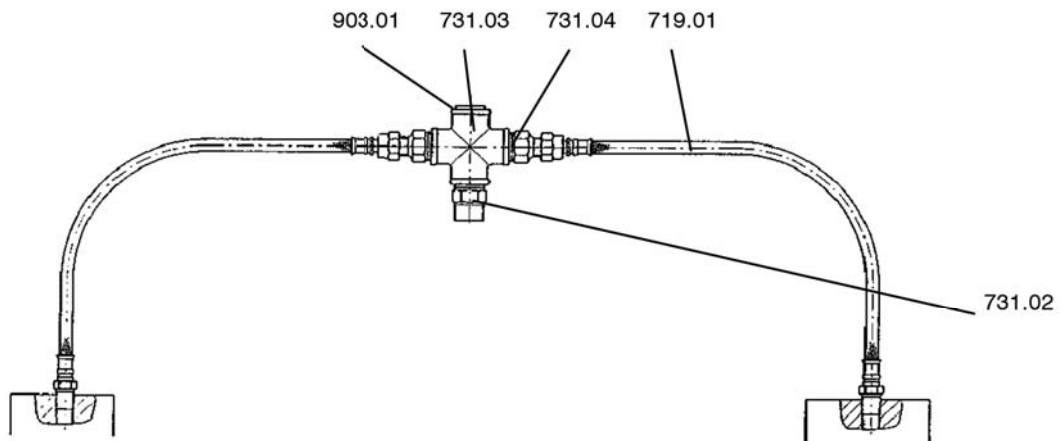

Part no.	Description
719.01	Flexible tube
731.02	Nipple joint
731.03	Cross
731.04	Nipple joint
903.01	Screwed plug

## SERIES 4800/4900V VERTICAL SPLIT CASE PUMP SECTIONAL DRAWING (GREASE LUB)

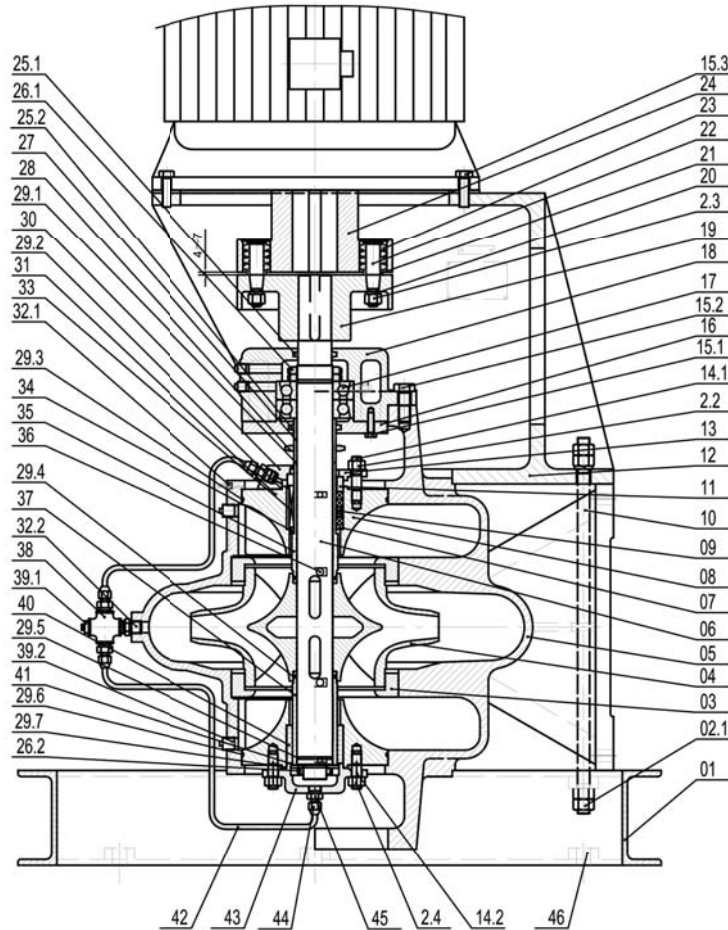

No.	Parts Name	Material	No.	Parts Name	Material	No.	Parts Name	Material	No.	Parts Name	Material
01	Base Plate	Q235-A Carbon Steel	15	Screw Bolt	4.8	29	O-ring	Buna-Nrubber	43	Bearing Bush Cover	Cast Iron GG20
02	Nut	6	16	Bearing Cover	Cast Iron GG20	30	Mech-seal Cover	Cast Iron GG20	44	Nut B8	20
03	Casing Wear Ring	Cast Iron GG25	17	Angular Contact Ball Brg.	GCr15	31	Mech-seal Housing	Cast Iron GG20	45	Pipe Joint	Q235-A Carbon Steel
04	Impeller	QT600-3	18	Bearing Housing	Cast Iron GG20	32	Pipe Joint	KTH300-06	46	Anchor Bolt	Q235-A Carbon Steel
05	Casing	Cast Iron GG25	19	Pump Half Coupling	Cast Iron GG20	33	Mechanical Seal	As Per Working Cond.	47	Casing Gasket	Highland Barley Paper (Not Shown)
06	Shaft	45 Carbon Steel	20	Washer	65Mn	34	Neck-ring/Mech-seal	Cast Iron GG20			
07	Neck-ring/Packing	Q235-A Carbon Steel	21	Washer	Q235-A Carbon Steel	35	Shaft Sealing Sleeve	Cast Iron GG20			
08	Packing Seal Housing	Cast Iron GG25	22	Pin	45 Carbon Steel	36	Dowel Pin	65Mn			
09	Lantern Ring	Cast Iron GG20	23	Elastic Ring	Rubber	37	Shaft Slide Sleeve	AISI 420/2Cr13			
10	Tighten Bolt	Q235-A Carbon Steel	24	Motor Half Coupling	Cast Iron GG20	38	Cross Joint	KTH300-06			
11	Split Ring	Cast Iron GG20	25	Radial Shaft Seal Ring	Wool Felt	39	Square Plug	KTH300-06			
12	Motor Bracket	Q235-A Carbon Steel	26	Round Nut	45 Carbon Steel	40	Bearing Bush	Composite Material			
13	Gland	Cast Iron GG20	27	Brg. Spacer Sleeve	Cast Iron GG20	41	Disc Spring	60Si2MnA			
14	Stud Bolt	4.8	28	Deflector	Rubber	42	Flushing Pipe	Copper Tube			

<b>SPARE PARTS <u>CODE</u> FOR SERIES 4800/4900V PUMP</b>		
<b>√</b>	<b>MODEL &amp; SIZE</b>	<b>CODE</b>
	5X3X8.4	125V14
	5X3X13.58	125V39
	5X3X9.84	125V90
	6X4X10	150V19
	6X4X12.20	150V31
	6X4X16.06	150V51
	6X4X14.76	150V52
	8X6X10.94	200V21
	8X5X11.8	200V25
	8X6X13.58	200V38
	8X5X17	200V47
	8X6X17.8	200V66
	8X5X18	200V76
	8X6X21.33	200V105
	10X8X12.7	250V30
	10X8X16.22	250V52
	10X8X20.7	250V91
	12X10X14.76	300V39
	12X10X18.18	300V66
	14X12X13.3	350V12
	14X12X12.12	350V24
	16X14X15.03	400V32
	16X12X17.32	400V53
	18X16X17.2	450V42
	18X16X17.4	450V43
	20X20X15.3	500V13
	20X20X18.3	500V22
	20X20X20	500V59
	20X20X22	500V66

DATE: 2010/11/23

## SERIES 4800/4900H SPLIT CASE PUMP (PACKED / MECH-SEAL TYPE) GREASE LUBRICATED CROSS SECTIONAL DRAWING

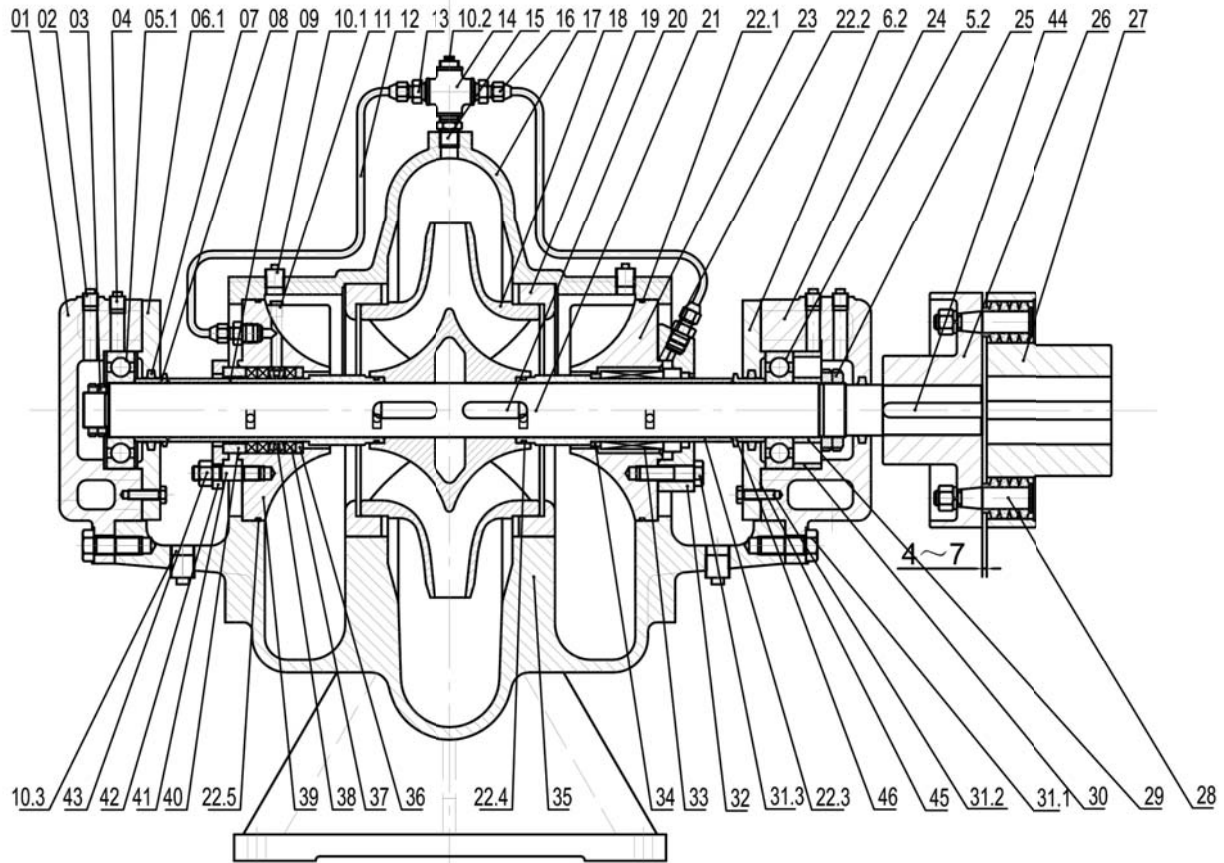

No.	Parts Name	Material	No.	Parts Name	Material	No.	Parts Name	Material	No.	Parts Name	Material
01	Out. Brg Housing	Cast Iron GG20	15	Inner Joint 1/2	KTH300-06	29	Inner Retaining Ring	Cast Iron GG25	43	Hexagon Nut	6
02	Square Plug	KTH300-06	16	Nut B8	20	30	Outer Retaining Ring	Cast Iron GG25	44	Key	45# Carbon Steel
03	Lock Nut	45# Carbon Steel	17	Upper Casing	Cast Iron GG25	31	Screw Bolt	4.8	45	Brg Cover Gasket	Paper
04	Grease Fitting	Copper Alloy	18	Impeller	Cast Iron GG25	32	Mech-seal Cover	Cast Iron GG20	46	Deflector	Rubber
05	Deep Groove Ball Brg.	GCr15	19	Casing Wear Ring	Cast Iron GG25	33	Mech-seal	As Per Working Cond.	47	Casing Gasket	Highland Barley Paper (Not Shown)
06	Brg. Cover	Cast Iron GG20	20	Key	45# Carbon Steel	34	Neck-ring/Mech-seal	Cast Iron GG25			
07	Radial Shaft Seal Ring	Wool Felt	21	Shaft	45# Carbon Steel	35	Lower Casing	Cast Iron GG25			
08	Brg. Spacer Sleeve	Cast Iron GG20	22	O-ring	Buna-Nrubber	36	Neck-ring/Packing	Cast Iron GG25			
09	Shaft Sealing Sleeve	AISI 420/2Cr13	23	Mech-seal Housing	Cast Iron GG25	37	Gland Packing	PTFE			
10	Square Plug 1/2	KTH300-06	24	Inb. Brg. Housing	Cast Iron GG20	38	Lantern Ring	Cast Iron GG20			
11	Square Plug 1/4	KTH300-06	25	Lock Nut	45# Carbon Steel	39	Packing seal housing	Cast Iron GG25			
12	Flushing Pipe	Copper Tube	26	Pump Half Coupling	Cast Iron GG20	40	Split Ring	Cast Iron GG20			
13	Pipe Joint	Q235-A Carbon Steel	27	Motor Half Coupling	Cast Iron GG20	41	Stud Bolt	4.8			
14	Cross Joint 1/2	Cast Iron GG20	28	Coupling Pin	45# Carbon Steel	42	Gland	Cast Iron GG25			

<b>SPARE PARTS <u>CODE</u> FOR SERIES 4800/4900H PUMP</b>		
<b>√</b>	<b>MODEL &amp; SIZE</b>	<b>CODE</b>
	5X3X8.4	125H14
	5X3X13.58	125H39
	5X3X9.84	125H90
	6X4X10	150H19
	6X4X12.20	150H31
	6X4X16.06	150H51
	6X4X14.76	150H52
	8X6X10.94	200H21
	8X5X11.8	200H25
	8X6X13.58	200H38
	8X5X17	200H47
	8X6X17.8	200H66
	8X5X18	200H76
	8X6X21.33	200H105
	10X8X12.7	250H30
	10X8X16.22	250H52
	10X8X20.7	250H91
	12X10X14.76	300H39
	12X10X18.18	300H66
	14X12X13.3	350H12
	14X12X12.12	350H24
	16X14X15.03	400H32
	16X12X17.32	400H53
	18X16X17.2	450H42
	18X16X17.4	450H43
	20X20X15.3	500H13
	20X20X18.3	500H22
	20X20X20	500H59
	20X20X22	500H66

DATE: 2010/11/23

**Coupling - Trouble-shooting**

**General**

The faults listed below shall serve as orientation only when determining failure causes.

In a complex plant system, all other components will have to be included in the search for possible failure causes.

The coupling shall give low-noise and vibration-free operation in all phases of operation. Any other operating behaviour shall be considered a fault which must be remedied immediately.



**Before commencing any maintenance, repair or other work on the coupling, the operator must shut down the entire driving mechanism. The drivers, in particular, must be secured against inadvertent start-up.**

**Also, the accident prevention regulations in force at the installation site shall be complied with.**

**Trouble-shooting list**

Fault	Possible causes	Remedy	
Sudden change in noise level and/or sudden vibrations	Misalignment	Shut down the unit.	
		Eliminate cause for misalignment, if any. (E.g. re-tighten the foundation bolts).	
		Inspect for wear, proceed as described in section "Coupling - Maintenance and Repair"	
	Flexibles are worn	Shut down the unit.	
	Torque transmission by metal-to-metal contact		Dismantle the coupling and remove what is left of the flexible coupling blocks.
			Inspect the coupling parts and replace any damaged components.
Coupling blocks shall always be replaced by complete sets of new coupling blocks; only use coupling blocks with identical markings.			
Verify alignment and correct, if necessary.			
		Check the tightening torques of the screwed connection between parts 2 and 3.	

**Maintenance and repair**

**General**

The torsional play between the two coupling parts shall be checked in acc. with the maintenance schedule of the plant, but at least once a year.

If torsional play must not be limited for extremely smooth coupling operation, the plastic flexibles can be allowed to wear down to approx. ¼ of their original thickness before they have to be replaced. To assess the wear condition of the coupling blocks, the table below indicates the permissible torsional play as indicated by the chord dimension  $\Delta S_V$  on the outside coupling diameter.

To determine the chord dimension  $\Delta S_V$ , rotate one coupling part by hand up to the stop and mark the coupling parts (see illustration). Hand-rotate one coupling part into the opposite direction up to the stop. The two marks will diverge. The distance between the marks is the chord dimension  $\Delta S_V$ . If  $\Delta S_V$  exceeds the value given in the table, the flexible coupling blocks have to be replaced.

**Caution** Coupling blocks shall always be replaced by complete sets of new coupling blocks; only use coupling blocks with identical identification numbers.

### Mechanical seals, standard design

Standardized mechanical seal to DIN 24960 - short design, non-balanced  
 Sizes for shaft diameter  $d_w = 40$  to  $80$  mm (with single spring)

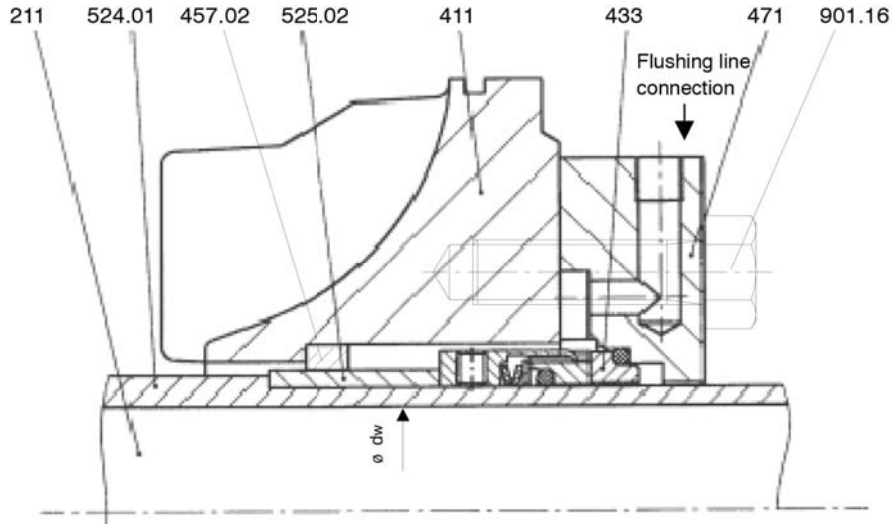

Standardized mechanical seal to DIN 24960 - short design, non-balanced  
 Sizes for shaft diameter  $d_w = 90$  mm (with multiple spring arrangement)

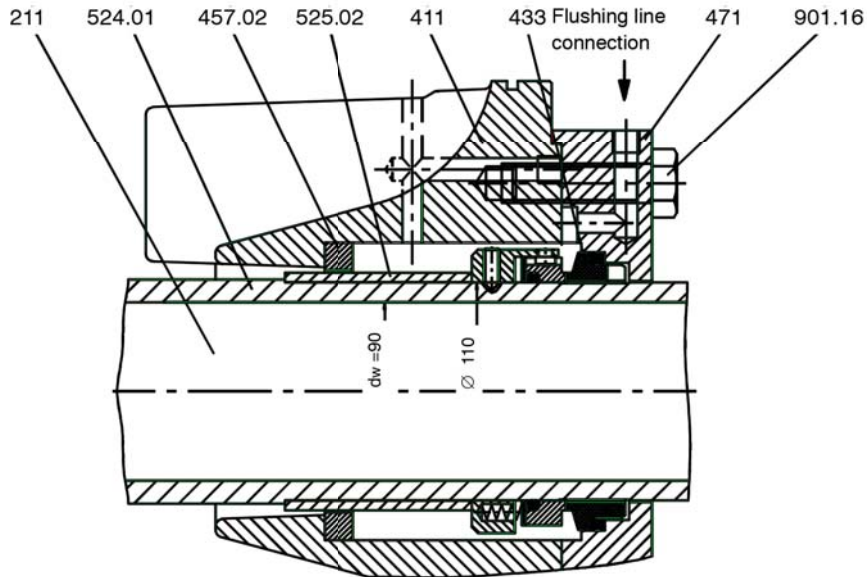

Part no.	Description
211	Pump shaft
433	Mechanical seal
441	Housing for shaft seal
457.02	Neck ring

Part no.	Description
471	Seal cover
524.01	Shaft protecting sleeve
525.02	Spacer sleeve
901.16	Hexagon head bolt



### Mechanical seals, standard design

Balanced mechanical seal (for operating pressures > 16 bar) to DIN 24960  
 Sizes for shaft diameter  $d_w = 40$  to  $80$  mm (with covered spring)

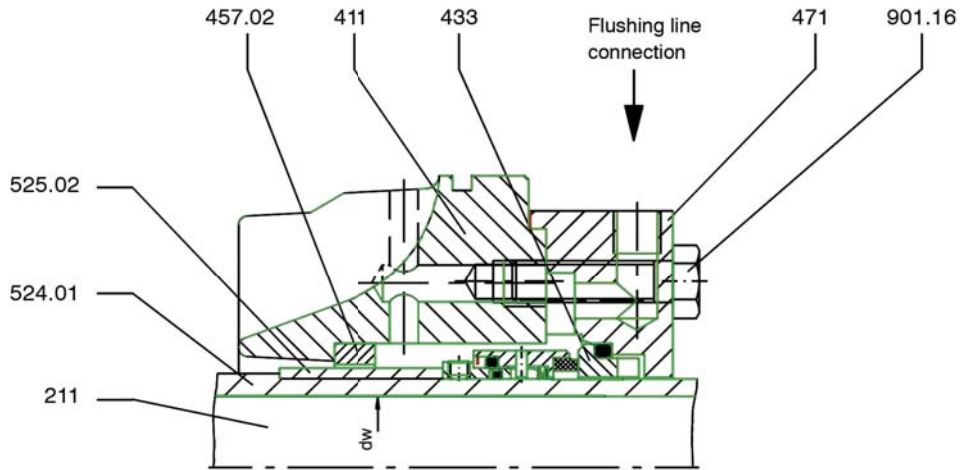

Balanced mechanical seal (for operating pressures  $p > 16$  bar) to DIN 24960  
 Sizes for shaft diameter  $d_w = 90$  mm (with multiple spring arrangement)

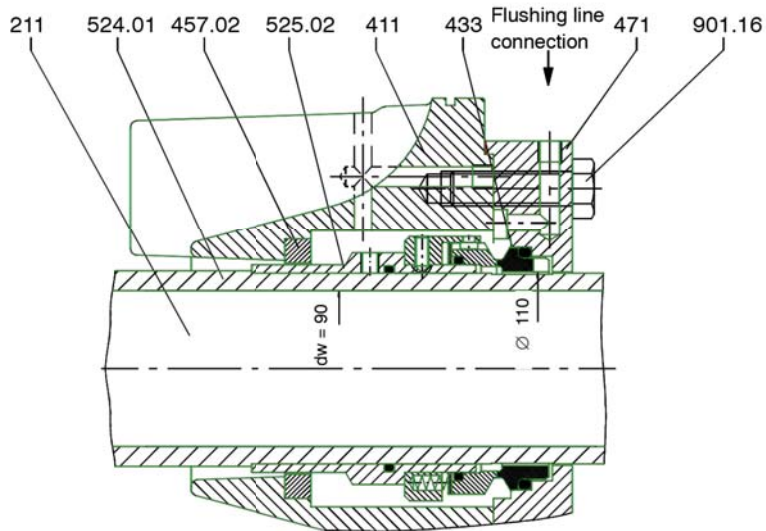

Part no.	Description
211	Pump shaft
433	Mechanical seal
441	Housing for shaft seal
457.02	Neck ring

Part no.	Description
471	Seal cover
524.01	Shaft protecting sleeve
525.02	Spacer sleeve
901.16	Hexagon head bolt

## Shaft seal - mechanical seals - Type Crane 58U and 58B

### Description

The mechanical seals, 58U and 58B, are precision-made and must be treated accordingly. The contact faces are lapped to a high degree of accuracy and prior to despatch they are covered in a protective sleeve to prevent damage. If the protective sleeve is removed for installation purposes, then great care must be taken to avoid any damage to the finely finished, lapped surfaces.

Whenever replacing worn out or damaged mechanical seals, the section of the shaft or sleeve which will accept the new seal must be cleaned and oiled.

### Preparation for installation

1. The installation dimensions and tolerances must comply with those outlined in the relevant literature.
2. The cover which will accept the seat ring must be checked with regard to depth and installation dimensions.

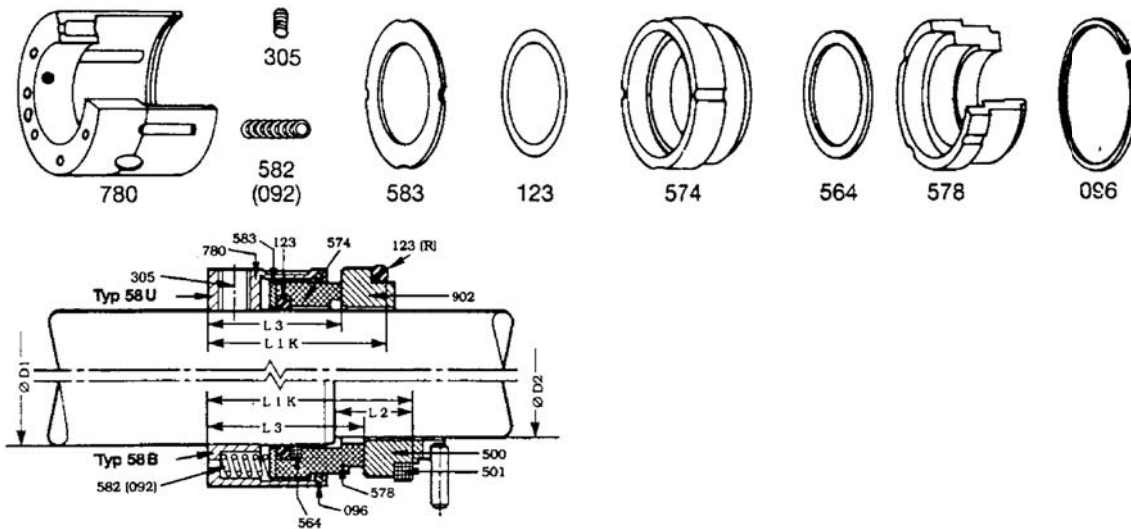

780	Retainer	578	Balanced face
305	Grub screw	096	Snap ring
582 (092)	Spring	500	Seat type BP
583	Thrust ring	501	Seat ring
123	O-ring	902	Seat type BO
574	Rotating face	123 (R)	O-ring
564	Support ring		

### Installation and operation

1. Clean and lightly lubricate the shaft / sleeve with a suitable lubricant.

#### Caution:

Sealing elements manufactured in EP-Elastomer materials must not come in contact with mineral oil and grease.

2. Push on the rotating unit applying light manual pressure.

3. Push the seat ring together with the joint ring into the cover applying even manual pressure. The joint ring shall also be lubricated using a suitable lubricant.

4. The contact faces must be cleaned prior to installation into the machine. Tighten the cover bolts evenly. Overtightening can affect the true running of the rubbing faces and therefore have an adverse effect on the functioning of the mechanical seal.

5. Manually turn the shaft. Fill the machine whilst simultaneously monitoring the venting equipment within the seal area. Check the circulation pipe.

**Dismantling and assembly of the rotating unit**

The first step is to remove the snap ring (096) from the retainer (780). The springs are compressed to achieve this. This can be done by using a simple tool, as illustrated.

**Caution** Lapped surfaces of the rotating face must be protected.

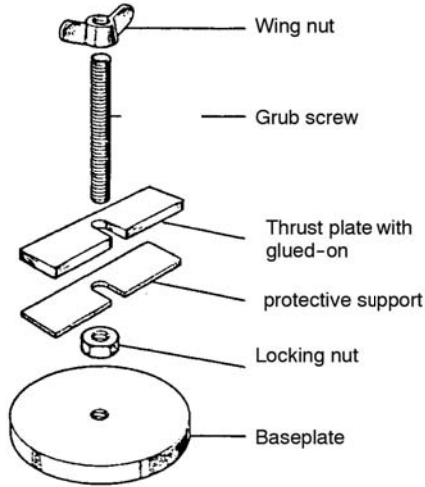

1. The rotating face (574 / 578) is pushed down and the snap ring (096) is removed from the groove using a pointed tool.

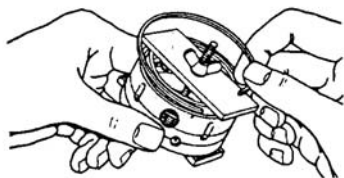
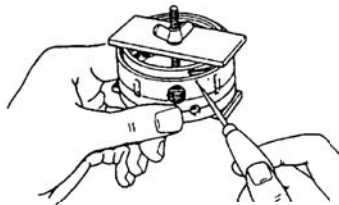

2. Now remove in the following sequence: the rotating face (574 / 578), the O-ring (123), the thrust ring (583) and the springs (582 / 092).

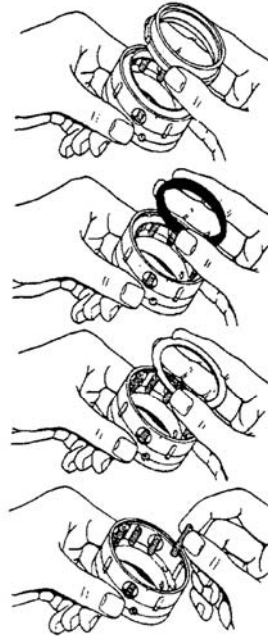

Assembly is carried out in reverse sequence.

**The following must be noted during assembly:**

The drive cams in the retainer (780) must engage into the grooves of the thrust ring (583) or the rotating face (574 / 578) .

Fit the snap ring (096) into the groove of the retainer (780), leaving one end of the snap ring protruding by approx 6 - 12 mm to the side of the drilled hole.



At the outer circumference of the retainer (780) there are 2 marker grooves. The lower one runs precisely through the centre of the drilled hole for the internal socket head screws, which indicates that the thread of the screws is metric.

The upper groove assists during installation. If the initial tension of the mechanical seal is set correctly to the installation length, then the thrust ring shall be in alignment (be flush) with this groove.



# 1A1 MODEL Cartridge Filter Housing



The 1A1 MODEL Cartridge Filter Housing is an all-metal, two-piece housing, featuring centerpost-type construction. The 1 A1 Model has a maximum operating temperature and pressure of 125 psig at 200°F. The 1A1 Model Cartridge Filter Housing has flow rates to up to 6 Gallons Per Minute (GPM).

## APPLICABLE FILTER CARTRIDGES

Micro-Klean-III (Series U30)

Betapure-

## DESIGN FEATURES

- All-metal, two-piece construction.
- Head and Sump Durable die-cast aluminum
- Mounting pads drilled to accept self-tapping screws provided with the optional mounting bracket.
- Centerpost-type design for easy cartridge changeout.

## Options

- Mounting bracket; order separately.

## STANDARD MODEL SPECIFICATIONS

Table 1 gives specifications for the 1A1 Model. Note that Maximum Operating Pressure is the rating for the housing only. Actual filter operating temperature depends on temperature capability of the filter cartridge used in the housing.

Operating Data	1A1 Model
Maximum Operating Pressure and Temperature	125 psi @ 200°F
Flow Rate (GPM)	See Table 2.
Materials of Construction	
Head and Sump	Die-Cast Aluminum
Centerpost	Stainless Steel
Head Gasket	Buna N & Cork
Cap-Nut Gasket	Fiber
Connection Sizes	3/8" NPTF
Cartridge Requirements	The model uses one filter cartridge. See "Cartridge Requirements" for more information.

TABLE 1 - SPECIFICATIONS

## CARTRIDGE REQUIREMENTS

The 1A1 Model Cartridge Filter Housing uses one Micro-Klean III Cartridge or one Betapure Cartridge Filter.

## FLOW RATES

Table 2 gives maximum flow rates in Gallons Per Minute (GPM) for the 1A1 Model Cartridge Filter Housings. Do not use Table 2 for filter sizing. Use the table as a guide only in establishing the housing flow rates. When you know the flow rate for a selected cartridge, then use the table to determine whether or not the housing is within the recommended flow rate. Remember to consider the amount of contaminant to be removed when selecting a filter.

Housing Model	Inlet / Outlet	FLOW (GPM)					
		Water	80 SSU	150 SSU	300 SSU	600 SSU	1000 SSU
1A1	3/8" NPTF	6	5	4.5	4	3.5	3

TABLE 2 - RECOMMENDED FLOW RATES

HS.1A1.0692  
REPLACES  
HS.1A1.0590

## BENEFITS

- Long Service Life
- Quick and Easy Cartridge Change-out
- Reduced Down Time for Filter Change-out
- Reduced Labor Cost
- Uses Standard Filters
- Economical
- Easily Mounted to Wall or Support Structure



## STANDARD MODEL DIMENSIONS

Table 3 gives dimensions in inches and shipping weight in pounds for the 1A1 Model Cartridge Filter Housing. These should be used for rough plumbing and approximate size definition. Note that figure 1 defines a length or width by a letter symbol in the top row. The square where the row and column meet is the selected dimension.

Model	A	B	C	D	Shipping Weight
1A1	6 3/16"	4 15/16"	3 1/2"	2 3/4"	3 lbs

TABLE 3. - 1A1 HOUSING DIMENSIONS

## 1A1 MODEL ORDERING GUIDE

Plant Code 01      Product Code 020

Model	Catalog Number	Mounting Bracket Kit*
1A1	44109-01	35581-05

\* Order Separately

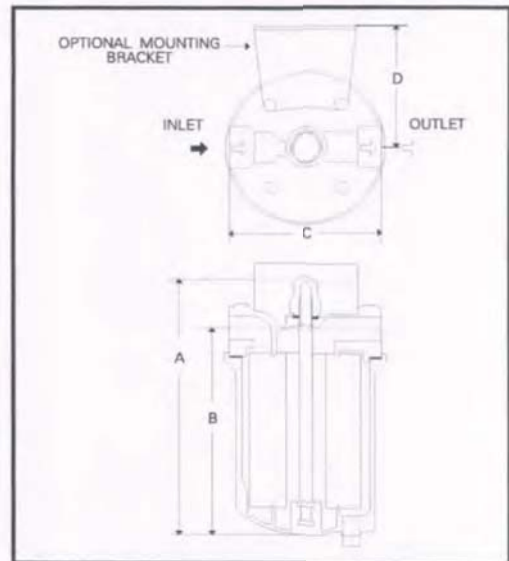
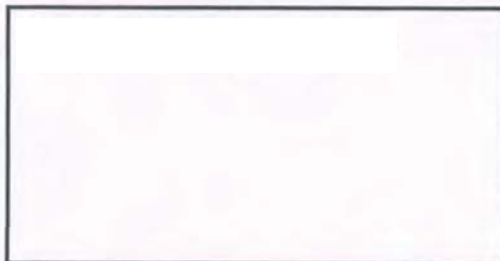

FIGURE 1. - 1A1 MODEL FILTER HOUSING

## WARRANTY

Seller warrants its equipment against defects in workmanship and material for a period of 12 months from date of shipment from the factory under normal use and service and otherwise when such equipment is used in accordance with instructions furnished by Seller and for purposes disclosed in writing at the time of purchase, if any. Any unauthorized alteration or modification of the equipment by Buyer will void this warranty. Seller's liability under this warranty shall be limited to the replacement or repair, F.O.B., point of

manufacture, of any defective equipment or part which, having been returned to the factory, transportation charges prepaid, has been inspected and determined by Seller to be defective. THIS WARRANTY IS IN LIEU OF ANY OTHER WARRANTY, EITHER EXPRESSED OR IMPLIED, AS TO DESCRIPTION, QUALITY, MERCHANTABILITY, FITNESS FOR ANY PARTICULAR PURPOSE OR USE, OR ANY OTHER MATTER. Under no circumstances shall Seller be liable to Buyer or any third party for any loss of profits or





## LONG TERM STORAGE

Here are some general suggestions for long term storage. The applicability of all, or some, of these suggestions depends on several factors such as type of equipment, length of storage, and condition of the environment.

## GENERAL CARE

Drain the casing completely and dry it thoroughly, including its bearing housing and stuffing box, or seal chamber. Apply a coat of soluble rust preventive solution both internally and externally.

Cover all openings. Flanged openings (such as suction and discharge nozzles) should be covered with blind flanges with elastomer gasket. Threaded openings should be covered with steel plugs or caps.

Protect the bearing housing from moisture by placing bags of vapor phase inhibitor crystals around the housing.

Cover the equipment with industrial strength plastic, preferably transparent to allow its visual inspection, including its nameplate, without uncovering the unit.

Store the unit in its normal position in a dry place.

Inspect the unit periodically and turn the shaft a few times at least 1/4 turn. Turning the shaft prevents pitting of finished surfaces. The extra 1/4 turn is to displace the sag and prevent the shaft from developing a permanent bow.

This needs to be done at least once a month

We are proud supplier for the following  
completed and on going projects :

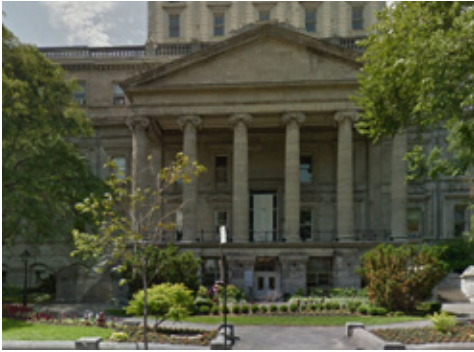

**Ville de Montréal**  
85 rue Notre-Dame E,  
Montréal, QC, CA



**Collège de  
Maisonneuve**  
3800 rue Sherbrooke E,  
Montréal, QC, CA

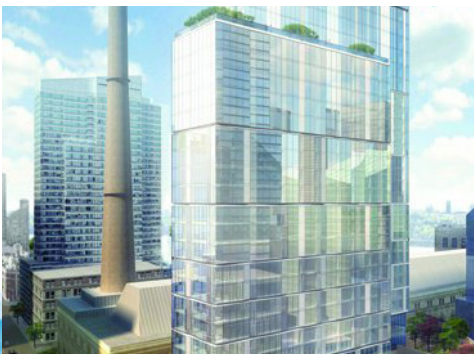

**Riverside Center  
Building 5**  
1 Avenue West End  
NY, US

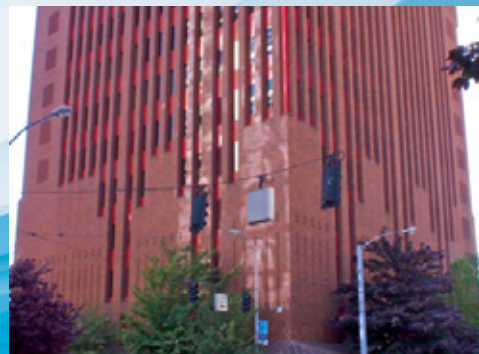

**Building 2101**  
2101 2e Avenue, Seattle,  
Washington, Belltown

## Sales and Service:

Quebec, Canada  
Tel. : (450) 621-2995  
Fax : (450) 621-4995

Lake Worth  
Florida, USA  
33467-5749

Toronto, Canada  
Tel. : +1 (647) 544-2995

[www.flofab.com](http://www.flofab.com)

SERVICE 24/7 : [parts@flofab.com](mailto:parts@flofab.com)

