



Pompes Centrifuges

Séries 880

Opération, Maintenance
& Manuel d'Installation



CAUTION!!

DO NOT RUN PUMP DRY, SEAL DAMAGE MAY OCCUR. INSPECT PUMP SEAL REGULARLY FOR LEAKS, REPLACE AS REQUIRED.

FOR LUBRICATION REQUIREMENTS, CONSULT SERVICE INSTRUCTIONS. FAILURE TO FOLLOW INSTRUCTIONS COULD RESULT IN INJURY OR PROPERTY DAMAGE. COUPLER ALIGNMENT IS REQUIRED! LEVEL AND GROUT PUMP BEFORE USE!

CHECK ALIGNMENT BEFORE GROUTING, AFTER SYSTEM 18 FILLED, AFTER SERVICING PUMP, AND AS REQUIRED.

CONSULT THE SERVICE INSTRUCTIONS FOR DETAILS. FAILURE TO FOLLOW THESE

INSTRUCTIONS COULD RESULT IN INJURY OR PROPERTY DAMAGE. FAILURE TO FOLLOW THIS INSTRUCTION MAY VOID THE WARRANTY OF THE UNIT.

POMPES VERTICALES EN LIGNE

Les pompes FLO FAB de type Vertical En Ligne sont conçues pour un montage vertical sur le tuyau avec le moteur au-dessus de la pompe. L'alignement des conduites d'aspiration et de refoulement assure l'équilibre de la pompe sur les tuyaux. Aucun raccord flexible n'est nécessaire pour compenser le désalignement des tuyaux puisque la pompe n'est fixée qu'aux tuyaux mêmes et peut se déplacer avec les expansions et compressions du réseau des conduites.

Le choix du type de support doit être fait en tenant compte de la disposition des tuyaux près de la pompe, de la taille et du poids des tuyaux et des accessoires de la pompe, des expansions et compressions possibles, etc.... En d'autres termes, les critères généraux de support des tuyauteries s'appliquent en considérant de plus que le poids de la pompe est concentré en un point de la tuyauterie. Les autres recommandations générales concernant les tuyaux restent les mêmes que pour tout autre type de pompe. Par exemple, des robinets-vannes doivent être installés de part et d'autre de la pompe pour permettre le démontage de celle-ci sans avoir à drainer entièrement le réseau.

ATTENTION

Il y a deux méthodes d'installation possibles pour les pompes verticales en ligne

1. POMPES VERTICALES EN LIGNE SUPPORTÉES

INSTALLER LA POMPE DE TYPE VERTICAL EN LIGNE AVEC LE MOTEUR EN POSITION VERTICALE. S'ASSURER QUE L'ESPACE PRÉVU AU -DESSUS DE LA POMPE EST SUFFISANT POUR SOULEVER LE MOTEUR ET L'ENSEMBLE ROTATIF DE LA POMPE HORS DU CORPS DE POMPE . L'ESPACE PRÉVU AUTOUR DE LA POMPE DOIT ÉGALEMENT ÊTRE SUFFISANT POUR L'ENTRETIEN ET LA VENTILATION .

SUPPORTER LA POMPE UNIQUEMENT PAR LES TUYAUX.

LA POMPE NE DOIT PAS ÊTRE APPUYÉE AU SOL.

LA POMPE DOIT ÊTRE FIXÉE UNIQUEMENT PAR SES DEUX BRIDES.

C'EST APPLICABLE POUR TOUTES LES DIMENSIONS DE POMPES.

LA TUYAUTERIE DOIT ÊTRE SOLIDEMENT FIXÉE AU SOL POUR ÉVITER DE TRANSFÉRER L'EFFORT À LA POMPE.

PURGER MANUELLEMENT L'AIR DU CORPS DE POMPE.

S'ASSURER QUE LA VANNE D'ASPIRATION EST GRANDE OUVERTE AVANT DE DÉMARRER LE MOTEUR.

VÉRIFIER LE SENS DE ROTATION DU MOTEUR (DANS LE SENS DES AIGUILLES D'UNE MONTRE EN REGARDANT VERS LE BAS DU DESSUS DU MOTEUR).

2. POMPES VERTICALES EN LIGNE MONTÉES AU SOL

Les grosses pompes FLO FAB de type Vertical En Ligne et toutes les pompes de type split coupled comportent des bases de support sous le corps de pompe. Ces pompes doivent être montées au sol.

LA POMPE DOIT ÊTRE APPUYÉE AU SOL ET SOUDEMENT FIXÉE.

LA TUYAUTERIE NE DOIT PAS SUPPORTER LA POMPE, DES JOINTS FLEXIBLES DOIVENT ÊTRE UTILISÉS AUX CONNEXION D'ASPIRATION ET DE REFOULEMENT DE LA POMPE.

LA POMPE PEUT ÊTRE FIXÉE SUR UNE BASE D'INERTIE MONTÉE SUR RESSORTS.

CETTE MÉTHODE EST SURTOUT APPLICABLE POUR LES POMPE À FORT HP

Bien que les pompes Verticales En Ligne ne vibrent pas, il est recommandé, pour celles montées au sol, de prévoir des dispositifs d'isolation entre la base d'inertie et la structure de fondation ainsi que des raccords flexibles sur les tuyauteries adjacentes à ces pompes. Il est important de ne jamais combiner les deux méthodes de montage. Si tel était le cas, un stress important serait appliqué sur le corps de la pompe et pourrait entraîner un bris. Ces méthodes relèvent de l'institut de l'hydraulique et FLO FAB peut confirmer que les autres manufacturiers tels que Darling, Plad et Bell & Gossett font les mêmes recommandations.

Instruction pour l'installation de valve MFV

Si vous utilisez le MFV comme une vanne d'équilibrage, vous devez avoir installé en amont 10 fois la taille du diamètre du tuyau pour maintenir la précision. Si le MFV est uniquement utilisé comme d'une vanne d'étranglement, d'un clapet de non-retour, et d'une vanne d'isolement, seulement 5 fois le diamètre du tuyau est requis après la pompe de décharge. Après le système d'équilibrage, si c'est une vanne primaire et ouvert à moins de 50%, les standards ASHREA 90.1 et Flo Fab recommande de reduire le diametre de l'impluseur jusqu'au point de débit requis. Cela permettra de réduire la consommation d'électricité et de se conformer à la norme de l'office national de l'énergie du Code du bâtiment. Pour éviter les problèmes de bruit et endommager la valve, ne pas dépasser 25 pieds lors de la chute de pression dans le MFV.

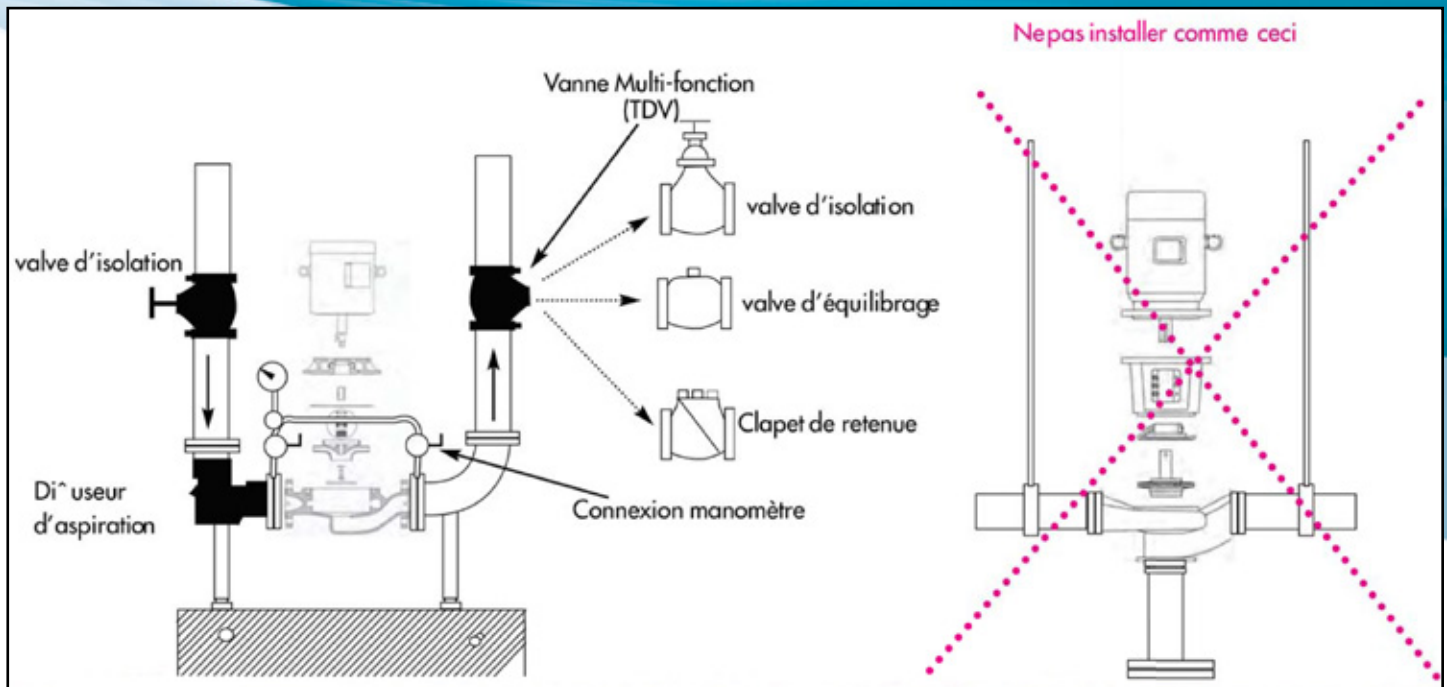

OPÉRATION

GROUPE ELECTRO-POMPE

1. Avant le raccordement du moteur et du démarreur au réseau;
 - 1.1. Prendre connaissance du schéma de raccordement contenu dans le boîtier du moteur.
 - 1.2. Vérifier si la tension et la fréquence du réseau concordent avec celles mentionnées sur la plaque du moteur.
 - 1.3. Vérifier si l'ampérage des relais de protection et des fusibles concordent avec l'ampère à pleine charge mentionné sur la plaque du moteur.
2. Vérifier le graissage et les garnitures du presse-étoupe (voir ENTRETIEN),
3. Voir à ce que le rotor du moteur et le mobile de la pompe tournent facilement à la main. Si cela semble frotter même légèrement, retarder la mise en marche jusqu'à ce que la couse en soit découverte et que les corrections y soient apportées.
4. Pour les unités équipés de variateur de vitesse hydraulique, consulter le manuel d'instruction du variateur.
5. Pour les pompes de circulation d'eau surchauffée, consulter les instructions spécifiques à ces pompes.
6. Amorcer la pompe par remplissage de la volute et de la conduite d'aspiration. En ouvrant les purgeurs d'air, l'air est naturellement expulsée. Tourner à la main la pompe de quelques tours pour faire sortir l'air qui aurait pu s'accumuler dans les concavités. Le remplissage est terminé lorsque les purgeurs refoulent de l'eau sans bulles d'air. Pour les installations en dépression sans clapet de pied, l'amorçage est réalisé par le vide à l'aide d'un éjecteur ou d'une pompe à vide.
7. Lancer le moteur de quelques tours, pour vérifier que le sens de rotation est correct: il est indiqué par une flèche sur la volute.
8. Mettre le moteur en marche et, aussitôt la vitesse normale atteinte, vérifier à l'aide d'un ampèremètre que l'intensité maximum inscrite sur la plaque du moteur n'est pas dépassée, compte tenu du facteur de service.

ATTENTION

- A. S'ASSURER QUE LE ROBINET-VANNE D'ASPIRATION EST GRAND OUVERT CAR UN ÉTRANGLEMENT DE CE CÔTÉ EST DANGEREUX POUR LA POMPE.
- B. S'ASSURER QUE LA POMPE NE COURT AUCUNE CHANCE DE FONAIIONNER À SEC CAR LA PLUPART DES POMPES CENTRIFUGES ONT DE FAIBLES TOLÉRANCES ET NE PEUVENT EN AUCUN CAS TOURNER À SEC SANS QU'IL S'ENSUIVE DE SÉRIEUX DOMMAGES.

ENTRETIEN

Une vérification systématique, exécutée à intervalles réguliers selon les recommandations suivantes vous assurera de nombreuses années de fonctionnement satisfaisant.

PRÉCAUTIONS GÉNÉRALES

1. Maintenir l'unité en état de propreté.
2. Éviter la tension excessive des courroies.
3. Munir le moteur d'une protection adéquate contre les surcharges.
4. Eviter que des particules étrangères ne viennent virevolter près des ouvertures d'aération du moteur.
5. Eviter de faire fonctionner le groupe dans une atmosphère surchauffée.
6. Eviter qu'un moteur triphasé ne fonctionne sur une seule phase; ceci s'accompagne d'un bourdonnement caractéristique, d'une perte de vitesse et d'un échauffement excessif aboutissant rapidement à la destruction des enroulements.
7. Se servir de thermomètres pour vérifier les températures.
8. Dans le cas d'arrêt dans une atmosphère à basse température, vidanger les conduites d'aspiration et de refoulement ainsi que la pompe.

PALIER

1. Les paliers lubrifiés à vie sont d'un type robuste, étanche et leur lubrification permanente évite tout entretien.
2. Les paliers lubrifiés à la graisse demandent très peu d'attention. Garnir de graisse (Esso Andok No. 280 ou équivalent) une fois par mois (selon le service), mais sans excès pour éviter le coulage et l'échauffement pouvant endommager les paliers. Enlever auparavant le bouchon d'excédent de graisse pour permettre à la vieille graisse de s'échapper.

LIMITE D'EMPLOI DES GARNITURES MÉCANIQUES

Les pompes standard FLO FAB sont équipées de garnitures mécaniques. Les garnitures mécaniques standard sont munies de siège en NI-resist, de rondelle de carbone et de soufflet de Viton. Les limites recommandées pour les températures et pressions.

HP ET VITESSE DU MOTEUR	PRESSION D'ASPIRATION (PSIG)	TEMPÉRATURE MAXIMUM (°F)
Jusqu'à 10HP 1750 RPM	60	250
	85	225
	125	160
15 - 50HP 1750 RPM	50	250
	60	225
	100	160
Jusqu'à 15HP 3500 RPM	20	180
	125	120
20 - 60HP 3500 RPM	15	180
	115	120

ATTENTION

- A. UNE GARNITURE MÉCANIQUE EST UNE PIÈCE DE PRÉCISION: ELLE DOIT ÊTRE MANIPULÉE AVEC SOIN. LA COUPELLE ET SON SIÈGE NÉCESSITENT UNE ATTENTION TOUTE PARTICULIÈRE. ON NE DOIT PAS LES LAISSER TOMBER PAR TERRE ET LES SURFACES DE CONTACT DOIVENT ÊTRE EXEMPTÉ DE TOUTE ÉRAFLURE.
- B. NE JAMAIS FAIRE TOURNER UNE GARNITURE MÉCANIQUE À SEC.
- C. SUIVRE LES INSTRUCTIONS DU FABRICANT DE LA GARNITURE MÉCANIQUE.

ENTRETIEN PRÉVENTIF

1. Protéger la pompe à l'aide d'un filtre convenable.
2. Ne jamais pomper un liquide pour lequel la pompe n'a pas été conçue (se renseigner auprès de votre représentant(e) FLO FAB).
3. Maintenir la quantité requise du lubrifiant recommandé en suivant à la lettre les instructions de graissage.
4. Vérifier périodiquement l'alignement de la ligne d'arbre.
5. Corriger toute contrepente des tuyaux d'aspiration vers la pompe.
6. S'assurer qu'aucun effort n'est supporté par la volute.
7. Ne jamais faire tourner une pompe à sec,
8. Vérifier périodiquement l'état des bagues d'usure.
9. Remplacer immédiatement les chemises d'arbres si elles comportent de fortes rayures.
10. Si le liquide pompé est chargé de particules en suspension, utiliser une source extérieure pour alimenter les garnitures.
11. Un plan de routine d'entretien doit être établi pour s'assurer des visites d'inspection et d'entretien indispensables pour tirer de vos unités de pompage le meilleur service.

ENTRETIEN DES POMPES VERTICALES EN LIGNE

Les pompes de type Verticales sont conçues pour fonctionner sans aucun entretien périodique autre que le graissage des paliers du moteur avec une graisse au silicone telle que Dow-Corning 44, Keystone No. 89 ou Supermill ASU 06752, une seule fois tous les trois (3) mois. La durée de la pompe et son bon fonctionnement dépendent d'une sélection adéquate, d'une installation convenable et de la lubrification continue de la garniture mécanique. Le bouchon d'évent doit être dévissé pour purger entièrement l'air du corps de pompe avant la mise en route afin d'assurer la lubrification de la garniture mécanique. Les particules en suspension dans le réseau raccourciront toujours la durée des garnitures mécaniques à cause de leurs propriétés abrasives. Les particules les plus courantes sont celles d'oxyde de fer (FE304) qui, hautement magnétiques, ont tendance à former une croûte sur toute la surface en contact avec l'eau est un facteur important de la durée de la garniture mécanique. Il est recommandé de limiter les chromâtes en suspension dans l'eau à 250 ppm.

DÉMONTAGE DES POMPES 880

Il est inutile de démonter la tuyauterie pour accéder aux pompes de Type V, VI, RI et SC. Le service et l'entretien peut être effectué en soulevant l'élément rotatif hors du corps de pompe.

1. Débrancher les fils du moteur.
2. Démontez les boulons retenant le support du moteur au corps de pompe et l'ensemble rotatif peut être retiré du corps de pompe en soulevant le moteur, tel qu'indiqué.
3. Retirez l'écrou de blocage de l'impulseur en tournant dans le sens contraire des aiguilles d'une montre. Sortez l'impulseur en le soulevant avec des coins tout autour et retirez la clé de l'impulseur de son chemin de clé.
4. Faire glisser hors de l'arbre la coupole rotative de la garniture mécanique.
5. Démontez les boulons retenant le moteur à son support.
6. Pour remplacer les bagues d'usure, coupez celles-ci au ciseau pour les retirer et placez les bagues neuves après les avoir légèrement huilées et en les poussant par petits coups à l'aide d'un marteau de plomb.
7. Pour remplacer la chemise d'arbre, il est important de n'appliquer aucune pression sur les paliers du moteur.

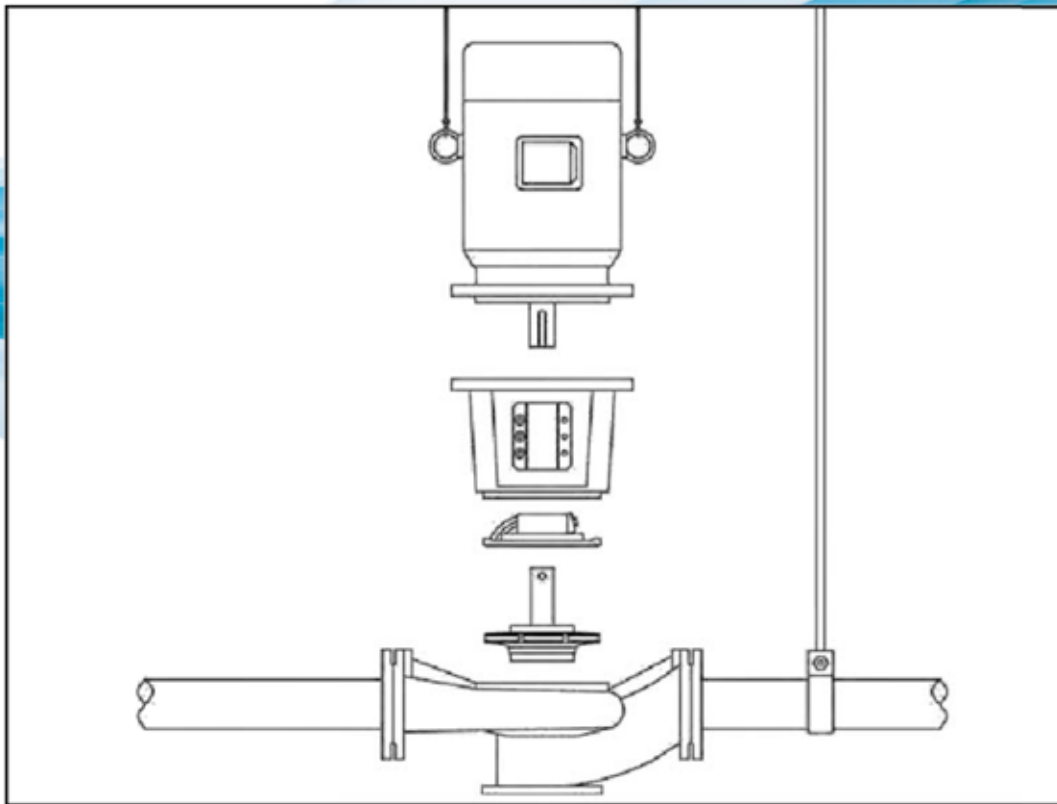

FIGURE V - TYPE 880

REMONTAGE

1. Nettoyer le logement du support du moteur avant d'y placer le siège de la garniture mécanique et sa coupole rotative, tous deux légèrement lubrifiés.
2. Boulonner le moteur à son support en prenant soin de ne pas cogner l'arbre du moteur à la garniture mécanique.
3. Remettre la clé de l'impulseur dans son chemin sur l'arbre. Glisser la garniture mécanique et son ressort sur l'arbre puis l'impulseur.
4. Visser l'écrou de blocage de l'impulseur dans le sens des aiguilles d'une montre et le bloquer en place.
5. Retirer le joint du corps de pompe et nettoyer son assise sur le corps de pompe et sur le support du moteur. Placer un joint neuf sur ce dernier.
6. Descendre l'ensemble rotatif dans le corps de pompe en centrant soigneusement l'impulseur pour éviter de l'endommager. Resserrer progressivement les boulons tout autour.
7. Remplir le corps de pompe d'eau et le purger de son air par l'évent.
8. Rebrancher les fils au moteur. Vérifier le sens de rotation pour s'assurer d'un fonctionnement convenable.

DÉMONTAGE DES POMPES TYPE 880

Le service et l'entretien régulier des pompes Type 880 peuvent être effectués sans toucher ni au moteur ni à l'ensemble rotatif.

1. Dévisser les boulons des plateaux de l'accouplement flexible et retirer la partie centrale (entretoise).
2. Retirer le plateau inférieur de l'accouplement flexible puis l'écrou du boîtier de palier, la rondelle et les boulons puis soulever le boîtier de palier.
3. Retirer le boîtier de la garniture. Lorsque la garniture mécanique seule doit être démontée, l'ensemble des boîtiers de palier et de la garniture peuvent être soulevés comme une seule cartouche en enlevant les deux boulons traversant le boîtier de la garniture.
4. Retirer pour inspection, si nécessaire, le palier inférieur et son porte-palier en démontant les boulons de fixations.
5. Pour les réparations majeures où l'élément rotatif doit être retiré, démonter l'accouplement, soulever le moteur et retirer les boulons de palier et de garniture mécanique. Enlever le support du moteur et le couvercle supérieur du corps de pompe avant de sortir l'ensemble rotatif.

PIÈCES DE RECHANGE

L'application particulière détermine, en grande partie, le nombre minimum de pièces de rechange dont on doit disposer sur place. Un jeu minimum de pièces doit comporter :

- Un jeu d'anneaux d'usure.
- Un jeu de chemises d'arbre pour les arbres chemisés.
- Un orbrede couche pour les arbres non chemisés.
- De la tresse pour une garniture mécanique complète.
- Des feuilles à joint,

En commandant des pièces de rechange. Indiquer toujours le numéro de série de la pompe et donner une description complète de la pièce désirée.

WARRANTY

Les pompes FLO FAB sont garanties contre tout défaut de fabrication pour une durée de 12 mois à partir de la date d'expédition du manufacturier. En cas de défectuosité durant cette période, notre responsabilité se limite à la réparation ou au remplacement des pièces défectueuses qui doivent être retournées en usine, port payé. Nous n'acceptons aucune responsabilité pour les dégâts ou dommages dus à des motifs hors de notre contrôle ou résultant d'une usure normale, ni pour des réparations faites ou tentées d'être faites sans notre consentement, ni pour aucun dommage résultant d'un défaut de fonctionnement d'une pompe. Que ce soit pour un remplacement ou pour un ajustement de la pièce défectueuse, les frais de main d'oeuvre seront toujours à la charge du client.

Veillez noter que notre garantie **NE COUVRE PAS** le joint d'étanchéité mécanique.

TABLEAU DE DÉPANNAGE

(voir légende à la page suivante)

SYMPTÔMES	CAUSES POSSIBLES
La pompe ne refoule pas	1, 2, 3, 4, 6, 11, 14, 16, 17, 22, 23
Insuffisance de débit	2, 3, 4, 5, 6, 7, 8, 9, 10, 11, 14, 17, 20, 22, 23, 29, 30, 31
Pression insuffisante	5, 14, 16, 18, 19, 20, 23, 24, 26, 27, 29, 33, 34, 37
Désamorçage de la pompe après démarrage	2, 3, 5, 6, 7, 8, 11, 12, 13
Ampérage excessif	15, 16, 18, 19, 20, 23, 24, 26, 27, 29, 33, 34, 37
Échauffement du presse-étoupe	24, 26, 32, 33, 34, 35, 36, 38, 39, 40
Les tresses de garniture ne durent pas	12, 13, 24, 26, 28, 32, 33, 34, 35, 36, 37, 38, 39, 40
La pompe vibre ou est bruyante	2, 3, 4, 9, 10, 11, 21, 23, 24, 25, 26, 27, 28, 30, 35, 36, 41, 42, 43, 44, 45, 46, 47
Les paliers ne durent pas	24, 26, 27, 28, 35, 36, 41, 42, 43, 44, 45, 46, 47
La pompe surchauffe et grippe	1, 4, 21, 22, 24, 27, 28, 35, 36, 41

LÉGENDE

DÉFAUTS À L'ASPIRATION

1. Amorçage manqué.
2. Pompe et tuyau d'aspiration incomplètement remplis de liquide.
3. Hauteur d'aspiration trop grande.
4. Marge insuffisante entre la pression d'aspiration et la tension de vapeur (NPSH disponible trop bas).
5. Liquide contenant trop d'air ou de gaz.
6. Poche d'air dans la ligne d'aspiration.
7. Rentrées d'air à l'aspiration.
8. Rentrées d'air au presse-étoupe.
9. Clapet de pied de dimension insuffisante.
10. Crépine obstruée.
11. Extrémité du tuyau d'aspiration insuffisamment immergé.
12. Canal d'alimentation de lanterne obstrué.
13. Lanterne mal placée dans le presse-étoupe, prévenant l'arrivée de liquide.

DÉFAUTS DU SYSTÈME

14. Vitesse insuffisante.
15. Vitesse excessive.
16. Mauvais sens de rotation.
17. Hauteur d'élévation supérieure à la pression développée par la pompe.
18. Hauteur d'élévation inférieure à la pression développée par la pompe.

19. Densité du liquide différente de celle spécifiée.
20. Viscosité du liquide différente de celle spécifiée.
21. Fonctionnement à débit très bas.
22. Fonctionnement en parallèle de pompes non assorties.

DÉFAUTS MÉCANIQUES

23. Roue obstruée.
24. Mauvais alignement.
25. Manque de rigidité de la fondation.
26. Arbre faussé.
27. Rotor frottant à la volute.
28. Paliers usés.
29. Bagues d'usure usées.
30. Roue endommagée.
31. Joint de volute non étanche d'où fuite interne.
32. Arbre ou chemise d'arbre usé ou éraflé au presse-étoupe.
33. Garniture mal posée.
34. Type de tresse ne convenant pas à l'application.
35. Arbre décentré à cause de l'usure des paliers ou d'un mauvais alignement.
36. Rotor mal équilibré déterminant des vibrations.
37. Garniture trop serrée empêchant le liquide d'alimenter la garniture.
38. Défaut de refroidissement de la garniture.
39. Tolérance excessive au fond du presse-étoupe laissant la tresse pénétrer dans la pompe,
40. Liquide d'alimentation de

la lanterne malpropre, entraînant l'éraflure de l'arbre ou de la chemise.

41. Poussée axiale excessive due à un défaut mécanique de la pompe ou du dispositif d'équilibre hydraulique s'il y en a un.

42. Défaut de lubrification.

43. Manque de lubrifiant.

44. Installation incorrecte des paliers à douille (dommage pendant la mise en place).

45. Paliers encrassés.

46. Paliers rouillés dû à une infiltration d'eau dans leur boîtier.

47. Refroidissement excessif des paliers déterminant une condensation, dans le boîtier, de l'humidité de l'atmosphère.

SÉRIES 880 PARTS LIST

Vertical In-line Pump Parts Series 880				
**	#	Parts	Standard	Options
	1	Motor	----	----
X	2	Motor Shaft Key	Carbon Steel - 1045	Bronze ASTM B584C87500
	3	Adaptor	Cast Iron ASTM A48CL30	Bronze ASTM B584C87500
	4	Air Vent Plug	----	----
X	5	Shaft Sleeve	Bronze ASTM B584C87500	Stainless Steel 18-8 Open Designation
X	6	Mechanical Seal	Viton/Ceramics Carbon w/ Stainless Steel Spring	Various (for assembly)
	7	Impeller	Bronze ASTM B584C87500	Cast Iron ASTM A48CL30
	8	Impeller Washer	Stainless Steel 18-8 Open Designation	----
	9	Impeller Bolt	Stainless Steel 18-8 Open Designation	----
X	10	Casing Gasket	Fiber Gasket (Vellumoid)	----
X	11	Wear Rings	Bronze ASTM B584C87500	Stainless Steel 18-8 Open Designation
	12	Casing	Cast Iron ASTM A48CL30	----

***Recommended Spare Parts

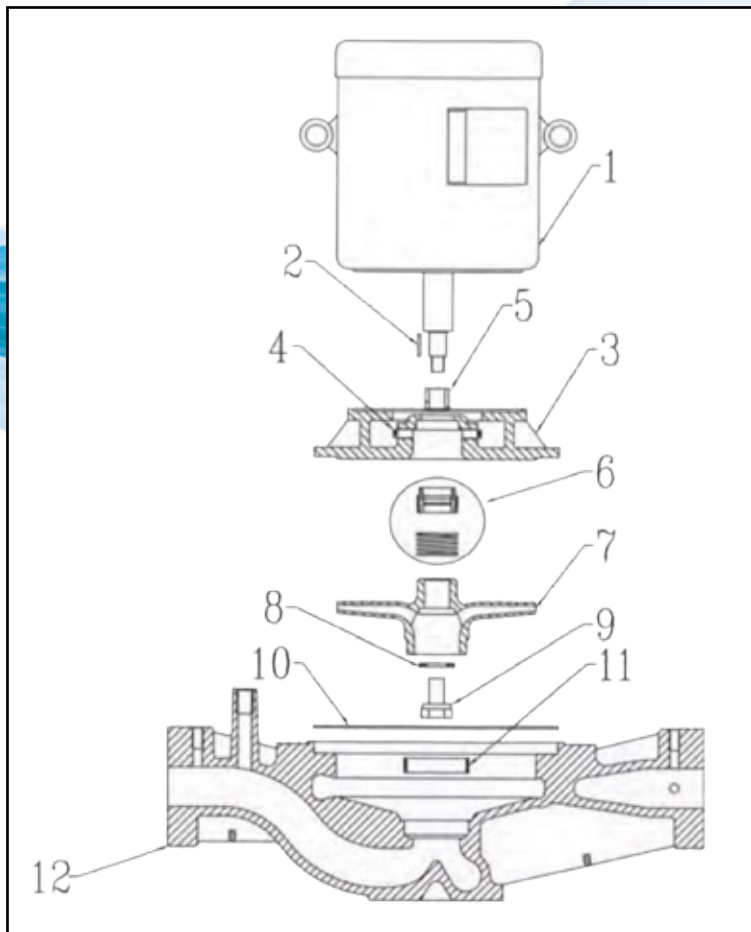

SERIES 880 PARTS LIST

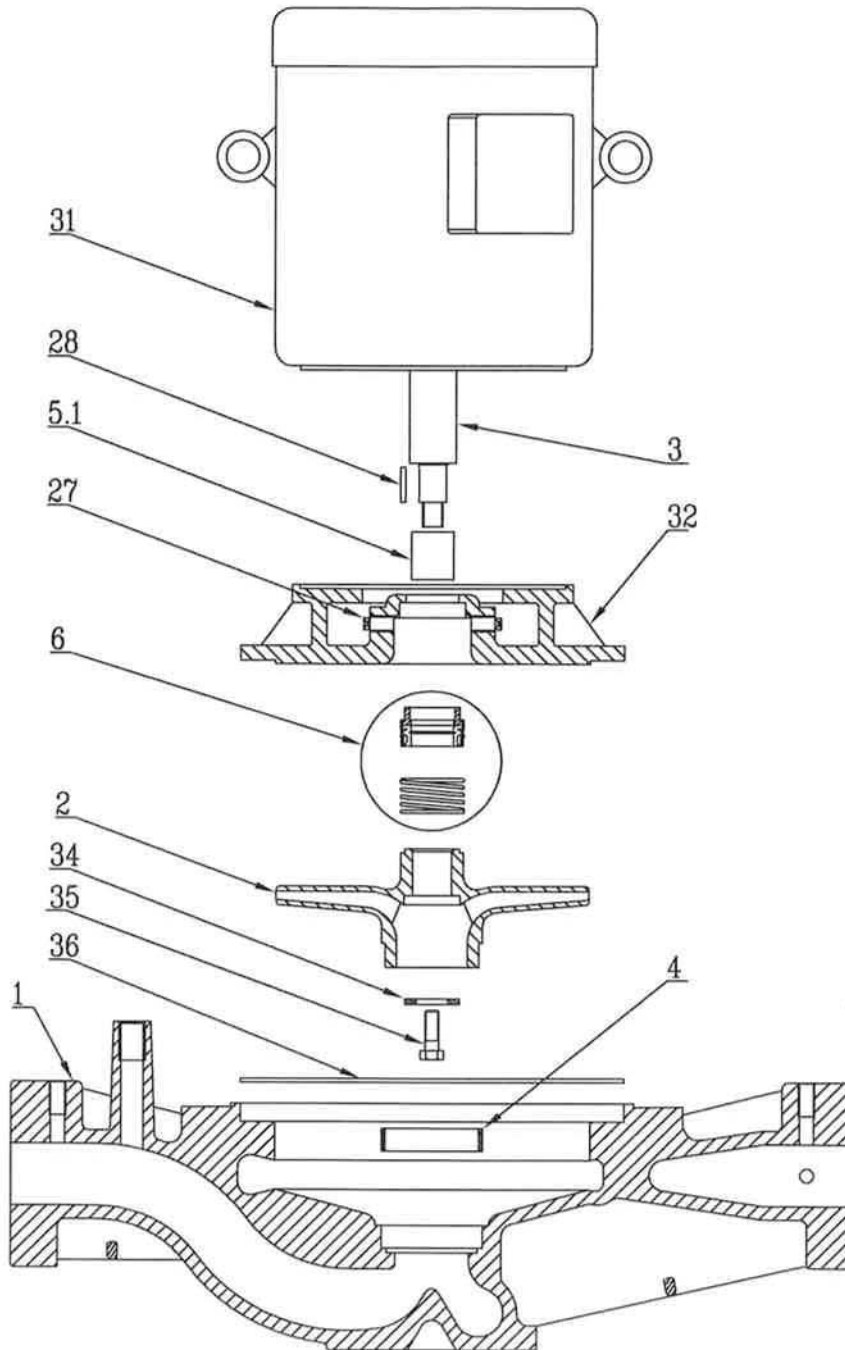

SERIAL # : _____

TYPE : _____

ID. : _____

SERIES : 880

MODEL : _____

DATE : 03-05-2011





* Series	recommended spares						
NO	PART NAME	PART NUMBER	STANDARD MATERIAL	PART NUMBER	OPTIONAL MATERIAL		
1	volute casing	2687414	cast iron ASTMA48CL 30	2687414-B	bronze ASTM584C87400		
1.1	volute casing			2687414-SS	stainless steel 304		
1.2	volute casing			2687414-DI	ductile iron 300 PSI GGG50		
1.3	volute casing			2687414-CS	cast steel ASTMA216WCB		
*2.1	impeller 7/8	V1735-449	bronze ASTM584C87400	V1735-491	cast iron ASTMA48CL30		
*2.2	impeller 7/8			V1735-SS	stainless steel 304		
*2.3	impeller 1 1/4	V3289-449	bronze ASTM584C87400	V3289-491	cast iron ASTMA48CL30		
*2.4	impeller 1 1/4			V3289-SS	stainless steel 304		
3	motor shaft		carbon steel 4340 clear zinc plated				
*4	casing wearing	2684006	bronze ASTM584C87400	2684006-SS	stainless steel 18-8 open designation		
*5.1	shaft sleeve 143-215	SLJM1.250B	bronze ASTM584C87400	SLJM1.250SS	stainless steel 18-8 open designation		
*5.2	shaft sleeve 354-326	SLJM1.500B	bronze ASTM584C87400	SLJM1.500SS	stainless steel 18-8 open designation		
*6.1	mechanical seal 143-215	011-S125-21-per	viton/ceramic vs carbon w/stainless steel spring	011-S125-dirt	viton/silicone carbide w/stainless steel		
*6.2	mechanical seal 354-326	011-S150-21-per	viton/ceramic vs carbon w/stainless steel spring	011-S150-dirt	viton/silicone carbide w/stainless steel		
27	air vent valve plug						
28	impeller key		carbon steel ASTMA108G10800				
31	motor						
32.1	bracket 143-215	2683879	cast iron ASTMA48CL 30	2683879-B	bronze ASTM584C87400		
32.2	bracket 143-215			2683879-SS	stainless steel 304		
32.3	bracket 143-215			2683879-DI	ductile iron 300 PSI GGG50		
32.4	bracket 143-215			2683879-CS	cast steel ASTMA216WCB		
32.5	bracket 254-256	2683880	cast iron ASTMA48CL 30	2683880-B	bronze ASTM584C87400		
32.6	bracket 254-256			2683880-SS	stainless steel 304		
32.7	bracket 254-256			2683880-DI	ductile iron 300 PSI GGG50		
32.8	bracket 254-256			2683880-CS	cast steel ASTMA216WCB		
32.9	bracket 284-326	2683882	cast iron ASTMA48CL 30	2683882-B	bronze ASTM584C87400		
32.10	bracket 284-326			2683882-SS	stainless steel 304		
32.11	bracket 284-326			2683882-DI	ductile iron 300 PSI GGG50		
32.12	bracket 284-326			2683882-CS	cast steel ASTMA216WCB		
33	motor shaft key		carbon steel - 1045		stainless steel 18-8 open designation		
34.1	impeller washer no 1	WF1-SS	stainless steel 18-8 open designation				
34.2	impeller washer no 2	WF2-SS	stainless steel 18-8 open designation				
35.1	impeller bolt no 1	LBF1-SS	stainless steel 18-8 open designation				
35.2	impeller bolt no 2	LBF2-SS	stainless steel 18-8 open designation				
*36	casing gasket	G-8P	fiber gasket vellumoid				
37	motor bolts		carbon steel				



* NO	recommended spares	PART NUMBER	STANDARD MATERIAL	PART NUMBER	OPTIONAL MATERIAL
1	volute casing	2687418	cast iron ASTMA48CL 30	2687418-B	bronze ASTMB584C87400
1.1	volute casing			2687418-SS	stainless steel 304
1.2	volute casing			2687418-DI	ductile iron 300 PSI GGG50
1.3	volute casing			2687418-CS	cast steel ASTMA216WCB
*2.1	impeller 7/8	2683739-449	bronze ASTMB584C87400	2683739-491	cast iron ASTMA48CL30
*2.2	impeller 7/8			2683739-SS	stainless steel 304
*2.3	impeller 1 1/4	2683747-449	bronze ASTMB584C87500	2683747-491	cast iron ASTMA48CL30
*2.4	impeller 1 1/4			2683747-SS	stainless steel 304
3	motor shaft		carbon steel 4340 clear zinc plated		
*4	casing wearing	V1811	bronze ASTMB584C87400	V1811-SS	stainless steel 18-8 open designation
*5.1	shaft sleeve 143-215	SLJM1.250B	bronze ASTMB584C87400	SLJM1.250SS	stainless steel 18-8 open designation
*5.2	shaft sleeve 354-326	SLJM1.500B	bronze ASTMB584C87400	SLJM1.500SS	stainless steel 18-8 open designation
*6.1	mechanical seal 143-215	011-S125-21-per	viton/ceramic vs carbon w/stainless steel spring	011-S125-dirt	viton/silicone carbide w/stainless steel
*6.2	mechanical seal 354-326	011-S150-21-per	viton/ceramic vs carbon w/stainless steel spring	011-S150-dirt	viton/silicone carbide w/stainless steel
27	air vent valve plug				
28	impeller key		carbon steel ASTMA108G10800		
31	motor				
32.1	bracket 143-215	2683879	cast iron ASTMA48CL 30	2683879-B	bronze ASTMB584C87400
32.2	bracket 143-215			2683879-SS	stainless steel 304
32.3	bracket 143-215			2683879-DI	ductile iron 300 PSI GGG50
32.4	bracket 143-215			2683879-CS	cast steel ASTMA216WCB
32.5	bracket 254-256	2683880	cast iron ASTMA48CL 30	2683880-B	bronze ASTMB584C87400
32.6	bracket 254-256			2683880-SS	stainless steel 304
32.7	bracket 254-256			2683880-DI	ductile iron 300 PSI GGG50
32.8	bracket 254-256			2683880-CS	cast steel ASTMA216WCB
32.9	bracket 284-326	2683882	cast iron ASTMA48CL 30	2683882-B	bronze ASTMB584C87400
32.10	bracket 284-326			2683882-SS	stainless steel 304
32.11	bracket 284-326			2683882-DI	ductile iron 300 PSI GGG50
32.12	bracket 284-326			2683882-CS	cast steel ASTMA216WCB
33	motor shaft key		carbon steel - 1045		stainless steel 18-8 open designation
34.1	impeller washer no 1	WF1-SS	stainless steel 18-8 open designation		
34.2	impeller washer no 2	WF2-SS	stainless steel 18-8 open designation		
35.1	impeller bolt no 1	LBF1-SS	stainless steel 18-8 open designation		
35.2	impeller bolt no 2	LBF2-SS	stainless steel 18-8 open designation		
*36	casing gasket	G-8P	fiber gasket vellumoid		
37	motor bolts		carbon steel		



* NO	recommended spares	PART NUMBER	STANDARD MATERIAL	PART NUMBER	OPTIONAL MATERIAL
Series 880	model A X 4 X 8				
1	volute casing	2687420	cast iron ASTMA48CL 30	2687420-B	bronze ASTMB584C87400
1.1	volute casing			2687420-SS	stainless steel 304
1.2	volute casing			2687420-DI	ductile iron 300 PSI GGG50
1.3	volute casing			2687420-CS	cast steel ASTMA216WCB
*2.1	impeller 7/8	2680864-449	bronze ASTMB584C87400	2680864-491	cast iron ASTMA48CL30
*2.2	impeller 7/8			2680864-SS	stainless steel 304
*2.3	impeller 1 1/4	2680863-449	bronze ASTMB584C87400	2680863-491	cast iron ASTMA48CL30
*2.4	impeller 1 1/4			2680863-SS	stainless steel 304
3	motor shaft		carbon steel 4340 clear zinc plated		
*4	casing wearing	2691670	bronze ASTMB584C87400	2691670-SS	stainless steel 18-8 open designation
*5.1	shaft sleeve 143-215	SLJM1.250B	bronze ASTMB584C87400	SLJM1.250SS	stainless steel 18-8 open designation
*5.2	shaft sleeve 354-326	SLJM1.500B	bronze ASTMB584C87400	SLJM1.500SS	stainless steel 18-8 open designation
*6.1	mechanical seal 143-215	011-S125-21-per	viton/ceramic vs carbon w/stainless steel spring	011-S125-dirt	viton/silicone carbide w/stainless steel
*6.2	mechanical seal 354-326	011-S150-21-per	viton/ceramic vs carbon w/stainless steel spring	011-S150-dirt	viton/silicone carbide w/stainless steel
27	air vent valve plug				
28	impeller key		carbon steel ASTMA108G10800		
31	motor				
32.1	bracket 143-215	2683879	cast iron ASTMA48CL 30	2683879-B	bronze ASTMB584C87400
32.2	bracket 143-215			2683879-SS	stainless steel 304
32.3	bracket 143-215			2683879-DI	ductile iron 300 PSI GGG50
32.4	bracket 143-215			2683879-CS	cast steel ASTMA216WCB
32.5	bracket 254-256	2683880	cast iron ASTMA48CL 30	2683880-B	bronze ASTMB584C87400
32.6	bracket 254-256			2683880-SS	stainless steel 304
32.7	bracket 254-256			2683880-DI	ductile iron 300 PSI GGG50
32.8	bracket 254-256			2683880-CS	cast steel ASTMA216WCB
32.9	bracket 284-326	2683882	cast iron ASTMA48CL 30	2683882-B	bronze ASTMB584C87400
32.10	bracket 284-326			2683882-SS	stainless steel 304
32.11	bracket 284-326			2683882-DI	ductile iron 300 PSI GGG50
32.12	bracket 284-326			2683882-CS	cast steel ASTMA216WCB
33	motor shaft key		carbon steel - 1045		stainless steel 18-8 open designation
34.1	impeller washer no 1	WF1-SS	stainless steel 18-8 open designation		
34.2	impeller washer no 2	WF2-SS	stainless steel 18-8 open designation		
35.1	impeller bolt no 1	LBF1-SS	stainless steel 18-8 open designation		
35.2	impeller bolt no 2	LBF2-SS	stainless steel 18-8 open designation		
*36	casing gasket	G-8P	fiber gasket vellumoid		
37	motor bolts		carbon steel		



* recommended spares							
Series 280 Model 2 X 2 X 10							
NO	PART NAME	PART NUMBER	STANDARD MATERIAL	PART NUMBER	OPTIONAL MATERIAL		
1	volute casing	2687422	cast iron ASTMA48CL 30	2687422-B	bronze ASTM584C87400		
1.1	volute casing			2687422-SS	stainless steel 304		
1.2	volute casing			2687422-DI	ductile iron 300 PSI GGG50		
1.3	volute casing			2687422-CS	cast steel ASTMA216WCB		
*2.1	impeller 7/8	2680869-449	bronze ASTM584C87400	2680869-491	cast iron ASTMA48CL30		
*2.2	impeller 7/8			2680869-SS	stainless steel 304		
*2.3	impeller 1 1/4	2680870-449	bronze ASTM584C87400	2680870-491	cast iron ASTMA48CL30		
*2.4	impeller 1 1/4			2680870-SS	stainless steel 304		
3	motor shaft		carbon steel 4340 clear zinc plated				
*4	casing wearing	2684006	bronze ASTM584C87400	2684006-SS	stainless steel 18-8 open designation		
*5.1	shaft sleeve 143-215	SLJM1.250B	bronze ASTM584C87400	SLJM1.250SS	stainless steel 18-8 open designation		
*5.2	shaft sleeve 354-326	SLJM1.500B	bronze ASTM584C87400	SLJM1.500SS	stainless steel 18-8 open designation		
*6.1	mechanical seal 143-215	011-S125-21-per	viton/ceramic vs carbon w/stainless steel spring	011-S125-dirt	viton/silicone carbide w/stainless steel		
*6.2	mechanical seal 354-326	011-S150-21-per	viton/ceramic vs carbon w/stainless steel spring	011-S150-dirt	viton/silicone carbide w/stainless steel		
27	air vent valve plug						
28	impeller key		carbon steel ASTMA108G10800				
31	motor						
32.1	bracket 143-215	2683883	cast iron ASTMA48CL 30 F1	2683883-B	bronze ASTM584C87400		
32.2	bracket 143-215			2683883-SS	stainless steel 304		
32.3	bracket 143-215			2683883-DI	ductile iron 300 PSI GGG50		
32.4	bracket 143-215			2683883-CS	cast steel ASTMA216WCB		
32.5	bracket 254-256	2683884	cast iron ASTMA48CL 30 F2	2683884-B	bronze ASTM584C87400		
32.6	bracket 254-256			2683884-SS	stainless steel 304		
32.7	bracket 254-256			2683884-DI	ductile iron 300 PSI GGG50		
32.8	bracket 254-256			2683884-CS	cast steel ASTMA216WCB		
32.9	bracket 284-326	2691995	cast iron ASTMA48CL 30 F2	2691995-B	bronze ASTM584C87400		
32.10	bracket 284-326			2691995-SS	stainless steel 304		
32.11	bracket 284-326			2691995-DI	ductile iron 300 PSI GGG50		
32.12	bracket 284-326			2691995-CS	cast steel ASTMA216WCB		
33	motor shaft key		carbon steel - 1045		stainless steel 18-8 open designation		
34.1	impeller washer no 1	WF1-SS	stainless steel 18-8 open designation				
34.2	impeller washer no 2	WF2-SS	stainless steel 18-8 open designation				
35.1	impeller bolt no 1	LBF1-SS	stainless steel 18-8 open designation				
35.2	impeller bolt no 2	LBF2-SS	stainless steel 18-8 open designation				
*36	casing gasket	G-10P	fiber gasket vellumoid				
37	motor bolts		carbon steel				



* recommended spares							
Series 880 model 3 X 3 X 10							
NO	PART NAME	PART NUMBER	STANDARD MATERIAL	PART NUMBER	OPTIONAL MATERIAL		
1	volute casing	2687424	cast iron ASTMA48CL 30	2687424-B	bronze ASTMB584C87400		
1.1	volute casing			2687424-SS	stainless steel 304		
1.2	volute casing			2687424-DI	ductile iron 300 PSI GGG50		
1.3	volute casing			2687424-CS	cast steel ASTMA216WCB		
*2.1	impeller 7/8	2684314-449	bronze ASTMB584C87400	2684314-491	cast iron ASTMA48CL30		
*2.2	impeller 7/8			2684314-SS	stainless steel 304		
*2.3	impeller 1 1/4	2684354-449	bronze ASTMB584C87400	2684354-491	cast iron ASTMA48CL30		
*2.4	impeller 1 1/4			2684354-SS	stainless steel 304		
3	motor shaft		carbon steel 4340 clear zinc plated				
*4	casing wearing	V1810-brz	bronze ASTMB584C87400	V1810-SS	stainless steel 18-8 open designation		
*5.1	shaft sleeve 143-215	SLJM1.250B	bronze ASTMB584C87400	SLJM1.250SS	stainless steel 18-8 open designation		
*5.2	shaft sleeve 354-326	SLJM1.500B	bronze ASTMB584C87400	SLJM1.500SS	stainless steel 18-8 open designation		
*6.1	mechanical seal 143-215	011-S125-21-per	viton/ceramic vs carbon w/stainless steel spring	011-S125-dirt	viton/silicone carbide w/stainless steel		
*6.2	mechanical seal 354-326	011-S150-21-per	viton/ceramic vs carbon w/stainless steel spring	011-S150-dirt	viton/silicone carbide w/stainless steel		
27	air vent valve plug						
28	impeller key		carbon steel ASTMA108G10800				
31	motor						
32.1	bracket 143-215	2683883	cast iron ASTMA48CL 30 F1	2683883-B	bronze ASTMB584C87400		
32.2	bracket 143-215			2683883-SS	stainless steel 304		
32.3	bracket 143-215			2683883-DI	ductile iron 300 PSI GGG50		
32.4	bracket 143-215			2683883-CS	cast steel ASTMA216WCB		
32.5	bracket 254-256	2683884	cast iron ASTMA48CL 30 F2	2683884-B	bronze ASTMB584C87400		
32.6	bracket 254-256			2683884-SS	stainless steel 304		
32.7	bracket 254-256			2683884-DI	ductile iron 300 PSI GGG50		
32.8	bracket 254-256			2683884-CS	cast steel ASTMA216WCB		
32.9	bracket 284-326	2691995	cast iron ASTMA48CL 30 F2	2691995-B	bronze ASTMB584C87400		
32.10	bracket 284-326			2691995-SS	stainless steel 304		
32.11	bracket 284-326			2691995-DI	ductile iron 300 PSI GGG50		
32.12	bracket 284-326			2691995-CS	cast steel ASTMA216WCB		
33	motor shaft key		carbon steel - 1045		stainless steel 18-8 open designation		
34.1	impeller washer no 1	WF1-SS	stainless steel 18-8 open designation				
34.2	impeller washer no 2	WF2-SS	stainless steel 18-8 open designation				
35.1	impeller bolt no 1	LBF1-SS	stainless steel 18-8 open designation				
35.2	impeller bolt no 2	LBF2-SS	stainless steel 18-8 open designation				
*36	casing gasket	G-10P	fiber gasket vellumoid				
37	motor bolts		carbon steel				



* recommended spares					
NO	PART NAME	PART NUMBER	STANDARD MATERIAL	PART NUMBER	OPTIONAL MATERIAL
1	volute casing	2687426	cast iron ASTMA48CL 30	2687426-B	bronze ASTMB584C87400
1.1	volute casing			2687426-SS	stainless steel 304
1.2	volute casing			2687426-DI	ductile iron 300 PSI GGG50
1.3	volute casing			2687426-CS	cast steel ASTMA216WCB
*2.1	impeller 7/8	2684315-449	bronze ASTMB584C87400	2684315-491	cast iron ASTMA48CL30
*2.2	impeller 7/8			2684315-SS	stainless steel 304
*2.3	impeller 1 1/4	2684353-449	bronze ASTMB584C87400	2684353-491	cast iron ASTMA48CL30
*2.4	impeller 1 1/4			2684353-SS	stainless steel 304
3	motor shaft		carbon steel 4340 clear zinc plated		
*4	casing wearing	V1811	bronze ASTMB584C87400	V1811-SS	stainless steel 18-8 open designation
*5.1	shaft sleeve 143-215	SLJM1.250B	bronze ASTMB584C87400	SLJM1.250SS	stainless steel 18-8 open designation
*5.2	shaft sleeve 354-326	SLJM1.500B	bronze ASTMB584C87400	SLJM1.500SS	stainless steel 18-8 open designation
*6.1	mechanical seal 143-215	011-S125-21-per	viton/ceramic vs carbon w/stainless steel spring	011-S125-dirt	viton/silicone carbide w/stainless steel
*6.2	mechanical seal 354-326	011-S150-21-per	viton/ceramic vs carbon w/stainless steel spring	011-S150-dirt	viton/silicone carbide w/stainless steel
27	air vent valve plug				
28	impeller key		carbon steel ASTMA108G10800		
31	motor				
32.1	bracket 143-215	2683883	cast iron ASTMA48CL 30 F1	2683883-B	bronze ASTMB584C87400
32.2	bracket 143-215			2683883-SS	stainless steel 304
32.3	bracket 143-215			2683883-DI	ductile iron 300 PSI GGG50
32.4	bracket 143-215			2683883-CS	cast steel ASTMA216WCB
32.5	bracket 254-256	2683884	cast iron ASTMA48CL 30 F2	2683884-B	bronze ASTMB584C87400
32.6	bracket 254-256			2683884-SS	stainless steel 304
32.7	bracket 254-256			2683884-DI	ductile iron 300 PSI GGG50
32.8	bracket 254-256			2683884-CS	cast steel ASTMA216WCB
32.9	bracket 284-326	2691995	cast iron ASTMA48CL 30 F2	2691995-B	bronze ASTMB584C87400
32.10	bracket 284-326			2691995-SS	stainless steel 304
32.11	bracket 284-326			2691995-DI	ductile iron 300 PSI GGG50
32.12	bracket 284-326			2691995-CS	cast steel ASTMA216WCB
33	motor shaft key		carbon steel - 1045		stainless steel 18-8 open designation
34.1	impeller washer no 1	WF1-SS	stainless steel 18-8 open designation		
34.2	impeller washer no 2	WF2-SS	stainless steel 18-8 open designation		
35.1	impeller bolt no 1	LBF1-SS	stainless steel 18-8 open designation		
35.2	impeller bolt no 2	LBF2-SS	stainless steel 18-8 open designation		
*36	casing gasket	G-10P	fiber gasket vellumoid		
37	motor bolts		carbon steel		



* recommended spares							
Series 820 model 5X 5 X 10							
NO	PART NAME	PART NUMBER	STANDARD MATERIAL	PART NUMBER	OPTIONAL MATERIAL		
1	volute casing	2687430	cast iron ASTMA48CL 30	2687430-B	bronze ASTMB584C87400		
1.1	volute casing			2687430-BB	stainless steel 304		
1.2	volute casing			2687430-DI	ductile iron 300 PSI GGG50		
1.3	volute casing			2687430-CS	cast steel ASTMA216WCB		
*2.1	impeller 7/8	2691939-449	bronze ASTMB584C87400	2691939-491	cast iron ASTMA48CL30		
*2.2	impeller 7/8			2691939-SS	stainless steel 304		
*2.3	impeller 1 1/4	2689502-449	bronze ASTMB584C87400	2689502-491	cast iron ASTMA48CL30		
*2.4	impeller 1 1/4			2689502-SS	stainless steel 304		
3	motor shaft		carbon steel 4340 clear zinc plated				
*4	casing wearing	2691672	bronze ASTMB584C87400	2691672-SS	stainless steel 18-8 open designation		
*5.1	shaft sleeve 143-215	SLJM1.250B	bronze ASTMB584C87400	SLJM1.250SS	stainless steel 18-8 open designation		
*5.2	shaft sleeve 354-326	SLJM1.500B	bronze ASTMB584C87400	SLJM1.500SS	stainless steel 18-8 open designation		
*6.1	mechanical seal 143-215	011-S125-21-per	viton/ceramic vs carbon w/stainless steel spring	011-S125-dirt	viton/silicone carbide w/stainless steel		
*6.2	mechanical seal 354-326	011-S150-21-per	viton/ceramic vs carbon w/stainless steel spring	011-S150-dirt	viton/silicone carbide w/stainless steel		
27	air vent valve plug						
28	impeller key		carbon steel ASTMA108G10800				
31	motor						
32.1	bracket 143-215	2683883	cast iron ASTMA48CL 30 F1	2683883-B	bronze ASTMB584C87400		
32.2	bracket 143-215			2683883-SS	stainless steel 304		
32.3	bracket 143-215			2683883-DI	ductile iron 300 PSI GGG50		
32.4	bracket 143-215			2683883-CS	cast steel ASTMA216WCB		
32.5	bracket 254-256	2683884	cast iron ASTMA48CL 30 F2	2683884-B	bronze ASTMB584C87400		
32.6	bracket 254-256			2683884-SS	stainless steel 304		
32.7	bracket 254-256			2683884-DI	ductile iron 300 PSI GGG50		
32.8	bracket 254-256			2683884-CS	cast steel ASTMA216WCB		
32.9	bracket 284-326	2691995	cast iron ASTMA48CL 30 F2	2691995-B	bronze ASTMB584C87400		
32.10	bracket 284-326			2691995-SS	stainless steel 304		
32.11	bracket 284-326			2691995-DI	ductile iron 300 PSI GGG50		
32.12	bracket 284-326			2691995-CS	cast steel ASTMA216WCB		
33	motor shaft key		carbon steel - 1045		stainless steel 18-8 open designation		
34.1	impeller washer no 1	WF1-SS	stainless steel 18-8 open designation				
34.2	impeller washer no 2	WF2-SS	stainless steel 18-8 open designation				
35.1	impeller bolt no 1	LBF1-SS	stainless steel 18-8 open designation				
35.2	impeller bolt no 2	LBF2-SS	stainless steel 18-8 open designation				
*36	casing gasket	G-10P	fiber gasket vellumoid				
37	motor bolts		carbon steel				



* recommended spares							
Series	Model	Part Name	Part Number	Standard Material	Part Number	Optional Material	
1		volute casing	2687434	cast iron ASTMA48CL 30	2687434-B	bronze ASTMB584C87400	
1.1		volute casing			2687434-BB	stainless steel 304	
1.2		volute casing			2691991-DI	ductile iron 300 PSI GGG50	
1.3		volute casing			2691991-CS	cast steel ASTMA216WCB	
*2.1		impeller 1 1/4	2685595-449	bronze ASTMB584C87400	2689502-491	cast iron ASTMA48CL30	
*2.2		impeller 1 1/4			2689502-SS	stainless steel 304	
3		motor shaft		carbon steel 4340 clear zinc plated			
*4		casing wearing	2691672	bronze ASTMB584C87400	2691672-SS	stainless steel 18-8 open designation	
*5.1		shaft sleeve 143-215	SLJM1.250B	bronze ASTMB584C87400	SLJM1.250SS	stainless steel 18-8 open designation	
*5.2		shaft sleeve 354-326	SLJM1.500B	bronze ASTMB584C87400	SLJM1.500SS	stainless steel 18-8 open designation	
*6.1		mechanical seal 143-215	011-S125-21-per	viton/ceramic vs carbon w/stainless steel spring	011-S125-dirt	viton/silicone carbide w/stainless steel	
*6.2		mechanical seal 354-326	011-S150-21-per	viton/ceramic vs carbon w/stainless steel spring	011-S150-dirt	viton/silicone carbide w/stainless steel	
27		air vent valve plug					
28		impeller key		carbon steel ASTMA108G10800			
31		motor					
32.1		bracket 143-215	2683883	cast iron ASTMA48CL 30 F1	2683883-B	bronze ASTMB584C87400	
32.2		bracket 143-215			2683883-SS	stainless steel 304	
32.3		bracket 143-215			2683883-DI	ductile iron 300 PSI GGG50	
32.4		bracket 143-215			2683883-CS	cast steel ASTMA216WCB	
32.5		bracket 254-256	2683884	cast iron ASTMA48CL 30 F2	2683884-B	bronze ASTMB584C87400	
32.6		bracket 254-256			2683884-SS	stainless steel 304	
32.7		bracket 254-256			2683884-DI	ductile iron 300 PSI GGG50	
32.8		bracket 254-256			2683884-CS	cast steel ASTMA216WCB	
32.9		bracket 284-326	2691995	cast iron ASTMA48CL 30 F2	2691995-B	bronze ASTMB584C87400	
32.10		bracket 284-326			2691995-SS	stainless steel 304	
32.11		bracket 284-326			2691995-DI	ductile iron 300 PSI GGG50	
32.12		bracket 284-326			2691995-CS	cast steel ASTMA216WCB	
33		motor shaft key		carbon steel - 1045		stainless steel 18-8 open designation	
34.1		impeller washer no 1	WF1-SS	stainless steel 18-8 open designation			
34.2		impeller washer no 2	WF2-SS	stainless steel 18-8 open designation			
35.1		impeller bolt no 1	LBF1-SS	stainless steel 18-8 open designation			
35.2		impeller bolt no 2	LBF2-SS	stainless steel 18-8 open designation			
*36		casing gasket	G-8P	fiber gasket vellumoid			
37		motor bolts		carbon steel			



* recommended spares							
Series 330 model 4 X 4 X 12							
NO	PART NAME	PART NUMBER	STANDARD MATERIAL	PART NUMBER	OPTIONAL MATERIAL		
1	volute casing	2687428	cast iron ASTMA48CL 30	2687428-B	bronze ASTMB584C87400		
1.1	volute casing			2687428-SS	stainless steel 304		
1.2	volute casing			2687428-DI	ductile iron 300 PSI GGG50		
1.3	volute casing			2687428-CS	cast steel ASTMA216WCB		
*2.1	impeller 1 1/4	2685580-449	bronze ASTMB584C87400	2685580-491	cast iron ASTMA48CL30		
*2.2	impeller 1 1/4			2685580-SS	stainless steel 304		
3	motor shaft		carbon steel 4340 clear zinc plated				
*4	casing wearing	2691669	bronze ASTMB584C87400	2691669-SS	stainless steel 18-8 open designation		
*5.1	shaft sleeve 354-326	SLJM1.500B	bronze ASTMB584C87400	SLJM1.500SS	stainless steel 18-8 open designation		
*6.1	mechanical seal 354-326	011-S150-21-per	viton/ceramic vs carbon w/stainless steel spring	011-S150-dirt	viton/silicone carbide w/stainless steel		
27	air vent valve plug						
28	impeller key		carbon steel ASTMA108G10800				
31	motor						
32.1	bracket 143-215	2687811	cast iron ASTMA48CL 30 F1	2687811-B	bronze ASTMB584C87400		
32.2	bracket 143-215			2687811-SS	stainless steel 304		
32.3	bracket 143-215			2687811-DI	ductile iron 300 PSI GGG50		
32.4	bracket 143-215			2687811-CS	cast steel ASTMA216WCB		
32.5	bracket 254-256	2687812	cast iron ASTMA48CL 30 F2	2687812-B	bronze ASTMB584C87400		
32.6	bracket 254-256			2687812-SS	stainless steel 304		
32.7	bracket 254-256			2687812-DI	ductile iron 300 PSI GGG50		
32.8	bracket 254-256			2687812-CS	cast steel ASTMA216WCB		
32.9	bracket 284-326	2687813	cast iron ASTMA48CL 30 F2	2687813-B	bronze ASTMB584C87400		
32.10.	bracket 284-326			2687813-SS	stainless steel 304		
32.11	bracket 284-326			2687813-DI	ductile iron 300 PSI GGG50		
32.12	bracket 284-326			2687813-CS	cast steel ASTMA216WCB		
33	motor shaft key		carbon steel - 1045		stainless steel 18-8 open designation		
34.1	impeller washer no 1	WF1-SS	stainless steel 18-8 open designation				
34.2	impeller washer no 2	WF2-SS	stainless steel 18-8 open designation				
35.1	impeller bolt no 1	LBF1-SS	stainless steel 18-8 open designation				
35.2	impeller bolt no 2	LBF2-SS	stainless steel 18-8 open designation				
*36	casing gasket	G-12P	fiber gasket vellumoid				
37	motor bolts		carbon steel				



* recommended spares							
Series 880 model 6 X 6 X 12							
NO	PART NAME	PART NUMBER	STANDARD MATERIAL	PART NUMBER	OPTIONAL MATERIAL		
1	volute casing	2687432	cast iron ASTMA48CL 30	2687432-B	bronze ASTMB584C87400		
1.1	volute casing			2687432-SS	stainless steel 304		
1.2	volute casing			2687432-DI	ductile iron 300 PSI GGG50		
1.3	volute casing			2687432-CS	cast steel ASTMA216WCB		
*2.1	impeller 1 1/4	2685593-449	bronze ASTMB584C87400	2685593-491	cast iron ASTMA48CL30		
*2.2	impeller 1 1/4			2685593-SS	stainless steel 304		
3	motor shaft		carbon steel 4340 clear zinc plated				
*4	casing wearing	2691671-1	bronze ASTMB584C87400	2691671-1SS	stainless steel 18-8 open designation		
*5.1	shaft sleeve 354-326	SLJM1.500B	bronze ASTMB584C87400	SLJM1.500SS	stainless steel 18-8 open designation		
*6.1	mechanical seal 354-326	011-S150-21-per	viton/ceramic vs carbon w/stainless steel spring	011-S150-dirt	viton/silicone carbide w/stainless steel		
27	air vent valve plug						
28	impeller key		carbon steel ASTMA108G10800				
31	motor						
32.1	bracket 143-215	2687811	cast iron ASTMA48CL 30 F1	2687811-B	bronze ASTMB584C87400		
32.2	bracket 143-215			2687811-SS	stainless steel 304		
32.3	bracket 143-215			2687811-DI	ductile iron 300 PSI GGG50		
32.4	bracket 143-215			2687811-CS	cast steel ASTMA216WCB		
32.5	bracket 254-256	2687812	cast iron ASTMA48CL 30 F2	2687812-B	bronze ASTMB584C87400		
32.6	bracket 254-256			2687812-SS	stainless steel 304		
32.7	bracket 254-256			2687812-DI	ductile iron 300 PSI GGG50		
32.8	bracket 254-256			2687812-CS	cast steel ASTMA216WCB		
32.9	bracket 284-326	2687813	cast iron ASTMA48CL 30 F2	2687813-B	bronze ASTMB584C87400		
32.10.	bracket 284-326			2687813-SS	stainless steel 304		
32.11	bracket 284-326			2687813-DI	ductile iron 300 PSI GGG50		
32.12	bracket 284-326			2687813-CS	cast steel ASTMA216WCB		
33	motor shaft key		carbon steel - 1045				
34.1	impeller washer no 1	WF1-SS	stainless steel 18-8 open designation				
34.2	impeller washer no 2	WF2-SS	stainless steel 18-8 open designation				
35.1	impeller bolt no 1	LBF1-SS	stainless steel 18-8 open designation				
35.2	impeller bolt no 2	LBF2-SS	stainless steel 18-8 open designation				
*36	casing gasket	G-12P	fiber gasket vellumoid				
37	motor bolts		carbon steel				



* recommended spares					
Series	880	model	8 X 3 X 12		
NO	PART NAME	PART NUMBER	STANDARD MATERIAL	PART NUMBER	OPTIONAL MATERIAL
1	volute casing	2687435	cast iron ASTMA48CL 30	2687435-B	bronze ASTM584C87400
1.1	volute casing			2687435-SS	stainless steel 304
1.2	volute casing			2687435-DI	ductile iron 300 PSI GGG50
1.3	volute casing			2687435-CS	cast steel ASTMA216WCB
*2.1	impeller 1 1/4	2685596-449	bronze ASTM584C87400		cast iron ASTMA48CL30
*2.2	impeller 1 1/4				stainless steel 304
3	motor shaft		carbon steel 4340 clear zinc plated		
*4	casing wearing	2691670	bronze ASTM584C87400	2691670-SS	stainless steel 18-8 open designation
*5.1	shaft sleeve 354-326	SLJM1.500B	bronze ASTM584C87400	SLJM1.500SS	stainless steel 18-8 open designation
*6.1	mechanical seal 354-326	011-S150-21-per	viton/ceramic vs carbon w/stainless steel spring	011-S150-dirt	viton/silicone carbide w/stainless steel
27	air vent valve plug				
28	impeller key		carbon steel ASTMA108G10800		
31	motor.				
32.1	bracket 143-215	2687811	cast iron ASTMA48CL 30 F1	2687811-B	bronze ASTM584C87400
32.2	bracket 143-215			2687811-SS	stainless steel 304
32.3	bracket 143-215			2687811-DI	ductile iron 300 PSI GGG50
32.4	bracket 143-215			2687811-CS	cast steel ASTMA216WCB
32.5	bracket 254-256	2687812	cast iron ASTMA48CL 30 F2	2687812-B	bronze ASTM584C87400
32.6	bracket 254-256			2687812-SS	stainless steel 304
32.7	bracket 254-256			2687812-DI	ductile iron 300 PSI GGG50
32.8	bracket 254-256			2687812-CS	cast steel ASTMA216WCB
32.9	bracket 284-326	2687813	cast iron ASTMA48CL 30 F2	2687813-B	bronze ASTM584C87400
32.10	bracket 284-326			2687813-SS	stainless steel 304
32.11	bracket 284-326			2687813-DI	ductile iron 300 PSI GGG50
32.12	bracket 284-326			2687813-CS	cast steel ASTMA216WCB
33	motor shaft key		carbon steel - 1045		stainless steel 18-8 open designation
34.1	impeller washer no 1	WF1-SS	stainless steel 18-8 open designation		
34.2	impeller washer no 2	WF2-SS	stainless steel 18-8 open designation		
35.1	impeller bolt no 1	LBF1-SS	stainless steel 18-8 open designation		
35.2	impeller bolt no 2	LBF2-SS	stainless steel 18-8 open designation		
*36	casing gasket	G-12P	fiber gasket vellumoid		
37	motor bolts		carbon steel		

1A1 MODEL Cartridge Filter Housing



The 1A1 MODEL Cartridge Filter Housing is an all-metal, two-piece housing, featuring centerpost-type construction. The 1 A1 Model has a maximum operating temperature and pressure of 125 psig at 200°F. The 1A1 Model Cartridge Filter Housing has flow rates to up to 6 Gallons Per Minute (GPM).

APPLICABLE FILTER CARTRIDGES

Micro-Klean-III (Series U30)

Betapure-

DESIGN FEATURES

- All-metal, two-piece construction.
- Head and Sump Durable die-cast aluminum
- Mounting pads drilled to accept self-tapping screws provided with the optional mounting bracket.
- Centerpost-type design for easy cartridge changeout.

Options

- Mounting bracket; order separately.

STANDARD MODEL SPECIFICATIONS

Table 1 gives specifications for the 1A1 Model. Note that Maximum Operating Pressure is the rating for the housing only. Actual filter operating temperature depends on temperature capability of the filter cartridge used in the housing.

Operating Data	1A1 Model
Maximum Operating Pressure and Temperature	125 psi @ 200°F
Flow Rate (GPM)	See Table 2.
Materials of Construction	
Head and Sump	Die-Cast Aluminum
Centerpost	Stainless Steel
Head Gasket	Buna N & Cork
Cap-Nut Gasket	Fiber
Connection Sizes	3/8" NPTF
Cartridge Requirements	The model uses one filter cartridge. See "Cartridge Requirements" for more information.

TABLE 1 - SPECIFICATIONS

CARTRIDGE REQUIREMENTS

The 1A1 Model Cartridge Filter Housing uses one Micro-Klean III Cartridge or one Betapure Cartridge Filter.

FLOW RATES

Table 2 gives maximum flow rates in Gallons Per Minute (GPM) for the 1A1 Model Cartridge Filter Housings. Do not use Table 2 for filter sizing. Use the table as a guide only in establishing the housing flow rates. When you know the flow rate for a selected cartridge, then use the table to determine whether or not the housing is within the recommended flow rate. Remember to consider the amount of contaminant to be removed when selecting a filter.

Housing Model	Inlet / Outlet	FLOW (GPM)					
		Water	80 SSU	150 SSU	300 SSU	600 SSU	1000 SSU
1A1	3/8" NPTF	6	5	4.5	4	3.5	3

TABLE 2 - RECOMMENDED FLOW RATES

BENEFITS

- Long Service Life
- Quick and Easy Cartridge Change-out
- Reduced Down Time for Filter Change-out
- Reduced Labor Cost
- Uses Standard Filters
- Economical
- Easily Mounted to Wall or Support Structure



STANDARD MODEL DIMENSIONS

Table 3 gives dimensions in inches and shipping weight in pounds for the 1A1 Model Cartridge Filter Housing. These should be used for rough plumbing and approximate size definition. Note that figure 1 defines a length or width by a letter symbol in the top row. The square where the row and column meet is the selected dimension.

Model	A	B	C	D	Shipping Weight
1A1	6 3/16"	4 15/16"	3 1/2"	2 3/4"	3 lbs

TABLE 3. - 1A1 HOUSING DIMENSIONS

1A1 MODEL ORDERING GUIDE

Plant Code 01 Product Code 020

Model	Catalog Number	Mounting Bracket Kit*
1A1	44109-01	35581-05

* Order Separately

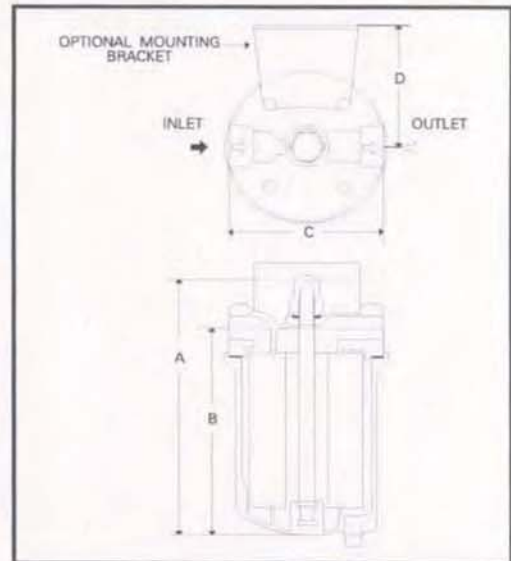

FIGURE 1. - 1A1 MODEL FILTER HOUSING

WARRANTY

Seller warrants its equipment against defects in workmanship and material for a period of 12 months from date of shipment from the factory under normal use and service and otherwise when such equipment is used in accordance with instructions furnished by Seller and for purposes disclosed in writing at the time of purchase, if any. Any unauthorized alteration or modification of the equipment by Buyer will void this warranty. Seller's liability under this warranty shall be limited to the replacement or repair, F.O.B., point of

manufacture, of any defective equipment or part which, having been returned to the factory, transportation charges prepaid, has been inspected and determined by Seller to be defective. THIS WARRANTY IS IN LIEU OF ANY OTHER WARRANTY, EITHER EXPRESSED OR IMPLIED, AS TO DESCRIPTION, QUALITY, MERCHANTABILITY, FITNESS FOR ANY PARTICULAR PURPOSE OR USE, OR ANY OTHER MATTER. Under no circumstances shall Seller be liable to Buyer or any third party for any loss of profits or



Terms and Conditions

LIMITED WARRANTY: We warrant to our immediate customer and to the ultimate consumer that products of our manufacture will be free of defects in material and workmanship under normal use and service for the following time periods, when installed and maintained in accordance with our instructions. Pumps Products: One (1) year from date of invoicing. As used herein, "the ultimate consumer" is defined as the purchaser who first uses the product after its initial installation or, in the case of product designed for non permanent installation, the first owner who used the product. It is the purchaser's or any sub-vendee's obligation to make known to the ultimate consumer the terms and conditions of this warranty. This warranty gives you specific legal rights, and there may also be other rights which vary from province to province. In the event the product is covered by the Consumer Product Warranty (1) the duration of any implied warranty associated with the product by virtue of said law is limited to the same duration as stated herein, (2) this warranty is a LIMITED WARRANTY, and (3) no claims of any nature whatsoever shall be made against us, until the ultimate consumer, his successor, or assigns, notifies us in writing of the defect, and delivers the product and/or defective part(s) freight prepaid to our factory or nearest authorized service station. THE SOLE AND EXCLUSIVE REMEDY FOR BREACH OF ANY AND ALL WARRANTIES WITH RESPECT TO ANY PRODUCT SHALL BE TO REPLACE OR REPAIR AT OUR ELECTION, F.O.B. POINT OF MANUFACTURE OR AUTHORIZED REPAIR STATION, SUCH PRODUCTS AND/OR PARTS REPAIR STATION, SUCH PRODUCTS AND/OR PARTS AS PROVEN DEFECTIVE. THERE SHALL BE NO FURTHER LIABILITY, WHETHER BASED ON WARRANTY, NEGLIGENCE OR OTHERWISE. Unless expressly stated otherwise guarantees in the nature of performance specifications furnished in addition to the foregoing material and workmanship warranties on a product manufactured by us, if any, are subject to laboratory tests corrected for field performance. Any additional guarantees, in the nature of performance specifications must be in writing and such writing must be signed by our authorized representative. Due to inaccuracies in field testing if a conflict arises between the results of field testing conducted by or for user, and laboratory test corrected for field performance, the latter shall control. Components or accessories supplied by us but manufactured by others are warranted only to the extent of and by the terms and conditions of the original manufacturer's warranty. RECOMMENDATIONS FOR SPECIAL APPLICATIONS OR THOSE RESULTING FROM SYSTEMS ANALYSES AND EVALUATIONS WE CONDUCT WILL BE BASED ON OUR BEST AVAILABLE EXPERIENCE AND PUBLISHED INDUSTRY INFORMATION. SUCH RECOMMENDATIONS DO NOT CONSTITUTE A WARRANTY OF SATISFACTORY PERFORMANCE AND NO SUCH WARRANTY IS GIVEN. This warranty shall not apply when damage is caused by (A) improper installation, (B) improper voltage (C) lightning (D) sand or other abrasive material (E) scale or corrosion build-up due to excessive chemical content. Any modification of the original equipment will also void the warranty. We will not be responsible for loss, damage or labour cost due to interruption of service caused by defective parts. Neither will we accept charges incurred by others without our prior written approval. This warranty is void if our inspection reveals the product was in a manner inconsistent with normal industry practice and/or our specific recommendations.

The purchaser is responsible for communication of all necessary information regarding the application and use of the product. UNDER NO CIRCUMSTANCES WILL BE RESPONSIBLE FOR ANY OTHER DIRECT OR CONSEQUENTIAL DAMAGES, INCLUDING BUT NOT LIMITED TO LOST PROFITS, LOST INCOME, LABOUR CHARGES, DELAYS IN PRODUCTION, IDLE PRODUCTION, WHICH DAMAGES ARE CAUSED BY ANY DEFECTS IN MATERIAL AND/OR WORKMANSHIP AND/OR DAMAGE OR DELAYS IN SHIPMENT. THIS WARRANTY IS EXPRESSLY IN LIEU OF ANY OTHER EXPRESS OR IMPLIED WARRANTY, INCLUDING ANY WARRANTY OF MERCHANTABILITY OR FITNESS FOR A PARTICULAR PURPOSE. No rights extended under this warranty shall be assigned to any other person, whether by operation of law or otherwise, without our prior written approval. If any litigation is commenced between the parties hereto for the enforcement of any rights hereunder, the successful party in subject litigation shall be entitled to receive from the unsuccessful party all costs incurred in connection therewith, including a reasonable amount of attorney's fees. YOUR ACCEPTANCE OF ANY GOODS SUPPLIED BY US, OR ON OUR BEHALF, SHALL, WITHOUT LIMITATION CONSTITUTE ACCEPTANCE OF ALL TERMS AND CONDITIONS STATED ABOVE.

PROJECT: _____
CONTRACTOR: _____
ENGINEER: _____
DATE: _____





Terms and Conditions

Our acceptance of your order is expressly conditioned on the general terms and conditions set forth below and all terms stated on the face of this form. The contract shall not include any deviating or additional terms unless expressly agreed to in writing and signed by an officer of our company.

PRICES: All prices are subject to change without notice and all shipments will be invoiced at the price in effect at the time of shipment, except when otherwise agreed to in writing by our authorized representative. Published prices are for products of our standard design and construction and any item not covered by the most recent published price list must be referred to us for special pricing. Prices do not include freight. Weights shown in price lists are approximate shipping weights. The amount of any applicable present or future tax or other government charge upon the production, sale, shipment or use of goods ordered or sold is not in the price and will be added to billing unless you provide us with an appropriate exemption certificate.

QUOTATION: Prices quoted by us are valid for 30 days from date of quotation unless we have otherwise specified in writing. Clerical errors on quotations are subject to our correction and such errors will not be binding.

CANCELLATION & REVISIONS: No purchase orders accepted and acknowledged by us may be cancelled or revised by you except with our prior written consent and upon payment of reasonable cancellation charges compensating us for all costs incurred in work done and material purchased. We reserve the right to determine what constitutes reasonable cancellation charges.

RETURN OF EQUIPMENT: No equipment shall be returned to us without first obtaining a written Returned Goods Authorization and shipping instruction from us. The returner must prepay the charges in full for transportation to our factory. Credit allowed for new, undamaged equipment of current standard design will be 80% of the invoiced price or current billing price, whichever is less. Equipment which has been used, however slight, will not be accepted. Authorization will not be given for return of equipment, (1) which would, in our opinion, result in an excess in the amount of stock we normally carry, (2) not invoiced within the last 3 months, or (3) which is non-standard and manufactured specifically to a buyer's specifications. For non-standard equipment not of our manufacture, the only credit allowed will be such credit as may be allowed by the manufacturer of such equipment. Equipment must be returned within 30 days of the issuance of the Returned Goods Authorization. No item with a net value of less than \$50.00 will be authorized for return. Unauthorized returns may be refused and/or returned freight collect.

CREDIT & PAYMENT: Payment is due as noted on our invoice. Overdue accounts are subject to a service charge. All orders are subject to approval of our credit department and we may require full or partial payment in advance. Pro rata payments shall become due as shipments are made. If the shipments are delayed by you for any cause, payments shall become due from date on which we are prepared to make shipment and storage shall be at your risk and expense. If manufacture is delayed by you for any

cause, a partial payment based upon the proportion of the order completed shall become due from the date on which we are notified of the delay.

SECURITY INTEREST: We shall have a lien on all goods sold as security for payment on the invoice price, and upon request you shall provide and execute a financing statement showing such lien.

DELIVERY: We will reasonable effort to meet your delivery requirement provided you provide us, on a timely basis, all approvals, technical data, instructions and credit approval requirements needed for release of the shipment. However, all delivery and/or shipment dates are estimates only unless we have expressly guaranteed delivery of such dates in writing at your specific request. In no event shall we have any liability if delivery is delayed by strikes, labour disturbances, material shortages, plant calamities or disaster, acts of God, government actions, civil disturbance, the failure of any pre-supposed condition of the contract, withholding shipments due to credit clearance, or other interferences beyond our reasonable control, and the date of delivery shall be extended for a period of time equal to the time lost because of any such reason.

SHIPPING: Unless you specify in writing and we acknowledge in writing, (A) goods will be boxed or crated as we may deem proper for protection against normal handling and for domestic shipment, (B) routing and manner of shipment will be at our discretion, and may be insured at your expense. An extra charge will be made for special handling. All shipments are F.O.B. point of manufacture. Delivery of goods to the initial carrier will constitute delivery to you and all goods will be shipped at your risk. A claim for loss or damage in transit must be entered with the carrier and prosecuted by you. Acceptance of material from a common carrier constitutes a waiver of any claims against us for delay, damage or loss.

GOVERNING LAW: It is understood and agreed that these Terms and Condition of Sale shall be interpreted under and pursuant to the laws of the Province of Quebec; you agree that any action at law which is related to any contract of sale brought against the company shall be filed in the appropriate court located in the Province of Quebec.

PROJECT: _____
CONTRACTOR: _____
ENGINEER: _____
DATE: _____



Nous sommes fier fournisseur des projets suivants, soient terminés ou en cours de projets :



Peruvian Park Elementary
1545 E 8425 S, Sandy,
UT, US



Greenbush Elementary School
127 Greenbush Rd, West
Warwick, RI, US



Canadian National
935 Rue De la Gauchetière
Ouest, Montréal, QC, CA



Montreal's Archives
535 Rue Viger Est,
Montréal, QC, CA

Vente & Service:

Québec, Canada
Tél. : (450) 621-2995
Fax : (450) 621-4995

Lake Worth
Florida, USA
33467-5749

Toronto, Canada
Tel. : +1 (647) 544-2995

www.flofab.com

SERVICE 24/7 : parts@flofab.com

