



# ***XRI series***

***Detachable type in line pump***

***Installation and operation manual***

**Flo Fab Inc.**

# *Content*

<b>0 General</b> .....	<b>1</b>
<b>0.0 Safety Manual</b> .....	<b>1</b>
<b>0.1 Marking of manual</b> .....	<b>1</b>
<b>0.2 Personal qualification and training</b> .....	<b>2</b>
<b>0.3 Non-compliance with safety manual</b> .....	<b>2</b>
<b>0.4 Safety awareness</b> .....	<b>2</b>
<b>0.5 Safety manual s for operators and users</b> .....	<b>2</b>
<b>0.6 Safety manual s for maintenance, inspection and installation work</b> .....	<b>3</b>
<b>0.7 Unauthorized modification and manufacture of spare parts</b> .....	<b>3</b>
<b>1.0 Transportation and lifting manuals</b> .....	<b>3</b>
<b>1.1 Transportation</b> .....	<b>3</b>
<b>1.2 Lifting instructions</b> .....	<b>3</b>
<b>2.0 Product specification description</b> .....	<b>1</b>
<b>2.1 Technical specification</b> .....	<b>1</b>
<b>2.2 Model explanation</b> .....	<b>1</b>
<b>3.0 Site installation</b> .....	<b>1</b>
<b>3.1 Safety regulations</b> .....	<b>1</b>
<b>3.2 Checking before installation</b> .....	<b>1</b>
<b>3.3 For pump unit installation</b> .....	<b>2</b>
<b>3.4 Connection of pipe</b> .....	<b>2</b>
<b>3.5 Coupling guard</b> .....	<b>2</b>
<b>4.0 Commissioning, Start-up shutdown</b> .....	<b>2</b>
<b>4.1 Testing</b> .....	<b>2</b>
<b>4.2 Checking the Rotation Direction</b> .....	<b>3</b>
<b>4.3 Startup</b> .....	<b>3</b>
<b>4.4 Pumps working condition range</b> .....	<b>3</b>
<b>4.5 Shutdown</b> .....	<b>3</b>
<b>4.6 Storage maintenance</b> .....	<b>4</b>
<b>4.7 Measures for continued shutdown</b> .....	<b>4</b>
<b>5.0 Maintenance</b> .....	<b>4</b>
<b>5.1 General manual</b> .....	<b>4</b>
<b>5.2 Maintenance acceptance</b> .....	<b>4</b>
<b>5.3 Disassembly</b> .....	<b>5</b>
<b>5.4 Basic manual s and Suggestions</b> .....	<b>5</b>
<b>6.0 Causes of faults and elimination methods</b> .....	<b>6</b>
<b>7.0 Routine and interval maintenance</b> .....	<b>1</b>

## **0 General**

*The pump combines the latest and most advanced science and technology to maximize the quality control of each step in the manufacturing process.*

*This operating manual is designed to provide necessary information for operating the pump and specific uses.*

*This manual provides very important advices for running the pump reliably, properly and efficiently, people must obey the rules strictly, to ensure that the product reliability and prolong the service life of pump, and to avoid accidents and dangerous.*

*This manual do not consider the local regulations; Operators must obey the laws and regulations strictly, including requiring operators to install them.*

*The pump shall not exceed the specified limit in operating technical documents, including the conveying medium, flow rate, speed, density, pressure, temperature and the grade of the motor. To ensure that the operation is in accordance with this manual or contract.*

*The nameplate is marked with the modelsize, mainly running the data and sequence number. If you have any problem, please let us know the data and order number, especially when you need to order spare parts.*

*If you need other information or beyond the scope of this manual to avoid damage, please contact our nearest customer service center.*

### **0.0 Safety Manual**

*The operator is responsible of ensuring that all maintenance, inspection and installation work be performed by authorized, qualified specialist personnel who are thoroughly familiar with the manual.*

*It is not only in accordance with the provisions of this chapter for "security", but also in accordance with the safety manual s in other specific sections.*

### **0.1 Marking of manual**

*The safety manual s contained in this manual whose non-observance might cause hazards to persons, this is general hazard sign.*



*According to DIN 4844-W9, this is an electrical dander warning sign.*



*According to DIN 4844-W9, word: caution.*

*The word is used to introduce safety manual s whose nonobservance may lead to damage to the machine and its functions.*

*Manual s attached to the machine, for example:*

*The arrow indicates the direction of rotation*

*Sign of overcurrent parts*

*These marking of signs should be strictly observed and legible at all times.*

## **0.2 Personal qualification and training**

*All personnel involved in the operation, maintenance, inspection and installation of the machine must be fully qualified to carry out the work involved. Personnel responsibilities, competence and supervision must be clearly defined by the operator. If the personnel in question are not already in possession of the requisite know-how, appropriate training and manual must be provided. If required, the operator may commission the manufacturersupplier to take care of such training. In addition, the operator is responsible for ensuring that the contents of the operating manual s are fully understood by the responsible personnel.*

## **0.3 Non-compliance with safety manual**

*Non-compliance with safety manual s can jeopardize the safety of personnel, the environment and the machine itself. Non-compliance with these safety manual s will also lead to forfeiture of any and all rights to claims for damages.*

*In particular, non-compliance can, for example, result in:*

*Failure of important machineunit functions*

*Failure of prescribed maintenance and servicing practices*

*Hazard to persons by electrical, mechanical and chemical effects*

*Hazard to the environment due to leakage of hazardous substances*

## **0.4 Safety awareness**

*It is necessary to comply fully with the safety manual s of this manual and the relevant national health and safety regulations as well as its own internal rules on operating machinery and safety.*

## **0.5 Safety manual s for operators and users**

*Any risk from pump cold and hot components may endanger worker's safety, shall be equipped with protect cover. Protection device must not be removed (such as coupling guard) while the machine is operating.*

*Leakage of dangerous medium (such as inflammable, explosive, toxic, high temperature) must be controlled (such as shaft seal), to avoid harms to workers and the environment, and to obey relevant laws and regulations.*

*There is a need to eliminate the risk of electricity, and to reference the provisions of localnational security laws and regulations or local energy supplier regulations.*

## **0.6 Safety manual s for maintenance, inspection and installation work**

*The operator is responsible for ensuring that all maintenance, inspection and installation work be performed by authorized, qualified specialist personnel who are thoroughly familiar with the manual. Work on the machine should be carried out only during shutdown. The shutdown procedure described in the manual for taking the machine out of service must be adhered to without fail. Pumps or pump units handling media injurious to health must be decontaminated. Immediately following completion of the work all safety-relevant and protective devices must be reinstalled and re-activated. Please observe all manual s set out in the chapter on Commissioning" before retiming the machine to service.*

## **0.7 Unauthorized modification and manufacture of spare parts**

*Modifications or alterations of the machine are only permitted after consultation with the manufacturer. Original spare parts and accessorized authorized by the manufacturer ensure safety. The use of other parts can invalidate any liability of the manufacturer for consequential damage. The warranty relating to the operating reliability and safety of the pump supplied is only valid if the machine is used in accordance with its designated use and if all operating manual s described in chapter 1 have been followed.*

## **1.0 Transportation and lifting manuals**

*Proper preparation, loading and unloading measures should be taken in the process of transportation. Please follow the following safe operation manual s.*

### **1.1 Transportation**

*In any case, whatever the means of transportation, for example, roads, railways, ships, It is recommended that the equipment be transported vertically and ensure that the equipment be placed horizontal and stable.*



*The unit should be fixed on the appropriate trays or sled, and all loose parts must be fixed.*

### **1.2 Lifting instructions**



*The lugs on the motor is only used to lifting the motor, not for the whole pump unit. For heavy duty pump installation, the pump can be connect to pipe first then lifting the motor and install on the pump.*

## **2.0 Product specification description**

### **2.1 Technical specification**

*XRI series pump is single stage, single suction, radically split vertical inline pump. The centerline of suction is parallel to the centerline discharge, in the same side. Or a U shape installed at a certain angle.*

*XRI series pump is single stage, single suction, radically split vertical inline pump. The centerline of suction is parallel to the centerline discharge, in the same side. Or a U shape installed at a certain angle.*

*This series pump rotation is clockwise viewed from motor end.*

*Connection flanges can be selected according to customer's requested, and manufactured according to relevant standard*

### **2.2 Model explanation**

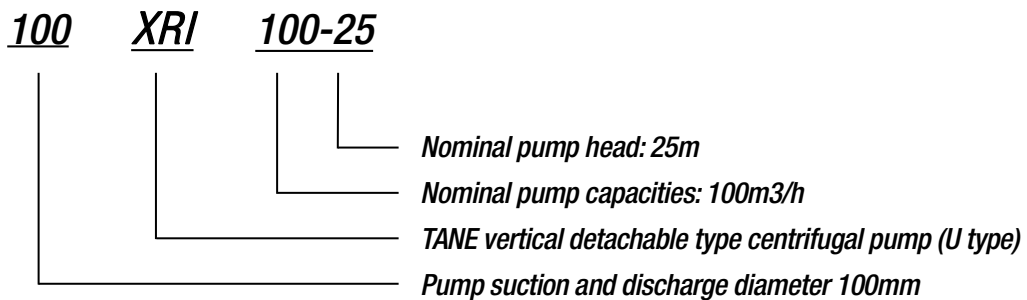

## **3.0 Site installation**

### **3.1 Safety regulations**



*Electrical equipment must comply with anti-explosion regulations in hazardous area. If the equipment is installed in a dangerous area, it must comply with the provisions of the local explosion regulations.*

*The test certificate must be placed close to the machine for inquiry.*

### **3.2 Checking before installation**

*To check the fixed parts of the unit before installing the unit, and to check whether the pump channel blocked with foreign material.*

*The foundation of cement shall have adequate strength and horizontal surface.*

### **3.3 For pump unit installation**

*The pump unit will be hoisted steadily on the cement foundation, and adjust position in the horizontal and vertical direction, the anchor bolts must be tightened when installed, in order to avoid the effect of vibration on pump performance when starting.*

### **3.4 Connection of pipe**



*Note: The pump shall not bear any weight from pipes at installation, in order to prevent pumps from deformation. The pipe connection on the pump does not pass any stress or tension.*

*The diameter of the pipe is at least as much as the diameter of the pump suction and discharge.*

*The stress of the auxiliary equipment cannot exceed the limitation. Too much stress in the pipeline cause the pump to leak and the pump medium will leak into the air, it is dangerous if the medium is high temperature or flammable explosive.*

*Dismantling the cover plate from the pump suction and discharge flange before installing the pipeline.*

### **3.5 Coupling guard**

*According to the provision of prevent accidents, the coupling guard must be installed when the pump is running, if the customer requires with no need for coupling guard, the user must provide it by themselves.*

## **4.0 Commissioning, Start-up shutdown**

*It is extremely important to operate according to the following requirements. Causing losses in violation of the provisions of manual is not within the scope of quality assurance.*

### **4.1 Testing**

*Before starting the pump, you shall make the following preparations:*

*Whether the pump firmly bolted to the baseplate or foundation?*

*Whether or not the piping properly installed?*

*Whether the motor installed according to the operating manual?*

*Is it easy to rotate the unit from the end of the coupling? (at least one lap )*

*Whether the coupling guard installed?*

*Is there any information about the source of the risk to the shaft and measures to prevent accidents from occurring?*

*Are there any overload protection facilities? (Security valve)*

*Whether other devices ready and installed according to their operation requirements?*

## 4.2 Checking the Rotation Direction

*Note: To ensure the unit running smoothly, it is extremely important to confirm the rotor rotation direction. If the rotation direction is not correct, the pump cannot reach the design point, resulting in vibration and overheating, and the unit and shaft seal will be damaged.*

*The motor rotation matches indication of arrow on the pump, the rotation can be checked by turning off after the machine is turned on.*



*To make sure there is no clutter in the pump before checking the direction of rotation. It is forbidden to put hands or other objects in the pump.*

## 4.3 Startup

*Dry running will accelerate abrasion, which should be avoid.*

*Close the discharge valve, if there is no reverse valve.*

*If the suction is equipped with throttle valve, open it fully. All auxiliary equipment, such as cooling, heating, lubrication, watering or sealing liquid, must be fully opened or turned on, and checking the flow.*

*Turn on the motor power switch.*

*When the pump starts transfer liquids, it can be seen through the pressure test instrument and slowly open the discharge valve until it fully open. Close the discharge valve only when you startup or shutdown, otherwise the temperature will increase and cause damage to the pump.*

## 4.4 Pumps working condition range

*According to the features of the performance curve, the flow rate will be adjusted automatically according to the heads. The working condition range of the pump is also limited to the range of performance curves.*

*Pump is not allowed to run between shut-off and minimum flow rate.*

*If the pump continue to run in this area, which will cause mechanical load will increase, and the other components will be hard to bear, it will be ok to run at this critical range temporarily when the pump starting.*

## 4.5 Shutdown

*Close the discharge valve. If the discharge has a check valve, the pipe has back pressure, and the discharge valve cannot be closed.*



*Suction valve cannot be closed when shutdown, turning off the electrical power, to ensure the unit stop work steadily.*

*According to the situation of system, the pump should have a proper rest period after operation, closing heat power, letting the medium cool enough and to avoid heating pump.*

*The suction valve and the auxiliary equipment must be closed during the long period of shutdown time. The pump must be drained to prevent freezing during the frosts time and long period of shutdown time.*



#### **4.6 Storage maintenance**

*Each pump is assembled carefully before delivery . If pump commissioned after a certain time after delivery, we suggested following measures for storage .*

*pump set should not stored more than 1 year after delivery*

*pump set should be stored indoors, in the dry position*

#### **4.7 Measures for continued shutdown**

*In order to ensure the pump startup immediately at any time, during the period of shutdown time, every month or every three months should be started regularly(about 5 minutes), ensuring that there will be enough liquid so that pump will actually be able to be turned on before operation.*

*Before stored, take the pump out of the pipe and then check it out, as defined in 5.1 and 5.4.*

*The suction and discharge should also be treated specially, it is better to seal the suction and discharge. (For example: plastic cover or equal).*

### **5.0 Maintenance**

#### **5.1 General manual**

*The operator is responsible for ensuring that all maintenance, inspection and installation work be performed by authorized, qualified specialist personnel who are thoroughly familiar with the manual.The regular maintenance can avoid expensive repairing fees, troubles and improve the running reliability by using minimal maintenance fees and work.*



*Any maintenance of the pump must be carried out in the off condition, ensuring that the pump is not accidentally switched on automatically (hazard)*

*It is necessary to purify the harmful liquid when pump running and during the drainage process, it is necessary to obey the relevant laws and regulations to check whether it will harm the health and pollute environment*

#### **5.2 Maintenance acceptance**

##### **5.2.1 Operational management**



*The pump shall run quietly without vibration, and shall not dry running at any time. It is not allowed to close the valve running for long periods of time, in order to avoid heating the pumping liquid.*

*If the temperature of the room is below 30 degrees, the temperature of shaft bearing is not permitted exceeding 90 degrees, if the temperature of the room is warmer, the temperature of shaft bearing shall be controlled under 100 degrees.*

*The valve on the suction line cannot be closed when pump running, Spare parts should be started and*

*stopped at least one time per week, in order to start immediately at any time.  
Pay attention to ensure the function of auxiliary equipment.  
If the parts on the coupling show signs of deterioration, you should replace the parts timely.*

#### **5.2.2 Maintenance of pump shaft seal**

*The maintenance work of seal parts will be according to the manual of the seal.*

#### **5.2.3**

*The shaft bearing has been injected with lubricating grease when the pump is out of the factory. It is just needed to add lubricating grease regularly during operation.*

### **5.3 Disassembly**

*Before dismantling, secure the pump so as to make sure it cannot be switched on accidentally. Valves on the suction and discharge line shall be closed, the pump cooled down to the ambient temperature, the pump housing shall be drained, and all pressure released.*

*Dismantling the coupling does not need special tools, please refer to the structure drawing for installation of different options.*

*Dismantling the whole rotor without moving the suction and discharge pipeline.*

### **5.4 Basic manuals and Suggestions**

*The repair and maintenance of pumps can only be operated by trained professional staff, with the original accessories provided by the factory.*

*Pay attention to safety regulations, all work on the motor must be carried out according to the specifications and requirements of the respective motor suppliers.*

*Disassembly and assembly must be based on the manuals of the relevant general drawings, the general assembly drawing and other documents in the attachment, the disassembly sequence is also based on the general assembly drawing, you can contact our after-service department at any time for avoiding damage to the unit.*

## 6.0 Causes of faults and elimination methods

<i>faults</i>	<i>causes</i>	<i>remedies</i>
1. No Liquid Flow out	<ul style="list-style-type: none"> <li>a. Suction and discharge valve is not open, pipeline block and impeller passage block.</li> <li>b. The motor is running in the wrong direction, motor running in a low speed, missing phase.</li> <li>c. Suction leak.</li> <li>d. The pump is not filled with liquid, there is air in the pump cavity.</li> <li>e. Insufficient suction liquid supply, higher suction, and the foot valve leak.</li> <li>f. Too big resistance in the pipeline, unsuitable selection of pump type</li> </ul>	<ul style="list-style-type: none"> <li>a. Check and remove the obstruction</li> <li>b. Adjust the motor running direction and fasten motor wiring.</li> <li>c. Screwing up seal surface and eliminating air</li> <li>d. Open the pump cover or vent valve and exhaust air</li> <li>e. Stop the machine to check and adjust suction.</li> <li>f. Reduce the pipe corners and reselect the pump</li> </ul>
2. Inadequate capacities	<ul style="list-style-type: none"> <li>a. Pressing 1 to check the reason</li> <li>b. Pipeline, pump flow channel, impeller section block, dirt deposition, insufficient opening.</li> <li>c. Low voltage</li> <li>d. Impeller abrasion</li> </ul>	<ul style="list-style-type: none"> <li>a. Pressing 1 to eliminate</li> <li>b. Remove the obstructions and readjust the valve opening</li> <li>c. Steady voltage</li> <li>d. Replace impeller</li> </ul>
3. Excessive Power consumption	<ul style="list-style-type: none"> <li>a. Exceeding the rated flow.</li> <li>b. High Suction head</li> <li>c. Bearing abrasion</li> </ul>	<ul style="list-style-type: none"> <li>a. Adjust flow and turn down the discharge valve.</li> <li>b. Reduce the suction head</li> <li>c. Replace shaft bearing</li> </ul>
4. Noise vibration	<ul style="list-style-type: none"> <li>a. Instability line support.</li> <li>b. Liquids mix with gases</li> <li>c. Air erosion</li> <li>d. Shaft bearing failure</li> <li>e. The motor overloads and heating</li> </ul>	<ul style="list-style-type: none"> <li>a. Firm pipe</li> <li>b. Increasing suction pressure and exhausting</li> <li>c. Reducing Vacuum</li> <li>d. Replacing shaft bearing</li> <li>e. Pressing 5 to adjust</li> </ul>
5. Motor heating	<ul style="list-style-type: none"> <li>a. Excessive capacity, overload operation</li> <li>b. Friction</li> <li>c. Shaft bearing damage and motor failure.</li> <li>d. Under voltage</li> </ul>	<ul style="list-style-type: none"> <li>a. Turn down the discharge valve.</li> <li>b. Check and eliminate</li> <li>c. Replace Bearing</li> <li>d. constant voltage</li> </ul>
6.	<ul style="list-style-type: none"> <li>a. Wear of mechanical seal</li> <li>b. Sand holes and cracks on the pump body</li> <li>c. Seal face is not flat</li> <li>d. Bolt loose</li> </ul>	<ul style="list-style-type: none"> <li>a. Replace</li> <li>b. repair or replacement</li> <li>c. Repair</li> <li>d. Fasten</li> </ul>

## **7.0 Routine and interval maintenance**

<i>Period</i>	<i>Number of maintenance personnel</i>	<i>Time (hour)</i>	<i>Content</i>
<i>every day</i>	<i>1</i>	<i>1/10</i>	<i>Check the mechanical seal leakage</i>
<i>every week</i>	<i>1</i>	<i>1/4</i>	<i>Check the running situation of pump (capacities, heads, motor temperatures, noise and vibration)</i>
<i>every month</i>	<i>1</i>	<i>1/4</i>	<i>Starting the pump and testing the pump for 5 minutes as possible.</i>
<i>Running two million per hour.</i>	<i>2</i>	<i>3</i>	<i>Replace bearing, and reference manual of the bearing.</i>
<i>every four years or the head of pump decreases</i>	<i>2</i>	<i>6</i>	<i>According to the manual s to overhaul the pump, replace the corresponding parts, such as: impeller seal ring, impeller, shaft.</i>

# XRI structure drawing

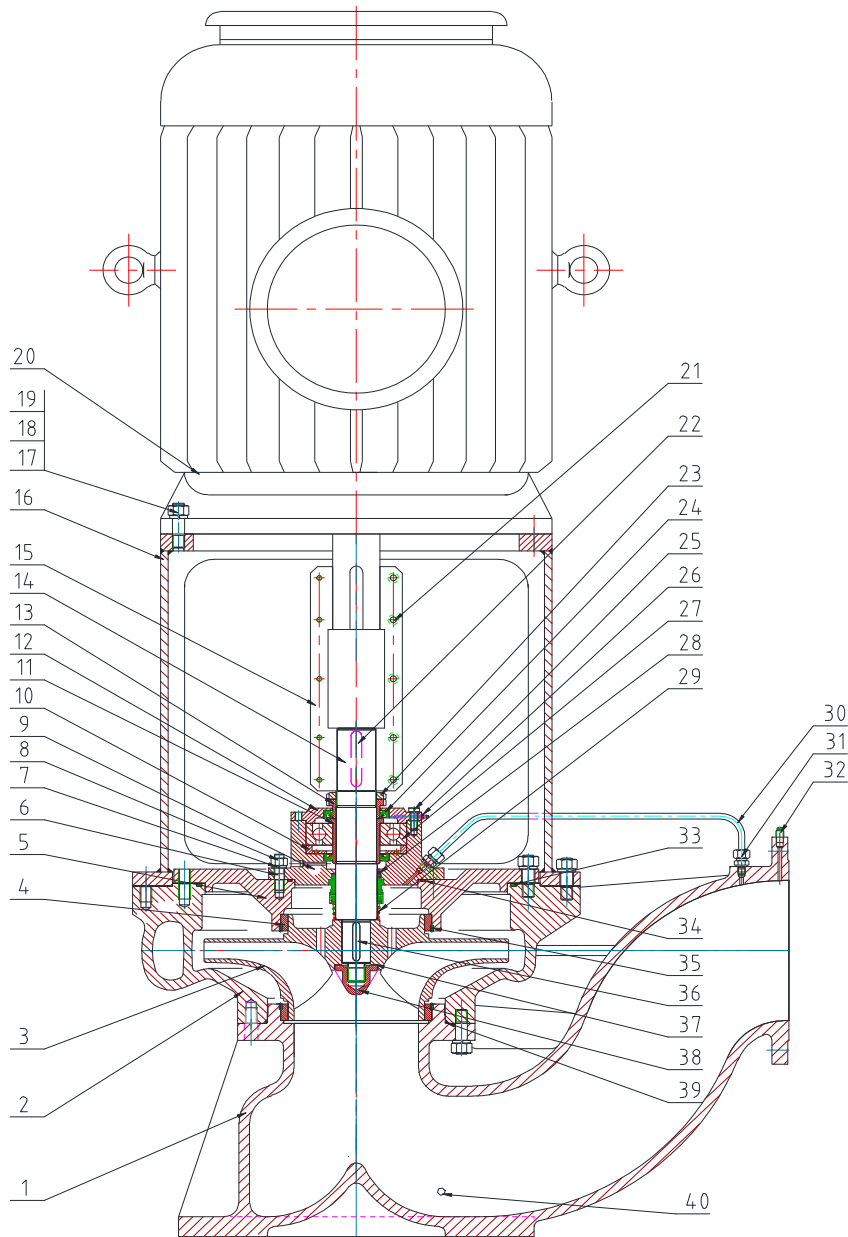

- |                      |                     |                                  |                       |
|----------------------|---------------------|----------------------------------|-----------------------|
| 1. Suction           | 11. Bearing sleeve  | 21. Screw                        | 31. Cartridge connect |
| 2. Casing            | 12. Bearing cover   | 22. Key                          | 32. Plug              |
| 3. Impeller          | 13. Bearing nuts    | 23. Round nut                    | 33. O-ring            |
| 4. Wear ring         | 14. Shaft           | 24. Lip-type seal ring           | 34. O-ring            |
| 5. Casing cover      | 15. Coupling        | 25. Hex nuts                     | 35. Screw             |
| 6. Studs             | 16. Motor baseplate | 26. Grease nipple                | 36. Key               |
| 7. Spring washer     | 17. Studs           | 27. Angular contact ball bearing | 37. Gasket.           |
| 8. Hex nuts          | 18. Spring washer   | 28. Round pin                    | 38. Impeller nuts.    |
| 9. Bearing baseplate | 19. Hex nut         | 29. Mechanical seal              | 39. O-ring            |
| 10. Bearing ring     | 20. Motor           | 30. Seamless tube                | 40. Plug              |