

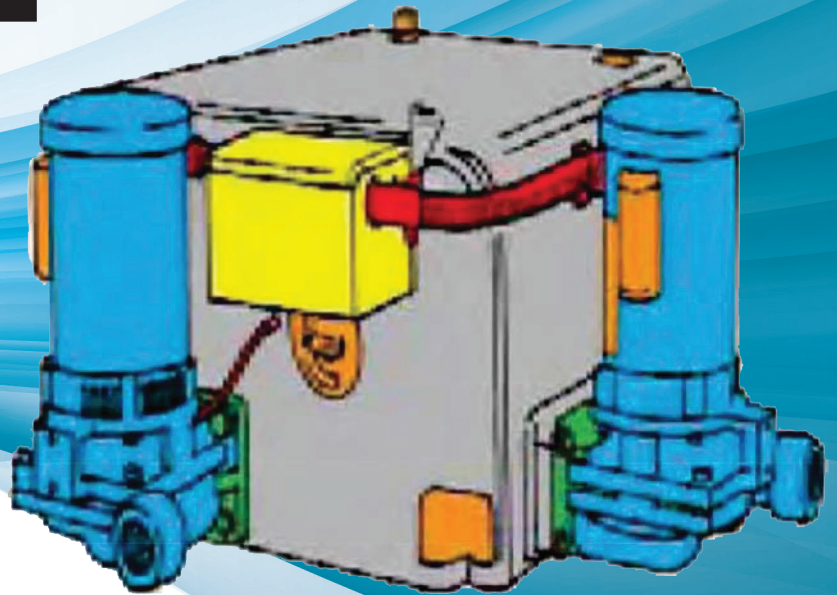

# Condensate Vertical Centrifugal Pumps

## Series CVC/GV6

Operation, Maintenance  
& Installation Manual



# **CAUTION!!**

**DO NOT RUN PUMP DRY, SEAL DAMAGE MAY OCCUR. INSPECT PUMP SEAL REGULARLY FOR LEAKS, REPLACE AS REQUIRED.**

**FOR LUBRICATION REQUIREMENTS, CONSULT SERVICE INSTRUCTIONS. FAILURE TO FOLLOW INSTRUCTIONS COULD RESULT IN INJURY OR PROPERTY DAMAGE. COUPLER ALIGNMENT IS REQUIRED! LEVEL AND GROUT PUMP BEFORE USE!**

**CHECK ALIGNMENT BEFORE GROUTING, AFTER SYSTEM 18 FILLED, AFTER SERVICING PUMP, AND AS REQUIRED.**

**CONSULT THE SERVICE INSTRUCTIONS FOR DETAILS. FAILURE TO FOLLOW THESE**

**INSTRUCTIONS COULD RESULT IN INJURY OR PROPERTY DAMAGE. FAILURE TO FOLLOW THIS INSTRUCTION MAY VOID THE WARRANTY OF THE UNIT.**



## VERTICAL IN LINE PUMPS

FLO FAB In Line pumps are designed to be mounted vertically in the pipe line with the motor above the pump. Center line suction and discharge keep weight evenly balanced and directly down upon the piping. No flexible connections to take up pipe misalignment are necessary since pump is not permanently connected to anything but the piping and is free to move with the expansion and contraction of the piping system. Support of the piping at the pump may be made by two pipe hangers, floor saddles or floor flanges, placed on line close to the pump.

Selection of the actual type of support is determined after consideration of the structural characteristics at the location of the pump, size and weight of both the piping and the pump, expansion and contraction of the piping, etc. In other words, the same criteria and formula for selecting piping supports are used with the additional consideration that the weight of the pump is concentrated at one point in the piping. Otherwise, piping recommendations are the same as for other types of pumps. For example, gate valves should be installed at both the pump suction and discharge to permit servicing of the pump without draining the entire system. If vertical in-line pumps are mounted in a straight horizontal run of piping, then the weight of the piping and pump system is generally supported by pipe supports, or spring hangers, and experience has shown that no additional pump support, vibration or noise isolation devices are required.

## CAUTION

- A. INSTALL VERTICAL IN INLINE PUMPS WITH MOTOR IN VERTICAL POSITION.
- B. MAKE CERTAIN THE SPACE ABOVE THE PUMP IS SUFFICIENT TO GIVE CLEARANCE FOR LIFTING THE PUMP ASSEMBLY FROM THE CASING. ALSO THE SPACE AROUND THE PUMP SHOULD BE LARGE ENOUGH FOR GENERAL ACCESSIBILITY AND VENTILATION.
- C. SUPPORT PUMP ONLY BY PIPING.
- D. MANUALLY VENT ALL AIR FROM CASING.
- E. MAKE SURE SUCTION VALVE IS WIDE OPEN BEFORE STARTING MOTOR
- F. CHECK MOTOR ROTATION (CLOCKWISE LOOKING DOWN FROM TOP OF MOTOR).

### FLOOR MOUNTED TYPE VERTICAL IN LINE PUMPS

Larger FLO FAB Vertical In Line pumps and Split Coupled pumps have supporting Floor plate under the casing. These pumps are to be floor mounted but other wise piped-up the same way os shown. Although Vertical In line pumps ore vibration free, it is recommended for floor mounted pumping units to provide isolation between pedestal block and foundation structvre and flexible members in pipes adjacent to pump. Typically, the natural rubber pad would hove a hardness in the range of 50 durometres, a thickness of 0.375 inches and up, depending on the loading and site conditions, and be designed for a maximum detection of 8 mm. This arrangement has been used, successfully, for many years on all types of flooring systems. The recommended arrangement diminishes noise transmission and provides adequate vibration isolation in the horizontal and vertical planes.

### When Installing MFV Valve

If you are using the MFV valves as a balancing valve, you must hove these installed 10 times the pipe size diameter to obtain any type of accuracy. IF these are only to be used as a throttling, check, and shut off valve, then 5 times the pipe diameter after the pump discharge is accep- table. If the system balancing at less than 50% stem rise and this is the primary balance valve, ASHREA Standard 90.1 and Flo Fob recommend trimming the impeller to the necessary system design flow. This will reduce electrical energy consumption and comply with the Notional Energy Building Code Standard. To avoid noise problems ond possible damage to the valve I do not exceed 25 feet of pressure drop across the MFV valve.

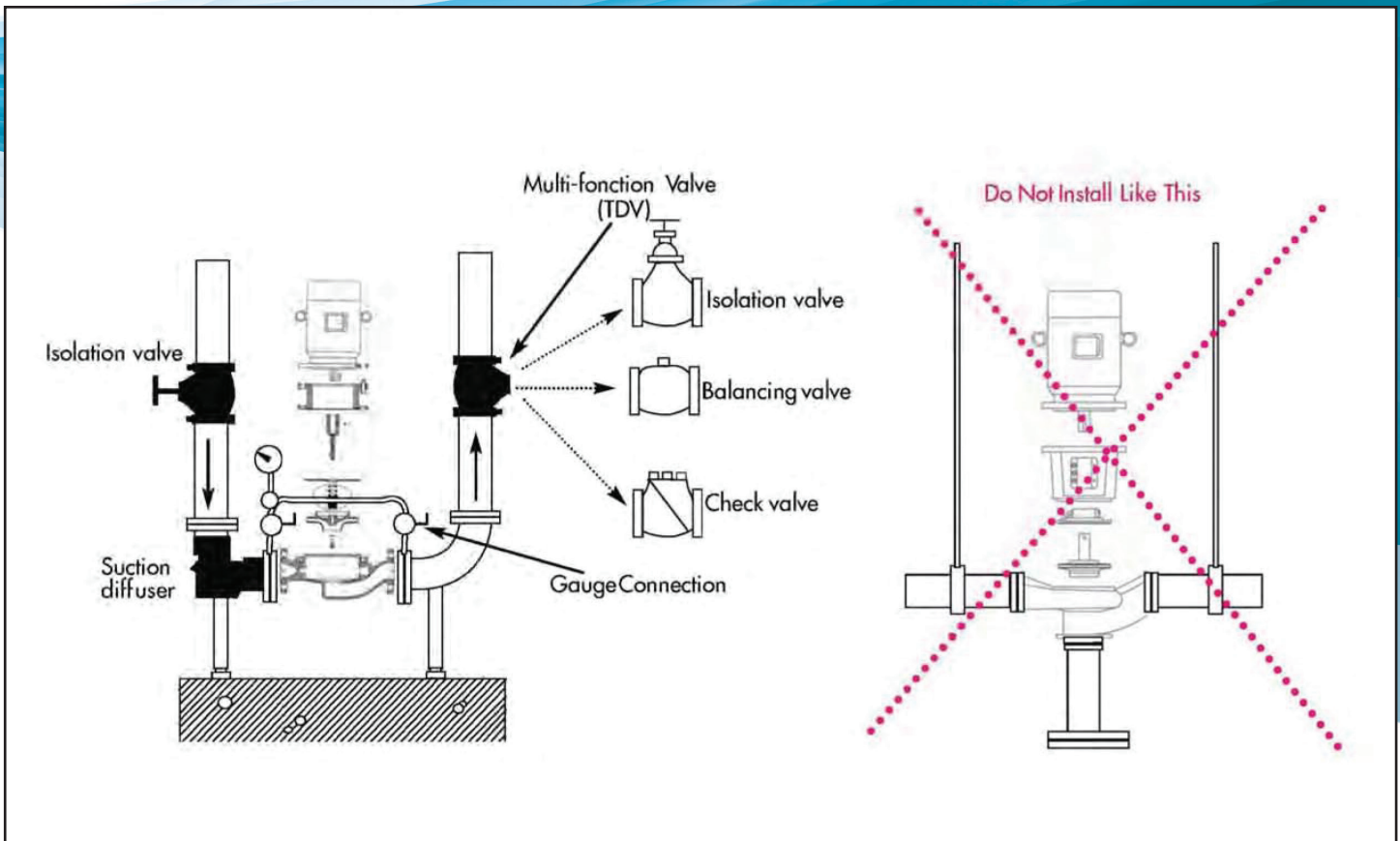





# OPERATION

## STARTING OF ELECTRIC MOTOR DRIVEN PUMPS

1. Before connecting motor and starter to the line:
  - 1.1. Check wiring information available inside the conduit box.
  - 1.2. Check voltage and frequency of power supply with what s shown on motor nameplate.
  - 1.3. Check current rating of overload relays and fuses against nameplate full load current value.
2. Check lubrication and pocking (see MAINTENANCE}.
3. Check if rotor is free to turn. It must be possible to revolve the rotor by hand. If the rotor drags even slightly, do not operate until the cause of trouble is located and corrected.
4. For unit with fluid drive, refer to the maintenance instructions of Auid drives.
5. If unit is for high temperature application, refer to operating instructions For high temperature pumps.
6. Prime the pump. A pump is primed when cosing and suction line are filled with liquid and when all the air contained in the pump has been allowed to escape. If pump is to operate under suction lift without foot valve, priming is done by pumping air out by means of an ejector, on exhauster or a vacuum pump.
7. Check direction of driver rotation. Proper direction is indicated by arrow on pump ca sing.
8. Check electric motor current as soon as motor is started to verify whether or not the mechanical load applied corresponds to the motor rating. The continuous full load current value should be within the electric motor nameplate rating with service factor taken into account.

## CAUTION

- A. MAKE SURE THE GATE VALVE ON PUMP SUCTION IS FULLY OPEN AS THROTILING ON SUCTION SIDE IS HARMFUL TO THE PUMP.
- B. MAKE SURE PUMP WILL NOT RUN DRY. MOST CENTRIFUGAL PUMPS HAVE CLOSE CLEARANCES AND CANNOT RUN DRY WITHOUT SERIOUS DAMAGE RESULTING.



# MAINTENANCE

A systematic inspection made at regular intervals, giving special attention to the following, will ensure years of trouble-free operation.

## GENERAL CARE

- 1 . Keep unit clean.
2. Avoid excessive belt tension.
3. Provide the motor with adequate overload protection.
4. Keep flying chips or other loose particles away from the ventilating openings of the motor.
5. Avoid operating the unit in overheated surroundings.
6. Guard three phase motor against single phasing which is frequently accompanied by an unusual humming sound, a drop in speed, and by excessive heating which, if continued, may burn out the motor windings.
7. Use thermometers when checking temperatures.
8. If pump is standing idle in freezing weather, pump casing and piping should be drained.

## BEARINGS

1. LIFE LUBRICATED BEARINGS are heavy duty permanently lubricated, sealed type and require no maintenance
2. GREASE LUBRICATED BEARINGS require very little attention. More trouble can be caused by overcharging than by undercharging with grease. Approximately every month, depending on service, inject a small quantity of grease (Esso Andok No. 280 or equal} into bearing container after removing the grease outlet plug so that old grease is flushed out and bearing is not over-filled.



### MECHANICAL SHAFT SEAL LIMITATIONS

Standard FLO FAS pumps are equipped with mechanical seals. Standard mechanical seals have Ni-resist seat, carbon washer and Viton below. Maximum recommended operating temperatures and pressures are shown below.

MOTOR HP & SPEED	SUCTION PRESSURE (PSIG)	MAXIMUM TEMPERATURE (°F)
Up to 10HP 1750 RPM	60	250
	85	225
	125	160
15 - 50HP 1750 RPM	50	250
	60	225
	100	160
Up to 15HP 3500 RPM	20	180
	125	120
20 - 60HP 3500 RPM	15	180
	115	120

## CAUTION

- A. A MECHANICAL SEAL IS A PRECISION PRODUCT. HANDLE IT WITH CARE. SPECIAL CARE MUST BE TAKEN WITH THE SEALING WASHER AND SEAT. DO NOT LET THEM DROP AND TAKE PARTICULAR CARE NOT TO SCRATCH THE LAPPED FACES.
- B. NEVER RUN SEALS DRY.
- C. FOLLOW SEAL MANUFACTURER'S INSTRUCTIONS.



## PREVENTIVE MAINTENANCE

- 1 . Protect pump with a suitable strainer
2. Never pump a liquid for which the pump was not designed (check with your FLO FAS representative).
3. Keep the right amount of the right lubricant in bearings at all times, Following lubrication instructions.
4. Check periodically pump and motor alignment.
5. Any down sloping towards the pump in suction piping should be corrected.
6. See that piping puts no strain on pump casing.
7. Never allow pump to run dry.
8. Examine wearing rings at regular intervals.
9. If shaft sleeves are badly scored, replace them immediately.
10. If the liquid being pumped contains grit, o separate source of sealing liquid should be used.
11. A routine maintenance schedule should be set-up to ensure an optimum inspection and service operation in order to get the best service out of your pumping equipment.

## VERTICAL IN -LINE PUMP MAINTENANCE AND SERVICE

Vertical pumps are built to operate without periodic maintenance with the exception of lubrication motor bearings with silicone grease such as Dow-Corning 44, Keystone #78 or Supermill ASU 06752 grease every 3 months. Good operational life will depend upon proper pump selection, installation and continuous water lubrication of the mechanical seals. The air vent plug must always be loosened to thoroughly vent casing before start-up and to insure water lubrication of mechanical seals.

Impurities in the system will shorten the operational life of mechanical seals due to the generally abrasive characteristics of these impurities. Most common is black iron oxide which is highly magnetic and has a tendency to fonn hard coating on all surfaces in contact with water. Water treatment is also an important factor in seal life. It is recommended that the chromate content in wafer be limited to 250 ppm.





## RENEWAL PARTS

The service for which centrifugal pump is used will determine, to a great extent, the minimum number of spare parts that should be carried in stock at the installation site. The minimum for any centrifugal pump should include:

- One set of wearing rings
- One set of shaft sleeves (or a shaft if no sleeves are used)
- One set of bearings
- Sufficient stock of spare mechanical seal
- Material For gasket

When ordering spare or repair parts, always give pump serial number and full description of part(s) required.

## WARRANTY

FLO FAB pumps are guaranteed against defective workmanship and material For a period of twelve months from date of shipment from Manufacturing Plant. Should the pump fail within this warranty period, our responsibility is limited to the repair or replacement of defective parts, provided such are returned to our Plant, transportation prepaid. We do not accept liability for damage or break-down from causes beyond our control, or the result of reasonable wear nor for repair made, or attempted to be made without prior sanction, not for any consequential damage resulting From the failure of a pump. The customer will assume all labour charges incurred in making the replacement or adjustment of the parts

PLEASE NOTE THAT THERE IS **NO GUARANTEE** ON MECHANICAL SHAFT SEALS.

## TROUBLE CHART (SEE KEY IN THE NEXT PAGE)

SYMPTOMS	POSSIBLE CAUSES
Pump does not deliver water	1, 2, 3, 4, 6, 11, 14, 16, 17, 22, 23
Insufficient capacity delivered	2, 3, 4, 5, 6, 7, 8, 9, 10, 11, 14, 17, 20, 22, 23, 29, 30, 31
Insufficient pressure developed	5, 14, 16, 18, 19, 20, 23, 24, 26, 27, 29, 33, 34, 37
Pump loses prime after starting	2, 3, 5, 6, 7, 8, 11, 12, 13
Pump requires excessive power	15, 16, 18, 19, 20, 23, 24, 26, 27, 29, 33, 34, 37
Stuffing box leaks excessively	24, 26, 32, 33, 34, 35, 36, 38, 39, 40
Packing has short life	12, 13, 24, 26, 28, 32, 33, 34, 35, 36, 37, 38, 39, 40
Pump vibrates or is noisy	2, 3, 4, 9, 10, 11, 21, 23, 24, 25, 26, 27, 28, 30, 35, 36, 41, 42, 43, 44, 45, 46, 47
Bearings have short life	24, 26, 27, 28, 35, 36, 41, 42, 43, 44, 45, 46, 47
Pump overheats and seizes	1, 4, 21, 22, 24, 27, 28, 35, 36, 41

## KEY

### SUCTION TROUBLES

1. Pump not primed.
2. Pump or suction pipe not completely filled with liquid.
3. Suction lift too high.
4. Insufficient margin between suction pressure and vapor pressure (available NPSH too low).
5. Excessive amount of air or gas in liquid.
6. Air pocket in suction line,
7. Air leakage into suction line.
8. Air leakage into pump through stuffing boxes.
9. Foot valve too small.
10. Foot valve partially clogged.
11. Inlet of suction pipe insufficiently submerged,
12. Water seal pipe plugged.
13. Seal cage improperly located in stuffing box, preventing sealing fluid entering space to form the seal.

### SYSTEM TROUBLES

14. Speed too low.
15. Speed too high.
16. Wrong direction of rotation.
17. Total head of system higher than pump design head.
18. Total head of system lower than pump design head.
19. Specific gravity of liquid different than design.
20. Viscosity of liquid differs from that for which designed.
21. Operation at very low capacity.

22. Parallel operation of pumps unsuitable for such operation.

### MECHANICAL TROUBLES

23. Foreign matter in impeller.
24. Misalignment.
25. Foundation not rigid.
26. Shaft bent.
27. Rotating part rubbing on stationary part.
28. Bearing worn.
29. Wearing rings worn.
30. Impeller damaged.
31. Casing gasket defective, permitting internal leakage.
32. Shaft or shaft sleeves worn or scored at the packing.
33. Packing improperly installed.
34. Incorrect type of packing for operation conditions.
35. Shaft running off-center due to worn bearings or misalignment.
36. Rotor out of balance resulting in vibration.
37. Gland too tight, resulting in no Flow of liquid to packing.
38. Failure to provide cooling liquid to water-cooled stuffing boxes.
39. Excessive clearance at bottom of stuffing box between shaft and casing, causing packing to be forced into pump interior.

40. Dirt or grit in sealing liquid, leading to scoring of shaft or shaft sleeve.

41. Excessive thrust caused by a mechanical Failure inside the pump or by the failure of the hydraulic balancing device, if any.
42. Excessive amount of grease or oil in the housing of on antifriction bearing or lack of cooling, causing excessive bearing temperature.
43. Lack of lubrications.
44. Improper installation of antifriction bearings (damage during assembly).
45. Dirt getting into bearings.
46. Rusting of bearings due to water getting into housing.
47. Excessive cooling of water-cooled bearing resulting in condensation in the bearing housing of moisture from the atmosphere.

# PARTS LIST FOR GV6 TYPE PUMPS CVC SERIES

## VERTICAL CENTRIFUGAL PUMP PARTS LIST

**	Part Number	Description
	1	Volute casing
x	2	Impeller
x	3	Pump Shaft
x	4	Casing Wear Ring
x	5	Shaft Sleeve
x	6	Mechanical Seal
	26	Sealing Flush Pipe
	31	Motor
	32	Bracket
	33	Motor Shaft Key
	34	Impeller washer
x	35	Impeller Bolt
x	36	Casing Gasket
	37	Motor Bolt
	40	Water Slinger

\*\* Recommended Spare Parts

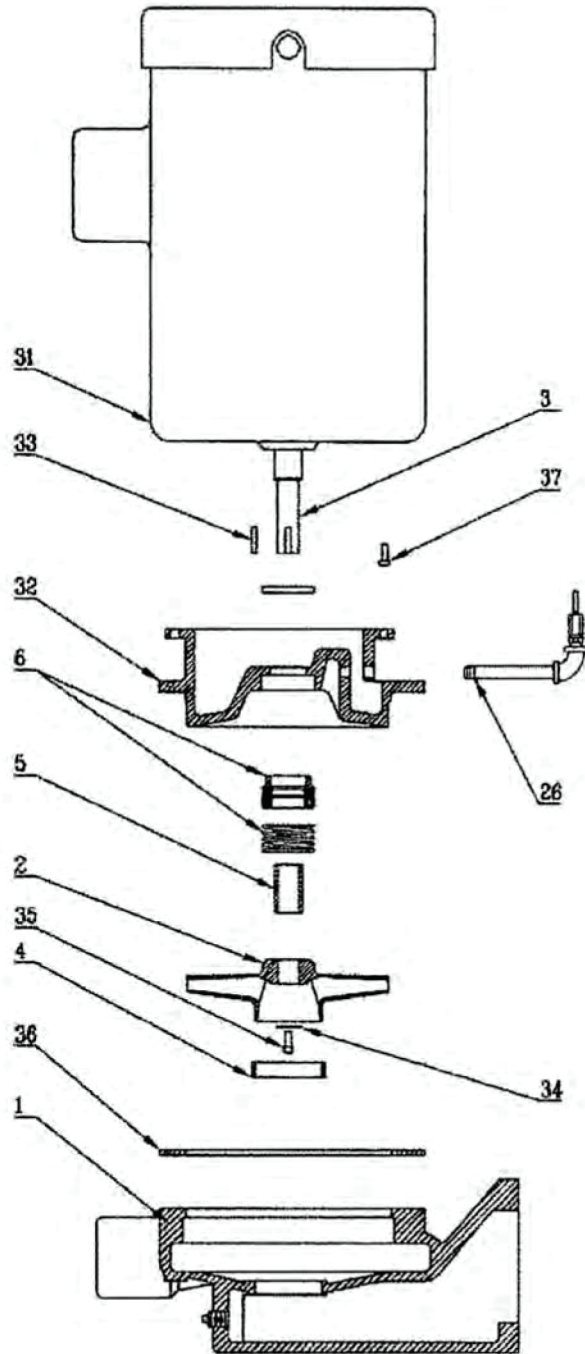

Serial #: \_\_\_\_\_

Model: \_\_\_\_\_

ID.: \_\_\_\_\_





# CONDENSATE AND BOILER FEED UNITS

## OPERATION, MAINTENANCE AND INSTALLATION MANUAL

### Selection of discharge piping

In selecting condensate pumps and making proper piping connections, the friction in the discharge line from the pump to the boiler is very important. The pressure drop due to friction is sometimes much greater than the boiler pressure. In some cases, using larger discharge piping will make it possible to use a less expensive pump with a lower pressure rating. In all cases, adequate discharge piping will mean longer life and better service from your pump. The pressure drop due to friction should always be estimated carefully, using the gallons-per-minute rating of the pump as a basis and referring to any standard pipe-friction tables or charts (be sure to make extra allowance for elbows, valves, etc.). The discharge pipe size and pump pressure rating should be selected so that the pump pressure rating will provide a generous margin of safety over and above the friction pressure drop plus the lift from pump to boiler water level (not to water inlet to boiler) plus the maximum pressure at which the boiler will operate. **Usually, the best discharge pipe size will be at least one size - sometimes two sizes - larger than the pump outlet tapping.** If possible, piping from the condensate pump outlet to the boiler inlet should be graded upward for the entire distance. In a downward run, or an 'up-and-down' run, air may be entrapped, restricting the flow of condensate. If an 'up-and-down' run cannot be avoided, it should be vented at the highest point.

### Float switch settings

When condensate pumps are tested in our factory, float switches are set according to the capacity rating. At the time of installation, the float switch should be checked to see that settings have not been disturbed during shipment and that they are correct for the particular job. The travel of the float switch between the upper (ON) position and the lower (OFF) position determines the amount of condensate delivered to the boiler each time the pump operates. At our test, the float switch is set so that the amount is equal to or a little less than the GPM rating of the pump. For example, if the pump is rated 4000 sq. ft. EDR. 6 GPM. the switch is set to deliver about 4-6 gallons at each cycle. Depending upon the water capacity of the boiler and the other characteristics of the heating system, this float switch setting may require modification for best results. If the float switch travel is too short for the job, only a small amount of condensate will be discharged each time the pump operates and consequently the motor will have to start and stop too frequently. In normal operation, it is usually undesirable for a condensate pump to start and stop more than once every three minutes. If the float switch travel is too long for the job, too much water will be discharged at each cycle. In this case, the boiler water level may fall too low before the pump starts. Then the boiler low-water cutoff will operate unnecessarily, or if there is a boiler-feed device it will supply make-up water unnecessarily and the heating system will become water-togged. If the tower (OFF) position of the float switch is too low, the pump may continue running until it loses its prime and the rotary seal may be damaged by running dry. When starting up a new pump, always check the lower float switch position to be sure that the inlet from the tank to the pump is covered with water at all times. Any condensate pump can be used for a smaller capacity than its nameplate rating by decreasing the travel of the float switch. In addition, in the case of Flo Fab series pumps, all units of the same horsepower are identical except for float switch settings. Therefore, many of these units can be used for larger capacities than the nameplate ratings by increasing the float switch travel. The «travel» as listed is the vertical displacement between the water levels at the «On» and «Off» positions of the switch. The method of adjustment is indicated in the float switch instruction sheet or card that accompanies the pump. The «travel» distance can be checked by inserting a yardstick into the vent opening at the top of the tank





## Selection

Be sure to select a pump that is big enough for the Job. Select a capacity rating adequate for the maximum amount of condensate expected under the most severe conditions. Remember that pressure rating must be sufficient to operate against maximum boiler pressure, plus lift and friction in piping between the pump and the boiler. Flo Fab pumps have rated capacities of three times the maximum flow of condensate for the specified amount of radiation; in other words, when the heating system is running at maximum capacity, the pump should not be operating more than one-third of the time. This is a minimum factor of safety. If heavy overloads are possible, an oversized condensate pump should be selected. For most applications, where the pump is above floor level and in a reasonably dry location, Flo Fab series pumps provide a wide range of selection.

## Heating plant

Locate the pump as close to the boiler as practical. A more powerful pump will be needed if it must be far away from the boiler or below the boiler. Locate the pump above floor if possible, in a position where it will be clean, dry, and easily accessible. Locate the tank inlet below the lowest point of return lines. If the pump must be below floor level, use a Flo Fab series unit with steel tank and take all possible precautions to keep the motor and electrical equipment dry. Set the pump on a substantial, level foundation - preferably off the floor, on a raised concrete base.

## Location

Before a condensate pump can operate satisfactorily, the heating plant itself must be in good order. The most important point to remember is that all heating units and return lines must be equipped with properly selected Flo Fab traps in good working order. With improper or malfunctioning steam traps, steam or water above 190°F may return to the condensate pump. For best operation, condensate should be 160°F or less. Although Flo Fab pumps can operate at higher temperatures, we cannot guarantee full capacity or satisfactory operation if condensate is allowed to go above 190°F. For unusually hot condensate, a specially designed unit may be required. It is equally important to provide Flo Fab strainers on all lines, to keep scale and dirt out of the tank and pumps.

## Pipe connections

Typical condensate pump hookups are shown in the diagrams. No two individual installations will be exactly alike, but certain essentials apply to all:

The condensate inlet should be equipped with a strainer to keep scale and dirt out of the tank, unless all return lines are exceptionally well protected with strainers. In addition, there should be some means of disposing of condensate temporarily when the condensate pump is disconnected. At the pump outlet, there should be a check valve (reasonably close to the pump) to prevent water from flowing back out of the boiler. In addition, an isolation valve should be provided for use when the pump is disconnected. The vent opening at the top of the tank must be left open to the atmosphere. Good practice is to run a pipe from the vent up to the ceiling, then down to a point near the floor drain. This keeps dirt out of the tank and helps keep the motor dry. For priming the pump when starting up or testing, a union or a plugged tee at the vent opening is desirable. Many variations in piping arrangements are possible: and local codes vary widely. For example, in some cities there must be a bypass around the condensate pump with gate valves, so that the return line can be connected directly to the boiler when the pump is disconnected.



## Electrical connections

Check the motor characteristics (phase, cycles, voltage) to be certain that they are correct for your power supply; otherwise you may burn out the motor by running it on too high a voltage.

Be sure that only a qualified electrician makes the electrical connections to the pump. With small, single phase units, the pump motor is commonly controlled directly by the float switch. On three-phase units, the float switch operates a motor starter, which starts and stops the pump motor.

When a pump with a make-up water valve is used, the pump motor is controlled by a boiler water level control

Make-up Water Valve: Mechanical, plug mounted valve with stainless steel float. Rated up to 45 PSI inlet water pressure. At pressures exceeding 45 PSI, a PRV is required on the inlet cold water line.

Be sure that all wiring is well protected from moisture.

Be sure that the motor is connected so that the pump rotates in the correct direction.

## Starting and operating

Do not operate the pumps without priming. If the pumps are run dry, even for a very short time, they may be severely damaged. Be sure to keep the motor dry. **WHEN STARTING UP A PUMP, ALWAYS ROTATE IT BY HAND TO BE SURE IT TURNS FREELY, BEFORE TURNING ON POWER.**

## Troubleshooting

### **Motor overheats or burns out, or pump does not deliver enough condensate to boiler or pump runs continuously or almost continuously:**

1. Check the capacity and pressure rating of the pump; it may be too small for the job.
2. Check the temperature of condensate; the pump may not handle it if it is too hot.
3. Check the float switch; it may be damaged and jammed in the "on" position.
4. Check the lines and valves between the pump and boiler for clogging; check the pump for clogging.

### **Pumps starts and stops too frequently:**

1. Check the float switch adjustment; too little travel between «on» and «off» positions.

### **Pump does not start until after boiler water falls below safe level:**

1. Check the float switch adjustment; too little travel between «on» and «off» positions.

### **Pump makes excessive noise:**

1. Has the pump been damaged by operating without prime or with hot condensate (Above 190°F)?
2. Is the pump on a substantial foundation? Is a sounddeadening base required?
3. Is the noise being transmitted through piping? If so, short lengths or hose connected in delivery and return lines will usually improve conditions greatly..

### **Pumps leaks:**

1. Unit may have been disassembled and reassembled improperly.
2. The rotary seal may be worn or scored or may have been installed improperly. If worn, has this been caused by abrasive material in lines?





## Terms and Conditions

*Our acceptance of your order is expressly conditioned on the general terms and conditions set forth below and all terms stated on the face of this form. The contract shall not include any deviating or additional terms unless expressly agreed to in writing and signed by an officer of our company.*

**PRICES:** All prices are subject to change without notice and all shipments will be invoiced at the price in effect at the time of shipment, except when otherwise agreed to in writing by our authorized representative. Published prices are for products of our standard design and construction and any item not covered by the most recent published price list must be referred to us for special pricing. Prices do not include freight. Weights shown in price lists are approximate shipping weights. The amount of any applicable present or future tax or other government charge upon the production, sale, shipment or use of goods ordered or sold is not in the price and will be added to billing unless you provide us with an appropriate exemption certificate.

**QUOTATION:** Prices quoted by us are valid for 30 days from date of quotation unless we have otherwise specified in writing. Clerical errors on quotations are subject to our correction and such errors will not be binding.

**CANCELLATION & REVISIONS:** No purchase orders accepted and acknowledged by us may be cancelled or revised by you except with our prior written consent and upon payment of reasonable cancellation charges compensating us for all costs incurred in work done and material purchased. We reserve the right to determine what constitutes reasonable cancellation charges.

**RETURN OF EQUIPMENT:** No equipment shall be returned to us without first obtaining a written Returned Goods Authorization and shipping instruction from us. The returner must prepay the charges in full for transportation to our factory. Credit allowed for new, undamaged equipment of current standard design will be 80% of the invoiced price or current billing price, whichever is less. Equipment which has been used, however slight, will not be accepted. Authorization will not be given for return of equipment, (1) which would, in our opinion, result in an excess in the amount of stock we normally carry, (2) not invoiced within the last 3 months, or (3) which is non-standard and manufactured specifically to a buyer's specifications. For non-standard equipment not of our manufacture, the only credit allowed will be such credit as may be allowed by the manufacturer of such equipment. Equipment must be returned within 30 days of the issuance of the Returned Goods Authorization. No item with a net value of less than \$50.00 will be authorized for return. Unauthorized returns may be refused and/or returned freight collect.

**CREDIT & PAYMENT:** Payment is due as noted on our invoice. Overdue accounts are subject to a service charge. All orders are subject to approval of our credit department and we may require full or partial payment in advance. Pro rata payments shall become due as shipments are made. If the shipments are delayed by you for any cause, payments shall become due from date on which we are prepared to make shipment and storage shall be at your risk and expense. If manufacture is delayed by you for any

cause, a partial payment based upon the proportion of the order completed shall become due from the date on which we are notified of the delay.

**SECURITY INTEREST:** We shall have a lien on all goods sold as security for payment on the invoice price, and upon request you shall provide and execute a financing statement showing such lien.

**DELIVERY:** We will reasonable effort to meet your delivery requirement provided you provide us, on a timely basis, all approvals, technical data, instructions and credit approval requirements needed for release of the shipment. However, all delivery and/or shipment dates are estimates only unless we have expressly guaranteed delivery of such dates in writing at your specific request. In no event shall we have any liability if delivery is delayed by strikes, labour disturbances, material shortages, plant calamities or disaster, acts of God, government actions, civil disturbance, the failure of any pre-supposed condition of the contract, withholding shipments due to credit clearance, or other interferences beyond our reasonable control, and the date of delivery shall be extended for a period of time equal to the time lost because of any such reason.

**SHIPPING:** Unless you specify in writing and we acknowledge in writing, (A) goods will be boxed or crated as we may deem proper for protection against normal handling and for domestic shipment, (B) routing and manner of shipment will be at our discretion, and may be insured at your expense. An extra charge will be made for special handling. All shipments are F.O.B. point of manufacture. Delivery of goods to the initial carrier will constitute delivery to you and all goods will be shipped at your risk. A claim for loss or damage in transit must be entered with the carrier and prosecuted by you. Acceptance of material from a common carrier constitutes a waiver of any claims against us for delay, damage or loss.

**GOVERNING LAW:** It is understood and agreed that these Terms and Condition of Sale shall be interpreted under and pursuant to the laws of the Province of Quebec; you agree that any action at law which is related to any contract of sale brought against the company shall be filed in the appropriate court located in the Province of Quebec.

**PROJECT:** \_\_\_\_\_  
**CONTRACTOR:** \_\_\_\_\_  
**ENGINEER:** \_\_\_\_\_  
**DATE:** \_\_\_\_\_







## Terms and Conditions

**LIMITED WARRANTY:** We warrant to our immediate customer and to the ultimate consumer that products of our manufacture will be free of defects in material and workmanship under normal use and service for the following time periods, when installed and maintained in accordance with our instructions. Pumps Products: One (1) year from date of invoicing. As used herein, "the ultimate consumer" is defined as the purchaser who first uses the product after its initial installation or, in the case of product designed for non permanent installation, the first owner who used the product. It is the purchaser's or any sub-vendee's obligation to make known to the ultimate consumer the terms and conditions of this warranty. This warranty gives you specific legal rights, and there may also be other rights which vary from province to province. In the event the product is covered by the Consumer Product Warranty (1) the duration of any implied warranty associated with the product by virtue of said law is limited to the same duration as stated herein, (2) this warranty is a LIMITED WARRANTY, and (3) no claims of any nature whatsoever shall be made against us, until the ultimate consumer, his successor, or assigns, notifies us in writing of the defect, and delivers the product and/or defective part(s) freight prepaid to our factory or nearest authorized service station. THE SOLE AND EXCLUSIVE REMEDY FOR BREACH OF ANY AND ALL WARRANTIES WITH RESPECT TO ANY PRODUCT SHALL BE TO REPLACE OR REPAIR AT OUR ELECTION, F.O.B. POINT OF MANUFACTURE OR AUTHORIZED REPAIR STATION, SUCH PRODUCTS AND/OR PARTS REPAIR STATION, SUCH PRODUCTS AND/OR PARTS AS PROVEN DEFECTIVE. THERE SHALL BE NO FURTHER LIABILITY, WHETHER BASED ON WARRANTY, NEGLIGENCE OR OTHERWISE. Unless expressly stated otherwise guarantees in the nature of performance specifications furnished in addition to the foregoing material and workmanship warranties on a product manufactured by us, if any, are subject to laboratory tests corrected for field performance. Any additional guarantees, in the nature of performance specifications must be in writing and such writing must be signed by our authorized representative. Due to inaccuracies in field testing if a conflict arises between the results of field testing conducted by or for user, and laboratory test corrected for field performance, the latter shall control. Components or accessories supplied by us but manufactured by others are warranted only to the extent of and by the terms and conditions of the original manufacturer's warranty. RECOMMENDATIONS FOR SPECIAL APPLICATIONS OR THOSE RESULTING FROM SYSTEMS ANALYSES AND EVALUATIONS WE CONDUCT WILL BE BASED ON OUR BEST AVAILABLE EXPERIENCE AND PUBLISHED INDUSTRY INFORMATION. SUCH RECOMMENDATIONS DO NOT CONSTITUTE A WARRANTY OF SATISFACTORY PERFORMANCE AND NO SUCH WARRANTY IS GIVEN. This warranty shall not apply when damage is caused by (A) improper installation, (B) improper voltage (C) lightning (D) sand or other abrasive material (E) scale or corrosion build-up due to excessive chemical content. Any modification of the original equipment will also void the warranty. We will not be responsible for loss, damage or labour cost due to interruption of service caused by defective parts. Neither will we accept charges incurred by others without our prior written approval. This warranty is void if our inspection reveals the product was in a manner inconsistent with normal industry practice and/or our specific recommendations.

The purchaser is responsible for communication of all necessary information regarding the application and use of the product. UNDER NO CIRCUMSTANCES WILL BE RESPONSIBLE FOR ANY OTHER DIRECT OR CONSEQUENTIAL DAMAGES, INCLUDING BUT NOT LIMITED TO LOST PROFITS, LOST INCOME, LABOUR CHARGES, DELAYS IN PRODUCTION, IDLE PRODUCTION, WHICH DAMAGES ARE CAUSED BY ANY DEFECTS IN MATERIAL AND/OR WORKMANSHIP AND/OR DAMAGE OR DELAYS IN SHIPMENT. THIS WARRANTY IS EXPRESSLY IN LIEU OF ANY OTHER EXPRESS OR IMPLIED WARRANTY, INCLUDING ANY WARRANTY OF MERCHANTABILITY OR FITNESS FOR A PARTICULAR PURPOSE. No rights extended under this warranty shall be assigned to any other person, whether by operation of law or otherwise, without our prior written approval. If any litigation is commenced between the parties hereto for the enforcement of any rights hereunder, the successful party in subject litigation shall be entitled to receive from the unsuccessful party all costs incurred in connection therewith, including a reasonable amount of attorney's fees. YOUR ACCEPTANCE OF ANY GOODS SUPPLIED BY US, OR ON OUR BEHALF, SHALL, WITHOUT LIMITATION CONSTITUTE ACCEPTANCE OF ALL TERMS AND CONDITIONS STATED ABOVE.

**PROJECT:** \_\_\_\_\_  
**CONTRACTOR:** \_\_\_\_\_  
**ENGINEER:** \_\_\_\_\_  
**DATE:** \_\_\_\_\_





We are proud supplier for the following completed and on going projects :



**Peruvian Park Elementary**  
1545 E 8425 S, Sandy,  
UT, US



**Greenbush Elementary School**  
127 Greenbush Rd, West  
Warwick, RI, US



**Canadian National**  
935 De la Gauchetiere  
Street W, Montreal QC, CA



**Montreal's Archives**  
535 Viger Street E,  
Montreal, QC, CA

## Sales and Service:

Quebec, Canada  
Tel. : (450) 621-2995  
Fax : (450) 621-4995

Lake Worth  
Florida, USA  
33467-5749

Toronto, Canada  
Tel. : +1 (647) 544-2995

[www.flofab.com](http://www.flofab.com)

SERVICE 24/7 : [parts@flofab.com](mailto:parts@flofab.com)

