

## MODELS



FloFab Model No.	Description	HP	120v		220v		380v		400v	
			Start A.	Run. A.	Start A.	Run. A.	Start A.	Run. A.	Start A.	Run. A.
LB-25	3/4", 0.25Kw, 1 phase	1/3 HP	18	3.6	9.5	1.9				
LB-40	2", 0.40kw, 1 phase	1/2HP	25.5	5.1	13.5	2.7				
LB-40T	2", 0.40kw, 3 phase	1/2HP			8.5	1.7	5.5	1.1	5.5	1.1
LB-75	2", 0.75kw, 1 phase	1HP	48.5	9.7	27.5	5.5				
LB-75T	2", 0.75kw, 3 phase	1HP			17.5	3.5	10	2	9.5	1.9
LB-215/315	2"3", 1.5kw, 1 phase	2HP	95	19	53.5	10.7				
LB-215T/315T	2"3", 1.5kw, 3 phase	2HP			32.5	6.5	20	4	19	3.8
LBV-40	2", 0.40kw, 1 phase	1/2HP	25.5	5.1	13.5	2.7				
LBV-40T	2", 0.40kw, 3 phase	1/2HP			8.5	1.7	5.5	1.1	5.5	1.1
LBV-75	2", 0.75kw, 1 phase	1HP	48.5	9.7	27.5	5.5				
LBV-75T	2", 0.75kw, 3 phase	1HP			17.5	3.5	10	2	9.5	1.9
LBV-208/308	3", 0.75kw, 1 phase	1 HP	48.5	9.7	27.5	5.5				
LBV-215/315	3", 1.5kw, 1 phase	2HP	95	19	53.5	10.7				
LBV-215T/315T	3", 1.5kw, 3 phase	2HP			32.5	6.5	20	4	19	3.8
LBV-322	3", 2.2kw, 3 phase	3HP			47.5	9.5	29	5.8	110	5.5
LBV-337	3", 3.7kw, 3 phase	5HP			78.5	15.7	46	9.2	44	8.8
LBV-455	4", 5.5kw, 3 phase	7.5HP			118	23.6	68.5	13.7	65.5	13.1
LBV-475	4", 7.5kw, 3 phase	10HP			157.5	31.5	90.5	18.1	86	17.2
LBVSS-75	2", 0.75kw, 1 phase	1HP	48.5	9.7	27.5	5.5				
LBVSS-75T	2", 0.75kw, 3 phase	1HP			17.5	3.5	10	2	9.5	1.9
LBVSS-215	2", 1.5kw, 1 phase	2HP	95	19	53.5	10.7				
LBVSS-215T	2", 1.5kw, 3 phase	2HP			32.5	6.5	31.5	6.3	12.5	2.5
LBK-75	2", 0.75kw, 1 phase	1HP	48.5	9.7	27.5	5.5				
LBK-75T	2", 0.75kw, 3 phase	1HP			17.5	3.5	10	2	9.5	1.9
LBK-215/315	2"3", 1.5kw, 1 phase	2HP	95	19	53.5	10.7				
LBK-215T/315T	2"3", 1.5kw, 3 phase	2HP			32.5	6.5	31.5	6.3	12.5	2.5
LBC-75	2", 0.75kw, 1 phase	1HP	48.5	9.7	27.5	5.5				
LBC-75T	2", 0.75kw, 3 phase	1HP			17.5	3.5	10	2	9.5	1.9
LBC-215/315	2"3", 1.5kw, 1 phase	2HP	95	19	53.5	10.7				
LBC-215T/315T	2"3", 1.5kw, 3 phase	2HP			32.5	6.5	31.5	6.3	12.5	2.5
FBV-322	3", 2.2kw, 3 phase	3HP			47.5	9.5	29	5.8	110	5.5
FBV-337	3", 3.7kw, 3 phase	5HP			78.5	15.7	46	9.2	44	8.8
FBV-437	4", 3.7kw, 3 phase	5HP			78.5	15.7	46	9.2	44	8.8
FBV-455	4", 5.5kw, 3 phase	7.5HP			118	23.6	68.5	13.7	65.5	13.1
FBV-475	4", 7.5kw, 3 phase	10HP			157.5	31.5	90.5	18.1	86	17.2
FBK-322	3", 2.2kw, 3 phase	3HP			47.5	9.5	29	5.8	110	5.5
FBK-337	3", 3.7kw, 3 phase	5HP			78.5	15.7	46	9.2	44	8.8
FBK-437	4", 3.7kw, 3 phase	5HP			78.5	15.7	46	9.2	44	8.8
FBC-322	3", 2.2kw, 3 phase	3HP			47.5	9.5	29	5.8	110	5.5
FBC-337	3", 3.7kw, 3 phase	5HP			78.5	15.7	46	9.2	44	8.8
FBC-437	4", 3.7kw, 3 phase	5HP			78.5	15.7	46	9.2	44	8.8
FGC-11	1-1/4", 1.1kw, 1 phase	1.5HP	95	19	53.5	10.7				
FGC-11T	1-1/4", 1.1kw, 3 phase	1.5HP			32.5	6.5	20	4	19	3.8
FGC-15	1-1/4", 1.5kw, 1 phase	2HP			80	16				
FGC-15T	1-1/4", 1.5kw, 3 phase	2HP			47.5	9.5	29	5.8	110	5.5
FGC-22	2", 2.2kw, 3 phase	3HP			47.5	9.5	29	5.8	110	5.5
FGC-37	2", 3.7kw, 3 phase	5HP			78.5	15.7	46	9.2	44	8.8
FGC-55	2", 5.5kw, 3 phase	7.5HP			118	23.6	68.5	13.7	65.5	13.1
FNC-337/437	3"4", 3.7kw, 3 phase	5HP			78.5	15.7	46	9.2	44	8.8
FNC-455/655	4"6", 5.5kw, 3 phase	7.5HP			118	23.6	68.5	13.7	65.5	13.1
FNC-475/675	4"6", 7.5kw, 3 phase	10HP			157.5	31.5	90.5	18.1	86	17.2
FNC-4110/6110	4"6", 11kw, 3 phase	15HP			236.5	47.3	137	27.4	130	26
FNC-4150/6150	4"6", 15kw, 3 phase	20HP			315	63	182.5	36.5	173.5	34.7
FNC-4220/6220	4"6", 22kw, 3 phase	30HP			472.5	94.5	273.5	54.7	260	52
TBV-A-322	3", 2.2kw, 3 phase	3HP			47.5	9.5	29	5.8	110	5.5
TBV-A-337	3", 3.7kw, 3 phase	5HP			78.5	15.7	46	9.2	44	8.8

## MODELS



FloFab Model No.	Description	HP	120v		220v		380v		400v	
			Start A.	Run. A.	Start A.	Run. A.	Start A.	Run. A.	Start A.	Run. A.
FS-400	2", 0.4kw, 1 phase	1/2HP	25,5	5,1	13,5	2,7				
FS-400T	2", 0.4kw, 3 phase	1/2HP			8,5	1,7	5,5	1,1	5,5	1,1
FS-750	2", 0.75w, 1 phase	1HP	48,5	9,7	27,5	5,5				
FS-750T	2", 0.75w, 3 phase	1HP			17,5	3,5	10	2	9,5	1,9
FS-1500	2", 1.5kw, 1 phase	2HP	95	19	53,5	10,7				
FS-1500T	2", 1.5kw, 3 phase	2HP			32,5	6,5	20	4	19	3,8
FS-215/315T	2"/3", 1.5kw, 3 phase	2HP			32,5	6,5	20	4	19	3,8
FS-222/322/422	2"/3"/4", 2.2kw, 3 phase	3HP			47,5	9,5	29	5,8	110	5,5
FS-237/337/437	2"/3"/4", 3.7kw, 3 phase	5HP			78,5	15,7	46	9,2	44	8,8
FS-355/455	3"/4", 5.5kw, 3 phase	7.5HP			118	23,6	68,5	13,7	65,5	13,1
FS-475N/675N	4"/6", 7.5kw, 3 phase	10HP			157,5	31,5	90,5	18,1	86	17,2
FS-3110	3", 11kw, 3 phase	15HP			236,5	47,3	137	27,4	130	26
FS-4110/6110	4"/6", 11kw, 3 phase	15HP			236,5	47,3	137	27,4	130	26
FS-4150/6150	4"/6", 15kw, 3 phase	20HP			315	63	182,5	36,5	173,5	34,7
FS-4220/6220/8220	4"/6"/8", 22kw, 3 phase	30HP			472,5	94,5	273,5	54,7	260	52
FSS-400	2", 0.40kw, 1 phase	1/2HP	25,5	5,1	13,5	2,7				
FSS-400T	2", 0.40kw, 3 phase	1/2HP			8,5	1,7	5,5	1,1	5,5	1,1
FSS-750	2", 0.75kw, 1 phase	1HP	48,5	9,7	27,5	5,5				
FSS-750T	2", 0.75kw, 3 phase	1HP			17,5	3,5	10	2	9,5	1,9
FSS-215	2", 1.5kw, 1 phase	2HP	95	19	53,5	10,7				
FSS-215T	2", 1.5kw, 3 phase	2HP			32,5	6,5	20	4	19	3,8
FSS-315	3", 1.5kw, 1 phase	2HP	95	19	53,5	10,7				
FSS-315T	3", 1.5kw, 3 phase	2HP			32,5	6,5	20	4	19	3,8
FSH-6370/8370	6"/8", 37kw, 3 phase	50HP					456	91,2	433	86,6
FSH-6450/8450	6"/8", 45kw, 3 phase	60HP					547,5	109,5	520	104
SLIM-380	3", 8kw, 1 phase	11 HP			173,5	34,7	99	19,8	94,5	18,9



# SEWAGE PUMPS

DRAINAGE PUMPS  
 VORTEX SEWAGE PUMPS  
 NON-CLOG PUMPS  
 CUTTER PUMPS

GRINDER PUMPS  
 SINGLE CHANNEL PUMPS  
 VORTEX & AGITATOR PUMPS

## COMMON FEATURES

### 1 Watertight Cable Entry

The cable entry employs an anti-wicking block where each conductor is stripped and encapsulated in epoxy. This feature effectively prevents water from penetrating the motor chamber when the cable end is submerged or the cable sheath is damaged.

### 2 Motor Protector

The motor incorporates a motor protection device which protects against overheating and dry-run. Pumps with a capacitor-run or direct-on line starting motor are equipped with a circle thermal protector. Pumps with a start-delta starting motor are equipped with miniature thermal protectors in each phase.

### 3 Submersible Motor

Air filled motor, housed in a watertight casing, conforms to Class F insulation.

### 4 C3 Ball Bearings and Hardened SS Shaft

High quality of C3 ball bearings and the well-balanced, hardened stainless steel shaft enhance stability during continuous pumping operations.

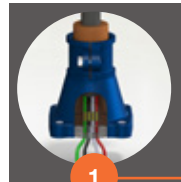

Anti-wicking

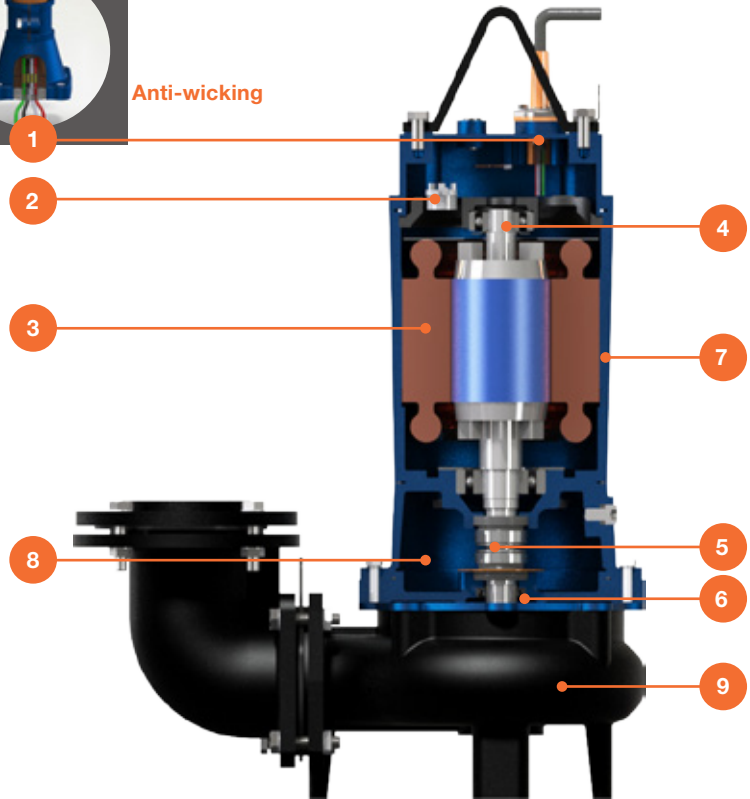

### 5 Double Mechanical Seals

Located in the oil chamber, the device is made of quality materials with highly wear-resistant silicon carbide in lower side that provides extra protection against leakage and dry-run.

### 6 Extra Protection for Mechanical Seals and Shaft

Lip seals and shaft sleeves are utilized for additional protection against wear.

### 7 Rugged Cast Iron Design

The whole cast iron pump features a simple, robust structure that provides durability and impact resistance to rough conditions.

### 8 Food Grade Lubricant

FLO FAB adopts eco-friendly lubricant to minimize environmental impacts.

### 9 Impellers and Volutes

Types of impellers and volutes are varied with pump models, cultivated through years of experience in the pump manufacturing industry.

They include single channel impellers, vortex impellers, semi-open impellers, grinders, and agitators.





# LB 25

## HANDY & RESIDUE PUMPS

The LB 25 pump is suitable for a variety of domestic applications, including draining basements and garages, emptying swimming pool and fountains, gardening, and hobby applications in general.

- Compact, lightweight, and easy-to-use design
- Stainless Steel 304 motor housing with lightweight top cover, pump casing, impeller, and suction grids.
- Air filled motor with Class F insulation.
- Thermal protection on motor.
- Built-in high torque capacitor.
- Triple seals design.
- Removable filter screen for easy maintenance.

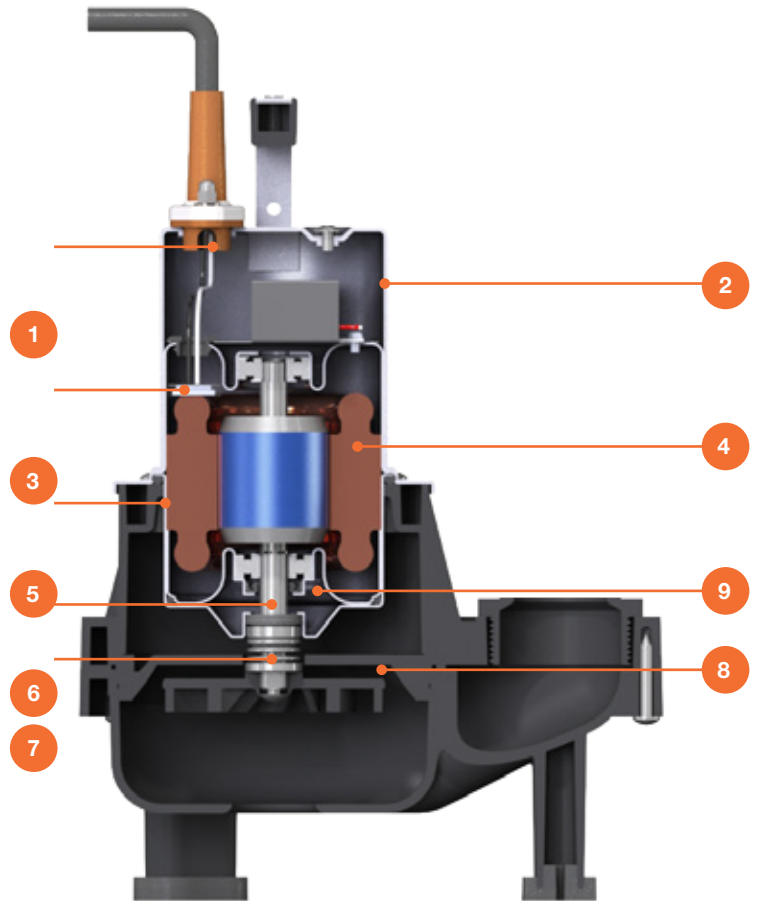

### FEATURES

#### 1 Watertight Cable Entry

Watertight cable entry prevents water incursion from the capillary wicking.

#### 2 Durable Outer Housing

The outer housing made of 304 stainless steel provides impact resistant to harsh handling and conditions.

#### 3 Motor Protector

The motor incorporates a miniature thermal protector which protects against overheating and dry-run.

#### 4 Submersible Motor

Air filled motor, housed in a watertight casing, conforms to Class F insulation.

#### 5 Stainless Steel 304 Motor Housing

The material provides superior corrosion resistance.

#### 6 C3 Ball Bearings and Hardened SS Shaft

High quality of C3 ball bearings and the well-balanced, hardened stainless steel shaft enhance stability during continuous pumping operations.

#### 7 Mechanical Seal

The premium mechanical seal provides extra protection against leakage and longer life span.

#### 8 Impact-resistant Nylon pump casing and suction grid

Lightweight design and corrosion-resistance.

#### 9 Food Grade Lubricant

FLO FAB adopts eco-friendly lubricant to minimize environmental impacts.

## LB SERIES DRAINAGE PUMPS

**Discharge Bore :** 50 - 80 mm

**Motor :** 0.25 ~ 0.75 kW

**Impeller Type :** Semi-Open impeller

**Features :** Offering high performance in various effluent pumping applications.

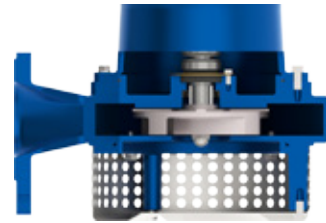

## LBV - FBV SERIES VORTEX PUMPS

**Discharge Bore :** 50 - 100 mm

**Motor :** 0.4 ~ 7.5 kW

**Impeller Type :** Vortex impeller

**Features :** A whirling action enables large solids and fibrous matters to be pumped out without obstruction.

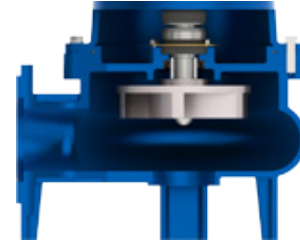

## LBK - FBK SERIES NON-CLOG PUMPS

**Discharge Bore :** 50 - 100 mm

**Motor :** 0.4 ~ 2.2 kW

**Impeller Type :** Semi-Open Channel impeller

**Features :** Wide channel allows solids passing with minimal blockage.

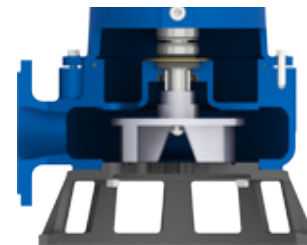

## LBC - FBC SERIES CUTTER PUMPS

**Discharge Bore :** 50 - 100 mm

**Motor :** 0.4 ~ 2.2 kW

**Impeller Type :** Semi-Open Channel Cutter impeller

**Features :** Utilizing a cutter mechanism and tungsten carbide alloy to cut fibrous matters and to prevent clogging.

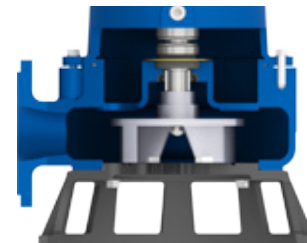

## FGC SERIES GRINDER PUMPS

**Discharge Bore :** 32 - 50 mm

**Motor :** 0.75 ~5.5 kW,

**Impeller Type :** Vortex impeller

**Features :** Employing a grinding mechanism to prevent clogging, especially ideal for narrow sewer.

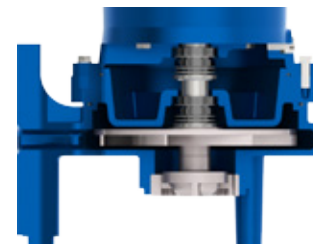

## FNC SERIES SINGLE CHANNEL PUMPS

**Discharge Bore :** 80 - 150 mm

**Motor :** 3.7 ~ 22 kW

**Impeller Type :** Single Channel impeller

**Features :** Passing 76mm diameter solids without clogging.

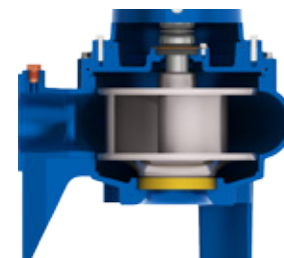

## TBV SERIES VORTEX & AGITATOR PUMPS

**Discharge Bore :** 80 mm

**Motor :** 1.5~ 2.2 kW

**Impeller Type :** Vortex impeller

**Features :** Coupled with an agitator, which significantly and efficiently improves solids handling.

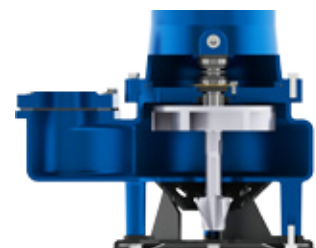



## GUIDE RAIL FITTING SYSTEMS

The guide rail fitting system connects the pump to and from the piping simply just by lowering and elevating the pump.

The mechanism allows easy maintenance and inspection without the need to enter the sump. Pump models used in combination with the guide rail fitting system can be identified by the following index and reference.

Available upon request.





# STAINLESS STEEL PUMPS

## DEWATERING & SEWAGE VORTEX

FLOFAB stainless steel pumps consist of four dewatering pumps (FSS-400-750-215 -315) and two sewage pumps LBVSS75-215). All components in contact with the liquid are made of 304 stainless steel.

These pumps are designed for handling clean water or screened wastewater, also applicable to the aquaculture industry with the use of the food-grade lubricant.

### FEATURES

#### 1 Watertight Cable Entry

The cable entry employs an anti-wicking block where each conductor is stripped and encapsulated in epoxy. This feature effectively prevents water from penetrating the motor chamber when the cable end is submerged or the cable sheath is damaged.

#### 2 Top Discharge and Double Housing Design

Designed to construct a water jacket that provides maximum motor cooling effect for continuous operation at low water level, this feature forms the cylindrical and slim shape of the pump and enables the pump to be installed in confined spaces.

#### 3 Motor Protector

The motor incorporates a circle thermal protector which protects against overheating and dry-run.

#### 4 Submersible Motor

Air filled motor, housed in a watertight casing, conforms to Class F insulation.

#### 5 C3 Ball Bearings and Hardened SS Shaft

High quality of C3 ball bearings and the well-balanced, hardened stainless steel shaft enhance stability during continuous pumping operations.

#### 6 Double Mechanical Seals

Located in the oil chamber, the device is made of quality materials with highly wear-resistant silicon carbide in lower side that provides extra protection against leakage and dry-run.

#### 7 Extra Protection for Mechanical Seals and Shaft

Lip seals and shaft sleeves are utilized for additional protection against wear.

#### 8 Food Grade Lubricant

FLO FAB adopts eco-friendly lubricant to minimize environmental impacts.

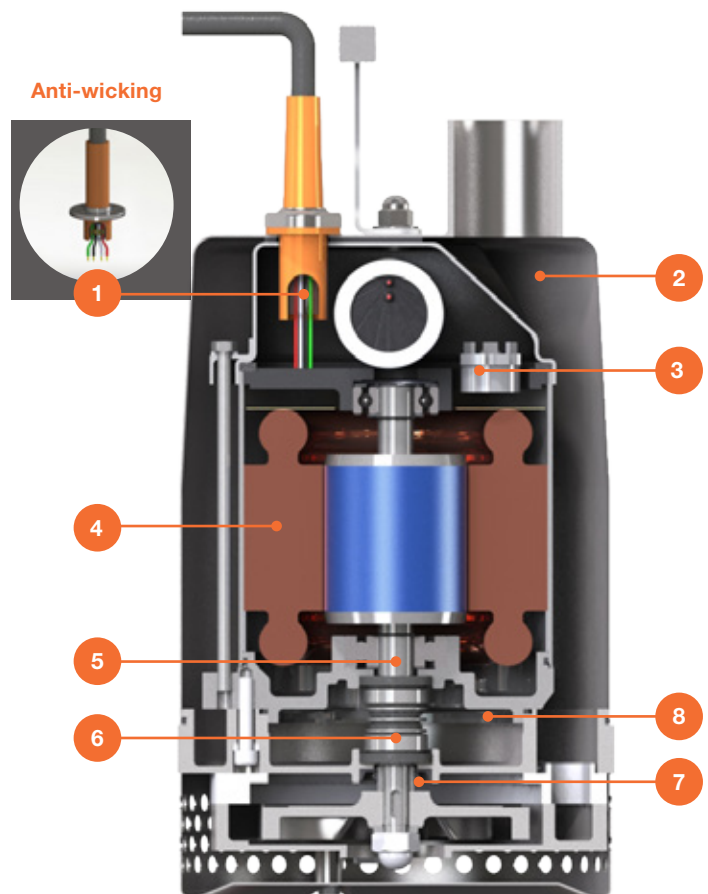

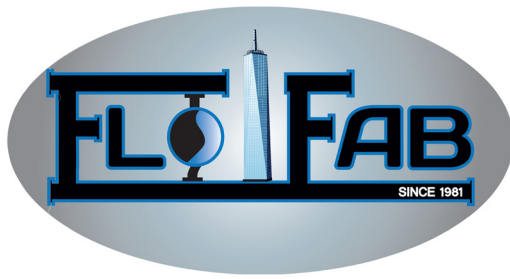

# FS SERIES

## HANDY & RESIDUE PUMPS

Compact, lightweight and easy to use, the FS handy & residue series pumps (FS-400-750-1500) deliver high performance for their size. These small but effective dewatering pumps are easily maintained and perfect for a variety of applications, such as small construction sites, rental industries, and municipal jobs.

### FEATURES

- 1 Watertight Cable Entry**  
The cable entry employs an anti-wicking block where each conductor is stripped and encapsulated in epoxy. This feature effectively prevents water from penetrating the motor chamber when the cable end is submerged or the cable sheath is damaged.
- 2 Top Discharge and Double Housing Design**  
Designed to construct a water jacket that provides maximum motor cooling effect for continuous operation at low water level, this feature forms the cylindrical and slim shape of the pump and enables the pump to be installed in confined spaces.
- 3 Motor Protector**  
The motor incorporates a circle thermal protector which protects against overheating and dry-run.
- 4 Submersible Motor**  
Air filled motor, housed in a watertight casing, conforms to Class F insulation.
- 5 C3 Ball Bearings and Hardened SS Shaft**  
High quality of C3 ball bearings and the well-balanced, hardened stainless steel shaft enhance stability during continuous pumping operations.
- 6 Double Mechanical Seals**  
Located in the oil chamber, the device is made of quality materials with highly wear-resistant silicon carbide in lower side that provides extra protection against leakage and dry-run.
- 7 Extra Protection for Mechanical Seals and Shaft**  
Lip seals and shaft sleeves are utilized for additional protection against wear.
- 8 Durable Outer Jacket and Strainer**  
The outer housing and strainer made of 304 stainless steel provide impact resistant to harsh handling and conditions.
- 9 Food Grade Lubricant**  
FLO FAB adopts eco-friendly lubricant to minimize environmental impacts.

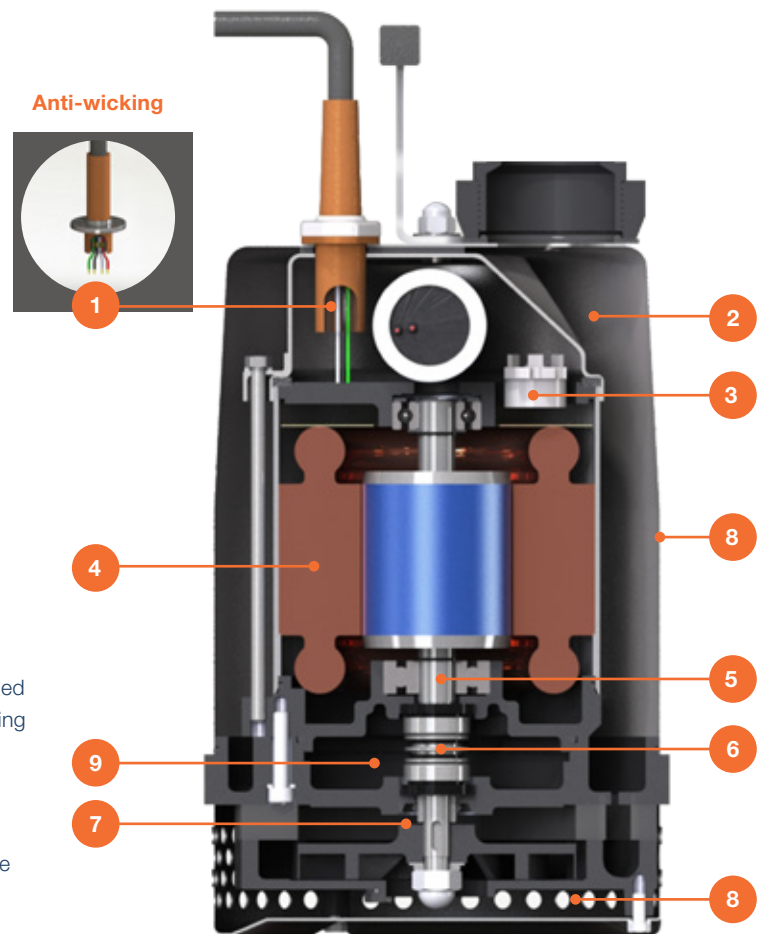





# FS SERIES

## HIGH CHROME DEWATERING PUMP

Designed for continuous operations, excellent performance and easy maintenance, FLO FAB FS series pumps have proven their reliability and durability in demanding areas like construction, mining, tunneling, quarries, industries and rental applications.

### FEATURES

- 1 Watertight Cable Entry**  
The cable entry employs an anti-wicking block where each conductor is stripped and encapsulated in epoxy. This feature effectively prevents water from penetrating the motor chamber when the cable end is submerged or the cable sheath is damaged.
- 2 Multi-Direction Discharge Coupling**  
Discharge can be converted between vertical and horizontal directions. In pumps 7.5 HP and larger, a vertical discharge connection is supplied as standard.
- 3 Motor Protector**  
The motor incorporates a circle thermal protector which protects against overheating and dry-run.  
**Top Discharge and Double Housing Design**  
Designed to construct a water jacket that provides maximum motor cooling effect for continuous operation at low water level, this feature forms the cylindrical and slim shape of the pump and enables the pump to be installed in confined spaces.
- 5 Submersible Motor**  
Air filled motor, housed in a watertight casing, conforms to Class F insulation.
- 6 C3 Ball Bearings and Hardened SS Shaft**  
High quality of C3 ball bearings and the well-balanced, hardened stainless steel shaft enhance stability during continuous pumping operations.

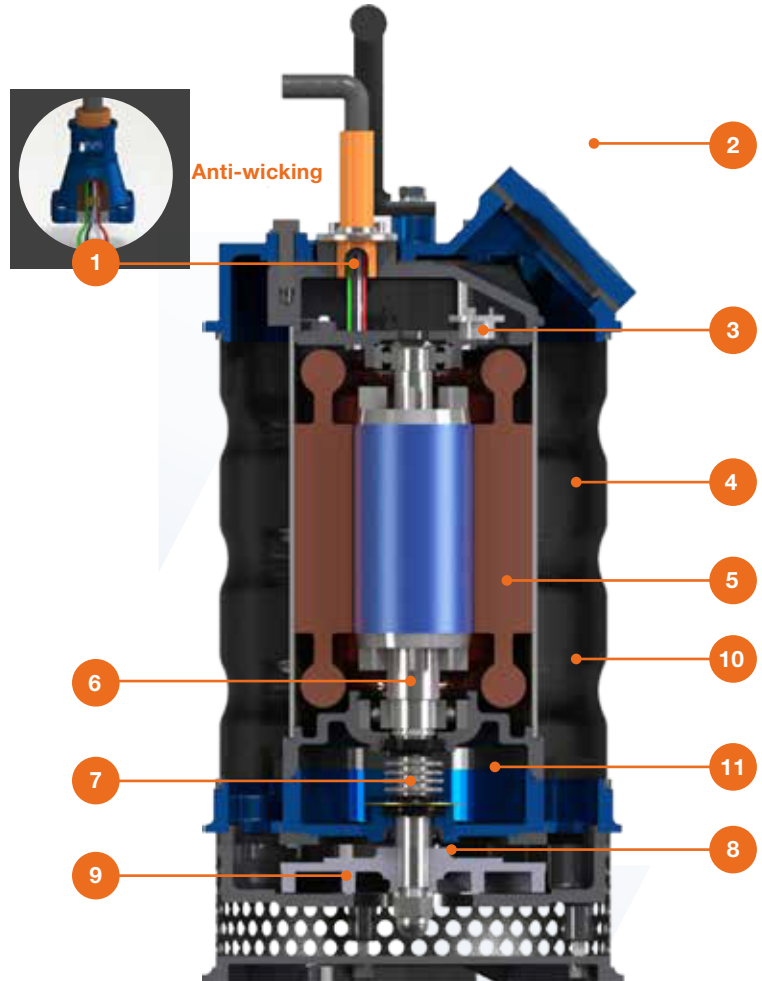

The above images are for illustration purposes only, please refer to datasheets for more details.

- 7 Double Mechanical Seals**  
Located in the oil chamber, the device is made of quality materials with highly wear-resistant silicon carbide in lower side that provides extra protection against leakage and dry-run.
- 8 Extra Protection for Mechanical Seals and Shaft**  
Lip seals and shaft sleeves are utilized for additional protection against wear.
- 9 High Chrome Iron Impeller**  
FLO FAB patent formula, ACRS Tech is applied to all high chrome iron impellers. This technology increases wear resistance to particle abrasion.
- 10 Durable Outer Jacket and Strainer**  
Corrugated Outer Jacket and strainer made from 304 stainless steel provide impact resistance to harsh handling and conditions. In pumps 7.5 HP and larger, flat 304 stainless steel outer casing is provided as standard.
- 11 Food Grade Lubricant**  
FLO FAB adopts eco-friendly lubricant to minimize environmental impacts.

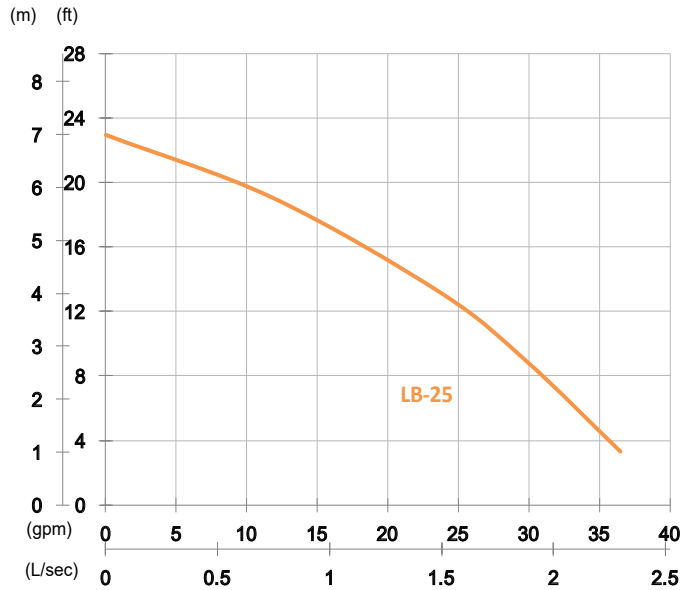

Shaft Speed : 2850 rpm

Outlet : 20mm, 0.75in

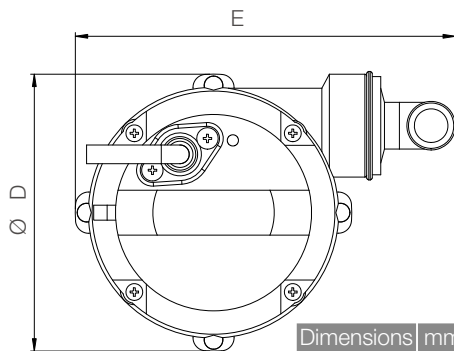

Dimensions	mm	in
A	275	10.8
B	218	8.6
C		
D	8	0.3
E	148	5.8
F	204	8

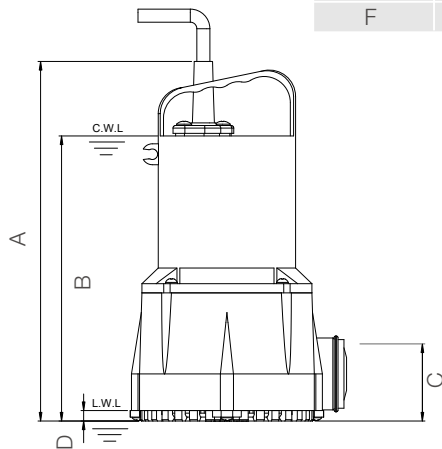

Weight : 4kg / 9 lbs

OUTPUT	HEAD	FLOW
0.25 kW	Rated : 4m, 13ft	Rated : 1.5 L/s, 24 gpm
0.33 HP	Max : 7m, 23ft	Max : 2.2 L/s, 36 gpm

Solid Passage : 6mm, 0.2in

Pump Type	Electric Submersible Pumps	
	1-Phase	
Motor	Type	Induction Motor
	Insulation	Class F
	Protector	Miniature Thermal Protector
	Starter	Capacitor-Run
Lubricant	Food Grade (ISO VG115)	
Impeller Type	Opened	
Shaft Seal	Oil Seal	
Bearings	Shielded ball bearings	
Cable	PVC (CSA Certified) / H05RN-F	
	3m (10ft) or longer upon request.	
Materials	Pump Casing	Synthetic Polymers
	Impeller	Synthetic Polymers
	Motor Frame	Stainless Steel
	Motor Shaft	Stainless Steel
Max. Liquid Temperature	40°C (104°F)	
Max. Submersion Depth	5m (16ft)	
pH Range	pH 5 - pH 8	

✓	
✓	Simplex
✓	Duplex
✓	Triplex

✓	OPTIONAL EQUIPMENT
✓	Additional cable 30 □ 40 □ 50 □ 75 □ Ft.
✓	Slide away coupling
✓	Impeller trims
✓	High Temp winding and seal liquids 190°F / 88°C

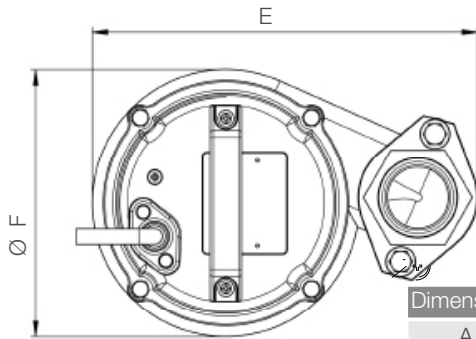
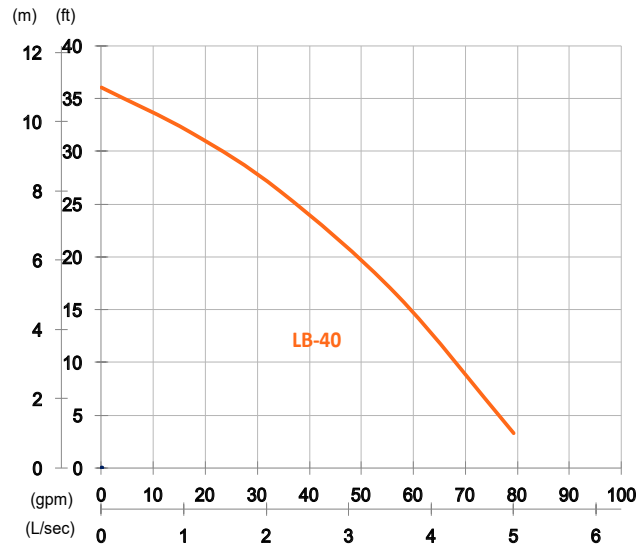

Dimensions	mm	in
A	376	14.8
B	326	12.8
C		
D	90	3.5
E	245	9.6
F	170	6.7

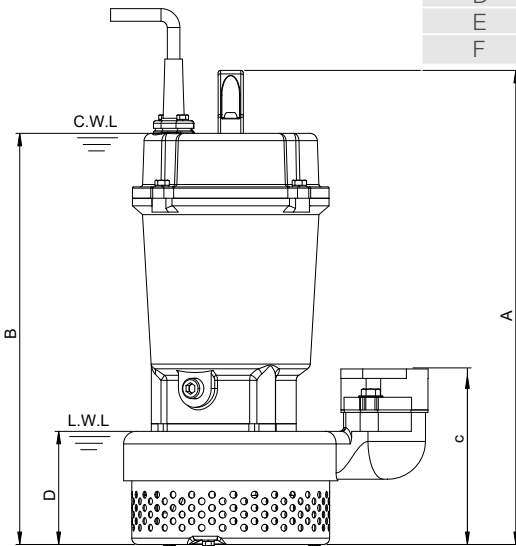

Weight : 16kg / 35 lbs

Shaft Speed : 2850 rpm

Outlet : 50mm, 2in

OUTPUT	HEAD	FLOW
0.4 kW	Rated : 8m, 26ft	Rated : 2.2 L/s, 34 gpm
0.5 HP	Max : 11m, 36ft	Max : 5 L/s, 79 gpm

Solid Passage : 5.5mm, 0.2in

Pump Type		Electric Submersible Pumps
		1-Phase, 3-Phase
Motor	Type	Induction Motor
	Insulation	Class F
	Protector	Circle Thermal Protector
	Starter	1-Phase · Capacitor-Run, 3-Phase · D.O.L.
Lubricant		Food Grade (ISO VG32)
Impeller Type		Semi-Open
Shaft Seal		Double Mechanical Seal
		Silicon Carbide VS Ceramic / Carbon
Bearings		C3 Shielded ball bearings
Cable		PVC (CSA Certified) / H07RN-F
		6m (20ft) or longer upon request.
Materials	Pump Casing	Gray Iron
	Impeller	Gray Iron
	Motor Frame	Gray Iron
	Motor Shaft	Stainless Steel
	Strainer	Stainless Steel
Max. Liquid Temperature		40°C (104°F)
Max. Submersion Depth		20m (66ft)
pH Range		pH 5 - pH 8

<input checked="" type="checkbox"/>	Simplex
<input type="checkbox"/>	Duplex
<input type="checkbox"/>	Triplex

<input checked="" type="checkbox"/>	OPTIONAL EQUIPMENT
<input type="checkbox"/>	Additional cable 30 □ 40 □ 50 □ 75 □ Ft.
<input type="checkbox"/>	Slide away coupling
<input type="checkbox"/>	Impeller trims
<input type="checkbox"/>	High Temp winding and seal liquids 190°F / 88°C

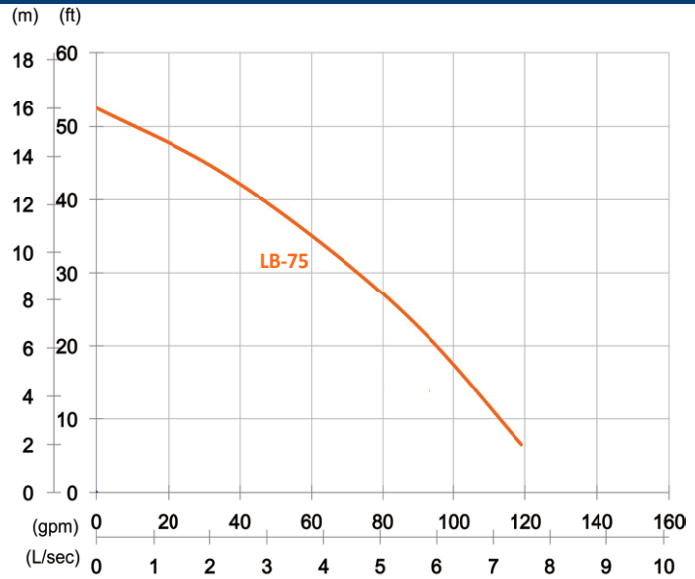

Shaft Speed: 2850 rpm

Outlet : 50mm, 2in

OUTPUT	HEAD	FLOW
0.75 kW	Rated : 10m, 33ft	Rated : 4.2 L/s, 66 gpm
1 HP	Max : 16m, 52ft	Max : 7.5 L/s, 119 gpm

Solid Passage : 5.5mm, 0.2in

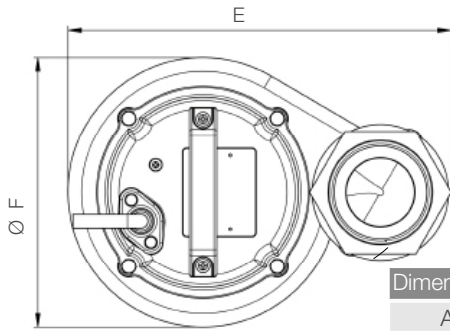

Dimensions	mm	in
A	438	17.2
B	388	15.3
C		
D	96	3.8
E	281	11
F	198	7.8

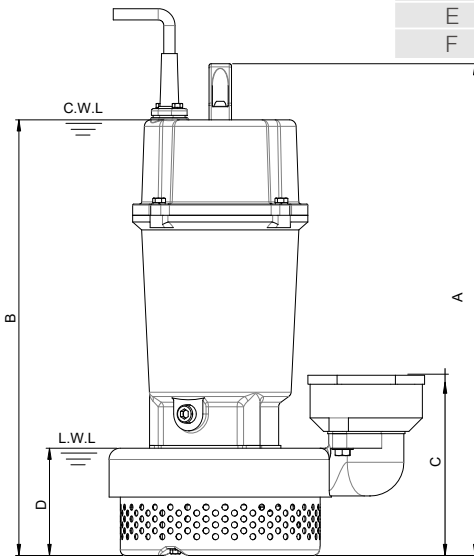

unit : mm

Weight : 21kg / 46 lbs

Pump Type	Electric Submersible Pumps	
	1-Phase, 3-Phase	
Motor	Type	Induction Motor
	Insulation	Class F
	Protector	Circle Thermal Protector
	Starter	1-Phase · Capacitor-Run, 3-Phase · D.O.L.
Lubricant	Food Grade (ISO VG32)	
Impeller Type	Semi-Open	
Shaft Seal	Double Mechanical Seal	
	Silicon Carbide VS Ceramic / Carbon	
Bearings	C3 Shielded ball bearings	
Cable	PVC (CSA Certified) / H07RN-F	
	6m (20ft) or longer upon request.	
Materials	Pump Casing	Gray Iron
	Impeller	Gray Iron
	Motor Frame	Gray Iron
	Motor Shaft	Stainless Steel
	Strainer	Stainless Steel
Max. Liquid Temperature	40°C (104°F)	
Max. Submersion Depth	20m (66ft)	
pH Range	pH 5 - pH 8	

<input checked="" type="checkbox"/>	Simplex
<input type="checkbox"/>	Duplex
<input type="checkbox"/>	Triplex

<input checked="" type="checkbox"/>	OPTIONAL EQUIPMENT
<input type="checkbox"/>	Additional cable 30 □ 40 □ 50 □ 75 □ Ft.
<input type="checkbox"/>	Slide away coupling
<input type="checkbox"/>	Impeller trims
<input type="checkbox"/>	High Temp winding and seal liquids 190°F / 88°C

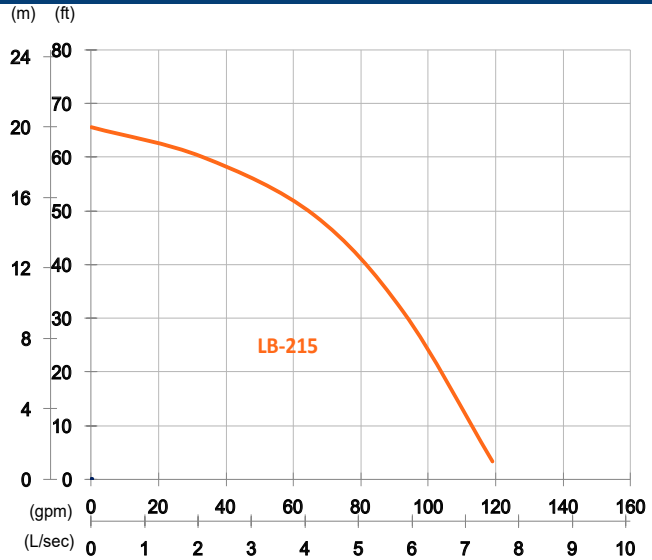

Shaft Speed : 2850 rpm

Outlet : 50mm, 2in

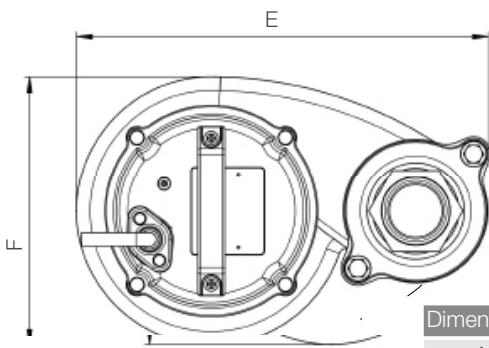

Dimensions	mm	in
A	441	17.4
B	391	15.4
C		
D	97	3.8
E	305	12
F	198	7.8

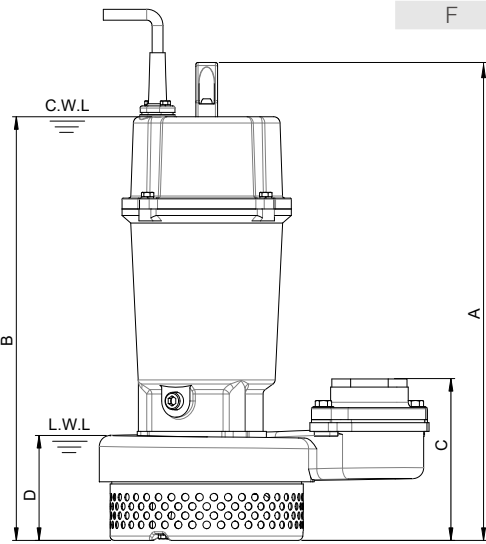

Weight : 23kg / 51 lbs

OUTPUT	HEAD	FLOW
1.5 kW	Rated : 15m, 49ft	Rated : 4.2 L/s, 66 gpm
2 HP	Max : 20m, 66ft	Max : 7.5 L/s, 119 gpm

Solid Passage : 7mm, 0.3in

Pump Type	Electric Submersible Pumps	
	1-Phase, 3-Phase	
Motor	Type	Induction Motor
	Insulation	Class F
	Protector	Circle Thermal Protector
	Starter	1-Phase · Capacitor-Run, 3-Phase · D.O.L.
	Lubricant	Food Grade (ISO VG32)
Impeller Type	Semi-Open	
Shaft Seal	Double Mechanical Seal	
	Silicon Carbide VS Ceramic / Carbon	
Bearings	C3 Shielded ball bearings	
Cable	PVC (CSA Certified) / H07RN-F	
	6m (20ft) or longer upon request.	
Materials	Pump Casing	Gray Iron
	Impeller	Gray Iron
	Motor Frame	Gray Iron
	Motor Shaft	Stainless Steel
	Strainer	Stainless Steel
Max. Liquid Temperature	40°C (104°F)	
Max. Submersion Depth	20m (66ft)	
pH Range	pH 5 - pH 8	

✓	OPTIONAL EQUIPMENT
Simplex	Additional cable 30 □ 40 □ 50 □ 75 □ Ft.
Duplex	Slide away coupling
Triplex	Impeller trims
	High Temp winding and seal liquids 190°F / 88°C

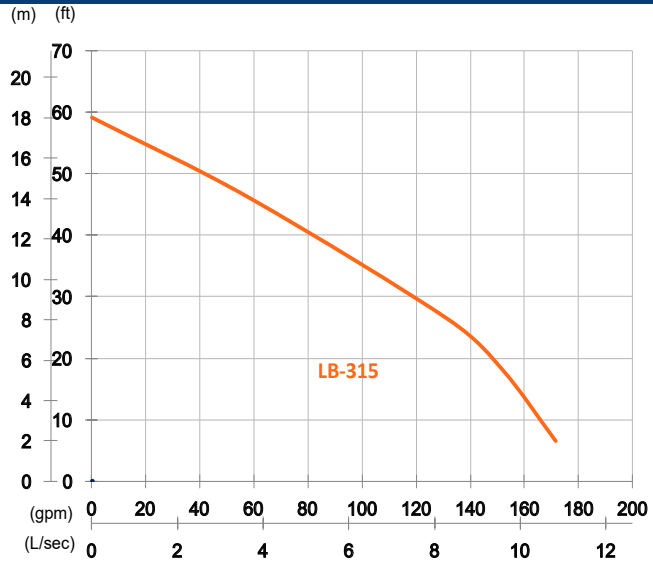

Shaft Speed : 2850 rpm

Outlet : 80mm, 3in

OUTPUT	HEAD	FLOW
1.5 kW	Rated : 8m, 26ft	Rated : 8.3 L/s, 132 gpm
2 HP	Max : 18m, 59ft	Max : 10.8 L/s, 172 gpm

Solid Passage : 7mm, 0.3in

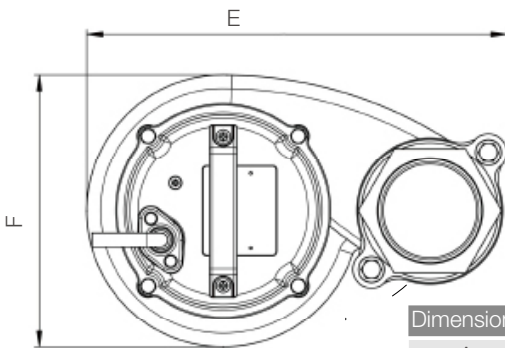

Dimensions	mm	in
A	441	17.4
B	391	15.4
C		
D	97	3.8
E	305	12
F	198	7.8

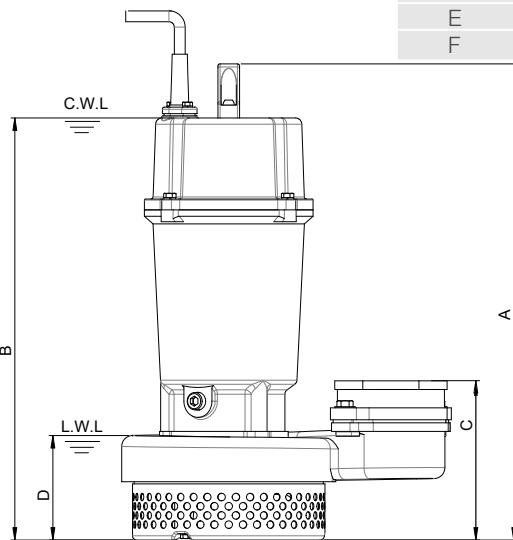

Weight : 23kg / 51 lbs

Pump Type		Electric Submersible Pumps
		1-Phase, 3-Phase
Motor	Type	Induction Motor
	Insulation	Class F
	Protector	Circle Thermal Protector
	Starter	1-Phase · Capacitor-Run, 3-Phase · D.O.L.
Lubricant		Food Grade (ISO VG32)
Impeller Type		Semi-Open
Shaft Seal		Double Mechanical Seal Silicon Carbide VS Ceramic / Carbon
Bearings		C3 Shielded ball bearings
Cable		PVC (CSA Certified) / H07RN-F 6m (20ft) or longer upon request.
Materials	Pump Casing	Gray Iron
	Impeller	Gray Iron
	Motor Frame	Gray Iron
	Motor Shaft	Stainless Steel
	Strainer	Stainless Steel
Max. Liquid Temperature		40°C (104°F)
Max. Submersion Depth		20m (66ft)
pH Range		pH 5 - pH 8

<input checked="" type="checkbox"/>	Simplex
<input type="checkbox"/>	Duplex
<input type="checkbox"/>	Triplex

<input checked="" type="checkbox"/>	OPTIONAL EQUIPMENT
<input type="checkbox"/>	Additional cable 30 □ 40 □ 50 □ 75 □ Ft.
<input type="checkbox"/>	Slide away coupling
<input type="checkbox"/>	Impeller trims
<input type="checkbox"/>	High Temp winding and seal liquids 190°F / 88°C

**LBV-40**

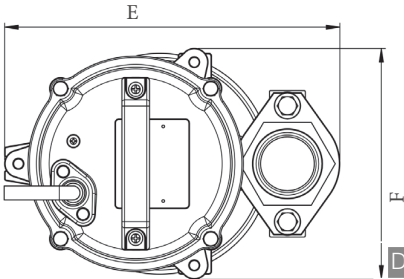

Dimensions	mm	in
A	345	13.6
B	395	15.5
C		
D	89	3.5
E	243	9.6
F	167	6.6

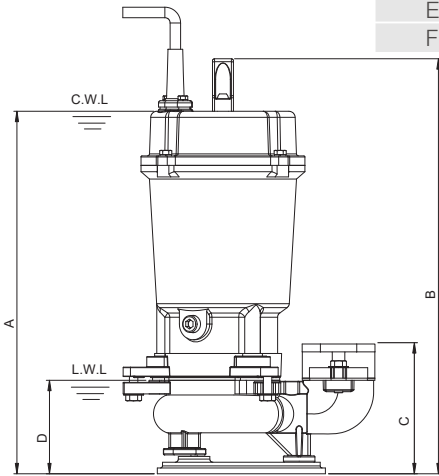

Weight : 14kg / 31 lbs

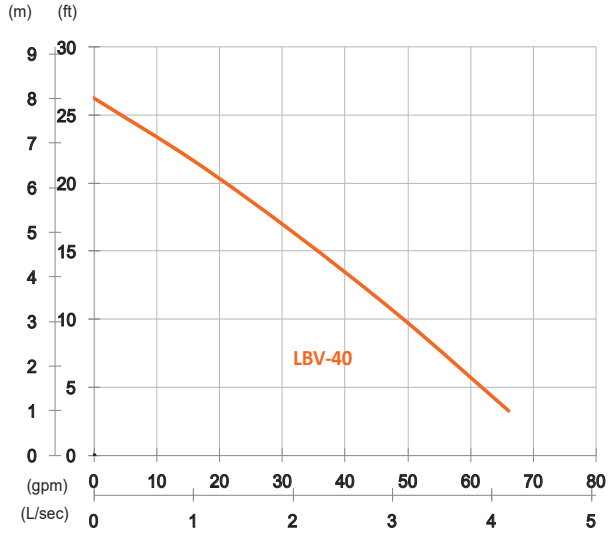

Shaft Speed : 2850 rpm

Outlet : 50mm, 2in

OUTPUT	HEAD	FLOW
0.40 kW	Rated : 5m, 16ft	Rated : 2 L/s, 32 gpm
1/2HP	Max : 8m, 26ft	Max : 4.2 L/s, 66 gpm

Solid Passage : 32 mm, 1.3 in

Pump Type		Electric Submersible Pumps
		1-Phase, 3-Phase
Motor	Type	Induction Motor
	Insulation	Class F
	Protector	Circle Thermal Protector
	Starter	1-Phase · Capacitor-Run, 3-Phase · D.O.L.
Lubricant		Food Grade (ISO VG32)
Impeller Type		Vortex
Shaft Seal		Double Mechanical Seal
		Silicon Carbide VS Ceramic / Carbon
Bearings		C3 Shielded ball bearings
Cable		PVC (CSA Certified) / H07RN-F
		6m (20ft) or longer upon request.
Materials	Pump Casing	Gray Iron
	Impeller	Gray Iron
	Motor Frame	Gray Iron
	Motor Shaft	Stainless Steel
Max. Liquid Temperature		40°C (104°F)
Max. Submersion Depth		20m (66ft)
pH Range		pH 5 - pH 8

✓	
	Simplex
	Duplex
	Triplex

✓	OPTIONAL EQUIPMENT
	Additional cable 30 □ 40 □ 50 □ 75 □ Ft.
	Slide away coupling
	Impeller trims
	High Temp winding and seal liquids 190°F / 88°C

**LBV-75**

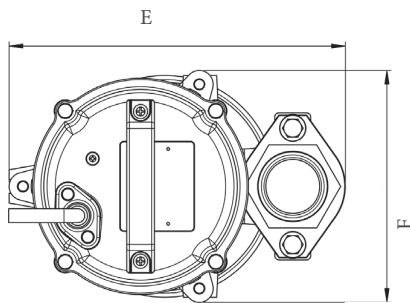
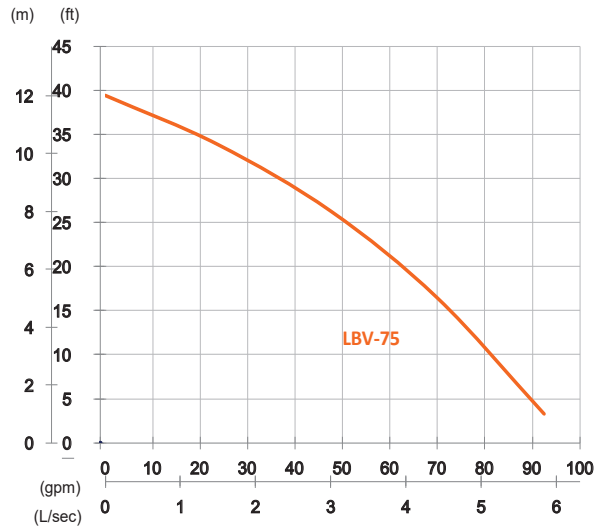

Dimensions	mm	in
A	423	16.7
B	473	18.6
C		
D	107	4.2
E	243	9.6
F	167	6.6

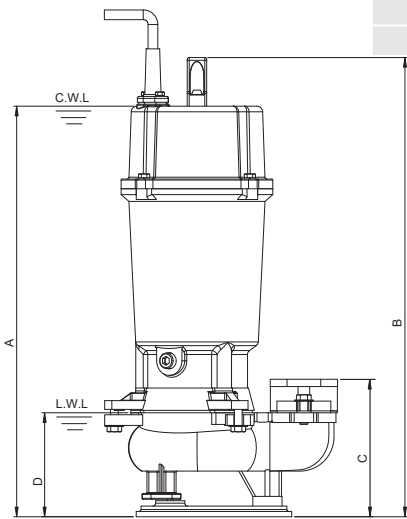

Weight : 20kg / 44 lbs

Shaft Speed : 2850 rpm

Outlet : 50mm, 2in

OUTPUT	HEAD	FLOW
0.75 kW	Rated : 8m, 26ft	Rated : 3 L/s, 48 gpm
1 HP	Max : 12m, 39ft	Max : 5.8 L/s, 92 gpm

Solid Passage : 37mm, 1.5in

Pump Type		Electric Submersible Pumps
		1-Phase, 3-Phase
Motor	Type	Induction Motor
	Insulation	Class F
	Protector	Circle Thermal Protector
	Starter	1-Phase · Capacitor-Run, 3-Phase · D.O.L.
Lubricant		Food Grade (ISO VG32)
Impeller Type		Vortex
Shaft Seal		Double Mechanical Seal
		Silicon Carbide VS Ceramic / Carbon
Bearings		C3 Shielded ball bearings
Cable		PVC (CSA Certified) / H07RN-F
		6m (20ft) or longer upon request.
Materials	Pump Casing	Gray Iron
	Impeller	Gray Iron
	Motor Frame	Gray Iron
	Motor Shaft	Stainless Steel
Max. Liquid Temperature		40°C (104°F)
Max. Submersion Depth		20m (66ft)
pH Range		pH 5 - pH 8

✓	
	Simplex
	Duplex
	Triplex

✓	OPTIONAL EQUIPMENT
	Additional cable 30 □ 40 □ 50 □ 75 □ Ft.
	Slide away coupling
	Impeller trims
	High Temp winding and seal liquids 190°F / 88°C



**LBV-208**

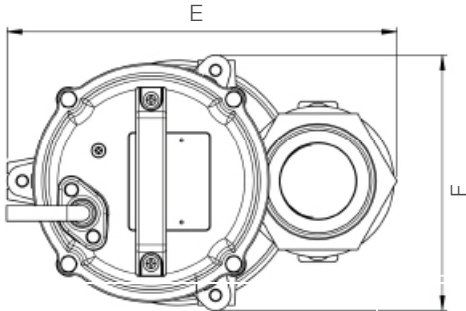

Dimensions	mm	in
A	423	16.7
B	473	18.6
C		
D	107	4.2
E	257	10.1
F	167	6.6

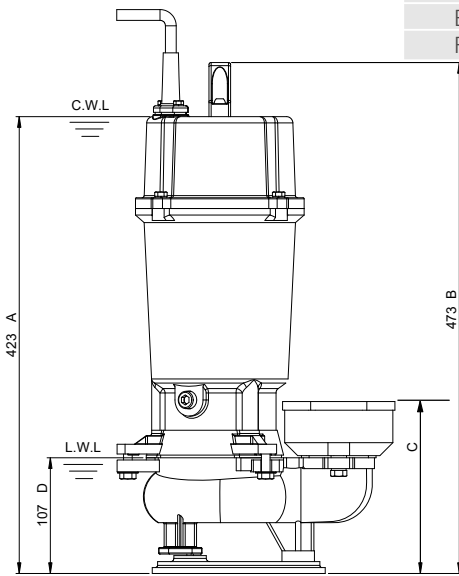

Weight : 20kg / 44 lbs

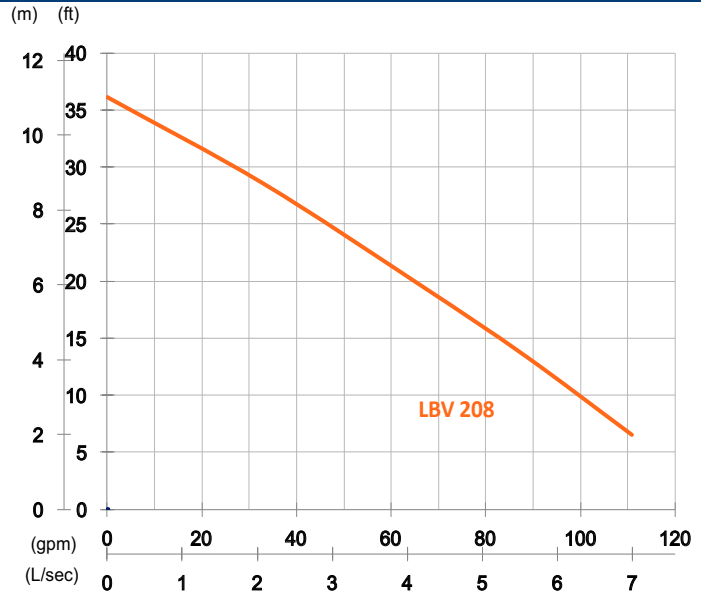

Shaft Speed : 2850 rpm

Outlet : 50mm, 2in

OUTPUT	HEAD	FLOW
0.75 kW	Rated : 6m, 20ft	Rated : 4.2 L/s, 66 gpm
1 HP	Max : 11m, 36ft	Max : 7 L/s, 111 gpm

Solid Passage : 37mm, 1.5in

Pump Type		Electric Submersible Pumps
		1-Phase, 3-Phase
Motor	Type	Induction Motor
	Insulation	Class F
	Protector	Circle Thermal Protector
	Starter	1-Phase · Capacitor-Run, 3-Phase · D.O.L.
Lubricant		Food Grade (ISO VG32)
Impeller Type		Vortex
Shaft Seal		Double Mechanical Seal
		Silicon Carbide VS Ceramic / Carbon
Bearings		C3 Shielded ball bearings
Cable		PVC (CSA Certified) / H07RN-F
		6m (20ft) or longer upon request.
Materials	Pump Casing	Gray Iron
	Impeller	Gray Iron
	Motor Frame	Gray Iron
	Motor Shaft	Stainless Steel
Max. Liquid Temperature		40°C (104°F)
Max. Submersion Depth		20m (66ft)
pH Range		pH 5 - pH 8

<input checked="" type="checkbox"/>	Simplex	<input checked="" type="checkbox"/>	OPTIONAL EQUIPMENT
<input type="checkbox"/>	Duplex	<input type="checkbox"/>	Additional cable 30 □ 40 □ 50 □ 75 □ Ft.
<input type="checkbox"/>	Triplex	<input type="checkbox"/>	Slide away coupling
		<input type="checkbox"/>	Impeller trims
		<input type="checkbox"/>	High Temp winding and seal liquids 190°F / 88°C

**LBV-308**

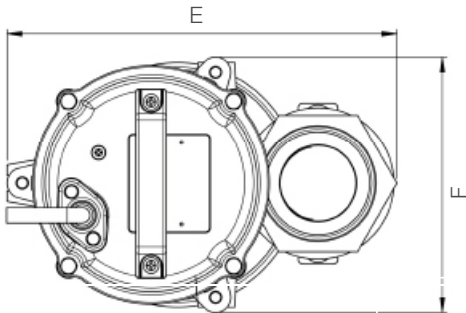

Dimensions	mm	in
A	423	16.7
B	473	18.6
C		
D	107	4.2
E	257	10.1
F	167	6.6

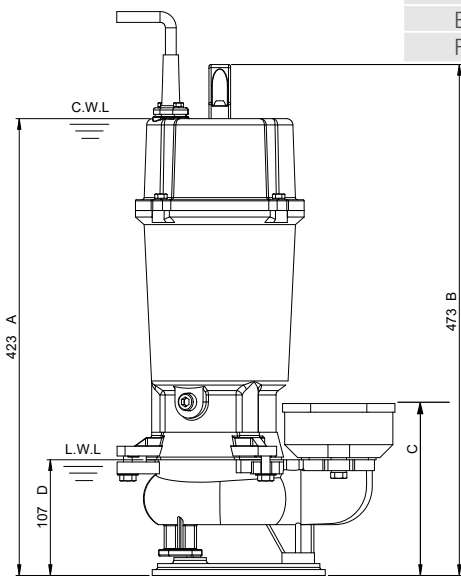

Weight : 20kg / 44 lbs

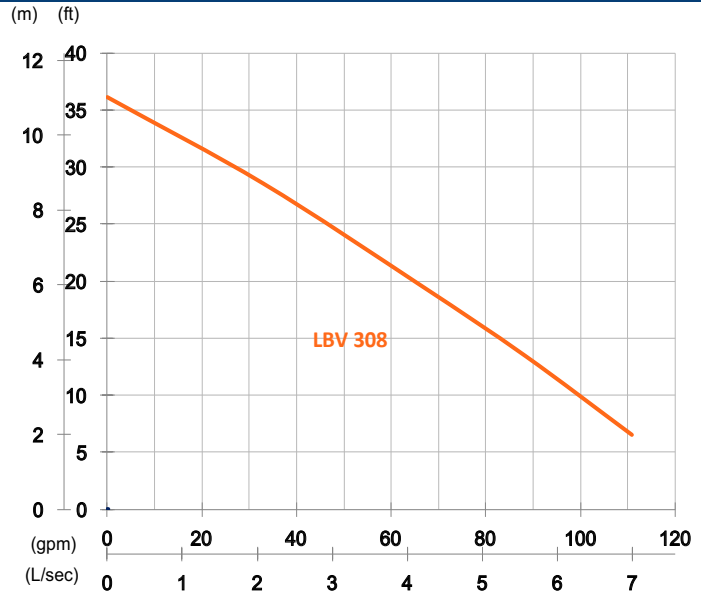

Shaft Speed : 2850 rpm

Outlet : 80mm, 3in

OUTPUT	HEAD	FLOW
0.75 kW	Rated : 6m, 20ft	Rated : 4.2 L/s, 66 gpm
1 HP	Max : 11m, 36ft	Max : 7 L/s, 111 gpm

Solid Passage : 37mm, 1.5in

Pump Type		Electric Submersible Pumps
		1-Phase, 3-Phase
Motor	Type	Induction Motor
	Insulation	Class F
	Protector	Circle Thermal Protector
	Starter	1-Phase · Capacitor-Run, 3-Phase · D.O.L.
Lubricant		Food Grade (ISO VG32)
Impeller Type		Vortex
Shaft Seal		Double Mechanical Seal
		Silicon Carbide VS Ceramic / Carbon
Bearings		C3 Shielded ball bearings
Cable		PVC (CSA Certified) / H07RN-F
		6m (20ft) or longer upon request.
Materials	Pump Casing	Gray Iron
	Impeller	Gray Iron
	Motor Frame	Gray Iron
	Motor Shaft	Stainless Steel
Max. Liquid Temperature		40°C (104°F)
Max. Submersion Depth		20m (66ft)
pH Range		pH 5 - pH 8

✓	OPTIONAL EQUIPMENT
Simplex	Additional cable 30 □ 40 □ 50 □ 75 □ Ft.
Duplex	Slide away coupling
Triplex	Impeller trims
	High Temp winding and seal liquids 190°F / 88°C

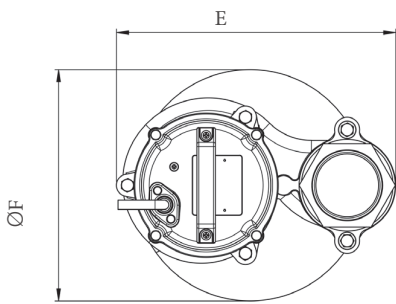

Dimensions	mm	in
A	451	17.8
B	501	19.7
C		
D	146	5.7
E	302	11.9
F	250	9.8

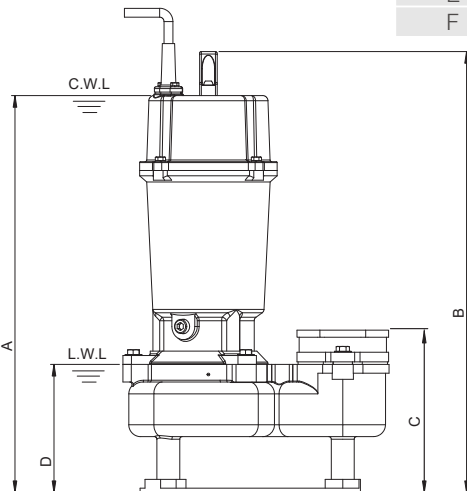

Weight : 24kg / 53 lbs

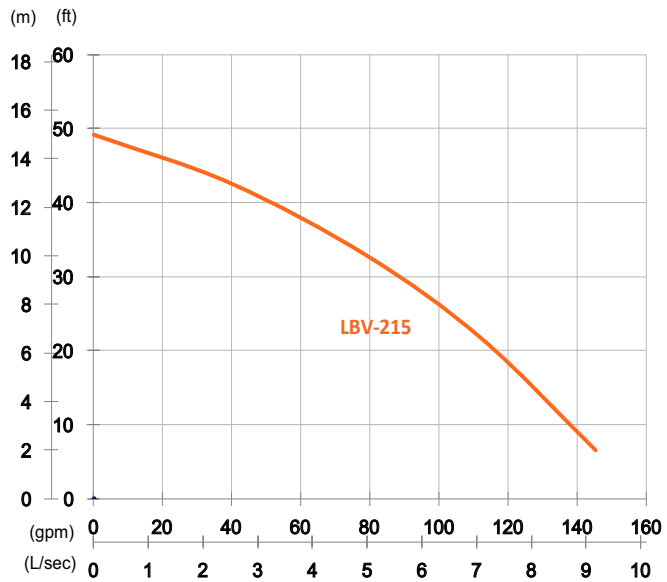

Shaft Speed: 2850 rpm

Outlet : 50mm, 2in

OUTPUT	HEAD	FLOW
1.5 kW	Rated : 10m, 33ft	Rated : 5 L/s, 79 gpm
2 HP	Max : 15m, 49ft	Max : 9.2 L/s, 145 gpm

Solid Passage : 50mm, 2in

Pump Type		Electric Submersible Pumps
		1-Phase, 3-Phase
Motor	Type	Induction Motor
	Insulation	Class F
	Protector	Circle Thermal Protector
	Starter	1-Phase · Capacitor-Run, 3-Phase · D.O.L.
Lubricant		Food Grade (ISO VG32)
Impeller Type		Vortex
Shaft Seal		Double Mechanical Seal Silicon Carbide VS Ceramic / Carbon
Bearings		C3 Shielded ball bearings
Cable		PVC (CSA Certified) / H07RN-F 6m (20ft) or longer upon request.
Materials	Pump Casing	Gray Iron
	Impeller	Gray Iron
	Motor Frame	Gray Iron
	Motor Shaft	Stainless Steel
Max. Liquid Temperature		40°C (104°F)
Max. Submersion Depth		20m (66ft)
pH Range		pH 5 - pH 8

✓	
	Simplex
	Duplex
	Triplex

✓	OPTIONAL EQUIPMENT
	Additional cable 30 □ 40 □ 50 □ 75 □ Ft.
	Slide away coupling
	Impeller trims
	High Temp winding and seal liquids 190°F / 88°C

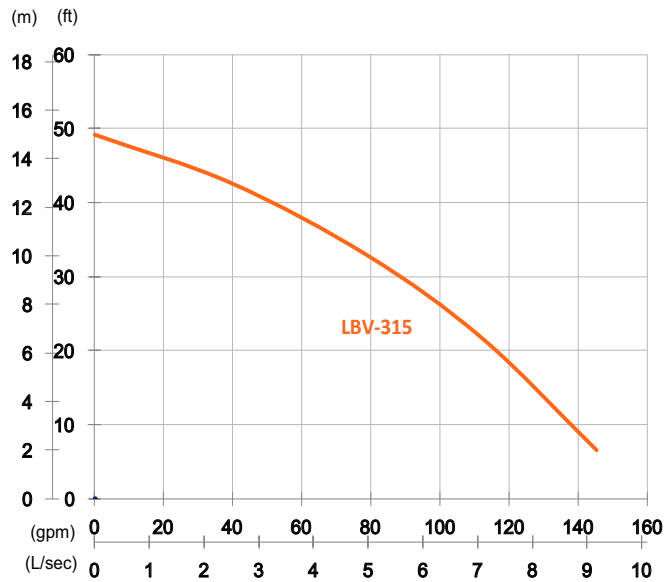

Shaft Speed: 2850 rpm

Outlet : 80mm, 3in

OUTPUT	HEAD	FLOW
1.5 kW	Rated : 10m, 33ft	Rated : 5 L/s, 79 gpm
2 HP	Max : 15m, 49ft	Max : 9.2 L/s, 145 gpm

Solid Passage : 50mm, 2in

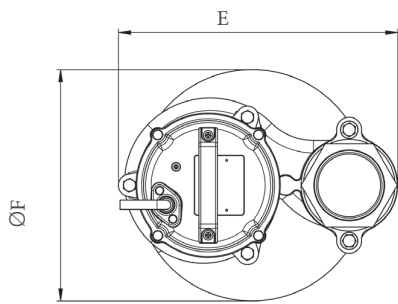

Dimensions	mm	in
A	451	17.8
B	501	19.7
C		
D	146	5.7
E	302	11.9
F	250	9.8

Pump Type		Electric Submersible Pumps
		1-Phase, 3-Phase
Motor	Type	Induction Motor
	Insulation	Class F
	Protector	Circle Thermal Protector
	Starter	1-Phase · Capacitor-Run, 3-Phase · D.O.L.
Lubricant		Food Grade (ISO VG32)
Impeller Type		Vortex
Shaft Seal		Double Mechanical Seal Silicon Carbide VS Ceramic / Carbon
Bearings		C3 Shielded ball bearings
Cable		PVC (CSA Certified) / H07RN-F 6m (20ft) or longer upon request.
Materials	Pump Casing	Gray Iron
	Impeller	Gray Iron
	Motor Frame	Gray Iron
	Motor Shaft	Stainless Steel
Max. Liquid Temperature		40°C (104°F)
Max. Submersion Depth		20m (66ft)
pH Range		pH 5 - pH 8

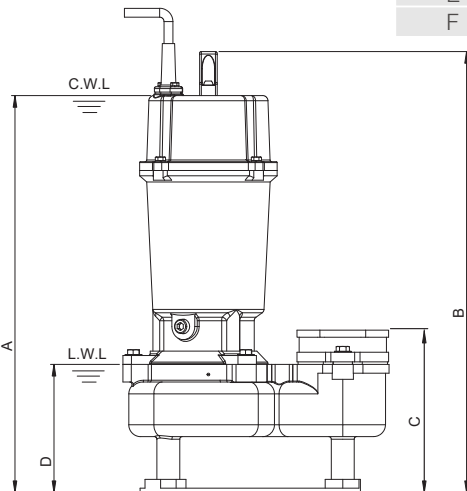

Weight : 24kg / 53 lbs

✓	
	Simplex
	Duplex
	Triplex

✓	OPTIONAL EQUIPMENT
	Additional cable 30 □ 40 □ 50 □ 75 □ Ft.
	Slide away coupling
	Impeller trims
	High Temp winding and seal liquids 190°F / 88°C

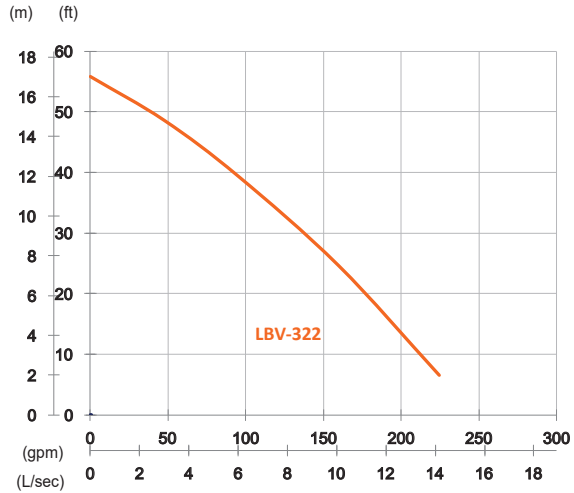

Shaft Speed: 2850 rpm

Outlet : 80mm, 3in

OUTPUT	HEAD	FLOW
2.2 kW	Rated : 12m, 39ft	Rated : 6 L/s, 95 gpm
3 HP	Max : 17m, 56ft	Max : 14.2 L/s, 224 gpm

Solid Passage : 55mm, 2.2in

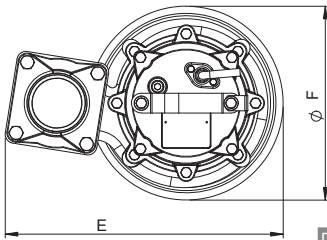

Dimensions	mm	in
A	660	26
B	531	20.9
C		
D	150	5.9
E	366	14.4
F	255	10

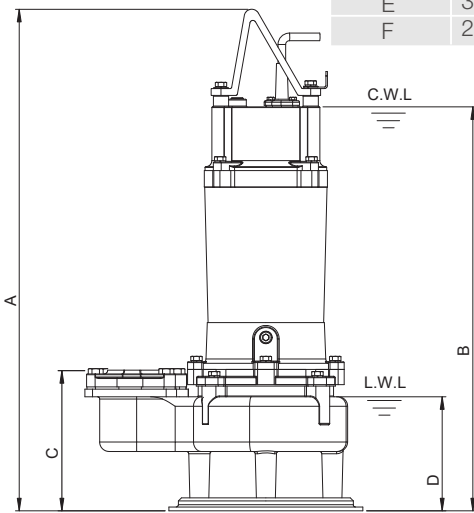

Weight : 40kg / 88 lbs

Pump Type		Electric Submersible Pumps
		3-Phase
Motor	Type	Induction Motor
	Insulation	Class F
	Protector	Circle Thermal Protector
	Starter Method	D.O.L.
Lubricant		Food Grade (ISO VG32)
Impeller Type		Vortex
Shaft Seal		Double Mechanical Seal
		Silicon Carbide VS Ceramic / Carbon
Bearings		C3 Shielded ball bearings
Cable		PVC (CSA Certified) / H07RN-F
		10m (33ft) or longer upon request.
Materials	Pump Casing	Ductile Iron
	Impeller	Gray Iron
	Motor Frame	Gray Iron
	Motor Shaft	Stainless Steel
Max. Liquid Temperature		40°C (104°F)
Max. Submersion Depth		20m (66ft)
pH Range		pH 5 - pH 8

✓	
	Simplex
	Duplex
	Triplex

✓	OPTIONAL EQUIPMENT
	Additional cable 30 □ 40 □ 50 □ 75 □ Ft.
	Slide away coupling
	Impeller trims
	High Temp winding and seal liquids 190°F / 88°C

## LBV-337

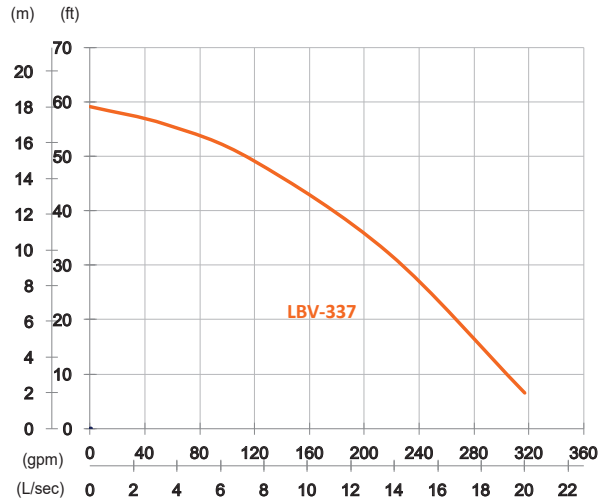

Shaft Speed: 2850 rpm

Outlet : 80mm, 3in

OUTPUT	HEAD	FLOW
3.7 kW	Rated : 15m, 49ft	Rated : 7.5 L/s, 119 gpm
5 HP	Max : 18m, 59ft	Max : 20 L/s, 317 gpm

Solid Passage : 55mm, 2.2in

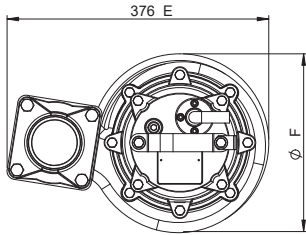

Dimensions	mm	in
A	717	17.8
B	589	28.2
C		
D	159	6.3
E	376	14.8
F	255	10

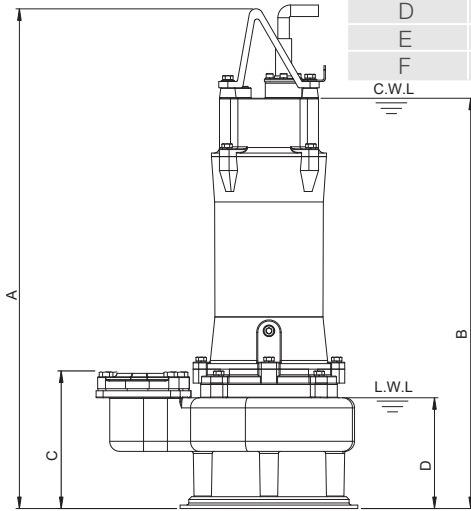

Weight : 49kg / 108 lbs

Pump Type		Electric Submersible Pumps
		3-Phase
Motor	Type	Induction Motor
	Insulation	Class F
	Protector	Circle Thermal Protector
	Starter Method	D.O.L.
Lubricant		Food Grade (ISO VG32)
Impeller Type		Vortex
Shaft Seal		Double Mechanical Seal
		Silicon Carbide VS Ceramic / Carbon
Bearings		C3 Shielded ball bearings
Cable		PVC (CSA Certified) / H07RN-F
		10m (33ft) or longer upon request.
Materials	Pump Casing	Ductile Iron
	Impeller	Ductile Iron
	Motor Frame	Gray Iron
	Motor Shaft	Stainless Steel
Max. Liquid Temperature		40°C (104°F)
Max. Submersion Depth		20m (66ft)
pH Range		pH 5 - pH 8

<input checked="" type="checkbox"/>	
<input type="checkbox"/>	Simplex
<input type="checkbox"/>	Duplex
<input type="checkbox"/>	Triplex

<input checked="" type="checkbox"/>	OPTIONAL EQUIPMENT
<input type="checkbox"/>	Additional cable 30 □ 40 □ 50 □ 75 □ Ft.
<input type="checkbox"/>	Slide away coupling
<input type="checkbox"/>	Impeller trims
<input type="checkbox"/>	High Temp winding and seal liquids 190°F / 88°C

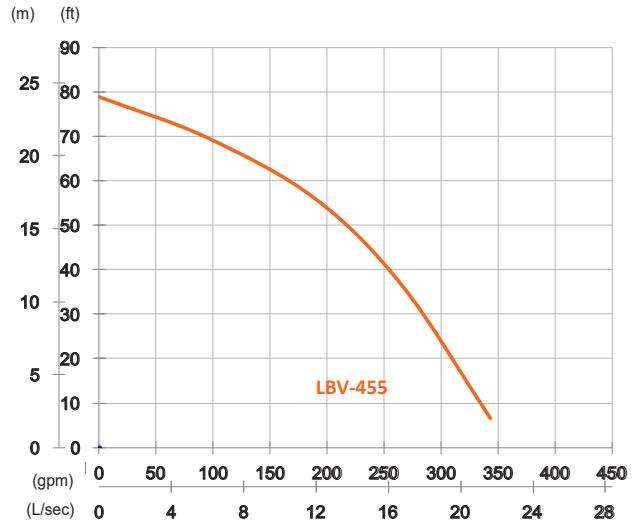

Shaft Speed: 2850 rpm

Outlet : 100mm, 4in

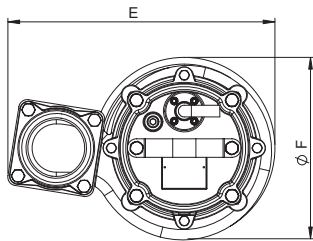

Dimensions	mm	in
A	722	28.4
B	618	24.3
C		
D	159	6.3
E	376	14.8
F	255	10

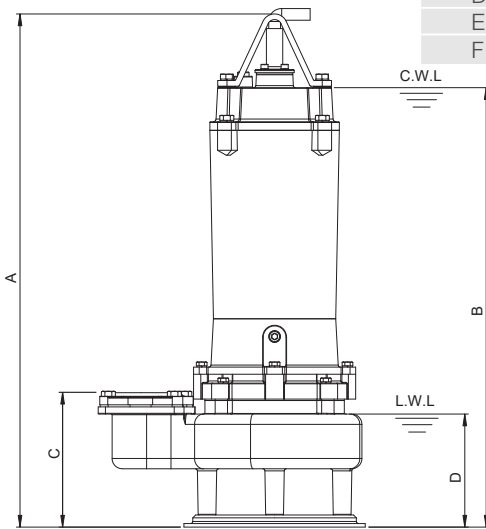

Weight : 60kg / 132 lbs

OUTPUT	HEAD	FLOW
5.5 kW	Rated : 17m, 56ft	Rated : 12 L/s, 190 gpm
7.5 HP	Max : 24m, 79ft	Max : 21.7 L/s, 343 gpm

Solid Passage : 55mm, 2.2in

Pump Type		Electric Submersible Pumps
		3-Phase
Motor	Type	Induction Motor
	Insulation	Class F
	Protector	Circle Thermal Protector
	Starter Method	D.O.L.
Lubricant		Food Grade (ISO VG32)
Impeller Type		Vortex
Shaft Seal		Double Mechanical Seal Silicon Carbide VS Ceramic / Carbon
Bearings		C3 Shielded ball bearings
Cable		PVC (CSA Certified) / H07RN-F 10m (33ft) or longer upon request.
Materials	Pump Casing	Ductile Iron
	Impeller	Gray Iron
	Motor Frame	Gray Iron
	Motor Shaft	Stainless Steel
Max. Liquid Temperature		40°C (104°F)
Max. Submersion Depth		20m (66ft)
pH Range		pH 5 - pH 8

✓	
	Simplex
	Duplex
	Triplex

✓	OPTIONAL EQUIPMENT
	Additional cable 30 □ 40 □ 50 □ 75 □ Ft.
	Slide away coupling
	Impeller trims
	High Temp winding and seal liquids 190°F / 88°C

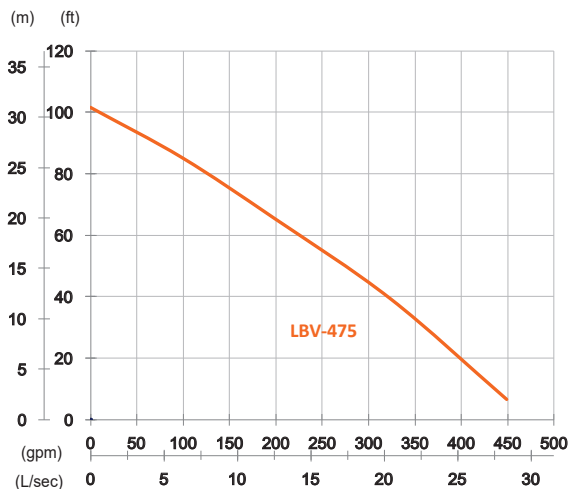

Shaft Speed: 2850 rpm

Outlet : 100mm, 4in

OUTPUT	HEAD	FLOW
7.5 kW	Rated : 20m, 66ft	Rated : 12.5 L/s, 198gpm
10 HP	Max : 31m, 102ft	Max : 28.3 L /s, 449 gpm

Solid Passage : 55mm, 2.2in

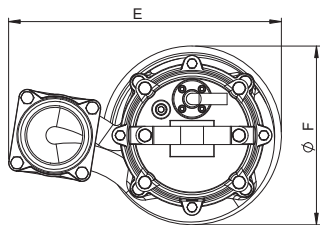

Dimensions	mm	in
A	756	29.8
B	652	25.7
C		
D	192	7.6
E	376	14.8
F	389	15.3

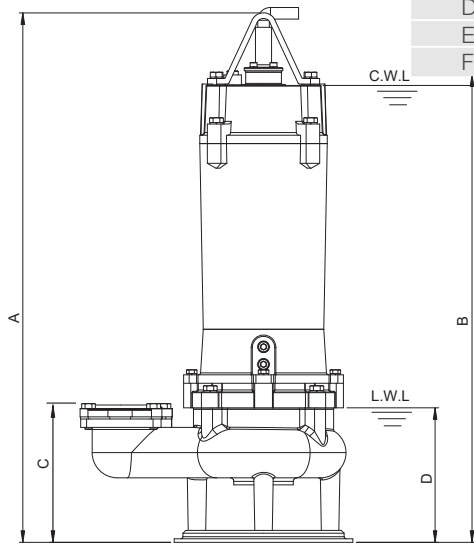

Weight : 67kg / 148 lbs

Pump Type		Electric Submersible Pumps
		3-Phase
Motor	Type	Induction Motor
	Insulation	Class F
	Protector	Circle Thermal Protector
	Starter Method	D.O.L.
Lubricant		Food Grade (ISO VG32)
Impeller Type		Vortex
Shaft Seal		Double Mechanical Seal
		Silicon Carbide VS Ceramic / Carbon
Bearings		C3 Shielded ball bearings
Cable		PVC (CSA Certified) / H07RN-F
		10m (33ft) or longer upon request.
Materials	Pump Casing	Ductile Iron
	Impeller	Gray Iron
	Motor Frame	Gray Iron
	Motor Shaft	Stainless Steel
Max. Liquid Temperature		40°C (104°F)
Max. Submersion Depth		20m (66ft)
pH Range		pH 5 - pH 8

✓	
	Simplex
	Duplex
	Triplex

✓	OPTIONAL EQUIPMENT
	Additional cable 30 □ 40 □ 50 □ 75 □ Ft.
	Slide away coupling
	Impeller trims
	High Temp winding and seal liquids 190°F / 88°C



**LBVSS-75**

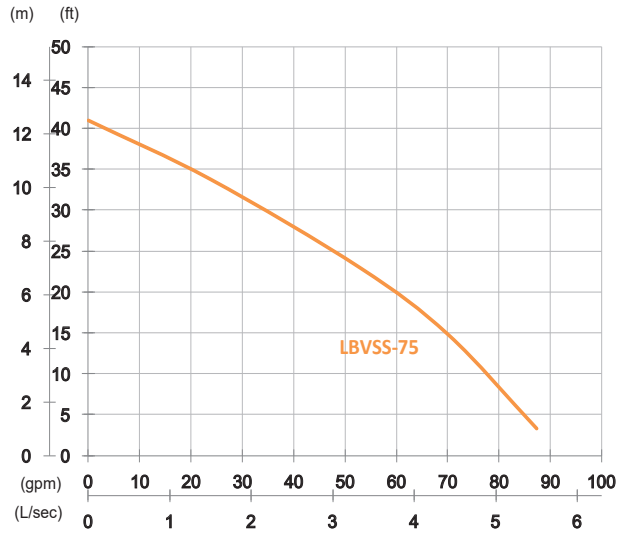

Shaft Speed: 2850 rpm

Outlet : 50mm, 2in

OUTPUT	HEAD	FLOW
0.75 kW	Rated : 7m, 23ft	Rated : 3.3 L/s, 53 gpm
1 HP	Max : 12.5m, 41ft	Max : 5.5 L/s, 87 gpm

Solid Passage : 40mm, 1.6 in

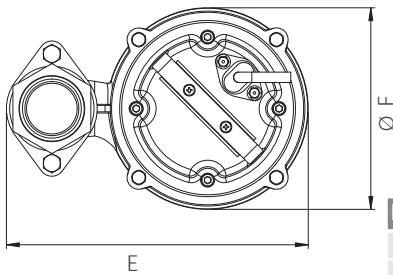

Dimensions	mm	in
A	445	17.5
B	392	15.4
C		
D	108	4.3
E	233	9.2
F	155	6.1

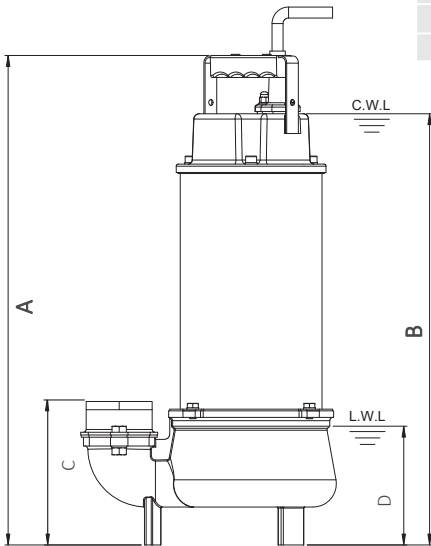

Weight : 12kg / 26 lbs

Pump Type	Electric Submersible Pumps	
	1-Phase, 3-Phase	
Motor	Type	Induction Motor
	Insulation	Class F
	Protector	Circle Thermal Protector
	Starter	1-Phase · Capacitor-Run, 3-Phase · D.O.L.
Lubricant	Food Grade (ISO VG32)	
Impeller Type	Vortex	
Shaft Seal	Double Mechanical Seal	
	Silicon Carbide VS Ceramic / Carbon	
Bearings	C3 Shielded ball bearings	
Cable	PVC (CSA Certified) / H07RN-F	
	6m (20ft) or longer upon request.	
Materials	Pump Casing	Stainless Steel
	Impeller	Stainless Steel
	Motor Frame	Stainless Steel
	Motor Shaft	Stainless Steel
Max. Liquid Temperature	40°C (104°F)	
Max. Submersion Depth	20m (66ft)	
pH Range	pH 5 - pH 8	

✓	
	Simplex
	Duplex
	Triplex

✓	OPTIONAL EQUIPMENT
	Additional cable 30 □ 40 □ 50 □ 75 □ Ft.
	Slide away coupling
	Impeller trims
	High Temp winding and seal liquids 190°F / 88°C

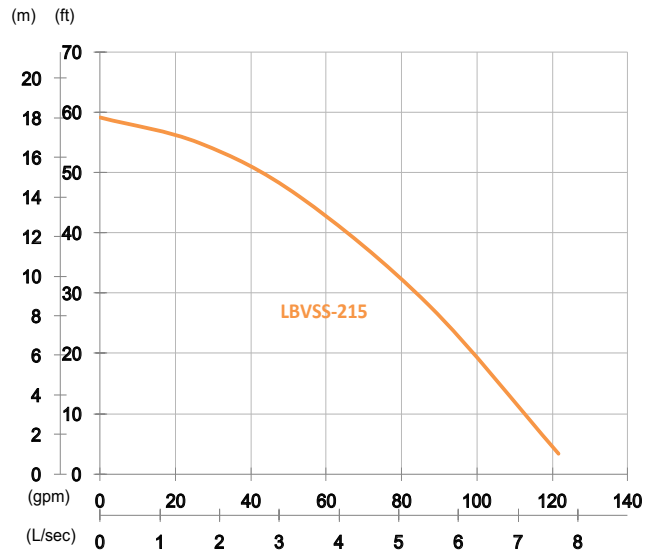

Shaft Speed : 2850 rpm

Outlet : 50mm, 2in

OUTPUT	HEAD	FLOW
1.5 kW	Rated : 14m, 46ft	Rated : 3.3 L/s, 53 gpm
2 HP	Max : 18m, 59ft	Max : 7.7 L/s, 121 gpm

Solid Passage : 37 mm, 1.5 in

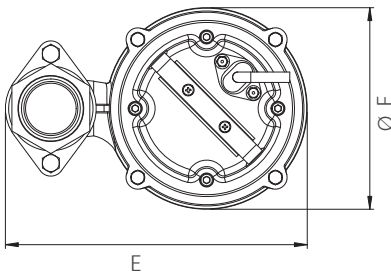

Dimensions	mm	in
A	445	17.5
B	392	15.4
C		
D	108	4.3
E	233	9.2
F	155	6.1

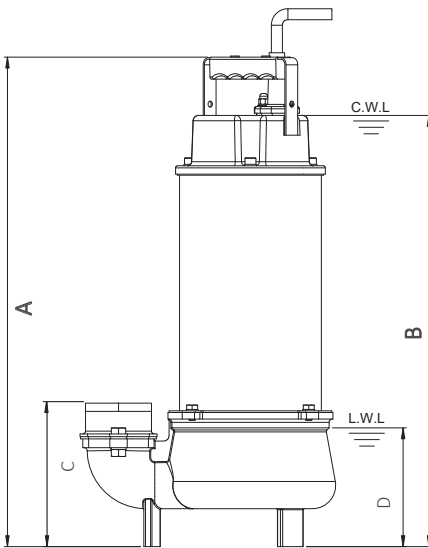

Weight : 15kg / 33 lbs

Pump Type		Electric Submersible Pumps
		1-Phase, 3-Phase
Motor	Type	Induction Motor
	Insulation	Class F
	Protector	Circle Thermal Protector
	Starter	1-Phase · Capacitor-Run, 3-Phase · D.O.L.
Lubricant		Food Grade (ISO VG32)
Impeller Type		Vortex
Shaft Seal		Double Mechanical Seal
		Silicon Carbide VS Ceramic / Carbon
Bearings		C3 Shielded ball bearings
Cable		PVC (OSA Certified) / H07RN-F
		6m (20ft) or longer upon request.
Materials	Pump Casing	Stainless Steel
	Impeller	Stainless Steel
	Motor Frame	Stainless Steel
	Motor Shaft	Stainless Steel
Max. Liquid Temperature		40°C (104°F)
Max. Submersion Depth		20m (66ft)
pH Range		pH 5 - pH 8

✓	
	Simplex
	Duplex
	Triplex

✓	OPTIONAL EQUIPMENT
	Additional cable 30 □ 40 □ 50 □ 75 □ Ft.
	Slide away coupling
	Impeller trims
	High Temp winding and seal liquids 190°F / 88°C



# SERIES FBV Vortex Pump

SUBMITTAL DATA

50HZ

FBV-322

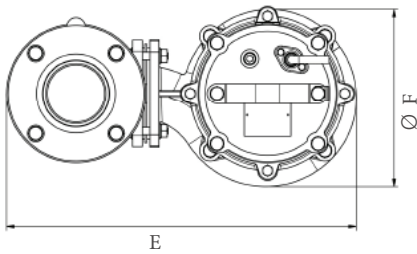
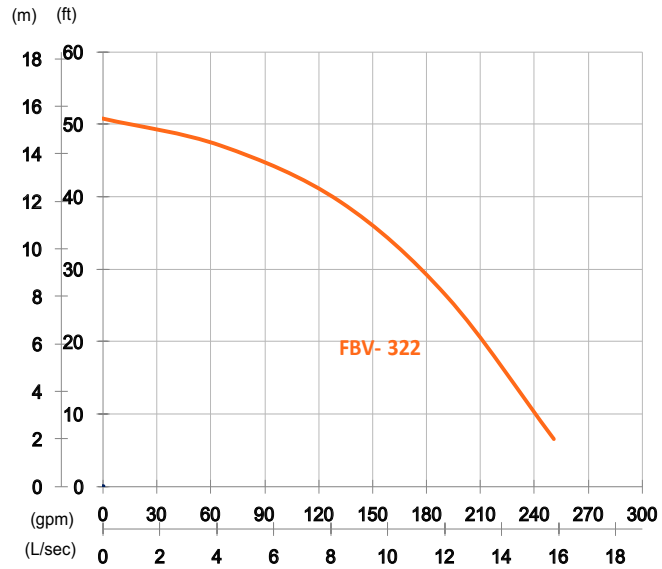

Shaft Speed : 2850 rpm

Outlet : 80mm, 3in

OUTPUT	HEAD	FLOW
2.2 kW	Rated : 12m, 39ft	Rated : 8.3 L/s, 132 gpm
3 HP	Max : 15.5m, 51ft	Max : 15.8 L/s, 251 gpm

Solid Passage : 47 mm, 1.9 in

Dimensions	mm	in
A	645	25.4
B	542	21.3
C	244	9.6
D	155	6.1
E	464	18.3
F	235	9.3

Pump Type		Electric Submersible Pumps
		3-Phase
Motor	Type	Induction Motor
	Insulation	Class F
	Protector	Circle Thermal Protector
	Starter	D.O.L.
Lubricant		Food Grade (ISO VG32)
Impeller Type		Vortex
Shaft Seal		Double Mechanical Seal Silicon Carbide VS Ceramic / Carbon
Bearings		C3 Shielded ball bearings
Cable		PVC (CSA Certified) / H07RN-F 10m (33ft) or longer upon request.
Materials	Pump Casing	Gray Iron
	Impeller	Gray Iron
	Motor Frame	Gray Iron
	Motor Shaft	Stainless Steel
Max. Liquid Temperature		40°C (104°F)
Max. Submersion Depth		20m (66ft)
pH Range		pH 5 - pH 8

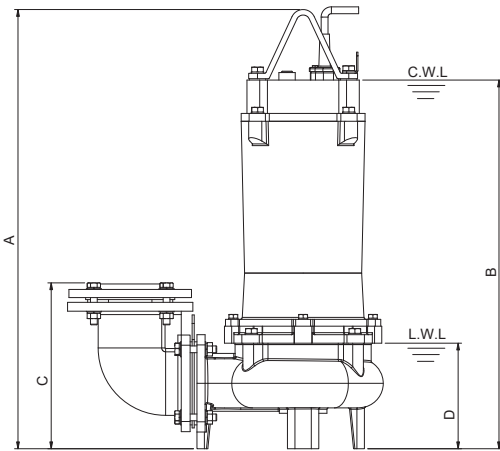

Weight : 60kg / 132 lbs

✓	OPTIONAL EQUIPMENT
Simplex	Additional cable 30 □ 40 □ 50 □ 75 □ Ft.
Duplex	Slide away coupling
Triplex	Impeller trims
	High Temp winding and seal liquids 190°F / 88°C





# SERIES FBV Vortex Pump

**SUBMITTAL DATA**

**50HZ**

**FBV-337**

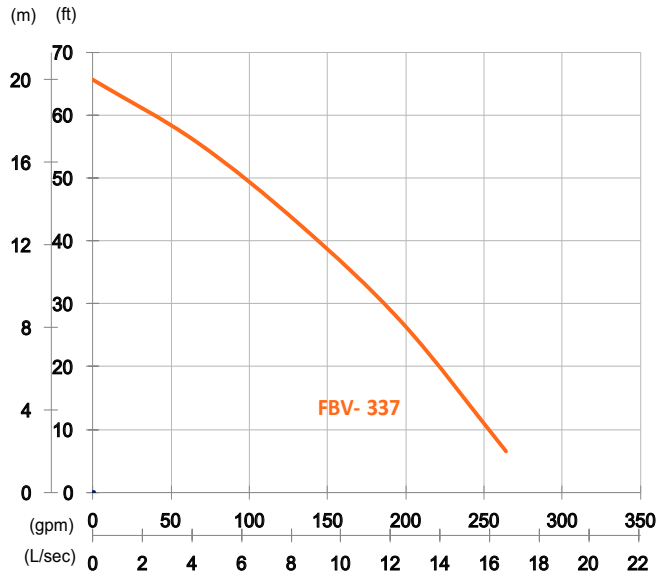

Shaft Speed : 2850 rpm

Outlet : 80mm, 3in

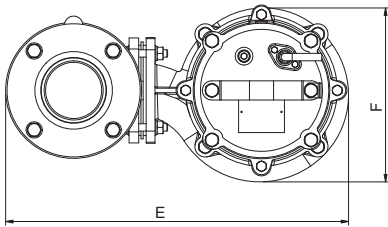

OUTPUT	HEAD	FLOW
3.7 kW	Rated : 13m, 43ft	Rated : 8.3 L/s, 132 gpm
5 HP	Max : 20m, 66ft	Max : 16.7 L/s, 264 gpm

Solid Passage : 52 mm, 2 in

Dimensions	mm	in
A	645	25.4
B	542	21.3
C	244	9.6
D	155	6.1
E	464	18.3
F	235	9.3

Pump Type		Electric Submersible Pumps
		3-Phase
Motor	Type	Induction Motor
	Insulation	Class F
	Protector	Circle Thermal Protector
	Starter	D.O.L.
Lubricant		Food Grade (ISO VG32)
Impeller Type		Vortex
Shaft Seal		Double Mechanical Seal Silicon Carbide VS Ceramic / Carbon
Bearings		C3 Shielded ball bearings
Cable		PVC (CSA Certified) / H07RN-F 10m (33ft) or longer upon request.
Materials	Pump Casing	Gray Iron
	Impeller	Gray Iron
	Motor Frame	Gray Iron
	Motor Shaft	Stainless Steel
Max. Liquid Temperature		40°C (104°F)
Max. Submersion Depth		20m (66ft)
pH Range		pH 5 - pH 8

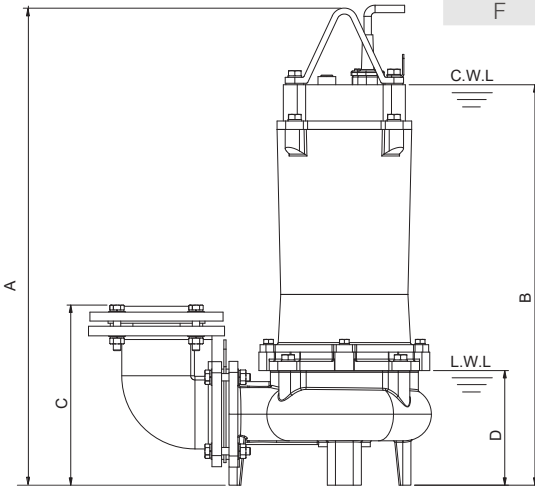

Weight : 64kg / 141 lbs

✓	
	Simplex
	Duplex
	Triplex

✓	OPTIONAL EQUIPMENT
	Additional cable 30 □ 40 □ 50 □ 75 □ Ft.
	Slide away coupling
	Impeller trims
	High Temp winding and seal liquids 190°F / 88°C



**FBV-437**

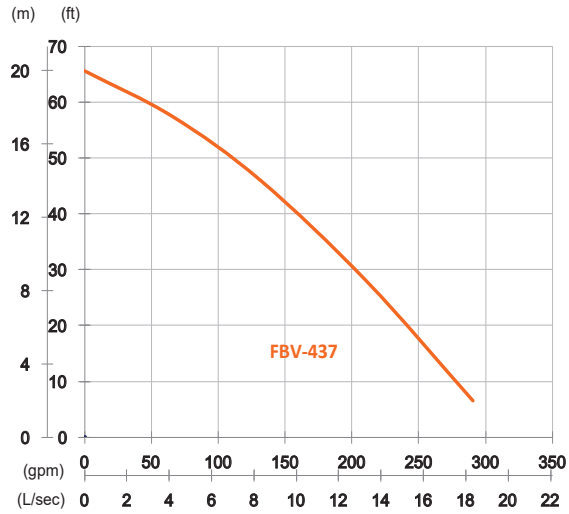

Shaft Speed : 2850 rpm

Outlet : 100mm, 4in

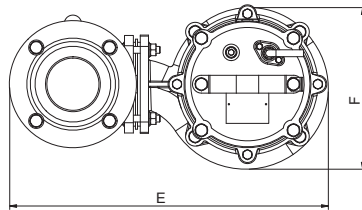

Dimensions	mm	in
A	643	25.3
B	540	21.3
C	253	10
D	153	6
E	464	18.3
F	235	9.3

OUTPUT	HEAD	FLOW
3.7 kW	Rated : 14m, 46ft	Rated : 8.3 L/s, 132 gpm
5 HP	Max : 20m, 66ft	Max : 18.3 L/s, 291 gpm

Solid Passage : 50mm, 2in

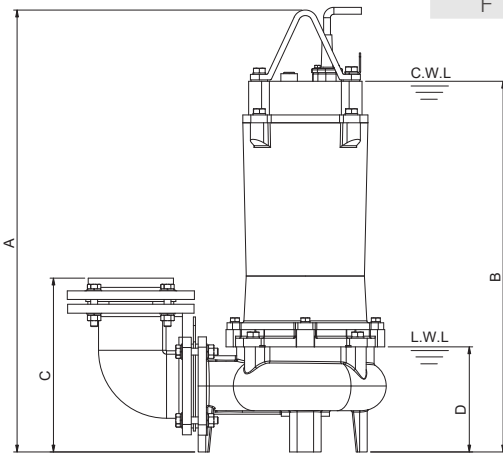

Weight : 64kg / 141 lbs

Pump Type		Electric Submersible Pumps
		3-Phase
Motor	Type	Induction Motor
	Insulation	Class F
	Protector	Circle Thermal Protector
	Starter	D.O.L.
Lubricant		Food Grade (ISO VG32)
Impeller Type		Vortex
Shaft Seal		Double Mechanical Seal
		Silicon Carbide VS Ceramic / Carbon
Bearings		C3 Shielded ball bearings
Cable		PVC (CSA Certified) / H07RN-F
		10m (33ft) or longer upon request.
Materials	Pump Casing	Gray Iron
	Impeller	Gray Iron
	Motor Frame	Gray Iron
	Motor Shaft	Stainless Steel
Max. Liquid Temperature		40°C (104°F)
Max. Submersion Depth		20m (66ft)
pH Range		pH 5 - pH 8

✓	
	Simplex
	Duplex
	Triplex

✓	OPTIONAL EQUIPMENT
	Additional cable 30 □ 40 □ 50 □ 75 □ Ft.
	Slide away coupling
	Impeller trims
	High Temp winding and seal liquids 190°F / 88°C



# SERIES FBV Vortex Pump

SUBMITTAL DATA

50HZ

FBV-455

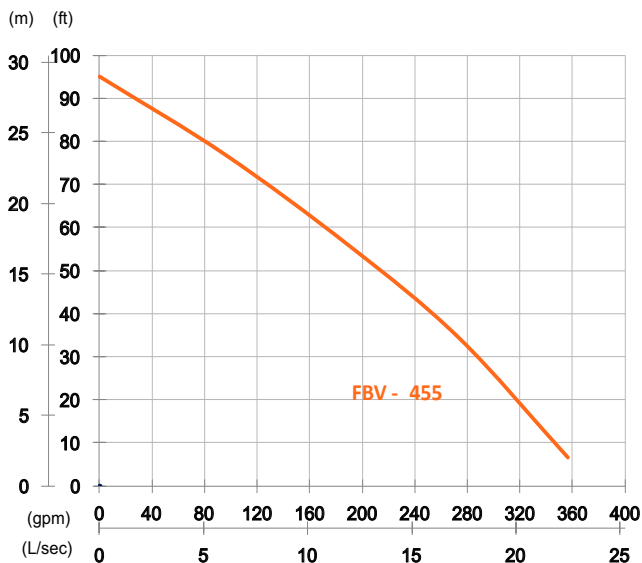

Shaft Speed : 2850 rpm

Outlet : 100mm, 4in

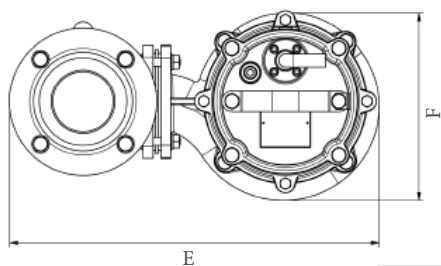

Dimensions	mm	in
A	697	27.4
B	593	23.3
C	253	10
D	155	6.1
E	464	18.3
F	235	9.3

OUTPUT	HEAD	FLOW
5.5 kW	Rated : 17m, 56ft	Rated : 12 L/s, 190 gpm
7.5 HP	Max : 29m, 95ft	Max : 22.5 L/s, 356 gpm

Solid Passage : 50 mm, 2 in

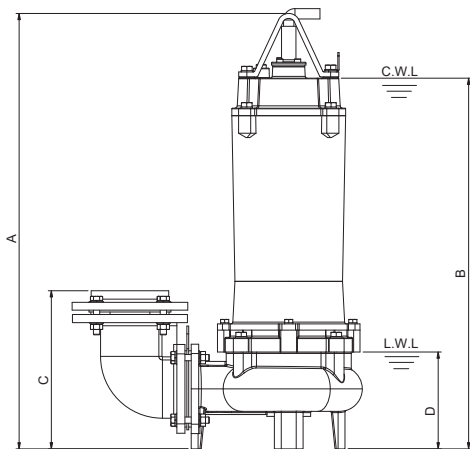

Weight : 73kg / 161 lbs

Pump Type		Electric Submersible Pumps
		3-Phase
Motor	Type	Induction Motor
	Insulation	Class F
	Protector	Circle Thermal Protector
	Starter	D.O.L.
Lubricant		Food Grade (ISO VG32)
Impeller Type		Vortex
Shaft Seal		Double Mechanical Seal
		Silicon Carbide VS Ceramic / Carbon
Bearings		C3 Shielded ball bearings
Cable		PVC (CSA Certified) / H07RN-F
		10m (33ft) or longer upon request.
Materials	Pump Casing	Gray Iron
	Impeller	Gray Iron
	Motor Frame	Gray Iron
	Motor Shaft	Stainless Steel
Max. Liquid Temperature		40°C (104°F)
Max. Submersion Depth		20m (66ft)
pH Range		pH 5 - pH 8

✓	
	Simplex
	Duplex
	Triplex

✓	OPTIONAL EQUIPMENT
	Additional cable 30 □ 40 □ 50 □ 75 □ Ft.
	Slide away coupling
	Impeller trims
	High Temp winding and seal liquids 190°F / 88°C

FloFab is certified :   



# SERIES FBV Vortex Pump

SUBMITTAL DATA

50HZ

## FBV-475

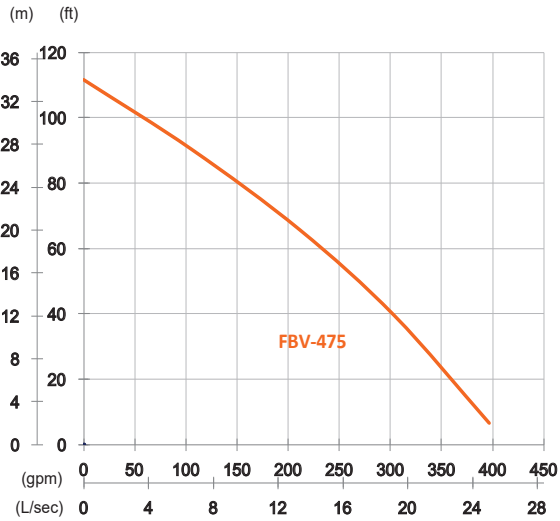
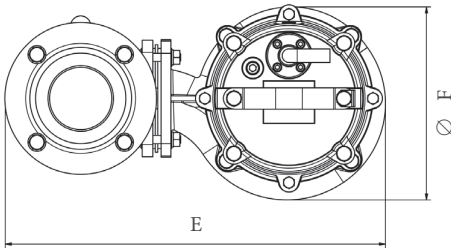

Shaft Speed : 2850 rpm

Outlet : 100mm, 4in

OUTPUT	HEAD	FLOW
7.5 kW	Rated : 20m, 66ft	Rated : 13.3 L/s, 211 gpm
10 HP	Max : 34m, 112ft	Max : 25 L/s, 396 gpm

Solid Passage : 50 mm, 2 in

Dimensions	mm	in
A	719	28.3
B	615	24.2
C	253	10
D	155	6.1
E	464	18.3
F	235	9.3

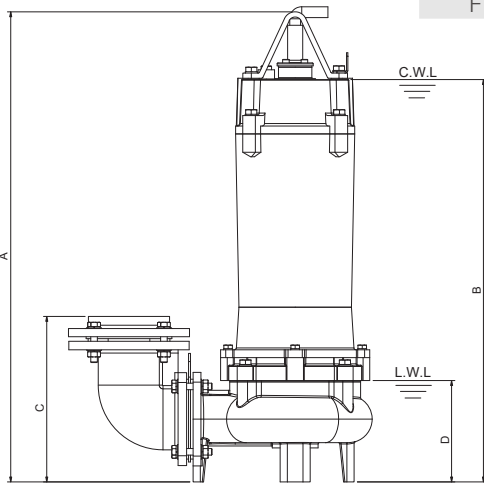

Weight : 75kg / 165 lbs

Pump Type		Electric Submersible Pumps
		3-Phase
Motor	Type	Induction Motor
	Insulation	Class F
	Protector	Circle Thermal Protector
	Starter	D.O.L.
Lubricant		Food Grade (ISO VG32)
Impeller Type		Vortex
Shaft Seal		Double Mechanical Seal
		Silicon Carbide VS Ceramic / Carbon
Bearings		C3 Shielded ball bearings
Cable		PVC (CSA Certified) / H07RN-F
		10m (33ft) or longer upon request.
Materials	Pump Casing	Gray Iron
	Impeller	Gray Iron
	Motor Frame	Gray Iron
	Motor Shaft	Stainless Steel
Max. Liquid Temperature		40°C (104°F)
Max. Submersion Depth		20m (66ft)
pH Range		pH 5 - pH 8

<input checked="" type="checkbox"/>	Simplex
<input type="checkbox"/>	Duplex
<input type="checkbox"/>	Triplex

<input checked="" type="checkbox"/>	OPTIONAL EQUIPMENT
<input type="checkbox"/>	Additional cable 30 □ 40 □ 50 □ 75 □ Ft.
<input type="checkbox"/>	Slide away coupling
<input type="checkbox"/>	Impeller trims
<input type="checkbox"/>	High Temp winding and seal liquids 190°F / 88°C

FloFab is certified :   

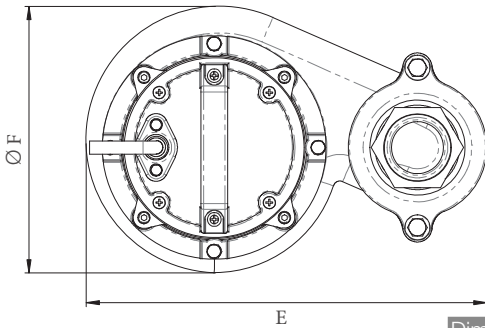
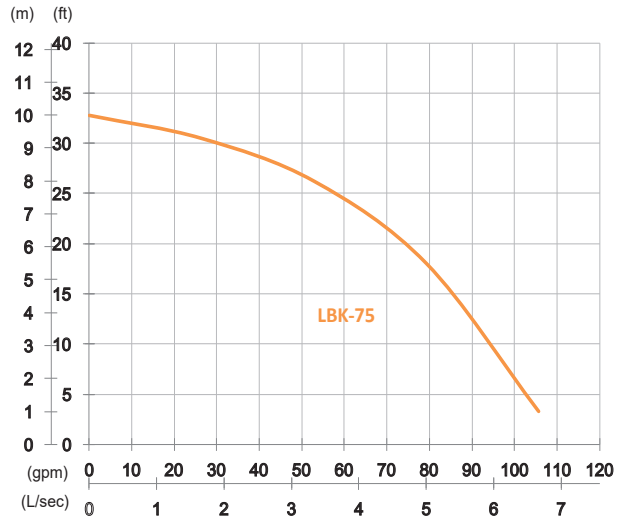

Dimensions	mm	in
A	434	17.1
B	372	14.6
C		
D	104	4.1
E	301	11.9
F	200	7.9

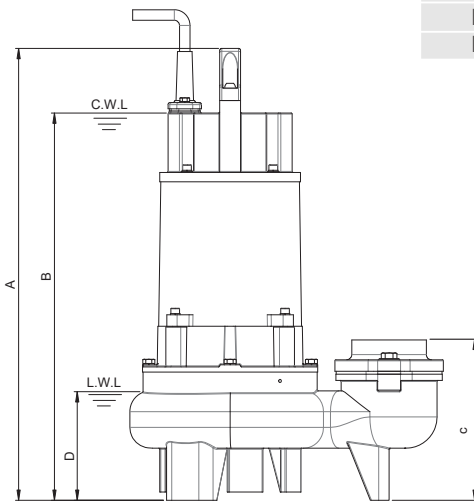

Weight : 22kg / 49 lbs

Shaft Speed : 2850 rpm

Outlet : 50mm, 2in

OUTPUT	HEAD	FLOW
0.75 kW	Rated : 8m, 26ft	Rated : 3.3 L/s, 53 gpm
1 HP	Max : 10m, 33ft	Max : 6.7 L/s, 106 gpm

Solid Passage : 25 mm, 1in

Pump Type		Electric Submersible Pumps
		1-Phase, 3-Phase
Motor	Type	Induction Motor
	Insulation	Class F
	Protector	Circle Thermal Protector
	Starter	1-Phase · Capacitor-Run, 3-Phase · D.O.L.
Lubricant		Food Grade (ISO VG32)
Impeller Type		Semi-Open Channel
Shaft Seal		Double Mechanical Seal
		Silicon Carbide VS Ceramic / Carbon
Bearings		C3 Shielded ball bearings
Cable		PVC (CSA Certified) / H07RN-F
		6m (20ft) or longer upon request.
Materials	Pump Casing	Gray Iron
	Impeller	Gray Iron
	Motor Frame	Gray Iron
	Motor Shaft	Stainless Steel
Max. Liquid Temperature		40°C (104°F)
Max. Submersion Depth		20m (66ft)
pH Range		pH 5 - pH 8

✓	
	Simplex
	Duplex
	Triplex

✓	OPTIONAL EQUIPMENT
	Additional cable 30 □ 40 □ 50 □ 75 □ Ft.
	Slide away coupling
	Impeller trims
	High Temp winding and seal liquids 190°F / 88°C





# SERIES LBK Non-clog Pump

SUBMITTAL DATA

50HZ

LBK-215

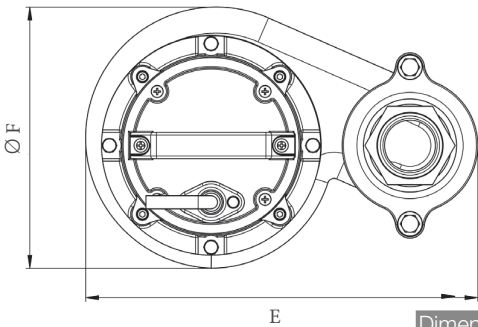
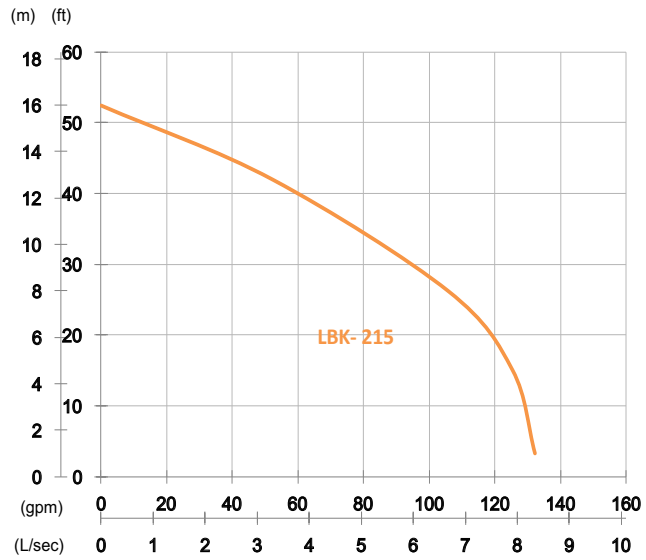

Dimensions	mm	in
A	463	18.2
B	401	15.8
C		
D	104	4.1
E	301	11.9
F	200	7.9

Shaft Speed : 2850 rpm

Outlet : 50mm, 2in

OUTPUT	HEAD	FLOW
1.5 kW	Rated : 8m, 26ft	Rated : 6.7 L/s, 106 gpm
2 HP	Max : 16m, 52ft	Max : 8.3 L/s, 132 gpm

Solid Passage : 25 mm, 1 in

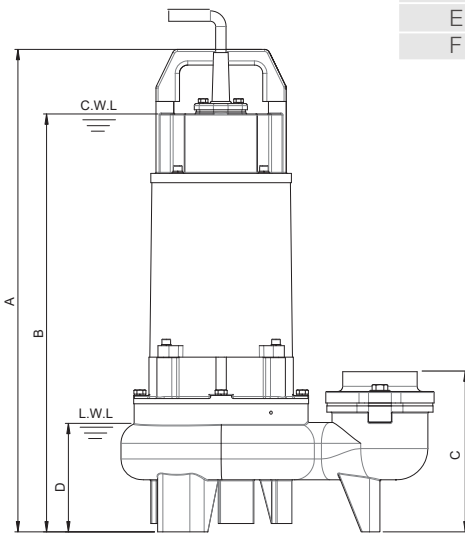

Weight : 27kg / 60 lbs

Pump Type		Electric Submersible Pumps
		1-Phase, 3-Phase
Motor	Type	Induction Motor
	Insulation	Class F
	Protector	Circle Thermal Protector
	Starter	1-Phase · Capacitor-Run, 3-Phase · D.O.L.
Lubricant		Food Grade (ISO VG32)
Impeller Type		Semi-Open Channel
Shaft Seal		Double Mechanical Seal
		Silicon Carbide VS Ceramic / Carbon
Bearings		C3 Shielded ball bearings
Cable		PVC (OSA Certified) / H07RN-F
		6m (20ft) or longer upon request.
Materials	Pump Casing	Gray Iron
	Impeller	Gray Iron
	Motor Frame	Gray Iron
	Motor Shaft	Stainless Steel
Max. Liquid Temperature		40°C (104°F)
Max. Submersion Depth		20m (66ft)
pH Range		pH 5 - pH 8

✓	
	Simplex
	Duplex
	Triplex

✓	OPTIONAL EQUIPMENT
	Additional cable 30 □ 40 □ 50 □ 75 □ Ft.
	Slide away coupling
	Impeller trims
	High Temp winding and seal liquids 190°F / 88°C

FloFab is certified :   



# SERIES LBK Non-clog Pump

SUBMITTAL DATA

50HZ

LBK-315

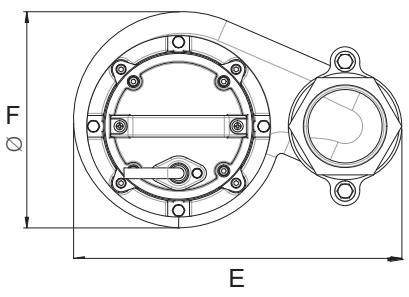
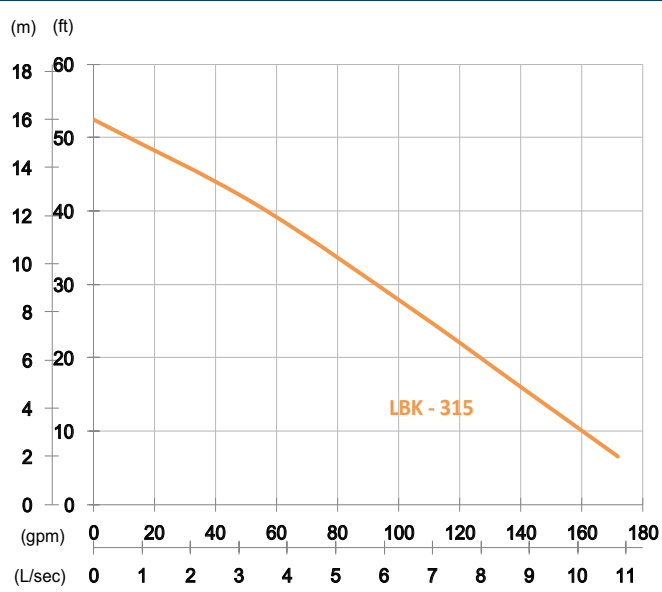

Shaft Speed : 2850 rpm Outlet : 80mm, 3in

OUTPUT	HEAD	FLOW
1.5 kW	Rated : 8m, 26ft	Rated : 6.7 L/s, 106 gpm
2 HP	Max : 16m, 52ft	Max : 10.8 L/s, 172 gpm

Solid Passage : 25 mm, 1 in

Dimensions	mm	in
A	463	18.2
B	401	15.8
C		
D	104	4.1
E	301	11.9
F	200	7.9

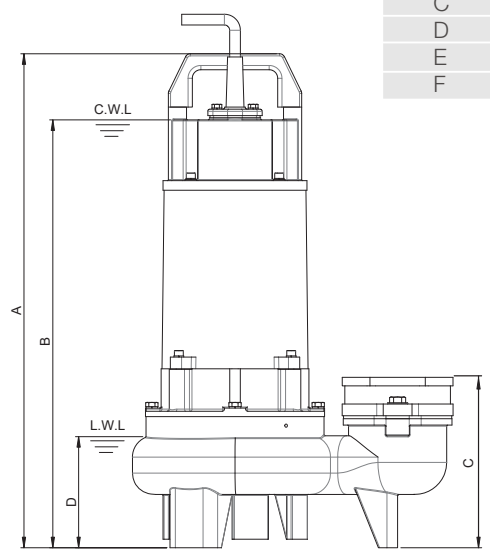

Weight : 27kg / 60 lbs

Pump Type		Electric Submersible Pumps
		1-Phase, 3-Phase
Motor	Type	Induction Motor
	Insulation	Class F
	Protector	Circle Thermal Protector
	Starter	1-Phase · Capacitor-Run, 3-Phase · D.O.L.
Lubricant		Food Grade (ISO VG32)
Impeller Type		Semi-Open Channel
Shaft Seal		Double Mechanical Seal
		Silicon Carbide VS Ceramic / Carbon
Bearings		C3 Shielded ball bearings
Cable		PVC (OSA Certified) / H07RN-F
		6m (20ft) or longer upon request.
Materials	Pump Casing	Gray Iron
	Impeller	Gray Iron
	Motor Frame	Gray Iron
	Motor Shaft	Stainless Steel
Max. Liquid Temperature		40°C (104°F)
Max. Submersion Depth		20m (66ft)
pH Range		pH 5 - pH 8

✓	
	Simplex
	Duplex
	Triplex

✓	OPTIONAL EQUIPMENT
	Additional cable 30 □ 40 □ 50 □ 75 □ Ft.
	Slide away coupling
	Impeller trims
	High Temp winding and seal liquids 190°F / 88°C





# SERIES FBK Non-clog Pump

SUBMITTAL DATA

50HZ

FBK-322

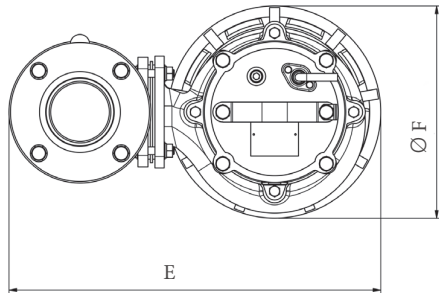

Dimensions	mm	in
A	642	25.3
B	539	21.2
C	257	10.1
D	143	5.6
E	482	19
F	275	10.8

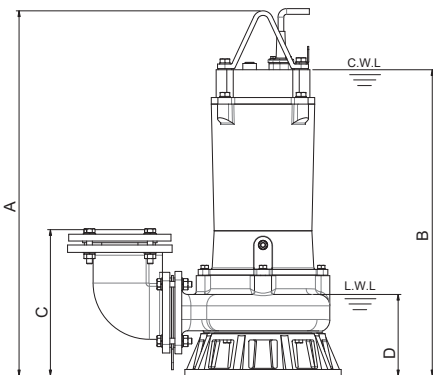

Weight : 55kg / 121 lbs

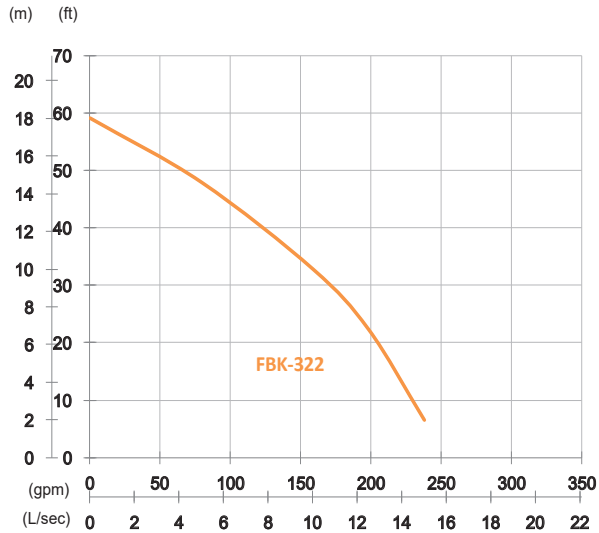

Shaft Speed : 2850 rpm

Outlet : 80mm, 3in

OUTPUT	HEAD	FLOW
2.2 kW	Rated : 10m, 33ft	Rated : 10 L/s, 158 gpm
3 HP	Max : 18m, 59ft	Max : 15 L/s, 238 gpm
Solid Passage : 25 mm, 1 in		

Pump Type		Electric Submersible Pumps
		3-Phase
Motor	Type	Induction Motor
	Insulation	Class F
	Protector	Circle Thermal Protector
	Starter	D.O.L.
Lubricant		Food Grade (ISO VG32)
Impeller Type		Semi-Open Channel
Shaft Seal		Double Mechanical Seal
		Silicon Carbide VS Ceramic / Carbon
Bearings		C3 Shielded ball bearings
Cable		PVC (CSA Certified) / H07RN-F
		10m (33ft) or longer upon request.
Materials	Pump Casing	Gray Iron
	Impeller	Gray Iron
	Motor Frame	Gray Iron
	Motor Shaft	Stainless Steel
Max. Liquid Temperature		40°C (104°F)
Max. Submersion Depth		20m (66ft)
pH Range		pH 5 - pH 8

✓	
	Simplex
	Duplex
	Triplex

✓	OPTIONAL EQUIPMENT
	Additional cable 30 □ 40 □ 50 □ 75 □ Ft.
	Slide away coupling
	Impeller trims
	High Temp winding and seal liquids 190°F / 88°C

FloFab is certified :   

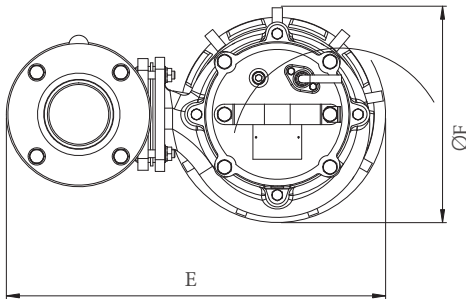

Dimensions	mm	in
A	642	25.3
B	539	21.2
C	257	10.1
D	143	5.6
E	482	19
F	275	10.8

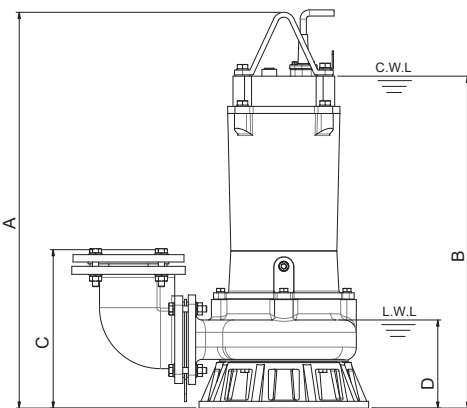

Weight : 60kg / 132 lbs

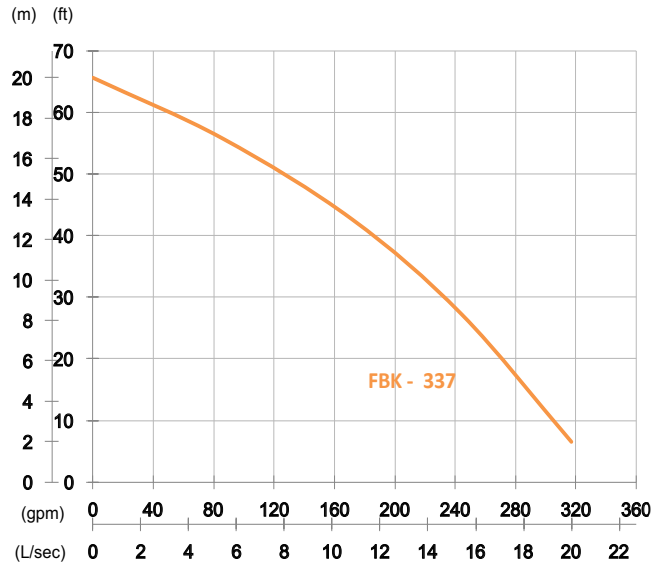

Shaft Speed : 2850 rpm

Outlet : 80mm, 3in

OUTPUT	HEAD	FLOW
3.7 kW	Rated : 13m, 43ft	Rated : 10.8 L/s, 172 gpm
5 HP	Max : 20m, 66ft	Max : 20 L/s, 317 gpm

Solid Passage : 37 mm, 1.5 in

Pump Type		Electric Submersible Pumps
		3-Phase
Motor	Type	Induction Motor
	Insulation	Class F
	Protector	Circle Thermal Protector
	Starter	D.O.L.
Lubricant		Food Grade (ISO VG32)
Impeller Type		Semi-Open Channel
Shaft Seal		Double Mechanical Seal
		Silicon Carbide VS Ceramic / Carbon
Bearings		C3 Shielded ball bearings
Cable		PVC (CSA Certified) / H07RN-F
		10m (33ft) or longer upon request.
Materials	Pump Casing	Gray Iron
	Impeller	Gray Iron
	Motor Frame	Gray Iron
	Motor Shaft	Stainless Steel
Max. Liquid Temperature		40°C (104°F)
Max. Submersion Depth		20m (66ft)
pH Range		pH 5 - pH 8

✓	
	Simplex
	Duplex
	Triplex

✓	OPTIONAL EQUIPMENT
	Additional cable 30 □ 40 □ 50 □ 75 □ Ft.
	Slide away coupling
	Impeller trims
	High Temp winding and seal liquids 190°F / 88°C



# SERIES FBK Non-clog Pump

SUBMITTAL DATA

50HZ

FBK-437

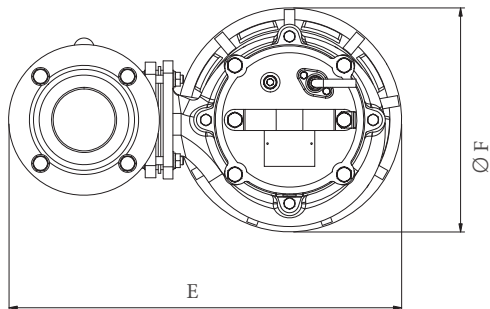
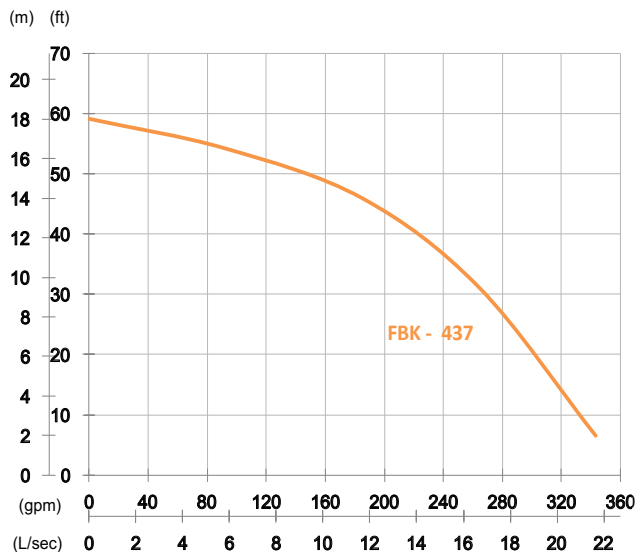

Dimensions	mm	in
A	642	25.3
B	539	21.2
C	268	10.6
D	143	5.6
E	482	19
F	275	10.8

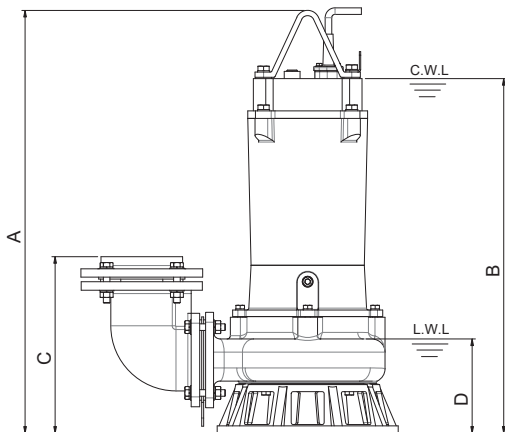

Weight : 60kg / 132 lbs

Shaft Speed : 2850 rpm

Outlet : 100mm, 4in

OUTPUT	HEAD	FLOW
3.7 kW	Rated : 14m, 46ft	Rated : 11.7 L/s, 185 gpm
5 HP	Max : 18m, 59ft	Max : 21.7 L/s, 343 gpm

Solid Passage : 37 mm, 1.5 in

Pump Type		Electric Submersible Pumps
		3-Phase
Motor	Type	Induction Motor
	Insulation	Class F
	Protector	Circle Thermal Protector
	Starter	D.O.L.
Lubricant		Food Grade (ISO VG32)
Impeller Type		Semi-Open Channel
Shaft Seal		Double Mechanical Seal
		Silicon Carbide VS Ceramic / Carbon
Bearings		C3 Shielded ball bearings
Cable		PVC (CSA Certified) / H07RN-F
		10m (33ft) or longer upon request.
Materials	Pump Casing	Gray Iron
	Impeller	Gray Iron
	Motor Frame	Gray Iron
	Motor Shaft	Stainless Steel
Max. Liquid Temperature		40°C (104°F)
Max. Submersion Depth		20m (66ft)
pH Range		pH 5 - pH 8

<input checked="" type="checkbox"/>	Simplex
<input type="checkbox"/>	Duplex
<input type="checkbox"/>	Triplex

<input checked="" type="checkbox"/>	OPTIONAL EQUIPMENT
<input type="checkbox"/>	Additional cable 30 □ 40 □ 50 □ 75 □ Ft.
<input type="checkbox"/>	Slide away coupling
<input type="checkbox"/>	Impeller trims
<input type="checkbox"/>	High Temp winding and seal liquids 190°F / 88°C

FloFab is certified :



# SERIES LBC Cutter Pump

SUBMITTAL DATA

50HZ

## LBC-75

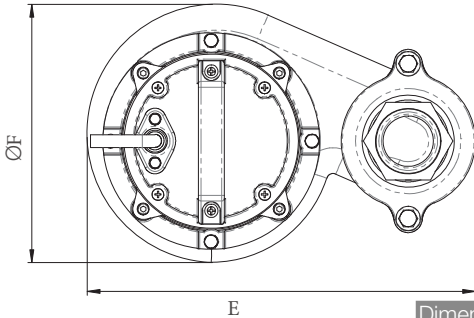
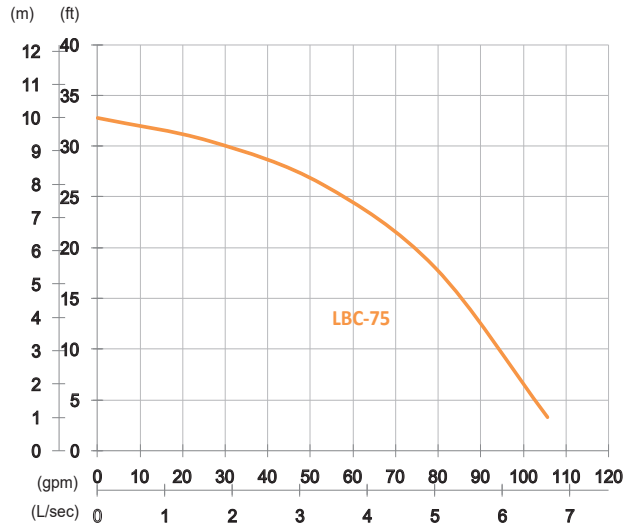

Dimensions	mm	in
A	434	17.1
B	372	14.6
C		
D	104	4.1
E	301	11.9
F	200	7.9

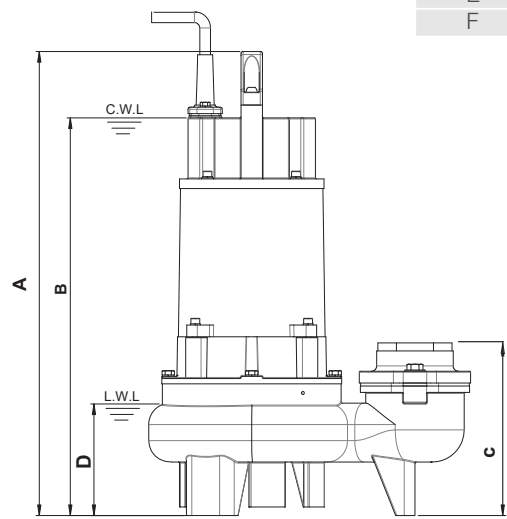

Weight : 22kg / 49 lbs

Shaft Speed : 2850 rpm

Outlet : 50mm, 2in

OUTPUT	HEAD	FLOW
0.75 kW	Rated : 8m, 26ft	Rated : 3.3 L/s, 53 gpm
<b>1 HP</b>	Max : 10m, 33ft	Max : 6.7 L/s, 106 gpm

Solid Passage : 25 mm, 1 in

Pump Type		Electric Submersible Pumps
		1-Phase, 3-Phase
Motor	Type	Induction Motor
	Insulation	Class F
	Protector	Circle Thermal Protector
	Starter	1-Phase · Capacitor-Run, 3-Phase · D.O.L.
Lubricant		Food Grade (ISO VG32)
Impeller Type		Semi-Open Channel Cutter
Shaft Seal		Double Mechanical Seal
		Silicon Carbide VS Ceramic / Carbon
Bearings		C3 Shielded ball bearings
Cable		PVC (CSA Certified) / H07RN-F
		6m (20ft) or longer upon request.
Materials	Pump Casing	Gray Iron
	Impeller	Gray Iron
	Motor Frame	Gray Iron
	Motor Shaft	Stainless Steel
Max. Liquid Temperature		40°C (104°F)
Max. Submersion Depth		20m (66ft)
pH Range		pH 5 - pH 8

✓	OPTIONAL EQUIPMENT
Simplex	Additional cable 30 □ 40 □ 50 □ 75 □ Ft.
Duplex	Slide away coupling
Triplex	Impeller trims
	High Temp winding and seal liquids 190°F / 88°C



## LBC-215

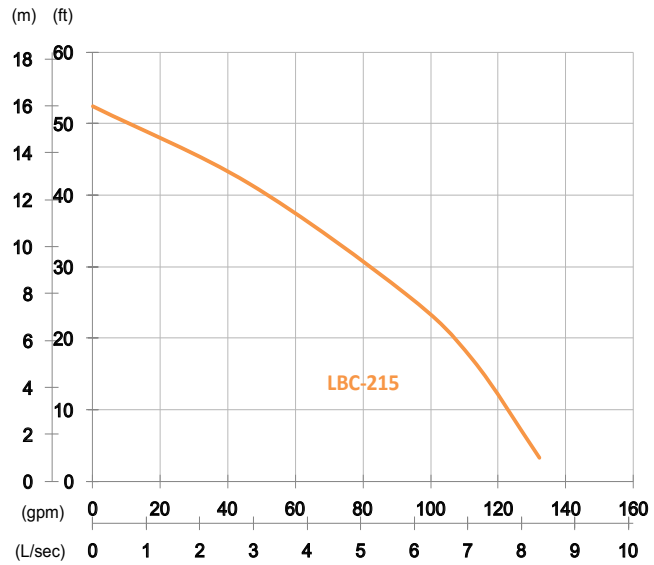

Shaft Speed : 2850 rpm

Outlet : 50mm, 2in

OUTPUT	HEAD	FLOW
1.5 kW	Rated : 8m, 26ft	Rated : 5.8 L/s, 92 gpm
2 HP	Max : 16m, 52ft	Max : 8.3 L/s, 132 gpm

Solid Passage : 27 mm, 1.1 in

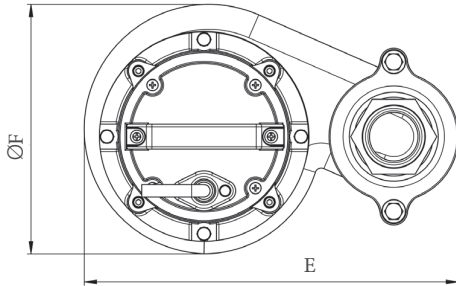

Dimensions	mm	in
A	463	18.2
B	401	15.8
C		
D	104	4.1
E	301	11.9
F	200	7.9

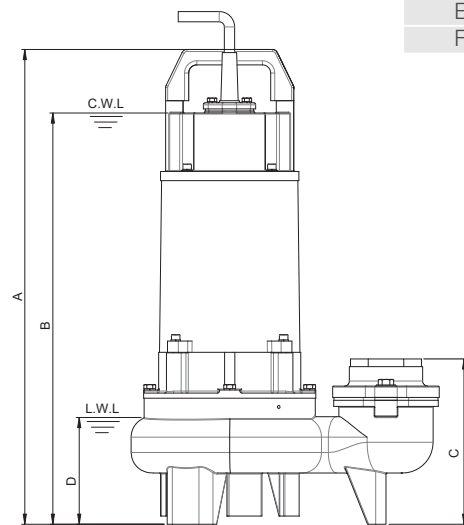

Weight : 27kg / 60 lbs

Pump Type		Electric Submersible Pumps
		1-Phase, 3-Phase
Motor	Type	Induction Motor
	Insulation	Class F
	Protector	Circle Thermal Protector
	Starter	1-Phase · Capacitor-Run, 3-Phase · D.O.L.
Lubricant		Food Grade (ISO VG32)
Impeller Type		Semi-Open Channel Cutter
Shaft Seal		Double Mechanical Seal
		Silicon Carbide VS Ceramic / Carbon
Bearings		C3 Shielded ball bearings
Cable		PVC (CSA Certified) / H07RN-F
		6m (20ft) or longer upon request.
Materials	Pump Casing	Gray Iron
	Impeller	Gray Iron
	Motor Frame	Gray Iron
	Motor Shaft	Stainless Steel
Max. Liquid Temperature		40°C (104°F)
Max. Submersion Depth		20m (66ft)
pH Range		pH 5 - pH 8

✓	
	Simplex
	Duplex
	Triplex

✓	OPTIONAL EQUIPMENT
	Additional cable 30 □ 40 □ 50 □ 75 □ Ft.
	Slide away coupling
	Impeller trims
	High Temp winding and seal liquids 190°F / 88°C



# SERIES LBC Cutter Pump

**SUBMITTAL DATA**

**50HZ**

**LBC-315**

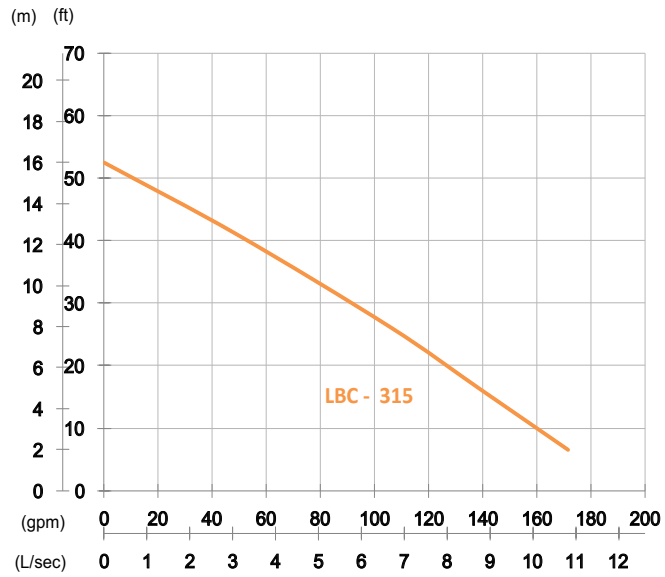

Shaft Speed : 2850 rpm

Outlet : 80mm, 3in

OUTPUT	HEAD	FLOW
1.5 kW	Rated : 8m, 26ft	Rated : 6.7 L/s, 106 gpm
2 HP	Max : 16m, 52ft	Max : 10.8 L/s, 172 gpm

Solid Passage : 27 mm, 1.1 in

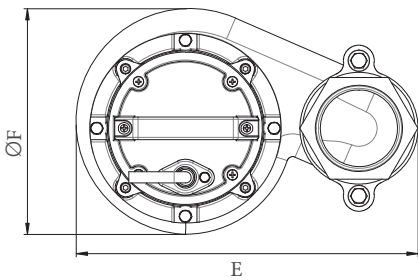

Dimensions	mm	
A	463	18.2
B	401	15.8
C		
D	104	4.1
E	301	11.9
F	200	7.9

Pump Type		Electric Submersible Pumps
		1-Phase, 3-Phase
Motor	Type	Induction Motor
	Insulation	Class F
	Protector	Circle Thermal Protector
	Starter	1-Phase · Capacitor-Run, 3-Phase · D.O.L.
Lubricant		Food Grade (ISO VG32)
Impeller Type		Semi-Open Channel Cutter
Shaft Seal		Double Mechanical Seal
		Silicon Carbide VS Ceramic / Carbon
Bearings		C3 Shielded ball bearings
Cable		PVC (CSA Certified) / H07RN-F
		6m (20ft) or longer upon request.
Materials	Pump Casing	Gray Iron
	Impeller	Gray Iron
	Motor Frame	Gray Iron
	Motor Shaft	Stainless Steel
Max. Liquid Temperature		40°C (104°F)
Max. Submersion Depth		20m (66ft)
pH Range		pH 5 - pH 8

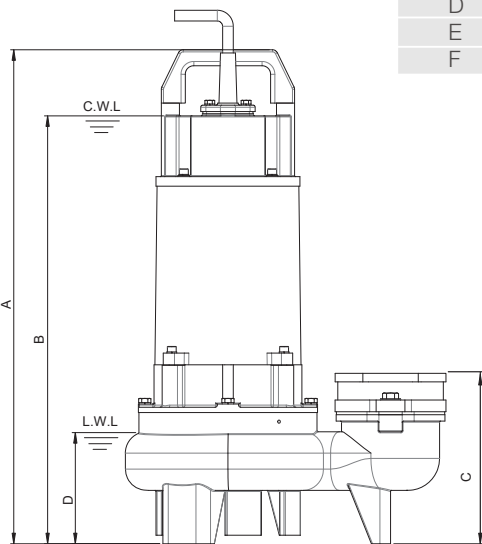

Weight : 27kg / 60 lbs

✓	OPTIONAL EQUIPMENT
Simplex	Additional cable 30 □ 40 □ 50 □ 75 □ Ft.
Duplex	Slide away coupling
Triplex	Impeller trims
	High Temp winding and seal liquids 190°F / 88°C





FBC-322

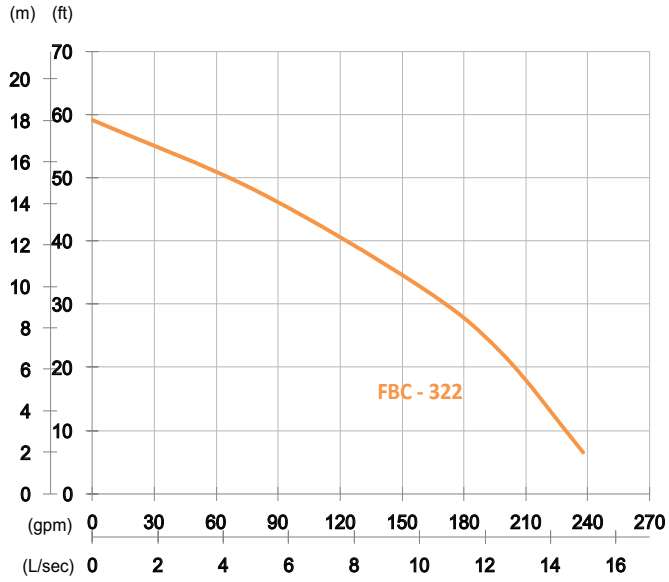

Shaft Speed : 2850 rpm

Outlet : 80mm, 3in

OUTPUT	HEAD	FLOW
2.2 kW	Rated : 10m, 33ft	Rated : 10 L/s, 158 gpm
3 HP	Max : 18m, 59ft	Max : 15 L/s, 238 gpm

Solid Passage : 27 mm, 1.1 in

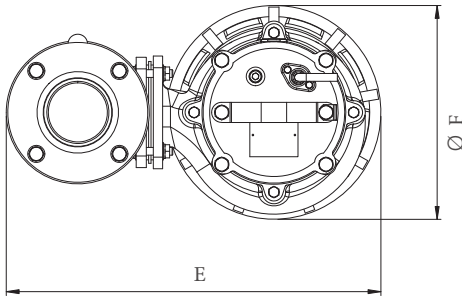

Dimensions	mm	in
A	642	25.3
B	539	21.2
C	257	10.1
D	143	5.6
E	482	19
F	275	10.8

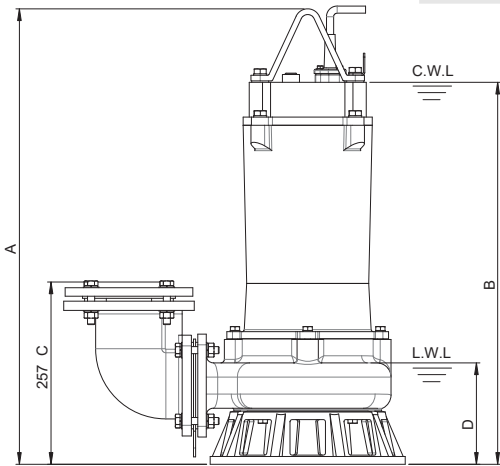

Weight : 55kg / 121 lbs

Pump Type		Electric Submersible Pumps
		3-Phase
Motor	Type	Induction Motor
	Insulation	Class F
	Protector	Circle Thermal Protector
	Starter	D.O.L.
Lubricant		Food Grade (ISO VG32)
Impeller Type		Semi-Open Channel Cutter
Shaft Seal		Double Mechanical Seal
		Silicon Carbide VS Ceramic / Carbon
Bearings		C3 Shielded ball bearings
Cable		PVC (CSA Certified) / H07RN-F
		10m (33ft) or longer upon request.
Materials	Pump Casing	Gray Iron
	Impeller	Gray Iron
	Motor Frame	Gray Iron
	Motor Shaft	Stainless Steel
Max. Liquid Temperature		40°C (104°F)
Max. Submersion Depth		20m (66ft)
pH Range		pH 5 - pH 8

✓	
	Simplex
	Duplex
	Triplex

✓	OPTIONAL EQUIPMENT
	Additional cable 30 □ 40 □ 50 □ 75 □ Ft.
	Slide away coupling
	Impeller trims
	High Temp winding and seal liquids 190°F / 88°C

**FBC-337**

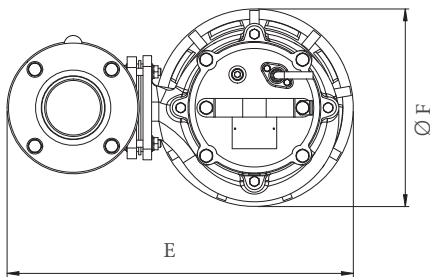
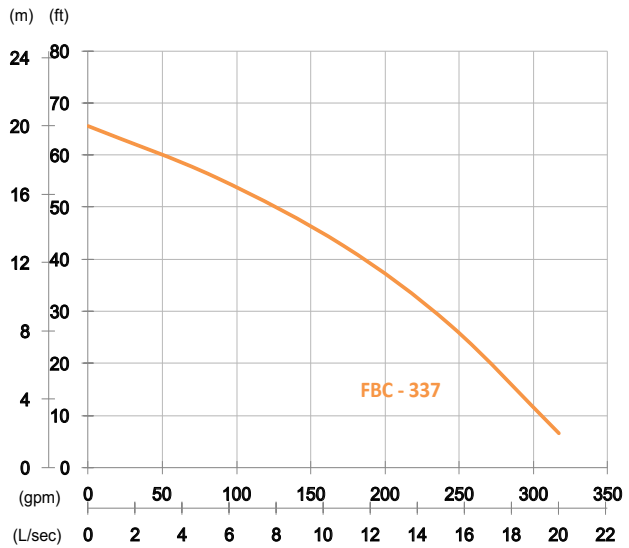

Dimensions	mm	in
A	642	25.3
B	539	21.2
C	257	10.1
D	143	5.6
E	482	19
F	275	10.8

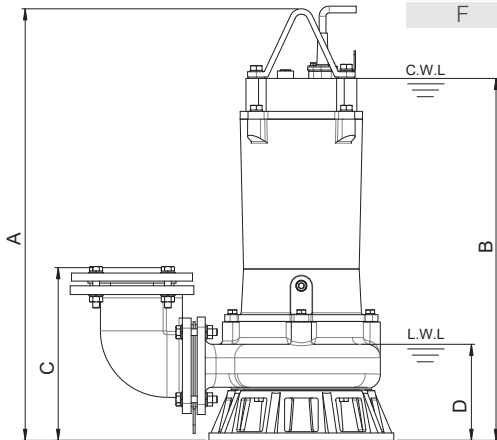

Weight : 60kg / 132 lbs

Shaft Speed : 2850 rpm

Outlet : 80mm, 3in

OUTPUT	HEAD	FLOW
3.7 kW	Rated : 13m, 43ft	Rated : 10.8 L/s, 172 gpm
5 HP	Max : 20m, 66ft	Max : 20 L/s, 317 gpm

Solid Passage : 37 mm, 1.5 in

Pump Type		Electric Submersible Pumps
		3-Phase
Motor	Type	Induction Motor
	Insulation	Class F
	Protector	Circle Thermal Protector
	Starter	D.O.L.
Lubricant		Food Grade (ISO VG32)
Impeller Type		Semi-Open Channel Cutter
Shaft Seal		Double Mechanical Seal
		Silicon Carbide VS Ceramic / Carbon
Bearings		C3 Shielded ball bearings
Cable		PVC (CSA Certified) / H07RN-F
		10m (33ft) or longer upon request.
Materials	Pump Casing	Gray Iron
	Impeller	Gray Iron
	Motor Frame	Gray Iron
	Motor Shaft	Stainless Steel
Max. Liquid Temperature		40°C (104°F)
Max. Submersion Depth		20m (66ft)
pH Range		pH 5 - pH 8

<input checked="" type="checkbox"/>	
<input type="checkbox"/>	Simplex
<input type="checkbox"/>	Duplex
<input type="checkbox"/>	Triplex

<input checked="" type="checkbox"/>	OPTIONAL EQUIPMENT
<input type="checkbox"/>	Additional cable 30 □ 40 □ 50 □ 75 □ Ft.
<input type="checkbox"/>	Slide away coupling
<input type="checkbox"/>	Impeller trims
<input type="checkbox"/>	High Temp winding and seal liquids 190°F / 88°C

FBC-437

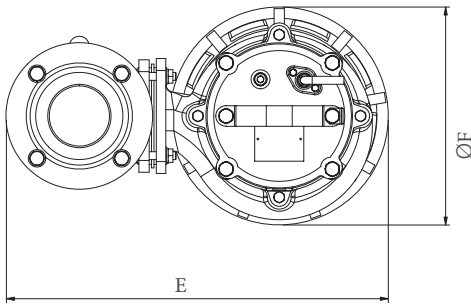
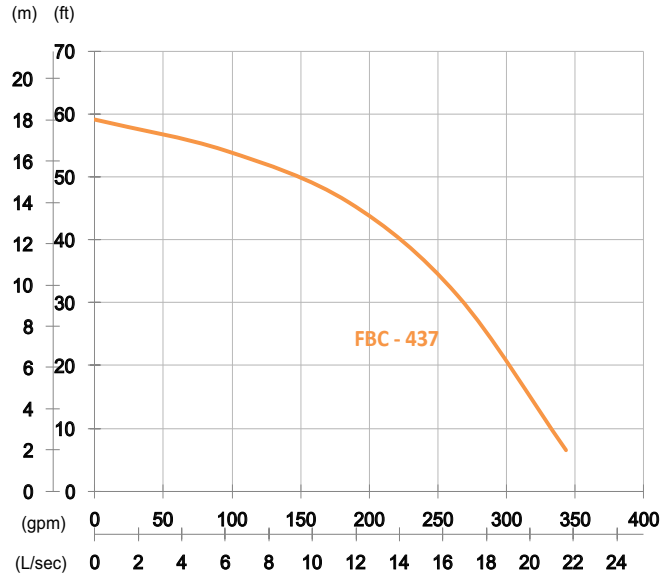

Dimensions	mm	in
A	642	25.3
B	539	21.2
C	268	10.6
D	143	5.6
E	482	19
F	275	10.8

Shaft Speed : 2850 rpm

Outlet : 100mm, 4in

OUTPUT	HEAD	FLOW
3.7 kW	Rated : 14m, 46ft	Rated : 11.7 L/s, 185 gpm
5 HP	Max : 18m, 59ft	Max : 21.7 L/s, 343 gpm

Solid Passage : 37 mm, 1.5 in

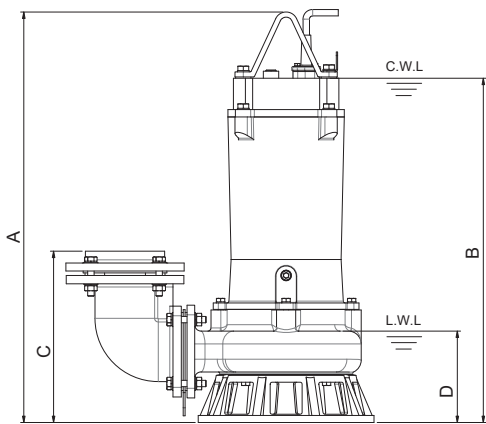

unit : mm

Weight : 60kg / 132 lbs

Pump Type		Electric Submersible Pumps
		3-Phase
Motor	Type	Induction Motor
	Insulation	Class F
	Protector	Circle Thermal Protector
	Starter	D.O.L.
Lubricant		Food Grade (ISO VG32)
Impeller Type		Semi-Open Channel Cutter
Shaft Seal		Double Mechanical Seal
		Silicon Carbide VS Ceramic / Carbon
Bearings		C3 Shielded ball bearings
Cable		PVC (CSA Certified) / H07RN-F
		10m (33ft) or longer upon request.
Materials	Pump Casing	Gray Iron
	Impeller	Gray Iron
	Motor Frame	Gray Iron
	Motor Shaft	Stainless Steel
Max. Liquid Temperature		40°C (104°F)
Max. Submersion Depth		20m (66ft)
pH Range		pH 5 - pH 8

<input checked="" type="checkbox"/>	Simplex
<input type="checkbox"/>	Duplex
<input type="checkbox"/>	Triplex

<input checked="" type="checkbox"/>	OPTIONAL EQUIPMENT
<input type="checkbox"/>	Additional cable 30 □ 40 □ 50 □ 75 □ Ft.
<input type="checkbox"/>	Slide away coupling
<input type="checkbox"/>	Impeller trims
<input type="checkbox"/>	High Temp winding and seal liquids 190°F / 88°C

#### FGC-11

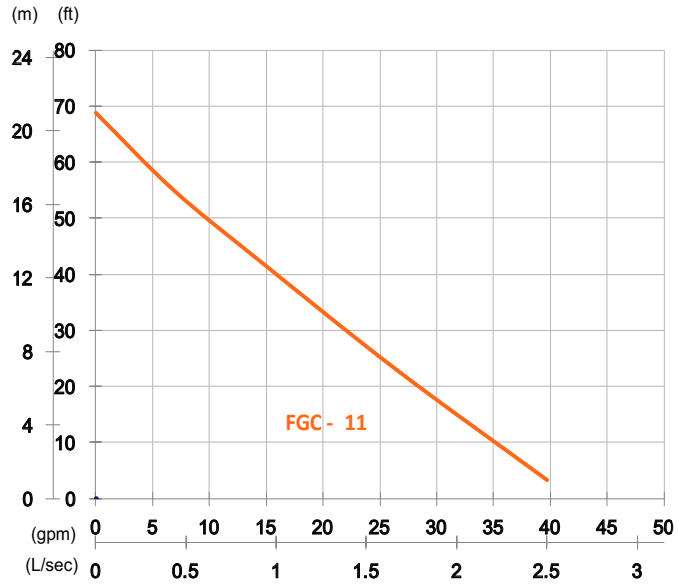
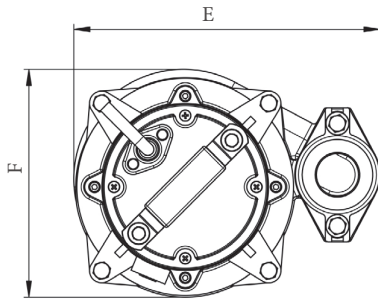

Shaft Speed : 2850 rpm

Outlet : 32mm, 1.25in

OUTPUT	HEAD	FLOW
1.1 kW	Rated : 13m, 43ft	Rated : 0.8 L/s, 13 gpm
1.5 HP	Max : 21m, 69ft	Max : 2.5 L/s, 40 gpm

Dimensions	mm	in
A	455	18
B	520	20.5
C	136	5.4
D	189	7.4
E	251	9.9
F	187	7.4
G	83	3.3

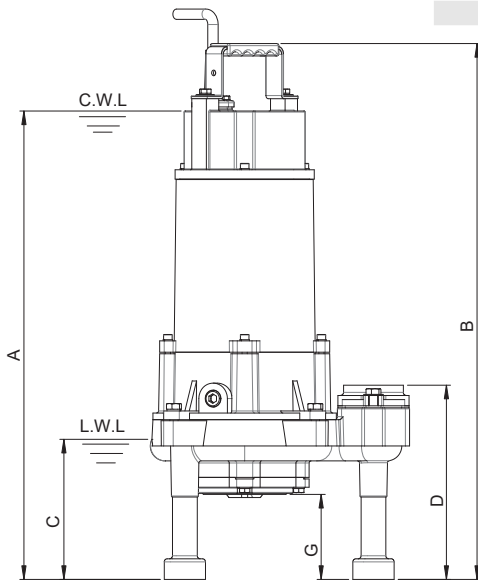

Weight : 27kg / 60 lbs

Pump Type		Electric Submersible Pumps
		1-Phase, 3-Phase
Motor	Type	Induction Motor
	Insulation	Class F
	Protector	Circle Thermal Protector
	Starter	1-Phase · Capacitor-Run, 3-Phase · D.O.L.
Lubricant		Food Grade (ISO VG32)
Impeller Type		Vortex
Shaft Seal		Double Mechanical Seal
		Silicon Carbide VS Ceramic / Carbon
Bearings		C3 Shielded ball bearings
Cable		PVC (CSA Certified) / H07RN-F
		10m (33ft) or longer upon request.
Materials	Pump Casing	Gray Iron
	Impeller	Gray Iron
	Motor Frame	Gray Iron
	Motor Shaft	Stainless Steel
Grinder Set		Chromium Iron
Max. Liquid Temperature		40°C (104°F)
Max. Submersion Depth		20m (66ft)
pH Range		pH 5 - pH 8

✓	OPTIONAL EQUIPMENT
Simplex	Additional cable 30 □ 40 □ 50 □ 75 □ Ft.
Duplex	Slide away coupling
Triplex	Impeller trims
	High Temp winding and seal liquids 190°F / 88°C

**FGC-15**

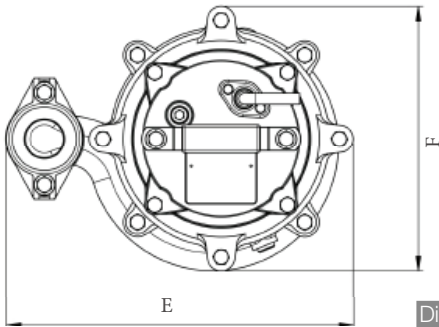

Dimensions	mm	in
A	583	23
B	514	20.2
C	194	7.6
D	160	6.3
E	314	12.4
F	239	9.4
G	83	3.3

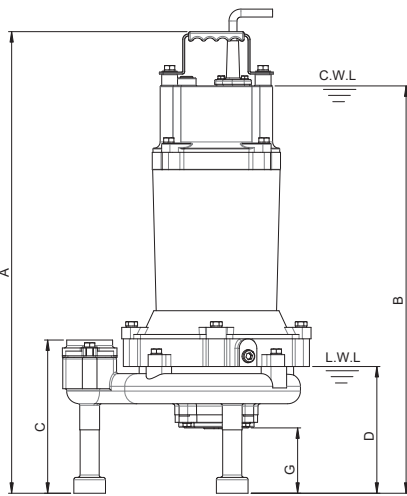

Weight : 35kg / 77 lbs

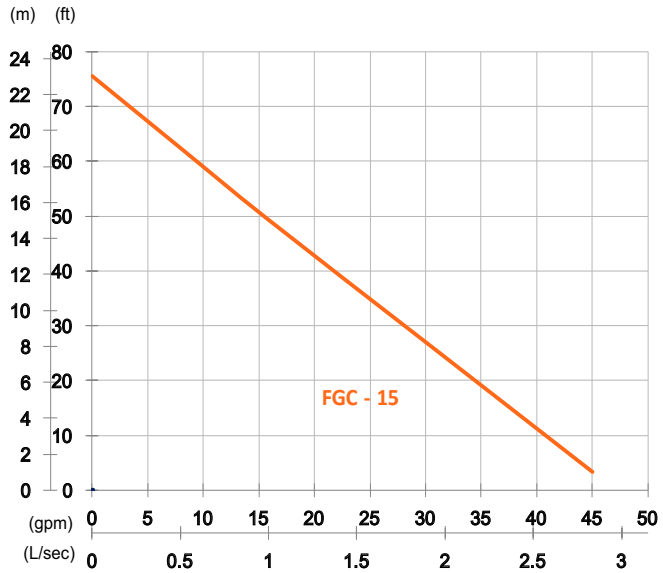

Shaft Speed : 2850 rpm

Outlet : 32mm, 1.25in

OUTPUT	HEAD	FLOW
1.5 kW	Rated : 15m, 49ft	Rated : 1 L/s, 16 gpm
2 HP	Max : 23m, 75ft	Max : 2.8 L/s, 45 gpm

Pump Type		Electric Submersible Pumps
		1-Phase, 3-Phase
Motor	Type	Induction Motor
	Insulation	Class F
	Protector	Circle Thermal Protector
	Starter	1-Phase · Capacitor-Start, 3-Phase · D.O.L.
Lubricant		Food Grade (ISO VG32)
Impeller Type		Vortex
Shaft Seal		Double Mechanical Seal Silicon Carbide VS Ceramic / Carbon
Bearings		C3 Shielded ball bearings
Cable		PVC (CSA Certified) / H07RN-F 10m (33ft) or longer upon request.
Materials	Pump Casing	Gray Iron
	Impeller	Gray Iron
	Motor Frame	Gray Iron
	Motor Shaft	Stainless Steel
Grinder Set		Chromium Iron
Max. Liquid Temperature		40°C (104°F)
Max. Submersion Depth		20m (66ft)
pH Range		pH 5 - pH 8

✓	
	Simplex
	Duplex
	Triplex

✓	OPTIONAL EQUIPMENT
	Additional cable 30 □ 40 □ 50 □ 75 □ Ft.
	Slide away coupling
	Impeller trims
	High Temp winding and seal liquids 190°F / 88°C

FGC-22

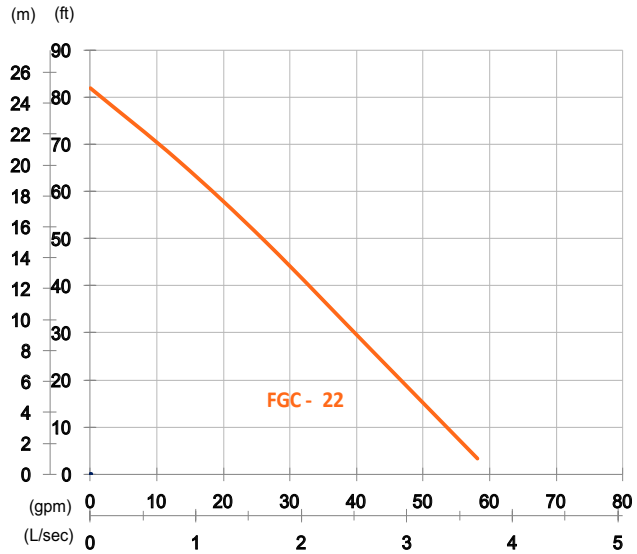

Shaft Speed : 2850 rpm

Outlet : 50mm, 2in

OUTPUT	HEAD	FLOW
2.2 kW	Rated : 15m, 49ft	Rated : 1.7 L/s, 26 gpm
3 HP	Max : 25m, 82ft	Max : 3.7 L/s, 58 gpm

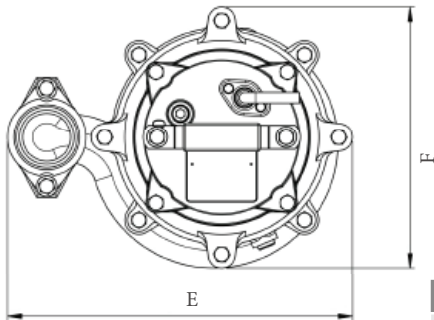

Dimensions	mm	in
A	583	23
B	514	20.2
C	198	7.8
D	160	6.3
E	316	12.4
F	239	9.4
G	83	3.3

Pump Type		Electric Submersible Pumps
		3-Phase
Motor	Type	Induction Motor
	Insulation	Class F
	Protector	Circle Thermal Protector
	Starter	D.O.L.
Lubricant		Food Grade (ISO VG32)
Impeller Type		Vortex
Shaft Seal		Double Mechanical Seal Silicon Carbide VS Ceramic / Carbon
Bearings		C3 Shielded ball bearings
Cable		PVC (CSA Certified) / H07RN-F 10m (33ft) or longer upon request.
Materials	Pump Casing	Gray Iron
	Impeller	Gray Iron
	Motor Frame	Gray Iron
	Motor Shaft	Stainless Steel
Grinder Set		Chromium Iron
Max. Liquid Temperature		40°C (104°F)
Max. Submersion Depth		20m (66ft)
pH Range		pH 5 - pH 8

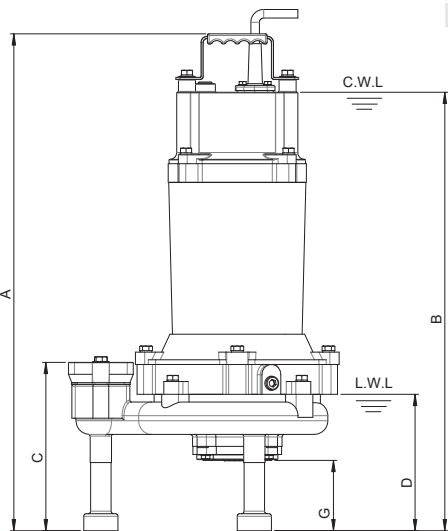

Weight : 35kg / 77 lbs

✓	OPTIONAL EQUIPMENT
Simplex	Additional cable 30 □ 40 □ 50 □ 75 □ Ft.
Duplex	Slide away coupling
Triplex	Impeller trims
	High Temp winding and seal liquids 190°F / 88°C



# SERIES FGC Grinder Pump

SUBMITTAL DATA

50HZ

FGC-37

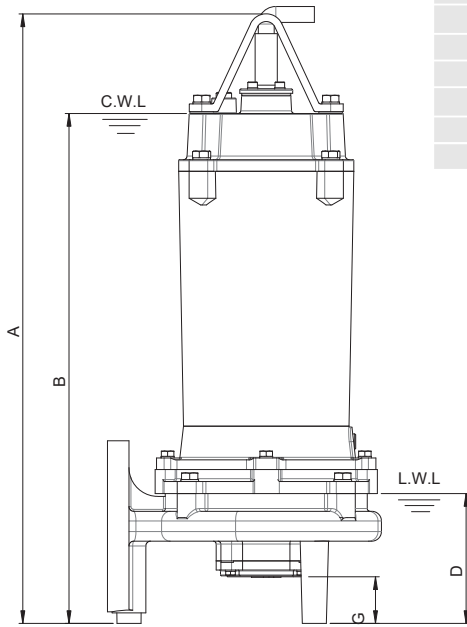
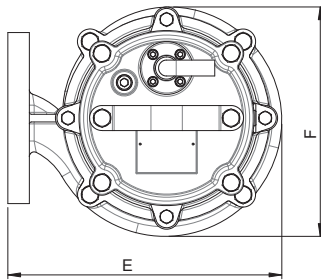

Weight : 55kg / 121 lbs

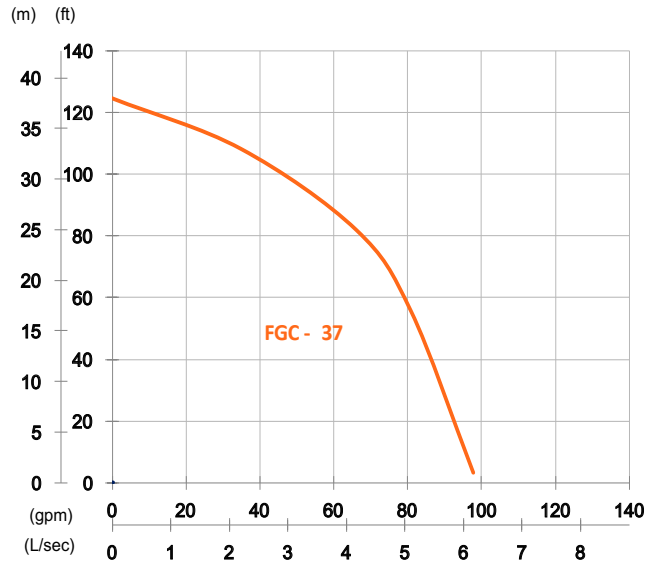

Shaft Speed : 2850 rpm

Outlet : 50mm, 2in

OUTPUT	HEAD	FLOW
3.7 kW	Rated : 25m, 82ft	Rated : 4.2 L/s, 66 gpm
5 HP	Max : 38m, 125ft	Max : 6.2 L/s, 98 gpm

Dimensions	mm	in
A	634	25
B	530	20.9
C	----	----
D	135	5.3
E	285	11.2
F	238	9.4
G	49	2

Pump Type		Electric Submersible Pumps
		3-Phase
Motor	Type	Induction Motor
	Insulation	Class F
	Protector	Circle Thermal Protector
	Starter	D.O.L.
Lubricant		Food Grade (ISO VG32)
Impeller Type		Vortex
Shaft Seal		Double Mechanical Seal Silicon Carbide VS Ceramic / Carbon
Bearings		C3 Shielded ball bearings
Cable		PVC (CSA Certified) / H07RN-F 10m (33ft) or longer upon request.
Materials	Pump Casing	Gray Iron
	Impeller	Gray Iron
	Motor Frame	Gray Iron
	Motor Shaft	Stainless Steel
	Grinder Set	Chromium Iron
Max. Liquid Temperature		40°C (104°F)
Max. Submersion Depth		20m (66ft)
pH Range		pH 5 - pH 8

✓	
	Simplex
	Duplex
	Triplex

✓	OPTIONAL EQUIPMENT
	Additional cable 30 □ 40 □ 50 □ 75 □ Ft.
	Slide away coupling
	Impeller trims
	High Temp winding and seal liquids 190°F / 88°C

FloFab is certified :   



# SERIES FGC Grinder Pump

SUBMITTAL DATA

50HZ

FGC-55

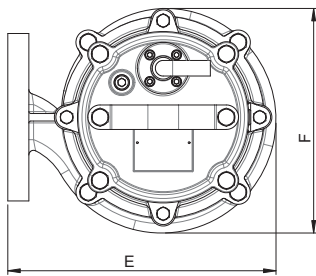
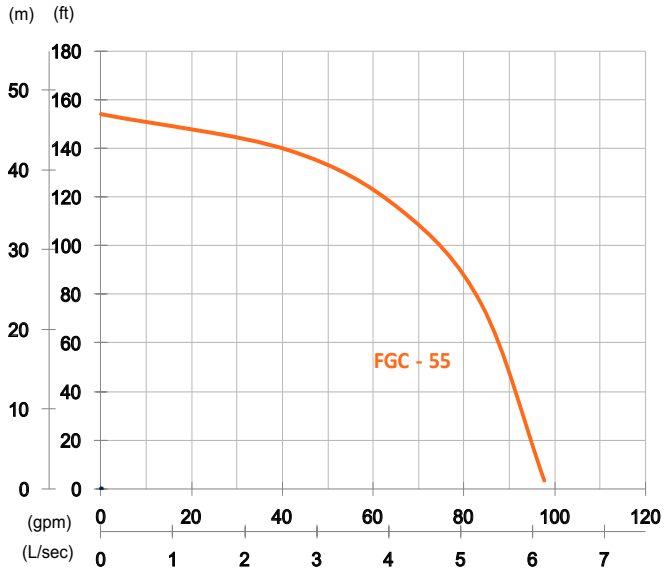

Shaft Speed : 2850 rpm

Outlet : 50mm, 2in

OUTPUT	HEAD	FLOW
5.5 kW	Rated : 35m, 115ft	Rated : 4.2 L/s, 66 gpm
7.5 HP	Max : 47m, 154ft	Max : 6.2 L/s, 98 gpm

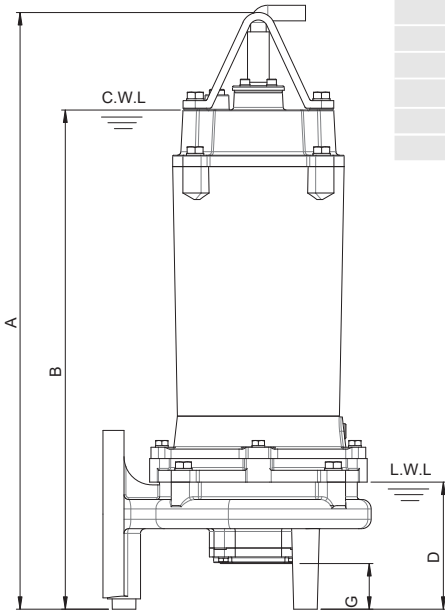

Dimensions	mm	in
A	634	25
B	530	20.9
C	---	---
D	135	5.3
E	285	11.2
F	238	9.4
G	49	2

Weight : 61kg / 134 lbs

Pump Type		Electric Submersible Pumps
		3-Phase
Motor	Type	Induction Motor
	Insulation	Class F
	Protector	Circle Thermal Protector
	Starter	D.O.L.
Lubricant		Food Grade (ISO VG32)
Impeller Type		Vortex
Shaft Seal		Double Mechanical Seal Silicon Carbide VS Ceramic / Carbon
Bearings		C3 Shielded ball bearings
Cable		PVC (CSA Certified) / H07RN-F 10m (33ft) or longer upon request.
Materials	Pump Casing	Gray Iron
	Impeller	Gray Iron
	Motor Frame	Gray Iron
	Motor Shaft	Stainless Steel
	Grinder Set	Chromium Iron
Max. Liquid Temperature		40°C (104°F)
Max. Submersion Depth		20m (66ft)
pH Range		pH 5 - pH 8

✓	
	Simplex
	Duplex
	Triplex

✓	OPTIONAL EQUIPMENT
	Additional cable 30 □ 40 □ 50 □ 75 □ Ft.
	Slide away coupling
	Impeller trims
	High Temp winding and seal liquids 190°F / 88°C

FloFab is certified :





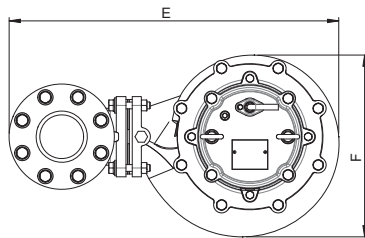

Dimensions	mm	in
A	750	29.5
B	673	26.5
C	342	13.5
D	259	10.2
E	580	22.8
F	320	12.6

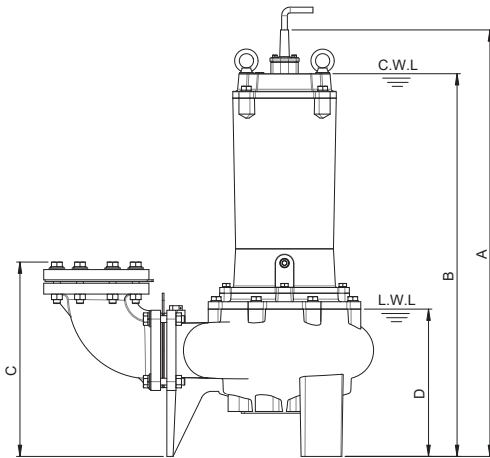

Weight : 94kg / 207 lbs

<input checked="" type="checkbox"/>	
<input type="checkbox"/>	Simplex
<input type="checkbox"/>	Duplex
<input type="checkbox"/>	Triplex

<input checked="" type="checkbox"/>	OPTIONAL EQUIPMENT
<input type="checkbox"/>	Additional cable 30 □ 40 □ 50 □ 75 □ Ft.
<input type="checkbox"/>	Slide away coupling
<input type="checkbox"/>	Impeller trims
<input type="checkbox"/>	High Temp winding and seal liquids 190°F / 88°C

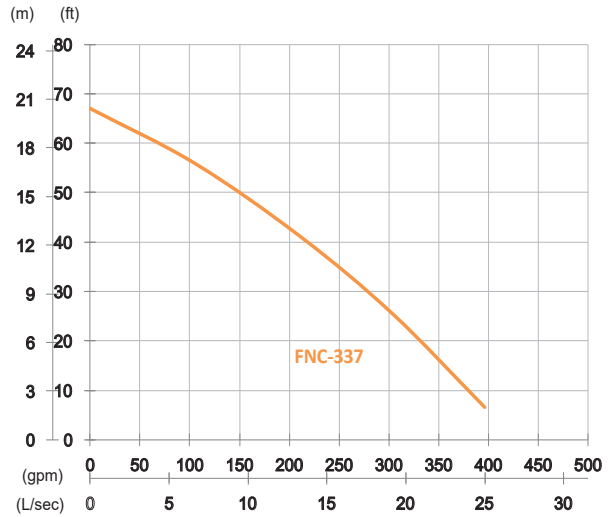

Shaft Speed : 1450 rpm

Outlet : 80mm, 3in

OUTPUT	HEAD	FLOW
3.7 kW	Rated : 12.5m, 41ft	Rated : 13.3 L/s, 211 gpm
5 HP	Max : 20.4m, 67ft	Max : 25 L/s, 396 gpm

Solid Passage : 76mm, 3in

Pump Type	Electric Submersible Pumps	
	3-Phase	
Motor	Type	Induction Motor
	Insulation	Class F
	Protector	Circle Thermal Protector
	Starter	D.O.L.
Lubricant	Food Grade (ISO VG32)	
Impeller Type	Single Channel	
Shaft Seal	Double Mechanical Seal	
	Silicon Carbide VS Ceramic / Carbon	
Bearings	C3 Shielded ball bearings	
Cable	PVC (CSA Certified) / H07RN-F	
	10m (33ft) or longer upon request.	
Materials	Pump Casing	Gray Iron
	Impeller	Gray Iron
	Motor Frame	Gray Iron
	Motor Shaft	Stainless Steel
	Mouth Ring	Copper Alloy
Max. Liquid Temperature	40°C (104°F)	
Max. Submersion Depth	20m (66ft)	
pH Range	pH 5 - pH 8	

#### FNC-437

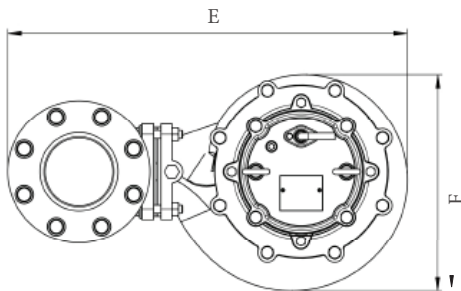
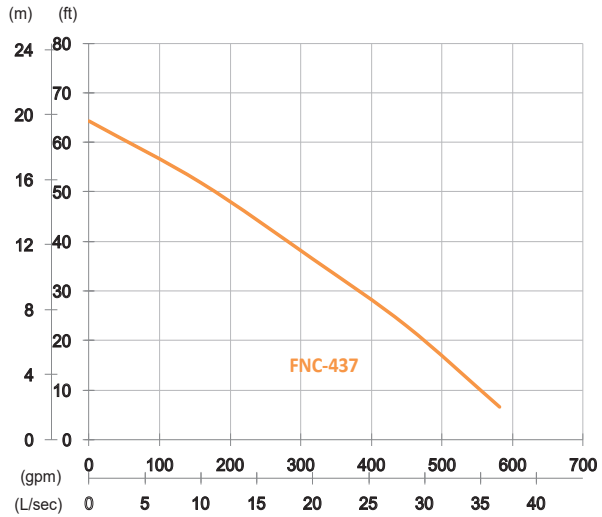

Shaft Speed : 1450 rpm

Outlet : 100mm, 4in

OUTPUT	HEAD	FLOW
3.7 kW	Rated : 11.1m, 36ft	Rated : 20 L/s, 317 gpm
5 HP	Max : 19.6m, 64ft	Max : 36.6 L/s, 581 gpm
Solid Passage : 76mm, 3in		

Dimensions	mm	in
A	750	29.5
B	673	26.5
C	349	13.7
D	259	10.2
E	589	23.2
F	320	12.6

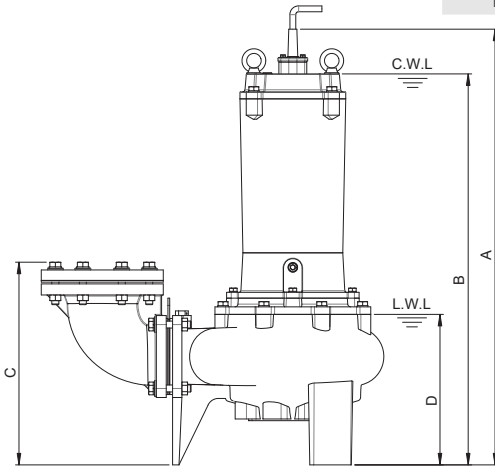

Weight : 97kg / 214 lbs

Pump Type		Electric Submersible Pumps
		3-Phase
Motor	Type	Induction Motor
	Insulation	Class F
	Protector	Circle Thermal Protector
	Starter	D.O.L.
Lubricant		Food Grade (ISO VG32)
Impeller Type		Single Channel
Shaft Seal		Double Mechanical Seal
		Silicon Carbide VS Ceramic / Carbon
Bearings		C3 Shielded ball bearings
Cable		PVC (CSA Certified) / H07RN-F
		10m (33ft) or longer upon request.
Materials	Pump Casing	Gray Iron
	Impeller	Gray Iron
	Motor Frame	Gray Iron
	Motor Shaft	Stainless Steel
	Mouth Ring	Copper Alloy
Max. Liquid Temperature		40°C (104°F)
Max. Submersion Depth		20m (66ft)
pH Range		pH 5 - pH 8

<input checked="" type="checkbox"/>	Simplex
<input type="checkbox"/>	Duplex
<input type="checkbox"/>	Triplex

<input checked="" type="checkbox"/>	OPTIONAL EQUIPMENT
<input type="checkbox"/>	Additional cable 30 □ 40 □ 50 □ 75 □ Ft.
<input type="checkbox"/>	Slide away coupling
<input type="checkbox"/>	Impeller trims
<input type="checkbox"/>	High Temp winding and seal liquids 190°F / 88°C

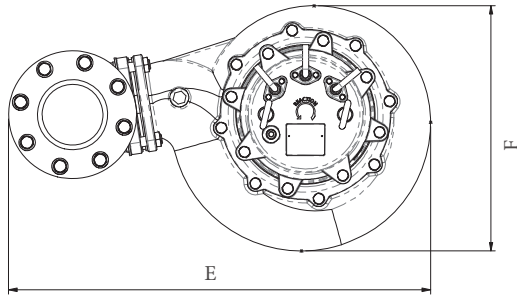

Dimensions	mm	in
A	838	33
B	758	29.8
C	364	14.3
D	270	10.6
E	693	27.3
F	403	15.9

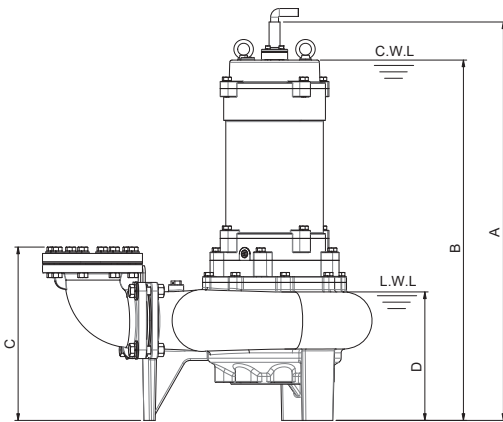

Weight : 132kg / 291 lbs

<input checked="" type="checkbox"/>	Simplex
<input type="checkbox"/>	Duplex
<input type="checkbox"/>	Triplex

<input checked="" type="checkbox"/>	OPTIONAL EQUIPMENT
<input type="checkbox"/>	Additional cable 30 □ 40 □ 50 □ 75 □ Ft.
<input type="checkbox"/>	Slide away coupling
<input type="checkbox"/>	Impeller trims
<input type="checkbox"/>	High Temp winding and seal liquids 190°F / 88°C

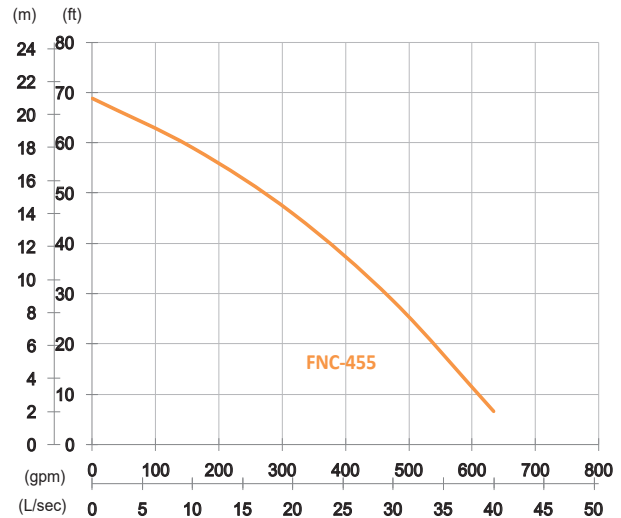

Shaft Speed : 1450 rpm

Outlet : 100mm, 4in

OUTPUT	HEAD	FLOW
5.5 kW	Rated : 14m, 46ft	Rated : 20 L/s, 317 gpm
7.5 HP	Max : 21m, 69ft	Max : 40 L/s, 634 gpm

Solid Passage : 76mm, 3in

Pump Type		Electric Submersible Pumps
		3-Phase
Motor	Type	Induction Motor
	Insulation	Class F
	Protector	Star-Delta • Miniature Thermal Sensors D.O.L. • Circle Thermal Protector
	Starter	Star-Delta , D.O.L.
Lubricant		Food Grade (ISO VG32)
Impeller Type		Single Channel
Shaft Seal		Double Mechanical Seal Silicon Carbide VS Ceramic / Carbon
Bearings		C3 Shielded ball bearings
Cable		PVC (CSA Certified) / H07RN-F 10m (33ft) or longer upon request.
Materials	Pump Casing	Gray Iron
	Impeller	Gray Iron
	Motor Frame	Gray Iron
	Motor Shaft	Stainless Steel
	Mouth Ring	Copper Alloy
Max. Liquid Temperature		40°C (104°F)
Max. Submersion Depth		20m (66ft)
pH Range		pH 5 - pH 8

#### FNC-655

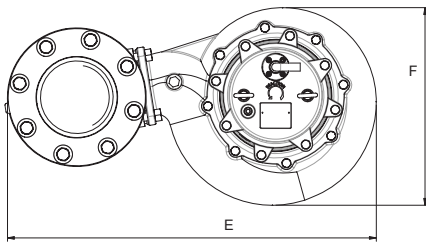

Dimensions	mm	in
A	838	33
B	758	29.8
C	437	17.2
D	270	10.6
E	752	29.6
F	403	15.9

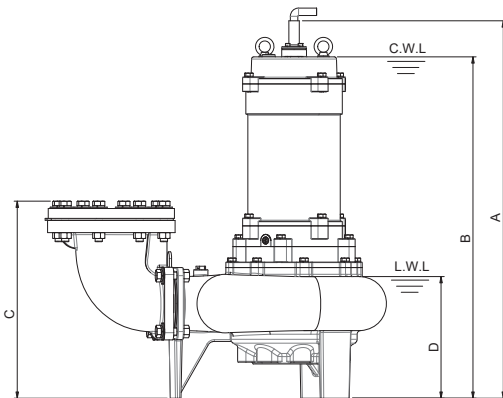

Weight : 138kg / 304 lbs

<input checked="" type="checkbox"/>	Simplex
<input type="checkbox"/>	Duplex
<input type="checkbox"/>	Triplex

<input checked="" type="checkbox"/>	OPTIONAL EQUIPMENT
<input type="checkbox"/>	Additional cable 30 □ 40 □ 50 □ 75 □ Ft.
<input type="checkbox"/>	Slide away coupling
<input type="checkbox"/>	Impeller trims
<input type="checkbox"/>	High Temp winding and seal liquids 190°F / 88°C

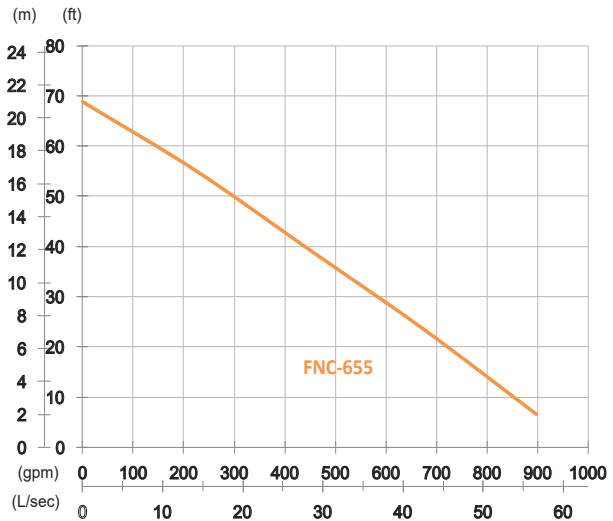

Shaft Speed : 1450 rpm

Outlet : 150mm, 6in

OUTPUT	HEAD	FLOW
5.5 kW	Rated : 12m, 39ft	Rated : 28.3 L/s, 449 gpm
7.5 HP	Max : 21m, 69ft	Max : 56.6 L/s, 898 gpm

Solid Passage : 76mm, 3in

Pump Type		Electric Submersible Pumps
		3-Phase
Motor	Type	Induction Motor
	Insulation	Class F
	Protector	Star-Delta • Miniature Thermal Sensors D.O.L. • Circle Thermal Protector
	Starter	Star-Delta , D.O.L.
Lubricant		Food Grade (ISO VG32)
Impeller Type		Single Channel
Shaft Seal		Double Mechanical Seal Silicon Carbide VS Ceramic / Carbon
Bearings		C3 Shielded ball bearings
Cable		PVC (CSA Certified) / H07RN-F 10m (33ft) or longer upon request.
Materials	Pump Casing	Gray Iron
	Impeller	Gray Iron
	Motor Frame	Gray Iron
	Motor Shaft	Stainless Steel
	Mouth Ring	Copper Alloy
Max. Liquid Temperature		40°C (104°F)
Max. Submersion Depth		20m (66ft)
pH Range		pH 5 - pH 8

#### FNC-475

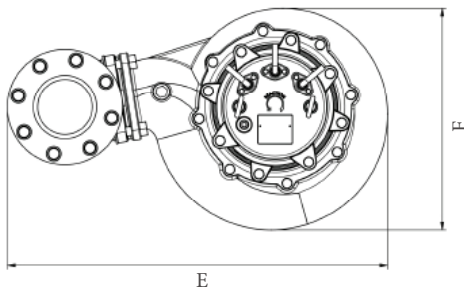

Dimensions	mm	in
A	838	33
B	758	29.8
C	364	14.3
D	270	10.6
E	693	27.3
F	403	15.9

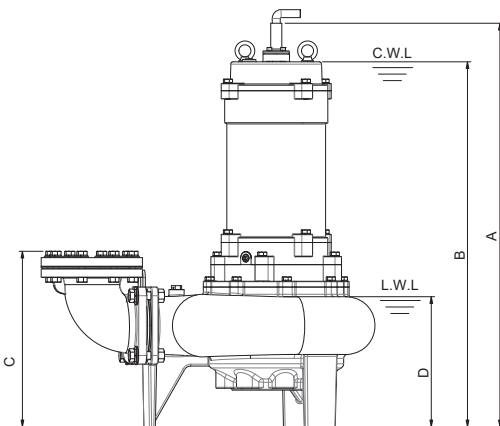

Weight : 142kg / 313 lbs

<input checked="" type="checkbox"/>	
<input type="checkbox"/>	Simplex
<input type="checkbox"/>	Duplex
<input type="checkbox"/>	Triplex

<input checked="" type="checkbox"/>	OPTIONAL EQUIPMENT
<input type="checkbox"/>	Additional cable 30 □ 40 □ 50 □ 75 □ Ft.
<input type="checkbox"/>	Slide away coupling
<input type="checkbox"/>	Impeller trims
<input type="checkbox"/>	High Temp winding and seal liquids 190°F / 88°C

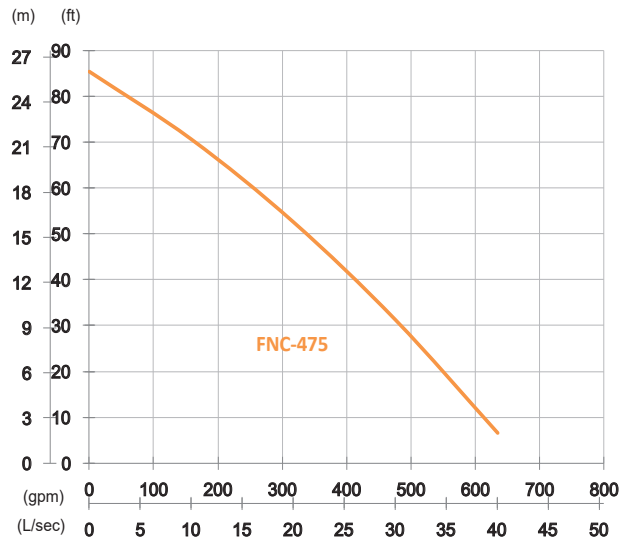

Shaft Speed : 1450 rpm

Outlet : 100mm, 4in

OUTPUT	HEAD	FLOW
7.5 kW	Rated : 16m, 52ft	Rated : 20 L/s, 317 gpm
10 HP	Max : 26m, 85ft	Max : 40 L/s, 634 gpm

Solid Passage : 76mm, 3in

Pump Type		Electric Submersible Pumps
		3-Phase
Motor	Type	Induction Motor
	Insulation	Class F
	Protector	Star-Delta • Miniature Thermal Sensors D.O.L. • Circle Thermal Protector
	Starter	Star-Delta , D.O.L.
Lubricant		Food Grade (ISO VG32)
Impeller Type		Single Channel
Shaft Seal		Double Mechanical Seal Silicon Carbide VS Ceramic / Carbon
Bearings		C3 Shielded ball bearings
Cable		PVC (CSA Certified) / H07RN-F 10m (33ft) or longer upon request.
Materials	Pump Casing	Gray Iron
	Impeller	Gray Iron
	Motor Frame	Gray Iron
	Motor Shaft	Stainless Steel
	Mouth Ring	Copper Alloy
Max. Liquid Temperature		40°C (104°F)
Max. Submersion Depth		20m (66ft)
pH Range		pH 5 - pH 8

#### FNC-675

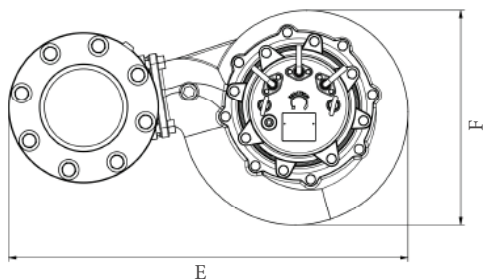

Dimensions	mm	in
A	838	33
B	758	29.8
C	437	17.2
D	270	10.6
E	752	29.6
F	403	15.9

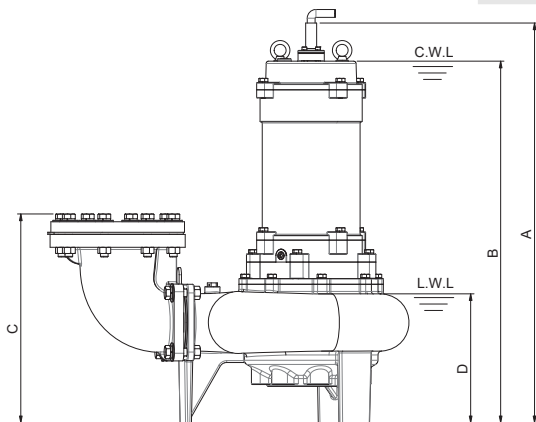

Weight : 148kg / 326 lbs

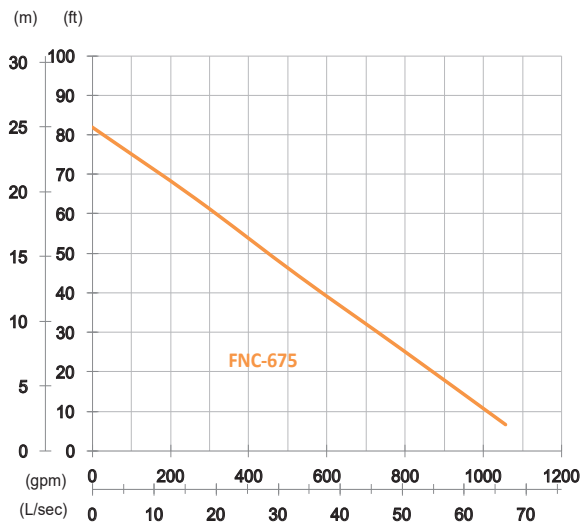

Shaft Speed : 1450 rpm

Outlet : 150mm, 6in

OUTPUT	HEAD	FLOW
7.5 kW	Rated : 13.5m, 44ft	Rated : 33.3 L/s, 528 gpm
10 HP	Max : 25m, 82ft	Max : 66.6 L/s, 1056 gpm
Solid Passage : 76mm, 3in		

Pump Type		Electric Submersible Pumps	
		3-Phase	
Motor	Type	Induction Motor	
	Insulation	Class F	
	Protector	Star-Delta • Miniature Thermal Sensors	
		D.O.L. • Circle Thermal Protector	
Starter	Star-Delta , D.O.L.		
Lubricant		Food Grade (ISO VG32)	
Impeller Type		Single Channel	
Shaft Seal		Double Mechanical Seal	
		Silicon Carbide VS Ceramic / Carbon	
Bearings		C3 Shielded ball bearings	
Cable		PVC (CSA Certified) / H07RN-F	
		10m (33ft) or longer upon request.	
Materials	Pump Casing	Gray Iron	
	Impeller	Gray Iron	
	Motor Frame	Gray Iron	
	Motor Shaft	Stainless Steel	
	Mouth Ring	Copper Alloy	
Max. Liquid Temperature		40°C (104°F)	
Max. Submersion Depth		20m (66ft)	
pH Range		pH 5 - pH 8	

<input checked="" type="checkbox"/>	Simplex
<input type="checkbox"/>	Duplex
<input type="checkbox"/>	Triplex

<input checked="" type="checkbox"/>	OPTIONAL EQUIPMENT
<input type="checkbox"/>	Additional cable 30 □ 40 □ 50 □ 75 □ Ft.
<input type="checkbox"/>	Slide away coupling
<input type="checkbox"/>	Impeller trims
<input type="checkbox"/>	High Temp winding and seal liquids 190°F / 88°C

FloFab is certified :





# SERIES FNC Single Channel Pump

SUBMITTAL DATA

50HZ

FNC-4110

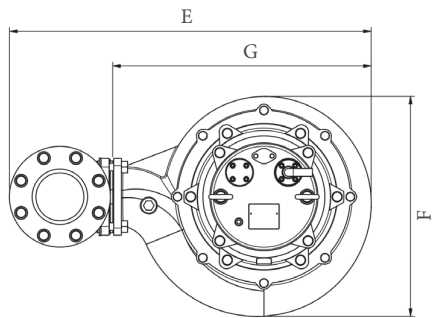
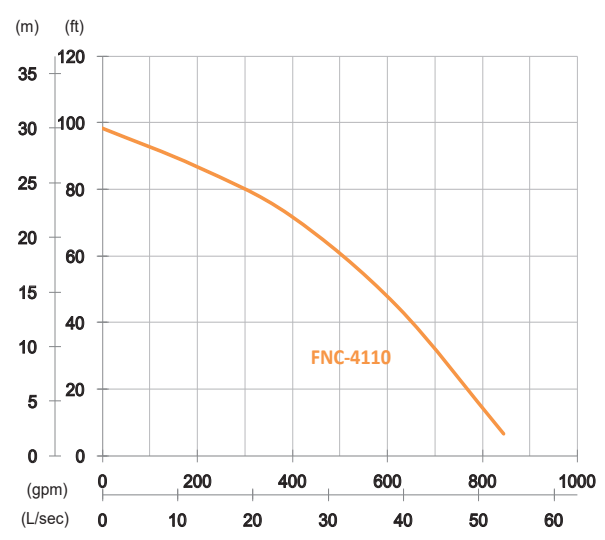

Dimensions	mm	in
A	830	32.7
B	750	29.5
C	379	14.9
D	276	10.9
E	753	29.6
F	459	18.1
G	538	21.2

Shaft Speed : 1450 rpm

Outlet : 100mm, 4in

OUTPUT	HEAD	FLOW
11 kW	Rated : 22m, 72ft	Rated : 25 L/s, 396 gpm
15 HP	Max : 30m, 98ft	Max : 53.3 L/s, 845 gpm

Solid Passage : 76mm, 3in

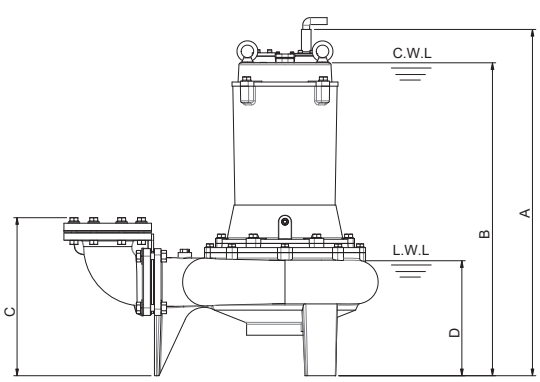

Weight : 167kg / 368 lbs

Pump Type		Electric Submersible Pumps
		3-Phase
Motor	Type	Induction Motor
	Insulation	Class F
	Protector	Star-Delta • Miniature Thermal Sensors D.O.L. • Circle Thermal Protector
	Starter	Star-Delta , D.O.L.
Lubricant		Food Grade (ISO VG32)
Impeller Type		Single Channel
Shaft Seal		Double Mechanical Seal Silicon Carbide VS Ceramic / Carbon
Bearings		C3 Shielded ball bearings
Cable		PVC (CSA Certified) / H07RN-F 10m (33ft) or longer upon request.
Materials	Pump Casing	Gray Iron
	Impeller	Gray Iron
	Motor Frame	Gray Iron
	Motor Shaft	Stainless Steel
	Mouth Ring	Copper Alloy
Max. Liquid Temperature		40°C (104°F)
Max. Submersion Depth		20m (66ft)
pH Range		pH 5 - pH 8

<input checked="" type="checkbox"/>	Simplex
<input type="checkbox"/>	Duplex
<input type="checkbox"/>	Triplex

<input checked="" type="checkbox"/>	OPTIONAL EQUIPMENT
<input type="checkbox"/>	Additional cable 30 □ 40 □ 50 □ 75 □ Ft.
<input type="checkbox"/>	Slide away coupling
<input type="checkbox"/>	Impeller trims
<input type="checkbox"/>	High Temp winding and seal liquids 190°F / 88°C



# SERIES FNC Single Channel Pump

SUBMITTAL DATA

50HZ

FNC-4150

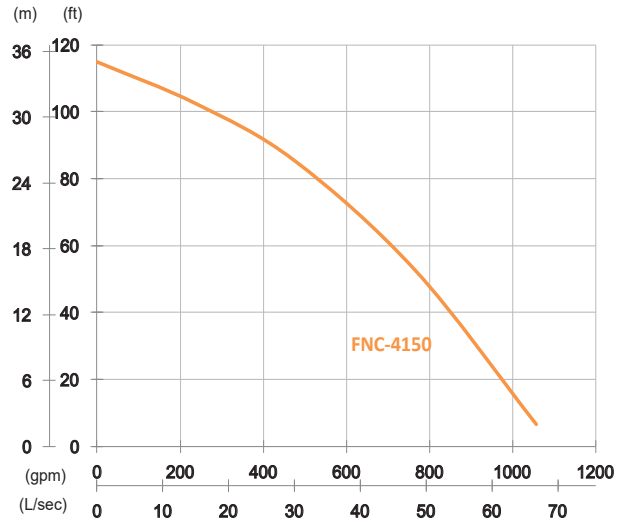

Shaft Speed : 1450 rpm

Outlet : 100mm, 4in

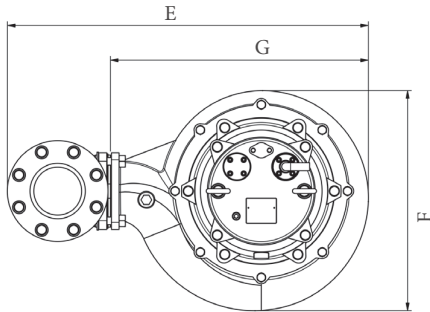

Dimensions	mm	in
A	830	32.7
B	750	29.5
C	379	14.9
D	276	10.9
E	753	29.6
F	459	18.1
G	538	21.2

OUTPUT	HEAD	FLOW
15 kW	Rated : 26m, 85ft	Rated : 30 L/s, 475 gpm
20 HP	Max : 35m, 115ft	Max : 66.6 L/s, 1056 gpm

Solid Passage : 76mm, 3in

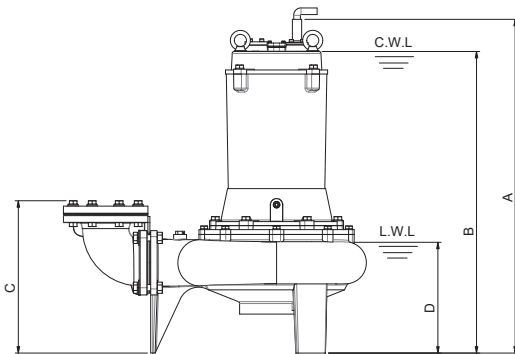

Weight : 178kg / 392 lbs

Pump Type		Electric Submersible Pumps
		3-Phase
Motor	Type	Induction Motor
	Insulation	Class F
	Protector	Star-Delta • Miniature Thermal Sensors D.O.L. • Circle Thermal Protector
	Starter	Star-Delta , D.O.L.
Lubricant		Food Grade (ISO VG32)
Impeller Type		Single Channel
Shaft Seal		Double Mechanical Seal Silicon Carbide VS Ceramic / Carbon
Bearings		C3 Shielded ball bearings
Cable		PVC (CSA Certified) / H07RN-F 10m (33ft) or longer upon request.
Materials	Pump Casing	Gray Iron
	Impeller	Gray Iron
	Motor Frame	Gray Iron
	Motor Shaft	Stainless Steel
	Mouth Ring	Copper Alloy
Max. Liquid Temperature		40°C (104°F)
Max. Submersion Depth		20m (66ft)
pH Range		pH 5 - pH 8

<input checked="" type="checkbox"/>	Simplex
<input type="checkbox"/>	Duplex
<input type="checkbox"/>	Triplex

<input checked="" type="checkbox"/>	OPTIONAL EQUIPMENT
<input type="checkbox"/>	Additional cable 30 □ 40 □ 50 □ 75 □ Ft.
<input type="checkbox"/>	Slide away coupling
<input type="checkbox"/>	Impeller trims
<input type="checkbox"/>	High Temp winding and seal liquids 190°F / 88°C





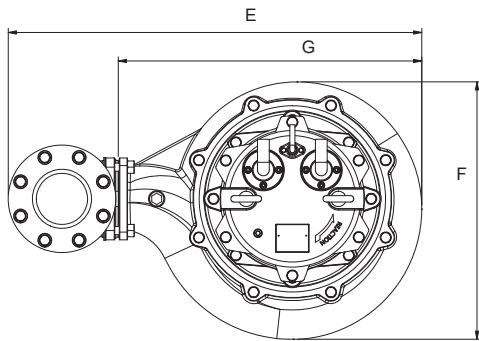

Dimensions	mm	in
A	1007	39.6
B	930	36.6
C	382	15
D	285	11.2
E	808	31.8
F	503	19.8
G	593	23.3

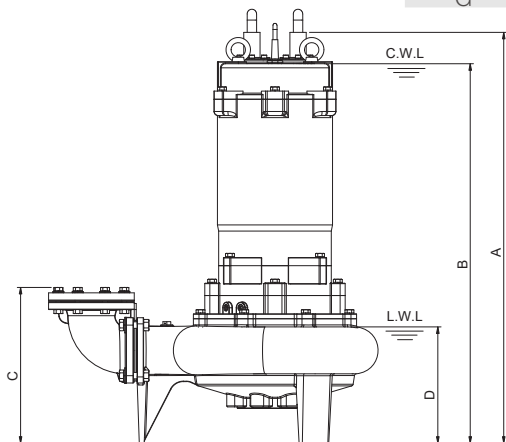

Weight : 256kg / 564 lbs

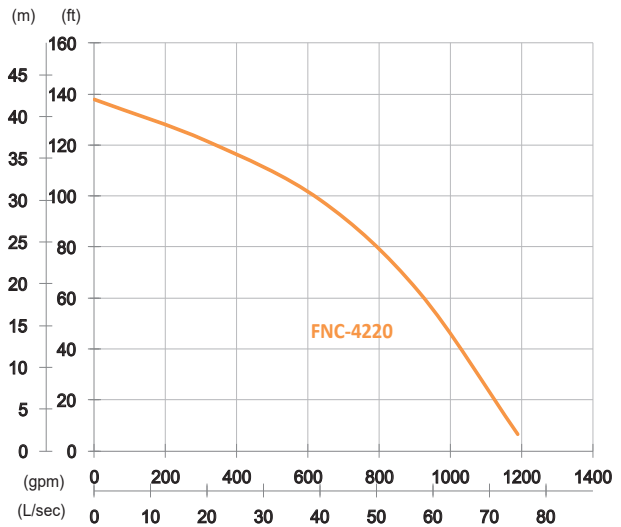

Shaft Speed : 1450 rpm

Outlet : 100mm, 4in

OUTPUT	HEAD	FLOW
22 kW	Rated : 30m, 98ft	Rated : 40 L/s, 634 gpm
30 HP	Max : 42m, 138ft	Max : 75 L/s, 1188 gpm

Solid Passage : 76mm, 3in

Pump Type	Electric Submersible Pumps	
	3-Phase	
Motor	Type	Induction Motor
	Insulation	Class F
	Protector	Miniature Thermal Sensors
	Starter	Star-Delta
Lubricant	Food Grade (ISO VG32)	
Impeller Type	Single Channel	
Shaft Seal	Double Mechanical Seal	
	Silicon Carbide VS Ceramic / Carbon	
Bearings	C3 Shielded ball bearings	
Cable	PVC (CSA Certified) / H07RN-F	
	10m (33ft) or longer upon request.	
Materials	Pump Casing	Gray Iron
	Impeller	Gray Iron
	Motor Frame	Gray Iron
	Motor Shaft	Stainless Steel
	Mouth Ring	Copper Alloy
Max. Liquid Temperature	40°C (104°F)	
Max. Submersion Depth	20m (66ft)	
pH Range	pH 5 - pH 8	

<input checked="" type="checkbox"/>	Simplex
<input type="checkbox"/>	Duplex
<input type="checkbox"/>	Triplex

<input checked="" type="checkbox"/>	OPTIONAL EQUIPMENT
<input type="checkbox"/>	Additional cable 30 □ 40 □ 50 □ 75 □ Ft.
<input type="checkbox"/>	Slide away coupling
<input type="checkbox"/>	Impeller trims
<input type="checkbox"/>	High Temp winding and seal liquids 190°F / 88°C

FloFab is certified :



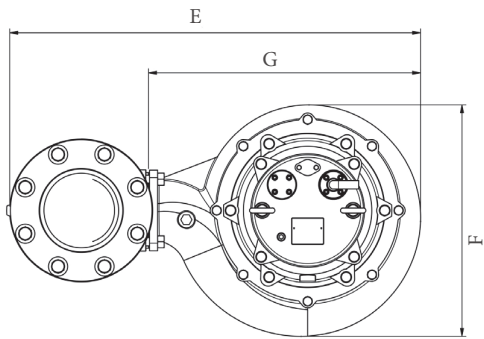
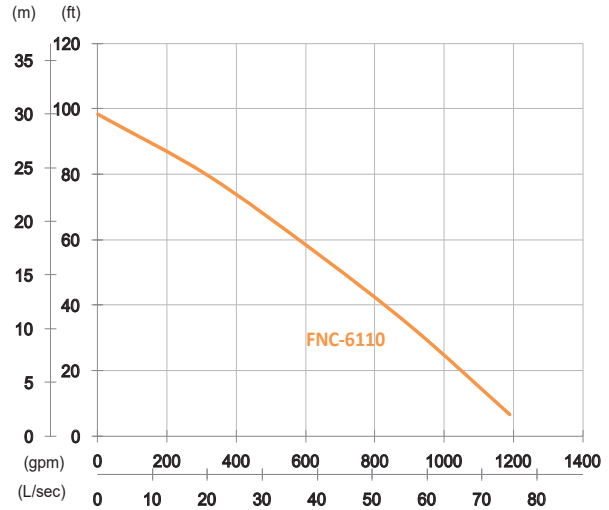

Dimensions	mm	in
A	830	32.7
B	750	29.5
C	452	17.8
D	276	10.9
E	813	32
F	459	18.1
G	538	21.2

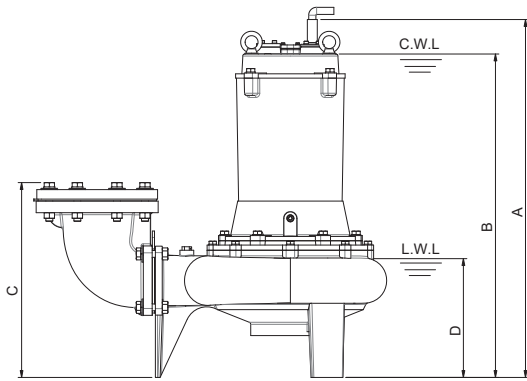

Weight : 175kg / 386 lbs

Shaft Speed : 1450 rpm

Outlet : 150mm, 6in

OUTPUT	HEAD	FLOW
11 kW	Rated : 17m, 56ft	Rated : 40 L/s, 634 gpm
15 HP	Max : 30m, 98ft	Max : 75 L/s, 1188 gpm

Solid Passage : 76mm, 3in

Pump Type	Electric Submersible Pumps	
	3-Phase	
Motor	Type	Induction Motor
	Insulation	Class F
	Protector	Star-Delta • Miniature Thermal Sensors D.O.L. • Circle Thermal Protector
	Starter	Star-Delta , D.O.L.
Lubricant	Food Grade (ISO VG32)	
Impeller Type	Single Channel	
Shaft Seal	Double Mechanical Seal	
	Silicon Carbide VS Ceramic / Carbon	
Bearings	C3 Shielded ball bearings	
Cable	PVC (CSA Certified) / H07RN-F	
	10m (33ft) or longer upon request.	
Materials	Pump Casing	Gray Iron
	Impeller	Gray Iron
	Motor Frame	Gray Iron
	Motor Shaft	Stainless Steel
	Mouth Ring	Copper Alloy
Max. Liquid Temperature	40°C (104°F)	
Max. Submersion Depth	20m (66ft)	
pH Range	pH 5 - pH 8	

<input checked="" type="checkbox"/>	Simplex
<input type="checkbox"/>	Duplex
<input type="checkbox"/>	Triplex

<input checked="" type="checkbox"/>	OPTIONAL EQUIPMENT
<input type="checkbox"/>	Additional cable 30 □ 40 □ 50 □ 75 □ Ft.
<input type="checkbox"/>	Slide away coupling
<input type="checkbox"/>	Impeller trims
<input type="checkbox"/>	High Temp winding and seal liquids 190°F / 88°C

FloFab is certified :



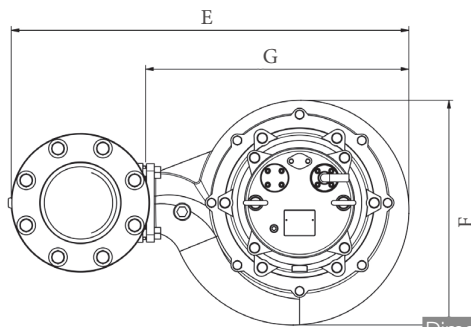

Dimensions	mm	in
A	830	32.7
B	750	29.5
C	452	17.8
D	276	10.9
E	813	32
F	459	18.1
G	538	21.2

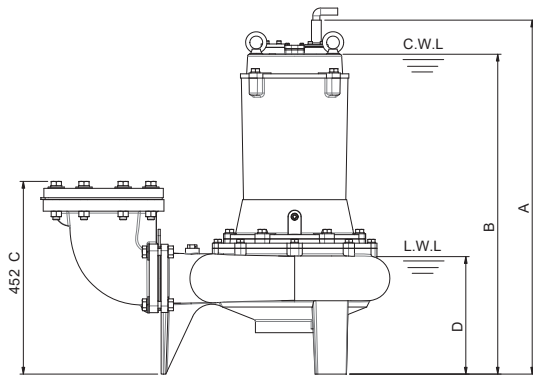

Weight : 186kg / 410 lbs

<input checked="" type="checkbox"/>	Simplex
<input type="checkbox"/>	Duplex
<input type="checkbox"/>	Triplex

<input checked="" type="checkbox"/>	OPTIONAL EQUIPMENT
<input type="checkbox"/>	Additional cable 30 □ 40 □ 50 □ 75 □ Ft.
<input type="checkbox"/>	Slide away coupling
<input type="checkbox"/>	Impeller trims
<input type="checkbox"/>	High Temp winding and seal liquids 190°F / 88°C

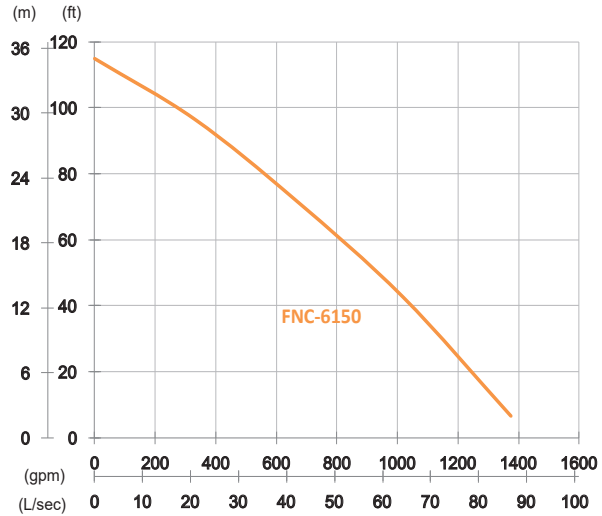

Shaft Speed : 1450 rpm

Outlet : 150mm, 6in

OUTPUT	HEAD	FLOW
15 kW	Rated : 22m, 72ft	Rated : 41.6 L/s, 660 gpm
20 HP	Max : 35m, 115ft	Max : 86.6 L/s, 1373 gpm

Solid Passage : 76mm, 3in

Pump Type		Electric Submersible Pumps
		3-Phase
Motor	Type	Induction Motor
	Insulation	Class F
	Protector	Star-Delta • Miniature Thermal Sensors D.O.L. • Circle Thermal Protector
	Starter	Star-Delta , D.O.L.
Lubricant		Food Grade (ISO VG32)
Impeller Type		Single Channel
Shaft Seal		Double Mechanical Seal Silicon Carbide VS Ceramic / Carbon
Bearings		C3 Shielded ball bearings
Cable		PVC (CSA Certified) / H07RN-F 10m (33ft) or longer upon request.
Materials	Pump Casing	Gray Iron
	Impeller	Gray Iron
	Motor Frame	Gray Iron
	Motor Shaft	Stainless Steel
	Mouth Ring	Copper Alloy
Max. Liquid Temperature		40°C (104°F)
Max. Submersion Depth		20m (66ft)
pH Range		pH 5 - pH 8

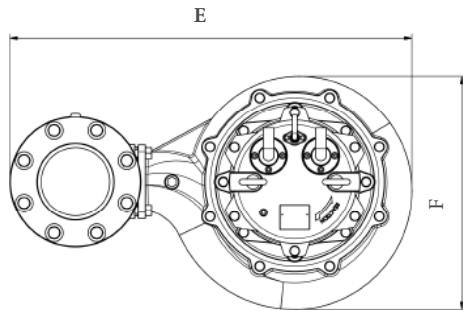
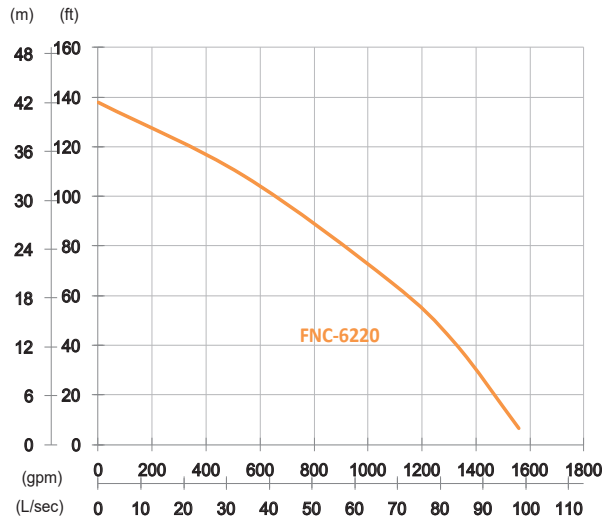

Dimensions	mm	in
A	1007	39.6
B	930	36.6
C	455	17.9
D	285	11.2
E	867	34.1
F	503	19.8

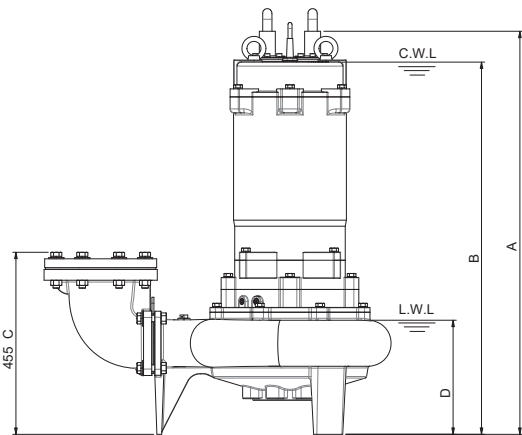

Weight : 262kg / 578 lbs

Shaft Speed : 1450 rpm

Outlet : 150mm, 6in

OUTPUT	HEAD	FLOW
22 kW	Rated : 20m, 66ft	Rated : 68.3 L/s, 1082 gpm
30 HP	Max : 42m, 138ft	Max : 98.3 L/s, 1558 gpm

Solid Passage : 76mm, 3in

Pump Type		Electric Submersible Pumps
		3-Phase
Motor	Type	Induction Motor
	Insulation	Class F
	Protector	Miniature Thermal Sensors
	Starter	Star-Delta
Lubricant		Food Grade (ISO VG32)
Impeller Type		Single Channel
Shaft Seal		Double Mechanical Seal Silicon Carbide VS Ceramic / Carbon
Bearings		C3 Shielded ball bearings
Cable		PVC (CSA Certified) / H07RN-F 10m (33ft) or longer upon request.
Materials	Pump Casing	Gray Iron
	Impeller	Gray Iron
	Motor Frame	Gray Iron
	Motor Shaft	Stainless Steel
	Mouth Ring	Copper Alloy
Max. Liquid Temperature		40°C (104°F)
Max. Submersion Depth		20m (66ft)
pH Range		pH 5 - pH 8

<input checked="" type="checkbox"/>	Simplex
<input type="checkbox"/>	Duplex
<input type="checkbox"/>	Triplex

<input checked="" type="checkbox"/>	OPTIONAL EQUIPMENT
<input type="checkbox"/>	Additional cable 30 □ 40 □ 50 □ 75 □ Ft.
<input type="checkbox"/>	Slide away coupling
<input type="checkbox"/>	Impeller trims
<input type="checkbox"/>	High Temp winding and seal liquids 190°F / 88°C

FloFab is certified :



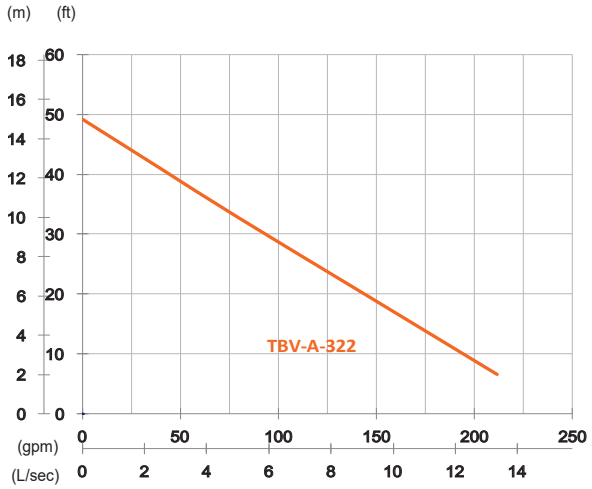

Shaft Speed : 2850 rpm

Outlet : 80mm, 3in

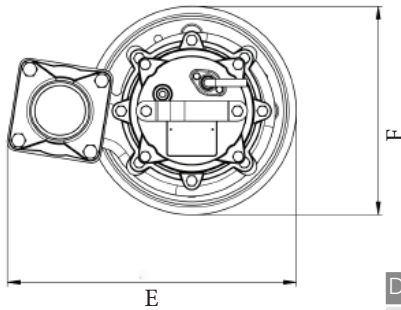

Dimensions	mm	in
A	665	26.2
B	536	21.1
C		
D	155	6.1
E	373	14.7
F	270	10.6

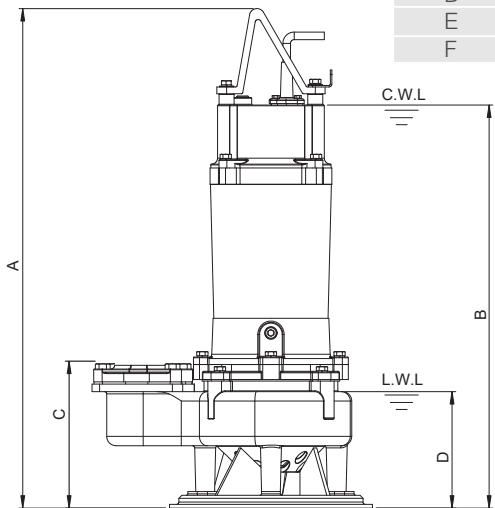

Weight : 43kg / 95 lbs

OUTPUT	HEAD	FLOW
2.2 kW	Rated : 10m, 33ft	Rated : 5 L/s, 79 gpm
3 HP	Max : 15m, 49ft	Max : 13.3 L/s, 211 gpm

Solid Passage : 13mm, 0.5in

Pump Type		Electric Submersible Pumps
		3-Phase
Motor	Type	Induction Motor
	Insulation	Class F
	Protector	Circle Thermal Protector
	Starter	D.O.L.
Lubricant		Food Grade (ISO VG32)
Impeller Type		Vortex
Shaft Seal	Double Mechanical Seal	
	Silicon Carbide VS Ceramic / Carbon	
Bearings		C3 Shielded ball bearings
Cable	PVC (CSA Certified) / H07RN-F	
	10m (33ft) or longer upon request.	
Materials	Pump Casing	Ductile Iron
	Impeller	Gray Iron
	Motor Frame	Gray Iron
	Motor Shaft	Stainless Steel
Agitator		Ductile Iron
Max. Liquid Temperature		40°C (104°F)
Max. Submersion Depth		20m (66ft)
pH Range		pH 5 - pH 8

<input checked="" type="checkbox"/>	
<input type="checkbox"/>	Simplex
<input type="checkbox"/>	Duplex
<input type="checkbox"/>	Triplex

<input checked="" type="checkbox"/>	OPTIONAL EQUIPMENT
<input type="checkbox"/>	Additional cable 30 □ 40 □ 50 □ 75 □ Ft.
<input type="checkbox"/>	Slide away coupling
<input type="checkbox"/>	Impeller trims
<input type="checkbox"/>	High Temp winding and seal liquids 190°F / 88°C

FloFab is certified :





# SERIES TBV-A Vortex Pump with Agitator TBV-A-337

SUBMITTAL DATA

50HZ

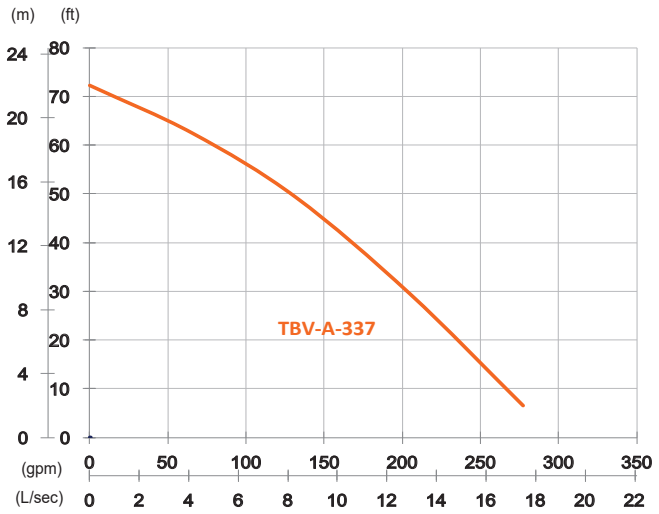

Shaft Speed : 2850 rpm

Outlet : 80mm, 3in

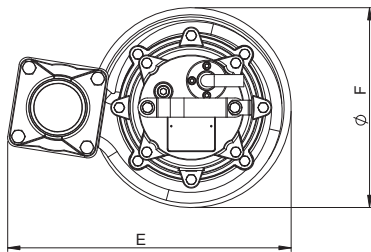

Dimensions	mm	in
A	718	28.3
B	590	23.2
C		
D	160	6.3
E	383	15.1
F	270	10.6

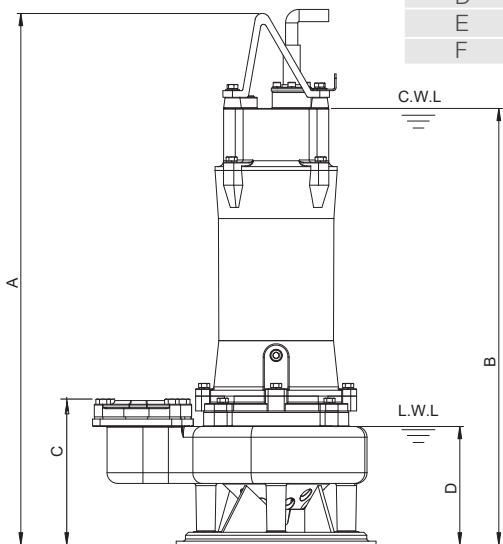

Weight : 53kg / 117 lbs

OUTPUT	HEAD	FLOW
3.7 kW	Rated : 15m, 49ft	Rated : 8.3 L/s, 132 gpm
5 HP	Max : 22m, 72ft	Max : 17.5 L/s, 277 gpm

Solid Passage : 13mm, 0.5in

Pump Type		Electric Submersible Pumps
		3-Phase
Motor	Type	Induction Motor
	Insulation	Class F
	Protector	Circle Thermal Protector
	Starter	D.O.L.
Lubricant		Food Grade (ISO VG32)
Impeller Type		Vortex
Shaft Seal		Double Mechanical Seal
		Silicon Carbide VS Ceramic / Carbon
Bearings		C3 Shielded ball bearings
Cable		PVC (CSA Certified) / H07RN-F
		10m (33ft) or longer upon request.
Materials	Pump Casing	Ductile Iron
	Impeller	Gray Iron
	Motor Frame	Gray Iron
	Motor Shaft	Stainless Steel
Agitator		Ductile Iron
Max. Liquid Temperature		40°C (104°F)
Max. Submersion Depth		20m (66ft)
pH Range		pH 5 - pH 8

<input checked="" type="checkbox"/>	Simplex
<input type="checkbox"/>	Duplex
<input type="checkbox"/>	Triplex

<input checked="" type="checkbox"/>	OPTIONAL EQUIPMENT
<input type="checkbox"/>	Additional cable 30 □ 40 □ 50 □ 75 □ Ft.
<input type="checkbox"/>	Slide away coupling
<input type="checkbox"/>	Impeller trims
<input type="checkbox"/>	High Temp winding and seal liquids 190°F / 88°C

FloFab is certified :   

#### FS-400

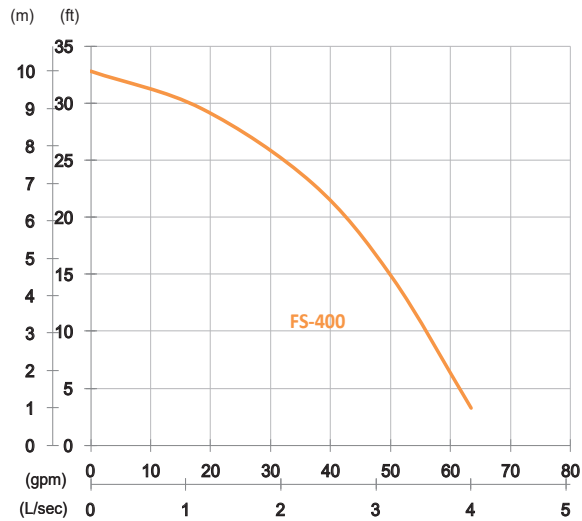

Shaft Speed : 2850 rpm

Outlet : 50mm, 2in

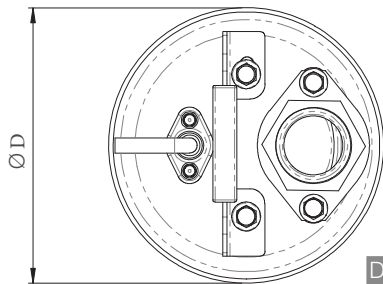

Dimensions	mm	in
A		
B	247	9.7
C	52	2
D	184	7.2

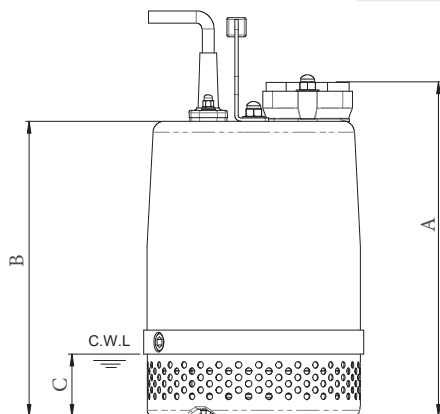

Weight : 13kg / 29 lbs

OUTPUT	HEAD	FLOW
0.4 kW	Rated : 7m, 23ft	Rated : 2.3 L/s, 37 gpm
0.5 HP	Max : 10m, 33ft	Max : 4 L/s, 63 gpm

Solid Passage : 5.5mm, 0.2in

Pump Type		Electric Submersible Pumps
		1-Phase, 3-Phase
Motor	Type	Induction Motor
	Insulation	Class F
	Protector	Circle Thermal Protector
	Starter	1-Phase • Capacitor-Run, 3-Phase • D.O.L
Lubricant		Food Grade (ISO VG32)
Impeller Type		Opened
Shaft Seal		Double Mechanical Seal
		Silicon Carbide VS Ceramic / Carbon
Bearings		C3 Shielded ball bearings
Cable		PVC (CSA Certified) / H07RN-F
		6m (20ft) or longer upon request.
Materials	Pump Casing	Gray Iron
	Impeller	Gray Iron
	Motor Frame	Stainless Steel
	Motor Shaft	Stainless Steel
	Outer Case	Stainless Steel
	Strainer	Stainless Steel
Max. Liquid Temperature		40°C (104°F)
Max. Submersion Depth		20m (66ft)
pH Range		pH 5 - pH 8

<input checked="" type="checkbox"/>	Simplex
<input type="checkbox"/>	Duplex
<input type="checkbox"/>	Triplex

<input checked="" type="checkbox"/>	OPTIONAL EQUIPMENT
<input type="checkbox"/>	Additional cable 30 □ 40 □ 50 □ 75 □ Ft.
<input type="checkbox"/>	Slide away coupling
<input type="checkbox"/>	Impeller trims
<input type="checkbox"/>	High Temp winding and seal liquids 190°F / 88°C

#### FS-750

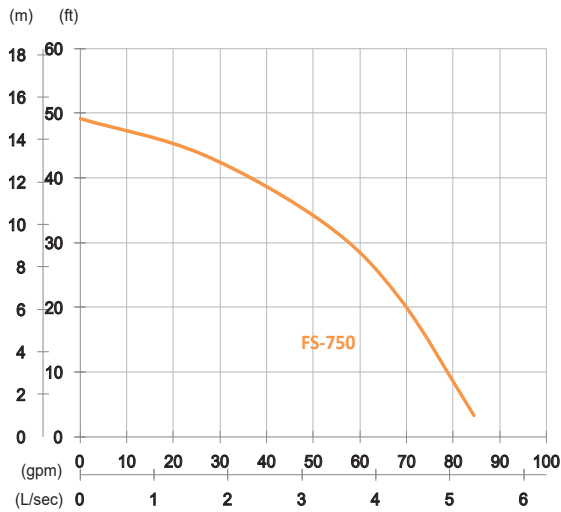

Shaft Speed : 2850 rpm

Outlet : 50mm, 2in

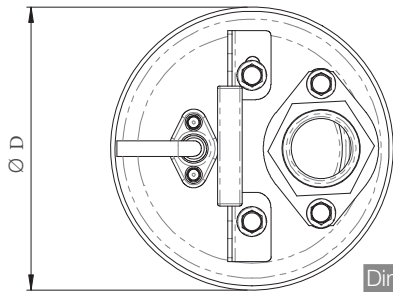

Dimensions	mm	in
A		
B	274	10.8
C	52	2
D	184	7.2

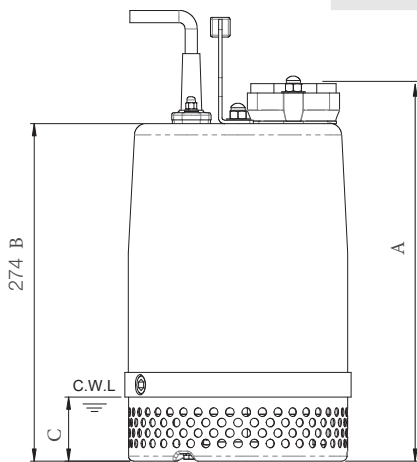

Weight : 14kg / 31 lbs

OUTPUT	HEAD	FLOW
0.75 kW	Rated : 10m, 33ft	Rated : 3.3 L/s, 53 gpm
1 HP	Max : 15m, 49ft	Max : 5.3 L/s, 84 gpm

Solid Passage : 7mm, 0.3in

Pump Type		Electric Submersible Pumps
		1-Phase, 3-Phase
Motor	Type	Induction Motor
	Insulation	Class F
	Protector	Circle Thermal Protector
	Starter	1-Phase • Capacitor-Run, 3-Phase • D.O.L
Lubricant		Food Grade (ISO VG32)
Impeller Type		Opened
Shaft Seal		Double Mechanical Seal Silicon Carbide VS Ceramic / Carbon
Bearings		C3 Shielded ball bearings
Cable		PVC (CSA Certified) / H07RN-F 6m (20ft) or longer upon request.
Materials	Pump Casing	Gray Iron
	Impeller	Gray Iron
	Motor Frame	Stainless Steel
	Motor Shaft	Stainless Steel
	Outer Case	Stainless Steel
	Strainer	Stainless Steel
Max. Liquid Temperature		40°C (104°F)
Max. Submersion Depth		20m (66ft)
pH Range		pH 5 - pH 8

<input checked="" type="checkbox"/>	Simplex
<input type="checkbox"/>	Duplex
<input type="checkbox"/>	Triplex

<input checked="" type="checkbox"/>	OPTIONAL EQUIPMENT
<input type="checkbox"/>	Additional cable 30 □ 40 □ 50 □ 75 □ Ft.
<input type="checkbox"/>	Slide away coupling
<input type="checkbox"/>	Impeller trims
<input type="checkbox"/>	High Temp winding and seal liquids 190°F / 88°C



#### FS-1500

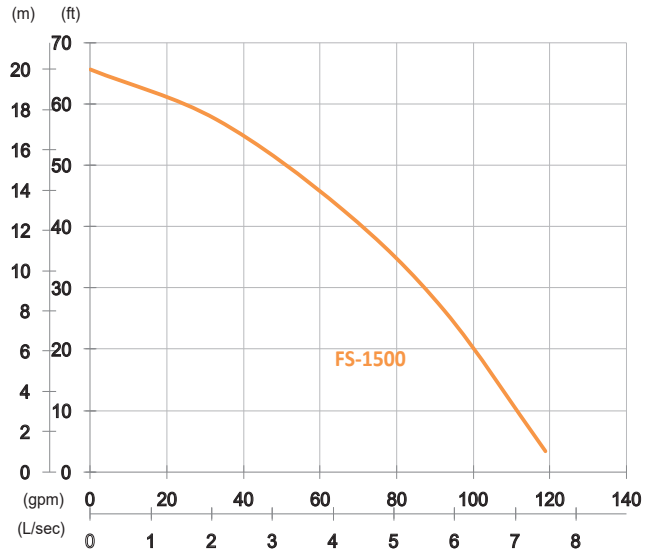

Shaft Speed : 2850 rpm

Outlet : 50mm, 2in

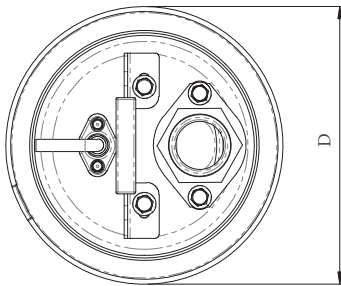

Dimensions	mm	in
A	433	17
B	347	13.7
C	71	2.8
D	225	8.9

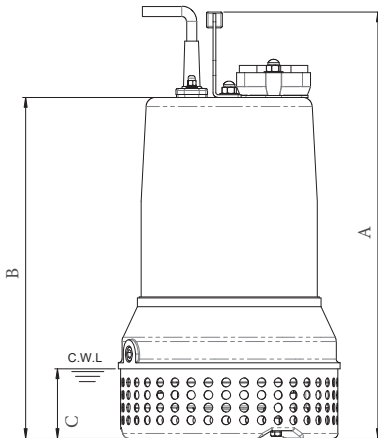

Weight : 24kg / 53 lbs

OUTPUT	HEAD	FLOW
1.5 kW	Rated : 13m, 43ft	Rated : 4.2 L/s, 66 gpm
2 HP	Max : 20m, 66ft	Max : 7.5 L/s, 119 gpm

Solid Passage : 9 mm, 0.4in

Pump Type		Electric Submersible Pumps
		1-Phase, 3-Phase
Motor	Type	Induction Motor
	Insulation	Class F
	Protector	Circle Thermal Protector
	Starter	1-Phase • Capacitor-Run, 3-Phase • D.O.L
Lubricant		Food Grade (ISO VG32)
Impeller Type		Opened
Shaft Seal		Double Mechanical Seal Silicon Carbide VS Ceramic / Carbon
Bearings		C3 Shielded ball bearings
Cable		PVC (CSA Certified) / H07RN-F 10m (33ft) or longer upon request.
Materials	Pump Casing	Gray Iron
	Impeller	Gray Iron
	Motor Frame	Stainless Steel
	Motor Shaft	Stainless Steel
	Outer Case	Stainless Steel
Strainer		Stainless Steel
Max. Liquid Temperature		40°C (104°F)
Max. Submersion Depth		20m (66ft)
pH Range		pH 5 - pH 8

<input checked="" type="checkbox"/>	
<input type="checkbox"/>	Simplex
<input type="checkbox"/>	Duplex
<input type="checkbox"/>	Triplex

<input checked="" type="checkbox"/>	OPTIONAL EQUIPMENT
<input type="checkbox"/>	Additional cable 30 □ 40 □ 50 □ 75 □ Ft.
<input type="checkbox"/>	Slide away coupling
<input type="checkbox"/>	Impeller trims
<input type="checkbox"/>	High Temp winding and seal liquids 190°F / 88°C

**FS-215**

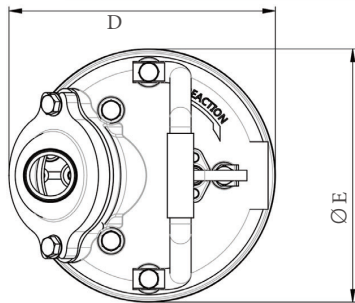
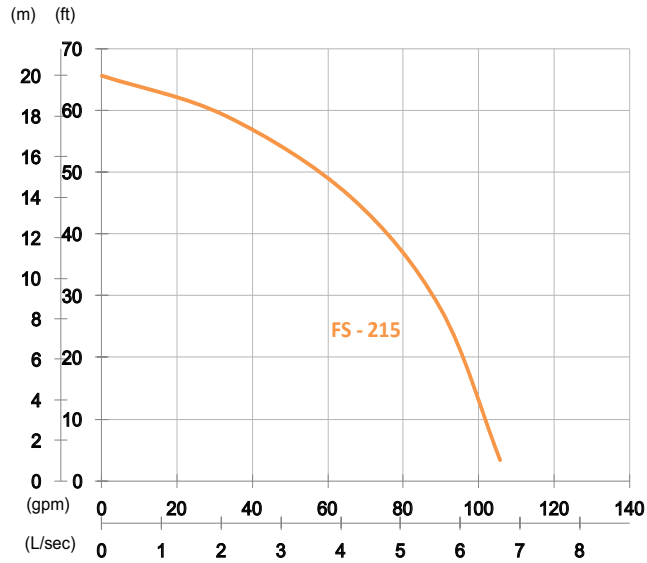

Dimensions	mm	in
A	568	22.4
B		
C	80	3.1
D	253	10
E	240	9.4

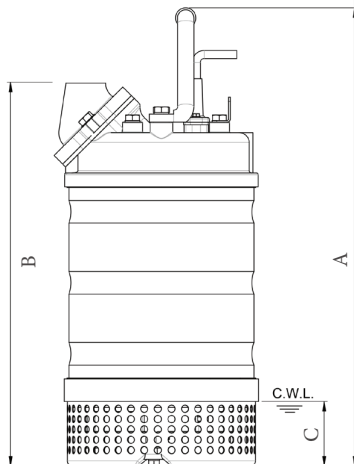

Weight : 33kg / 73 lbs

Shaft Speed : 2850 rpm

Outlet : 50mm, 2in

OUTPUT	HEAD	FLOW
1.5 kW	Rated : 14m, 46ft	Rated : 4.2 L/s, 66 gpm
2 HP	Max : 20m, 66ft	Max : 6.7 L/s, 105 gpm

Solid Passage : 9 mm, 0.4 in

Pump Type		Electric Submersible Pumps
		3-Phase
Motor	Type	Induction Motor
	Insulation	Class F
	Protector	Circle Thermal Protector
	Starter	3-Phase • D.O.L.
Lubricant		Food Grade (ISO VG32)
Impeller Type		Opened
Shaft Seal		Double Mechanical Seal
		Silicon Carbide VS Ceramic / Carbon
Bearings		C3 Shielded ball bearings
Cable		PVC (CSA Certified) / H07BQ-F
		10m (33ft) or longer upon request.
Materials	Pump Casing	Gray Iron
	Impeller	Chromium Iron
	Motor Frame	Stainless Steel
	Motor Shaft	Stainless Steel
	Strainer	Stainless Steel
Max. Liquid Temperature		40°C (104°F)
Max. Submersion Depth		20m (66ft)
pH Range		pH 5 - pH 8

<input checked="" type="checkbox"/>	Simplex
<input type="checkbox"/>	Duplex
<input type="checkbox"/>	Triplex

<input checked="" type="checkbox"/>	OPTIONAL EQUIPMENT
<input type="checkbox"/>	Additional cable 30 □ 40 □ 50 □ 75 □ Ft.
<input type="checkbox"/>	Slide away coupling
<input type="checkbox"/>	Impeller trims
<input type="checkbox"/>	High Temp winding and seal liquids 190°F / 88°C



# SERIES FS Dewatering Pump

SUBMITTAL DATA

50HZ

FS-315

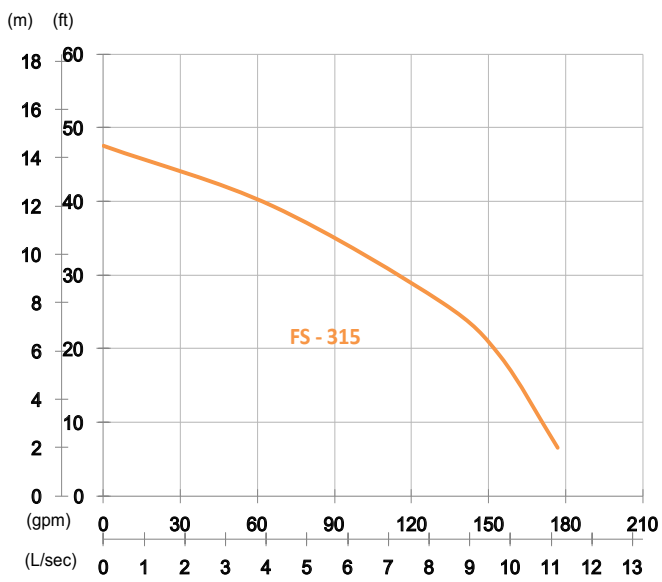

Shaft Speed : 2850 rpm Outlet : 80mm, 3in

OUTPUT	HEAD	FLOW
1.5 kW	Rated : 8m, 26ft	Rated : 8.3 L/s, 132 gpm
2 HP	Max : 14.5m, 48ft	Max : 11.2 L/s, 177 gpm

Solid Passage : 9 mm, 0.4 in

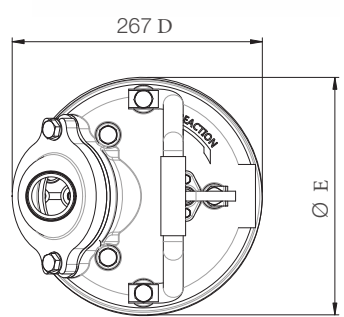

Dimensions	mm	in
A	568	22.4
B		
C	80	3.1
D	267	10.5
E	240	9.4

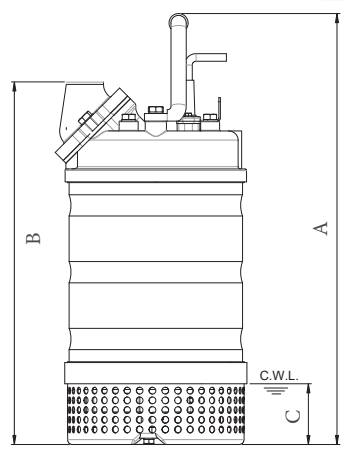

Weight : 33kg / 73 lbs

Pump Type		Electric Submersible Pumps
		3-Phase
Motor	Type	Induction Motor
	Insulation	Class F
	Protector	Circle Thermal Protector
	Starter	3-Phase • D.O.L.
Lubricant		Food Grade (ISO VG32)
Impeller Type		Opened
Shaft Seal		Double Mechanical Seal Silicon Carbide VS Ceramic / Carbon
Bearings		C3 Shielded ball bearings
Cable		PVC (CSA Certified) / H07BQ-F 10m (33ft) or longer upon request.
Materials	Pump Casing	Gray Iron
	Impeller	Chromium Iron
	Motor Frame	Stainless Steel
	Motor Shaft	Stainless Steel
	Strainer	Stainless Steel
Max. Liquid Temperature		40°C (104°F)
Max. Submersion Depth		20m (66ft)
pH Range		pH 5 - pH 8

<input checked="" type="checkbox"/>	Simplex
<input type="checkbox"/>	Duplex
<input type="checkbox"/>	Triplex

<input checked="" type="checkbox"/>	OPTIONAL EQUIPMENT
<input type="checkbox"/>	Additional cable 30 □ 40 □ 50 □ 75 □ Ft.
<input type="checkbox"/>	Slide away coupling
<input type="checkbox"/>	Impeller trims
<input type="checkbox"/>	High Temp winding and seal liquids 190°F / 88°C





# SERIES FS Dewatering Pump

SUBMITTAL DATA

50HZ

FS-222

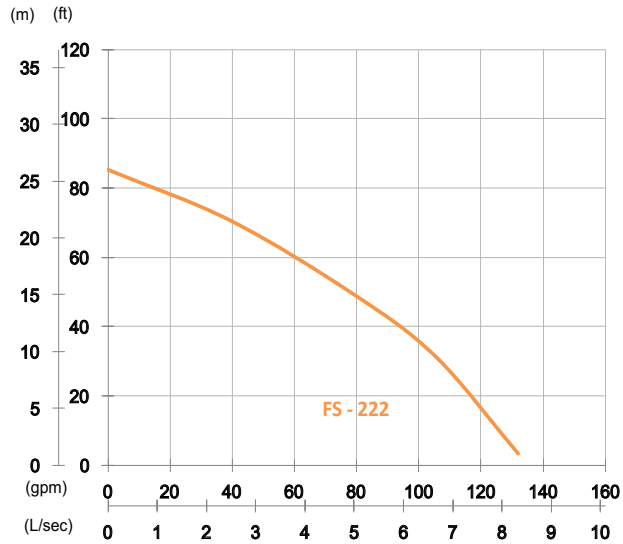

Shaft Speed : 2850 rpm

Outlet : 50mm, 2in

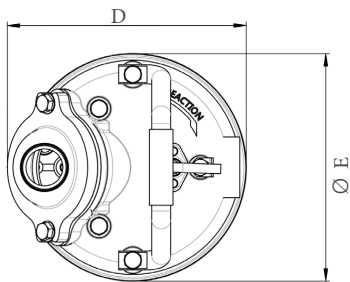

Dimensions	mm	in
A	598	23.5
B		
C	80	3.1
D	253	10
E	240	9.4

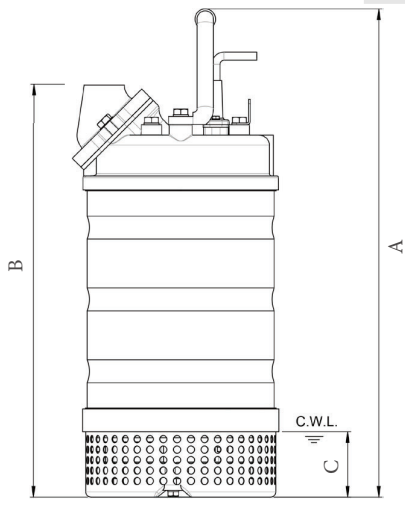

Weight : 35kg / 77 lbs

OUTPUT	HEAD	FLOW
2.2 kW	Rated : 15m, 49ft	Rated : 5 L/s, 79 gpm
3 HP	Max : 26m, 85ft	Max : 8.3 L/s, 132 gpm

Solid Passage : 9 mm, 0.4 in

Pump Type		Electric Submersible Pumps
		3-Phase
Motor	Type	Induction Motor
	Insulation	Class F
	Protector	Circle Thermal Protector
	Starter	D.O.L.
Lubricant		Food Grade (ISO VG32)
Impeller Type		Opened
Shaft Seal		Double Mechanical Seal
		Silicon Carbide VS Ceramic / Carbon
Bearings		C3 Shielded ball bearings
Cable		PVC (CSA Certified) / H07BQ-F
		10m (33ft) or longer upon request.
Materials	Pump Casing	Gray Iron
	Impeller	Chromium Iron
	Motor Frame	Stainless Steel
	Motor Shaft	Stainless Steel
	Strainer	Stainless Steel
Max. Liquid Temperature		40°C (104°F)
Max. Submersion Depth		20m (66ft)
pH Range		pH 5 - pH 8

<input checked="" type="checkbox"/>	
<input type="checkbox"/>	Simplex
<input type="checkbox"/>	Duplex
<input type="checkbox"/>	Triplex

<input checked="" type="checkbox"/>	OPTIONAL EQUIPMENT
<input type="checkbox"/>	Additional cable 30 □ 40 □ 50 □ 75 □ Ft.
<input type="checkbox"/>	Slide away coupling
<input type="checkbox"/>	Impeller trims
<input type="checkbox"/>	High Temp winding and seal liquids 190°F / 88°C

FloFab is certified :

FS-322

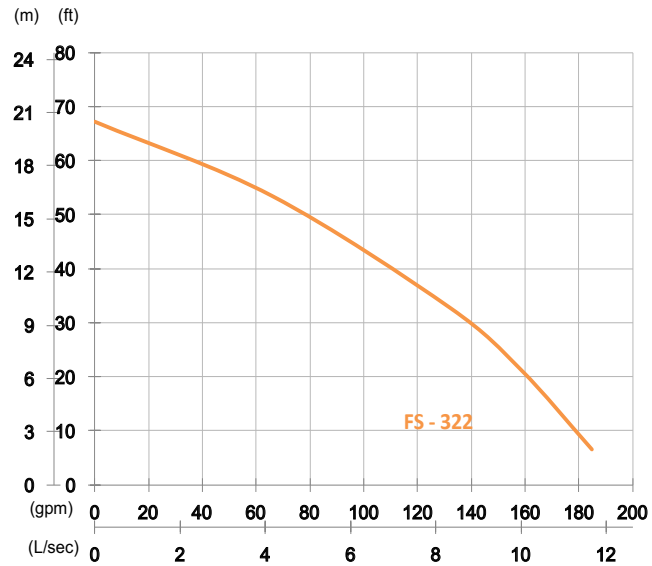

Shaft Speed : 2850 rpm

Outlet : 80mm, 3in

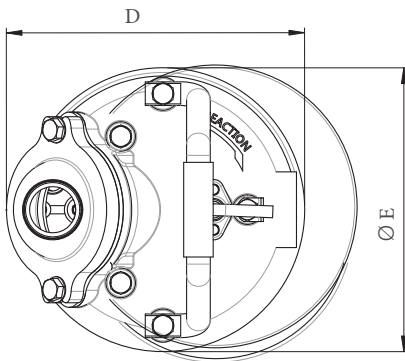

Dimensions	mm	in
A	598	23.5
B		
C	80	3.1
D	267	10.5
E	240	9.4

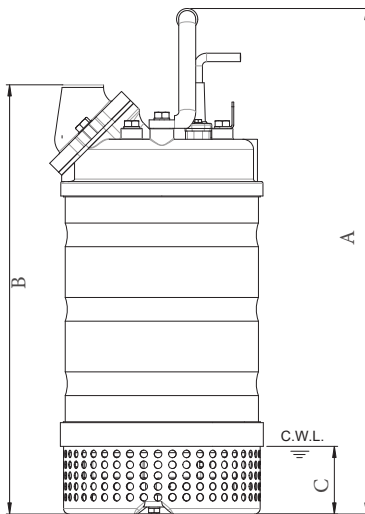

Weight : 35kg / 77 lbs

OUTPUT	HEAD	FLOW
2.2 kW	Rated : 10m, 33ft	Rated : 8.3 L/s, 132 gpm
3 HP	Max : 20.5m, 67ft	Max : 11.7 L/s, 185 gpm

Solid Passage : 9 mm, 0.4 in

Pump Type		Electric Submersible Pumps
		3-Phase
Motor	Type	Induction Motor
	Insulation	Class F
	Protector	Circle Thermal Protector
	Starter	D.O.L.
Lubricant		Food Grade (ISO VG32)
Impeller Type		Opened
Shaft Seal		Double Mechanical Seal Silicon Carbide VS Ceramic / Carbon
Bearings		C3 Shielded ball bearings
Cable		PVC (CSA Certified) / H07BQ-F 10m (33ft) or longer upon request.
Materials	Pump Casing	Gray Iron
	Impeller	Chromium Iron
	Motor Frame	Stainless Steel
	Motor Shaft	Stainless Steel
	Strainer	Stainless Steel
Max. Liquid Temperature		40°C (104°F)
Max. Submersion Depth		20m (66ft)
pH Range		pH 5 - pH 8

<input checked="" type="checkbox"/>	Simplex
<input type="checkbox"/>	Duplex
<input type="checkbox"/>	Triplex

<input checked="" type="checkbox"/>	OPTIONAL EQUIPMENT
<input type="checkbox"/>	Additional cable 30 □ 40 □ 50 □ 75 □ Ft.
<input type="checkbox"/>	Slide away coupling
<input type="checkbox"/>	Impeller trims
<input type="checkbox"/>	High Temp winding and seal liquids 190°F / 88°C



# SERIES FS Dewatering Pump

SUBMITTAL DATA

50HZ

FS-422

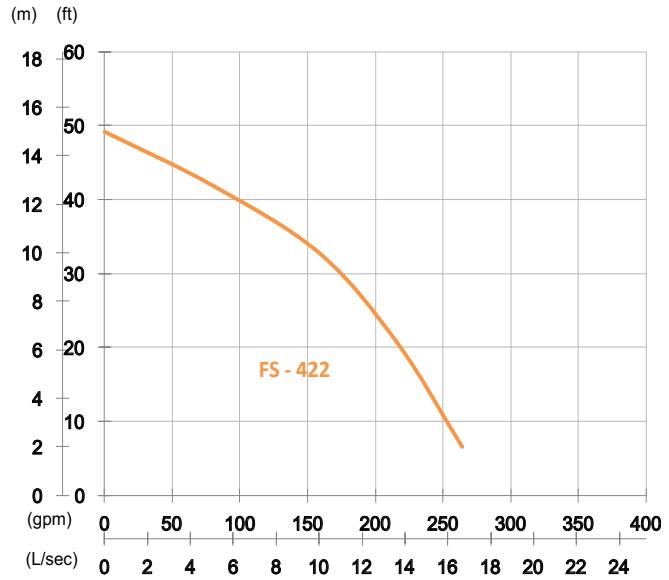

Shaft Speed : 2850 rpm

Outlet : 100mm, 4in

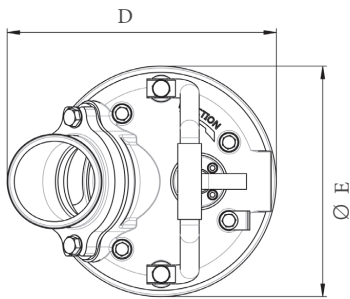

OUTPUT	HEAD	FLOW
2.2 kW	Rated : 10m, 33ft	Rated : 10 L/s, 158 gpm
3 HP	Max : 15m, 49ft	Max : 16.7 L/s, 264 gpm

Solid Passage : 9 mm, 0.4 in

Dimensions	mm	in
A	630	24.8
B		
C	80	3.1
D	284	11.2
E	243	9.6

Pump Type		Electric Submersible Pumps
		3-Phase
Motor	Type	Induction Motor
	Insulation	Class F
	Protector	Circle Thermal Protector
	Starter	D.O.L.
Lubricant		Food Grade (ISO VG32)
Impeller Type		Opened
Shaft Seal		Double Mechanical Seal
		Silicon Carbide VS Ceramic / Carbon
Bearings		C3 Shielded ball bearings
Cable		PVC (CSA Certified) / H07BQ-F
		10m (33ft) or longer upon request.
Materials	Pump Casing	Gray Iron
	Impeller	Chromium Iron
	Motor Frame	Stainless Steel
	Motor Shaft	Stainless Steel
	Strainer	Stainless Steel
Max. Liquid Temperature		40°C (104°F)
Max. Submersion Depth		20m (66ft)
pH Range		pH 5 - pH 8

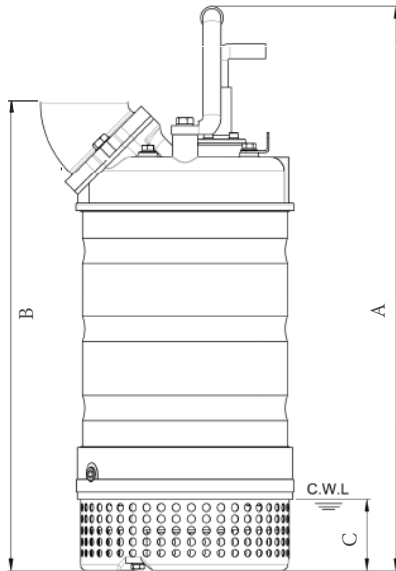

Weight : 43kg / 95 lbs

✓	OPTIONAL EQUIPMENT
Simplex	Additional cable 30 □ 40 □ 50 □ 75 □ Ft.
Duplex	Slide away coupling
Triplex	Impeller trims
	High Temp winding and seal liquids 190°F / 88°C





# SERIES FS Dewatering Pump

SUBMITTAL DATA

50HZ

FS-237

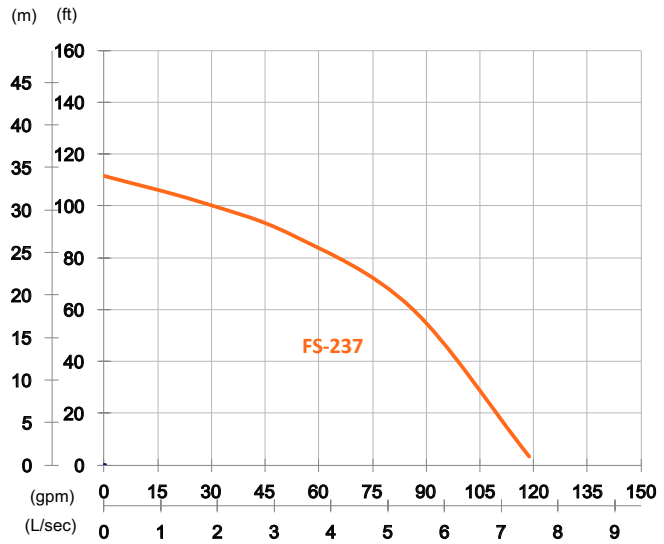

Shaft Speed : 2850 rpm

Outlet : 50mm, 2in

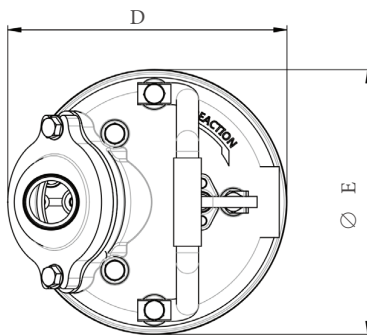

Dimensions	mm	in
A	625	24.6
B		
C	101	4
D	291	11.5
E	283	11.1

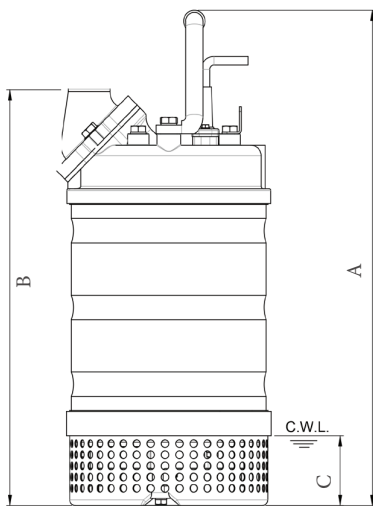

Weight : 61kg / 134 lbs

OUTPUT	HEAD	FLOW
3.7 kW	Rated : 27m, 89ft	Rated : 3.3 L/s, 53 gpm
5 HP	Max : 34m, 112ft	Max : 7.5 L/s, 119 gpm

Solid Passage : 10 mm, 0.4 in

Pump Type		Electric Submersible Pumps
		3-Phase
Motor	Type	Induction Motor
	Insulation	Class F
	Protector	Circle Thermal Protector
	Starter Method	D.O.L.
Lubricant		Food Grade (ISO VG32)
Impeller Type		Opened
Shaft Seal		Double Mechanical Seal Silicon Carbide VS Ceramic / Carbon
Bearings		C3 Shielded ball bearings
Cable		PVC (CSA Certified) / H07BQ-F 10m (33ft) or longer upon request.
Materials	Pump Casing	Gray Iron
	Impeller	Chromium Iron
	Motor Frame	Stainless Steel
	Motor Shaft	Stainless Steel
	Strainer	Stainless Steel
Max. Liquid Temperature		40°C (104°F)
Max. Submersion Depth		20m (66ft)
pH Range		pH 5 - pH 8

<input checked="" type="checkbox"/>	Simplex
<input type="checkbox"/>	Duplex
<input type="checkbox"/>	Triplex

<input checked="" type="checkbox"/>	OPTIONAL EQUIPMENT
<input type="checkbox"/>	Additional cable 30 □ 40 □ 50 □ 75 □ Ft.
<input type="checkbox"/>	Slide away coupling
<input type="checkbox"/>	Impeller trims
<input type="checkbox"/>	High Temp winding and seal liquids 190°F / 88°C

FloFab is certified :



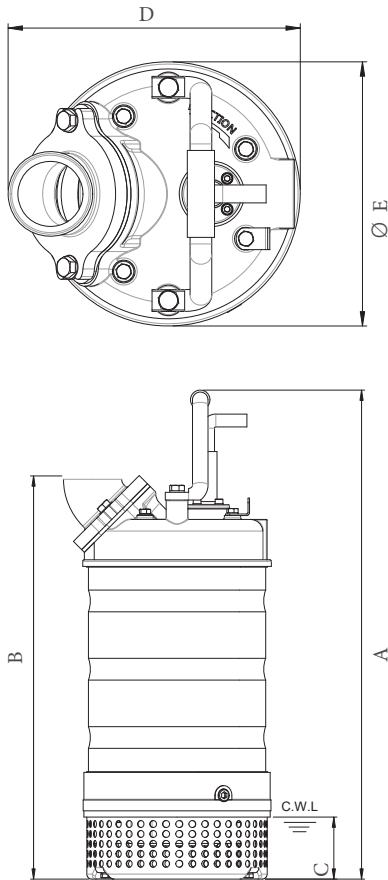

Dimensions	mm	in
A	630	24.8
B		
C	80	3.1
D	269	10.6
E	243	9.6

Weight : 42kg / 93 lbs

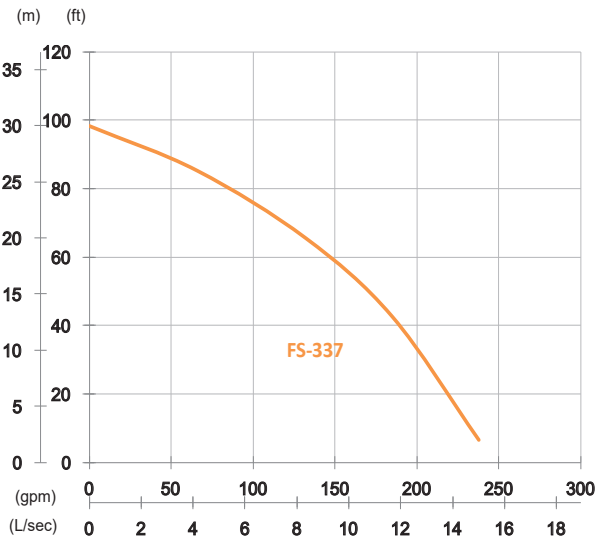

Shaft Speed : 2850 rpm

Outlet : 80mm, 3in

OUTPUT	HEAD	FLOW
3.7 kW	Rated : 20m, 66ft	Rated : 8.3 L/s, 132 gpm
5 HP	Max : 29m, 95ft	Max : 15 L/s, 238 gpm

Solid Passage : 12mm, 0.5in

Pump Type	Electric Submersible Pumps	
	3-Phase	
Motor	Type	Induction Motor
	Insulation	Class F
	Protector	Circle Thermal Protector
	Starter	D.O.L.
Lubricant	Food Grade (ISO VG32)	
Impeller Type	Opened	
Shaft Seal	Double Mechanical Seal	
	Silicon Carbide VS Ceramic / Carbon	
Bearings	C3 Shielded ball bearings	
Cable	PVC (CSA Certified) / H07BQ-F	
	10m (33ft) or longer upon request.	
Materials	Pump Casing	Gray Iron
	Impeller	Chromium Iron
	Motor Frame	Stainless Steel
	Motor Shaft	Stainless Steel
	Strainer	Stainless Steel
Max. Liquid Temperature	40°C (104°F)	
Max. Submersion Depth	20m (66ft)	
pH Range	pH 5 - pH 8	

<input checked="" type="checkbox"/>	
<input type="checkbox"/>	Simplex
<input type="checkbox"/>	Duplex
<input type="checkbox"/>	Triplex

<input checked="" type="checkbox"/>	OPTIONAL EQUIPMENT
<input type="checkbox"/>	Additional cable 30 □ 40 □ 50 □ 75 □ Ft.
<input type="checkbox"/>	Slide away coupling
<input type="checkbox"/>	Impeller trims
<input type="checkbox"/>	High Temp winding and seal liquids 190°F / 88°C





# SERIES FS Dewatering Pump

SUBMITTAL DATA

50HZ

FS-437

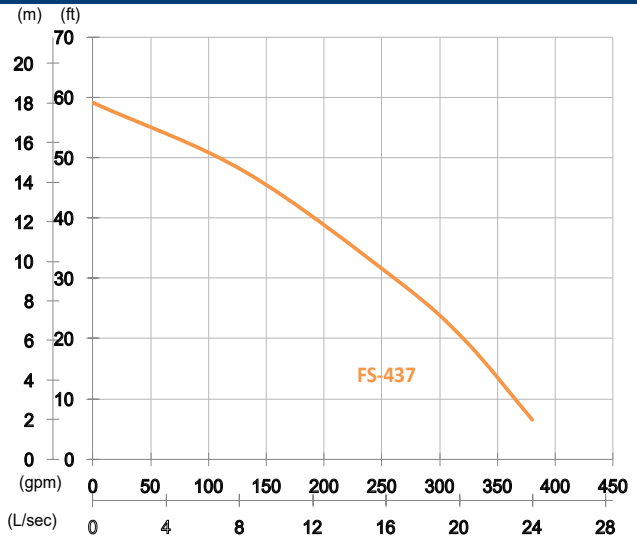

Shaft Speed : 2850 rpm

Outlet : 100mm, 4in

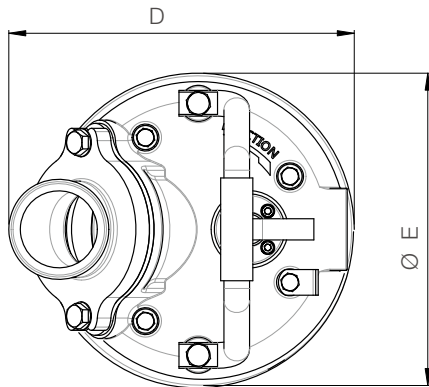

Dimensions	mm	in
A	630	24.8
B		
C	80	3.1
D	284	11.2
E	243	9.6

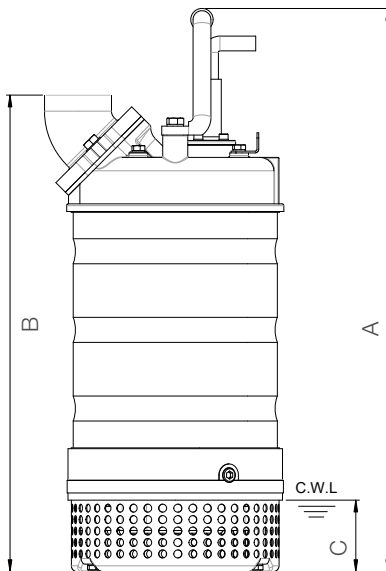

Weight : 42kg / 93 lbs

OUTPUT	HEAD	FLOW
3.7 kW	Rated : 9m, 30ft	Rated : 16.7 L/s, 264 gpm
5 HP	Max : 18m, 59ft	Max : 24 L/s, 380 gpm

Solid Passage : 9mm, 0.4in

Pump Type		Electric Submersible Pumps
		3-Phase
Motor	Type	Induction Motor
	Insulation	Class F
	Protector	Circle Thermal Protector
	Starter	D.O.L.
Lubricant		Food Grade (ISO VG32)
Impeller Type		Opened
Shaft Seal		Double Mechanical Seal
		Silicon Carbide VS Ceramic / Carbon
Bearings		C3 Shielded ball bearings
Cable		PVC (CSA Certified) / H07BQ-F
		10m (33ft) or longer upon request.
Materials	Pump Casing	Gray Iron
	Impeller	Chromium Iron
	Motor Frame	Stainless Steel
	Motor Shaft	Stainless Steel
	Strainer	Stainless Steel
Max. Liquid Temperature		40°C (104°F)
Max. Submersion Depth		20m (66ft)
pH Range		pH 5 - pH 8

✓	OPTIONAL EQUIPMENT
Simplex	Additional cable 30 □ 40 □ 50 □ 75 □ Ft.
Duplex	Slide away coupling
Triplex	Impeller trims
	High Temp winding and seal liquids 190°F / 88°C





# SERIES FS Dewatering Pump

SUBMITTAL DATA

50HZ

FS-355

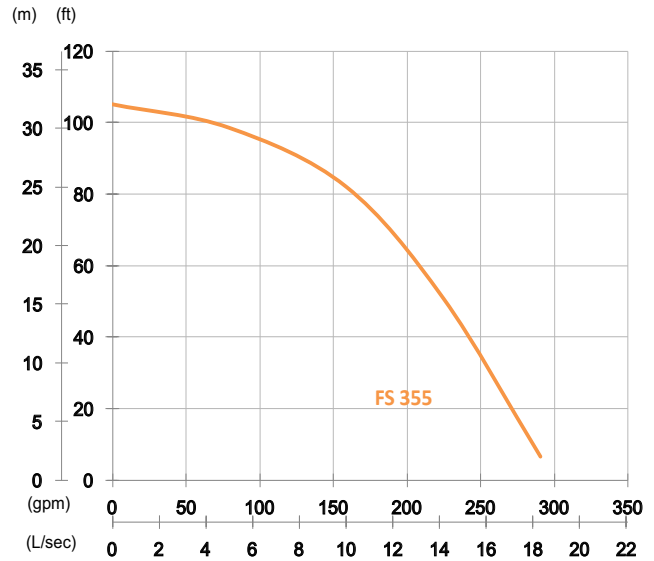

Shaft Speed : 2850 rpm

Outlet : 80mm, 3in

OUTPUT	HEAD	FLOW
5.5 kW	Rated : 25m, 82ft	Rated : 10 L/s, 158 gpm
7.5 HP	Max : 32m, 105ft	Max : 18.3 L/s, 290 gpm

Solid Passage : 10 mm, 0.4 in

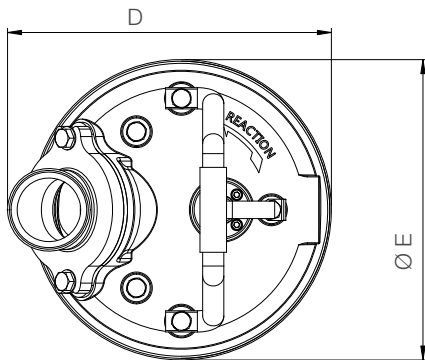

Dimensions	mm	in
A	656	25.8
B		
C	101	4
D	306	12
E	283	11.1

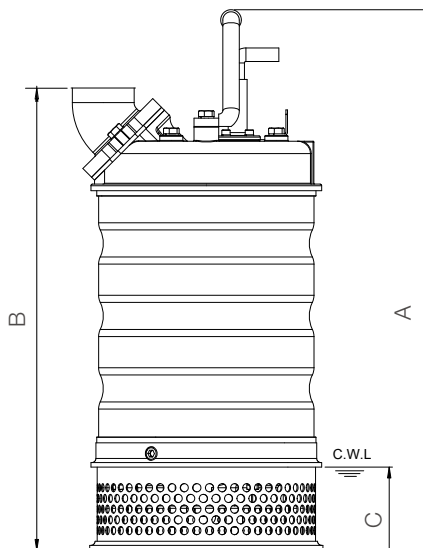

Weight : 60kg / 132 lbs

Pump Type		Electric Submersible Pumps	
		3-Phase	
Motor	Type	Induction Motor	
	Insulation	Class F	
	Protector	Circle Thermal Protector	
	Starter	D.O.L.	
Lubricant		Food Grade (ISO VG32)	
Impeller Type		Opened	
Shaft Seal		Double Mechanical Seal Silicon Carbide VS Ceramic / Carbon	
Bearings		C3 Shielded ball bearings	
Cable		PVC (CSA Certified) / H07BQ-F 10m (33ft) or longer upon request.	
Materials	Pump Casing	Gray Iron	
	Impeller	Chromium Iron	
	Motor Frame	Stainless Steel	
	Motor Shaft	Stainless Steel	
		Strainer	Stainless Steel
Max. Liquid Temperature		40°C (104°F)	
Max. Submersion Depth		20m (66ft)	

✓	OPTIONAL EQUIPMENT
Simplex	Additional cable 30 □ 40 □ 50 □ 75 □ Ft.
Duplex	Slide away coupling
Triplex	Impeller trims
	High Temp winding and seal liquids 190°F / 88°C

FloFab is certified :   

FS-455

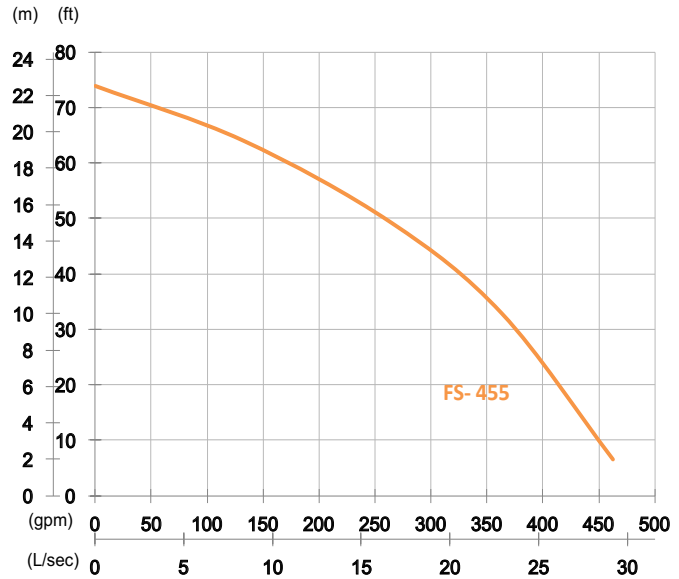

Shaft Speed : 2850 rpm

Outlet : 100mm, 4in

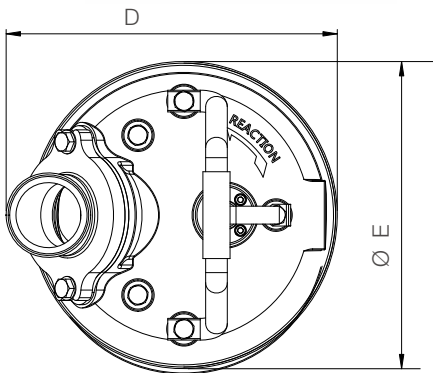

Dimensions	mm	in
A	656	25.8
B		
C	101	4
D	320	12.6
E	283	11.1

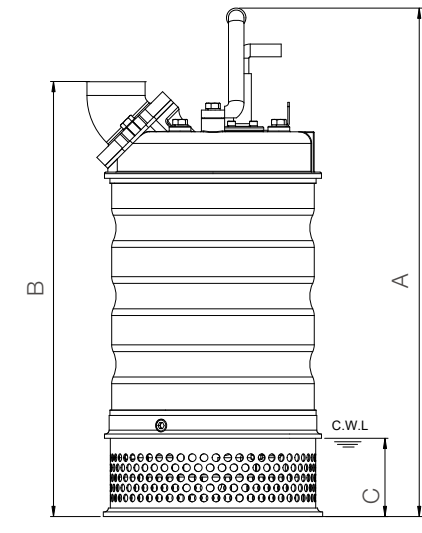

Weight : 60kg / 132 lbs

OUTPUT	HEAD	FLOW
5.5 kW	Rated : 15m, 49ft	Rated: 16.7 L/s, 264 gpm
7.5 HP	Max : 22.5m, 74ft	Max : 29.1 L/s, 462 gpm

Solid Passage : 10 mm, 0.4 in

Pump Type		Electric Submersible Pumps
		3-Phase
Motor	Type	Induction Motor
	Insulation	Class F
	Protector	Circle Thermal Protector
	Starter	D.O.L.
Lubricant		Food Grade (ISO VG32)
Impeller Type		Opened
Shaft Seal		Double Mechanical Seal
		Silicon Carbide VS Ceramic / Carbon
Bearings		C3 Shielded ball bearings
Cable		PVC (CSA Certified) / H07BQ-F
		10m (33ft) or longer upon request.
Materials	Pump Casing	Gray Iron
	Impeller	Chromium Iron
	Motor Frame	Stainless Steel
	Motor Shaft	Stainless Steel
		Stainless Steel
Max. Liquid Temperature		40°C (104°F)
Max. Submersion Depth		20m (66ft)
pH Range		pH 5 - pH 8

✓	OPTIONAL EQUIPMENT
Simplex	Additional cable 30 □ 40 □ 50 □ 75 □ Ft.
Duplex	Slide away coupling
Triplex	Impeller trims
	High Temp winding and seal liquids 190°F / 88°C

FS-475N

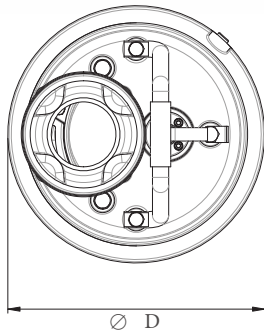

Dimensions	mm	in
A	801	31.5
B	629	24.8
C	135	5.3
D	317	12.5

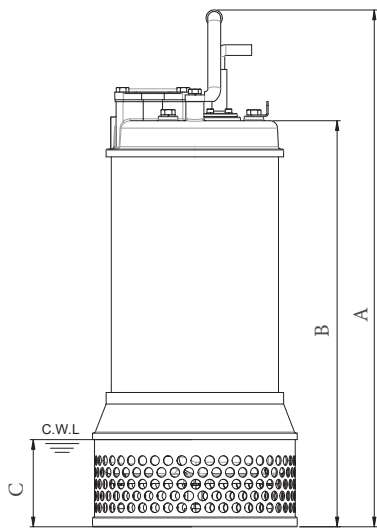

Weight : 93kg / 205 lbs

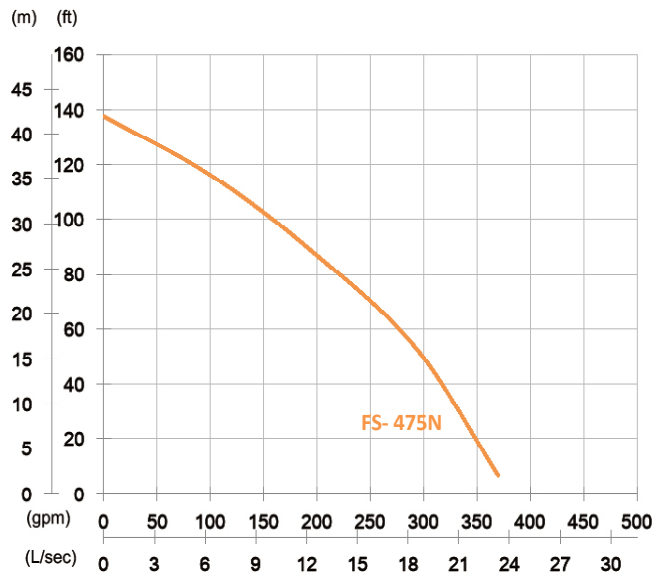

Shaft Speed : 2850 rpm

Outlet : 100mm, 4in

OUTPUT	HEAD	FLOW
7.5 kW	Rated : 28m, 92ft	Rated : 11.7 L/s, 185 gpm
10 HP	Max : 42m, 138ft	Max : 23.3 L/s, 370 gpm

Solid Passage : 15 mm, 0.6 in

Pump Type		Electric Submersible Pumps
		3-Phase
Motor	Type	Induction Motor
	Insulation	Class F
	Protector	Circle Thermal Protector
	Starter	D.O.L.
Lubricant		Food Grade (ISO VG32)
Impeller Type		Opened
Shaft Seal		Double Mechanical Seal Silicon Carbide VS Ceramic / Carbon
Bearings		C3 Shielded ball bearings
Cable		PVC (CSA Certified) / H07BQ-F 10m (33ft) or longer upon request.
Materials	Pump Casing	Gray Iron
	Impeller	Chromium Iron
	Motor Frame	Stainless Steel
	Motor Shaft	Stainless Steel
Strainer		Stainless Steel
Max. Liquid Temperature		40°C (104°F)
Max. Submersion Depth		20m (66ft)
pH Range		pH 5 - pH 8

<input checked="" type="checkbox"/>	
<input type="checkbox"/>	Simplex
<input type="checkbox"/>	Duplex
<input type="checkbox"/>	Triplex

<input checked="" type="checkbox"/>	OPTIONAL EQUIPMENT
<input type="checkbox"/>	Additional cable 30 □ 40 □ 50 □ 75 □ Ft.
<input type="checkbox"/>	Slide away coupling
<input type="checkbox"/>	Impeller trims
<input type="checkbox"/>	High Temp winding and seal liquids 190°F / 88°C

FS-675N

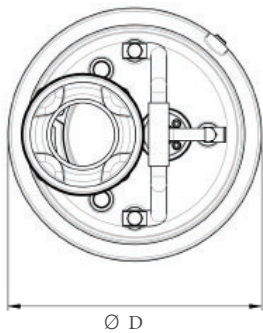

Dimensions	mm	in
A	---	---
B	629	24.8
C	135	5.3
D	317	12.5

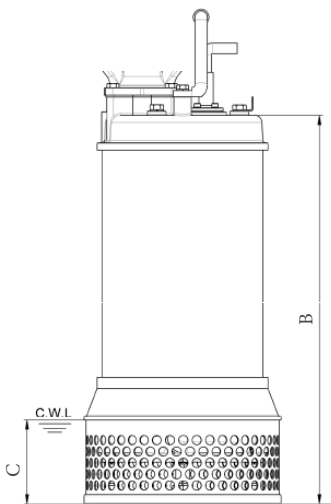

Weight : 97kg / 214 lbs

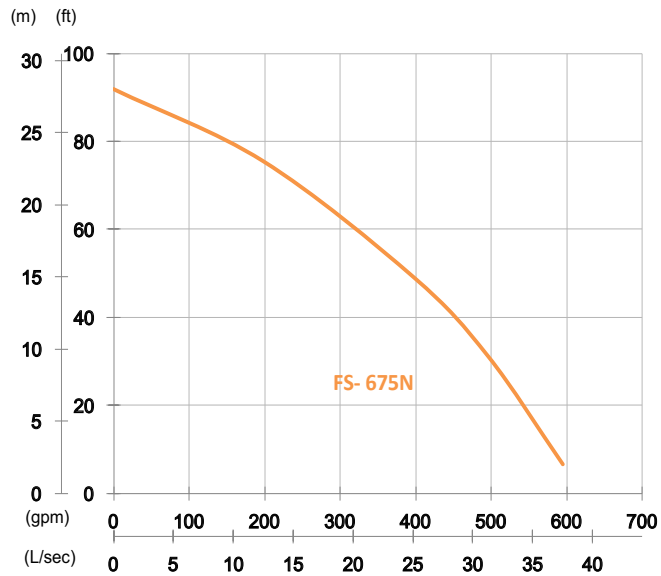

Shaft Speed : 2850 rpm

Outlet : 150mm, 6in

OUTPUT	HEAD	FLOW
7.5 kW	Rated : 15m, 49ft	Rated : 25 L/s, 396 gpm
10 HP	Max : 28m, 92ft	Max : 37.5 L/s, 594 gpm

Solid Passage : 15 mm, 0.6 in

Pump Type		Electric Submersible Pumps
		3-Phase
Motor	Type	Induction Motor
	Insulation	Class F
	Protector	Circle Thermal Protector
	Starter	D.O.L.
Lubricant		Food Grade (ISO VG32)
Impeller Type		Opened
Shaft Seal		Double Mechanical Seal Silicon Carbide VS Ceramic / Carbon
Bearings		C3 Shielded ball bearings
Cable		PVC (CSA Certified) / H07BQ-F 10m (33ft) or longer upon request.
Materials	Pump Casing	Gray Iron
	Impeller	Chromium Iron
	Motor Frame	Stainless Steel
	Motor Shaft	Stainless Steel
Strainer		Stainless Steel
Max. Liquid Temperature		40°C (104°F)
Max. Submersion Depth		20m (66ft)
pH Range		pH 5 - pH 8

<input checked="" type="checkbox"/>	
<input type="checkbox"/>	Simplex
<input type="checkbox"/>	Duplex
<input type="checkbox"/>	Triplex

<input checked="" type="checkbox"/>	OPTIONAL EQUIPMENT
<input type="checkbox"/>	Additional cable 30 □ 40 □ 50 □ 75 □ Ft.
<input type="checkbox"/>	Slide away coupling
<input type="checkbox"/>	Impeller trims
<input type="checkbox"/>	High Temp winding and seal liquids 190°F / 88°C

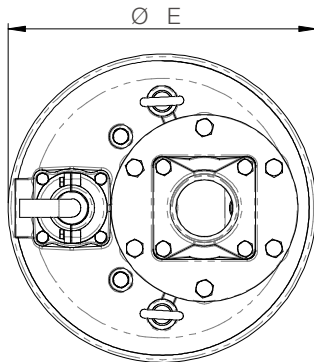

Dimensions	mm	in
A		
B	697	27.4
C	145	5.7
D	758	29.8
E	354	14

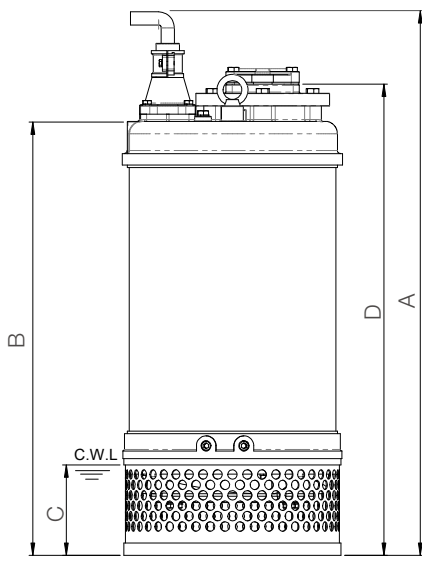

Weight : 135kg / 298 lbs

✓	OPTIONAL EQUIPMENT
Simplex	Additional cable 30 □ 40 □ 50 □ 75 □ Ft.
Duplex	Slide away coupling
Triplex	Impeller trims
	High Temp winding and seal liquids 190°F / 88°C

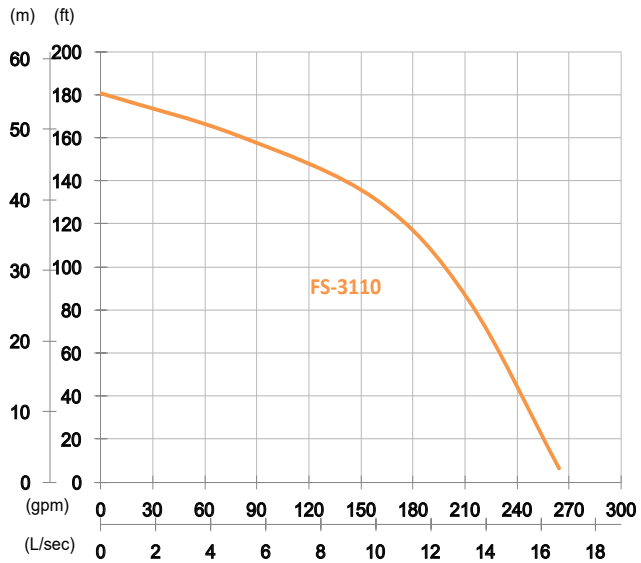

Shaft Speed : 2850 rpm

Outlet : 80mm, 3in

OUTPUT	HEAD	FLOW
11 kW	Rated : 40m, 131ft	Rated : 10 L/s, 158 gpm
15 HP	Max : 55m, 180ft	Max : 16.7 L/s, 264 gpm

Solid Passage : 10mm, 0.4in

Pump Type		Electric Submersible Pumps
		3-Phase
Motor	Type	Induction Motor
	Insulation	Class F
	Protector	Circle Thermal Protector
	Starter	D.O.L.
Lubricant		Food Grade (ISO VG32)
Impeller Type		Opened
Shaft Seal		Double Mechanical Seal
		Silicon Carbide VS Ceramic / Carbon
Bearings		C3 Shielded ball bearings
Cable		PVC (CSA Certified) / H07BQ-F
		10m (33ft) or longer upon request.
Materials	Pump Casing	Gray Iron
	Impeller	Chromium Iron
	Motor Frame	Gray Iron
	Motor Shaft	Stainless Steel
		Stainless Steel
Max. Liquid Temperature		40°C (104°F)
Max. Submersion Depth		20m (66ft)
pH Range		pH 5 - pH 8

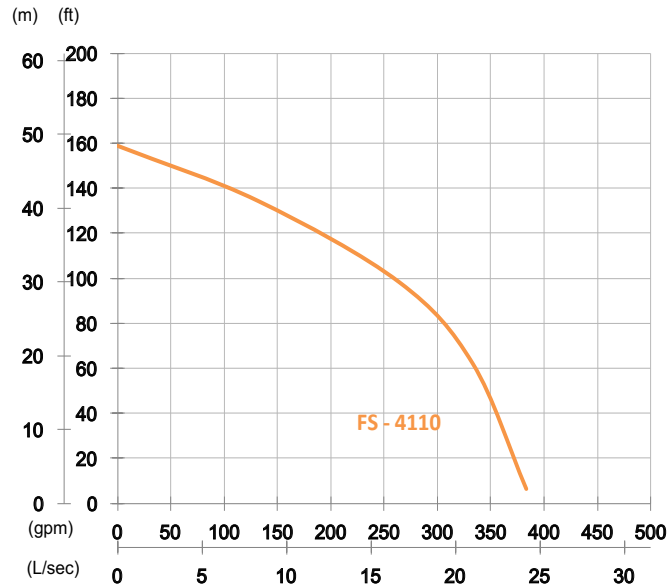

Shaft Speed : 2850 rpm

Outlet : 100mm, 4in

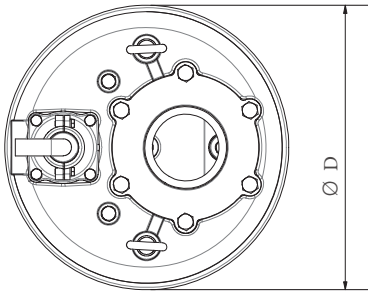

Dimensions	mm	in
A	----	----
B	697	27.4
C	145	5.7
D	354	13.9

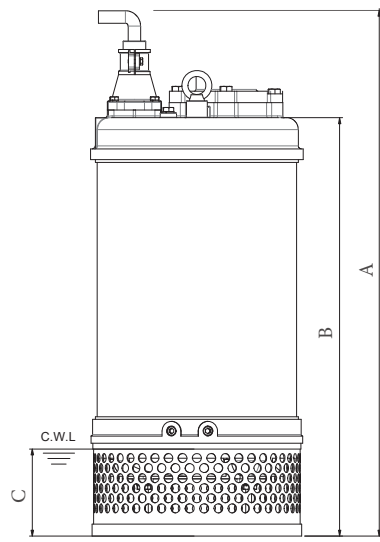

Weight : 135kg / 298 lbs

OUTPUT	HEAD	FLOW
11 kW	Rated : 30m, 98ft	Rated : 16.7 L/s, 264 gpm
15 HP	Max : 48.5m, 159ft	Max : 24.2 L/s, 383 gpm

Solid Passage : 10 mm, 0.4 in

Pump Type		Electric Submersible Pumps
		3-Phase
Motor	Type	Induction Motor
	Insulation	Class F
	Protector	Circle Thermal Protector
	Starter	D.O.L.
Lubricant		Food Grade (ISO VG32)
Impeller Type		Opened
Shaft Seal		Double Mechanical Seal Silicon Carbide VS Ceramic / Carbon
Bearings		C3 Shielded ball bearings
Cable		PVC (CSA Certified) / H07BQ-F 10m (33ft) or longer upon request.
Materials	Pump Casing	Gray Iron
	Impeller	Chromium Iron
	Motor Frame	Gray Iron
	Motor Shaft	Stainless Steel
	Strainer	Stainless Steel
Max. Liquid Temperature		40°C (104°F)
Max. Submersion Depth		20m (66ft)
pH Range		pH 5 - pH 8

<input checked="" type="checkbox"/>	Simplex
<input type="checkbox"/>	Duplex
<input type="checkbox"/>	Triplex

<input checked="" type="checkbox"/>	OPTIONAL EQUIPMENT
<input type="checkbox"/>	Additional cable 30 □ 40 □ 50 □ 75 □ Ft.
<input type="checkbox"/>	Slide away coupling
<input type="checkbox"/>	Impeller trims
<input type="checkbox"/>	High Temp winding and seal liquids 190°F / 88°C



# SERIES FS Dewatering Pump

SUBMITTAL DATA

50HZ

FS-6110

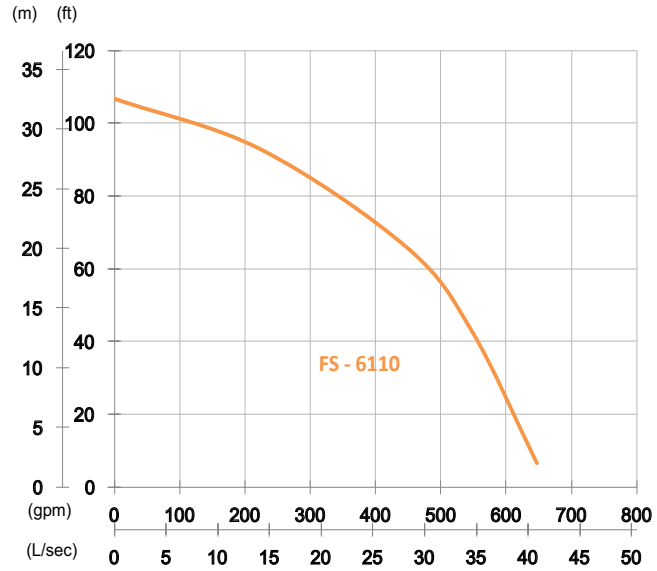

Shaft Speed : 2850 rpm

Outlet : 150mm, 6in

OUTPUT	HEAD	FLOW
11 kW	Rated : 20m, 66ft	Rated : 28.3 L/s, 449 gpm
15 HP	Max : 32.5m, 107ft	Max : 40.8 L/s, 647 gpm

Solid Passage : 15 mm, 0.6 in

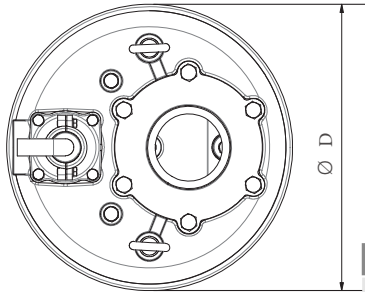

Dimensions	mm	in
A	---	---
B	697	27.4
C	145	5.7
D	354	13.9

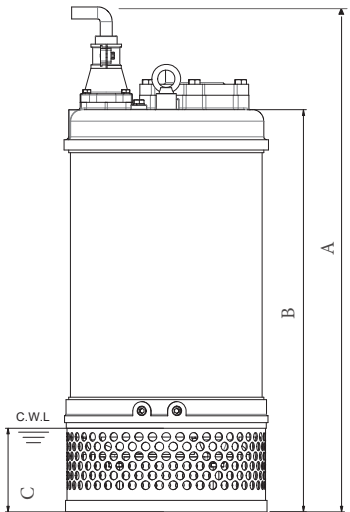

Weight : 137kg / 302 lbs

Pump Type		Electric Submersible Pumps
		3-Phase
Motor	Type	Induction Motor
	Insulation	Class F
	Protector	Circle Thermal Protector
	Starter	D.O.L.
Lubricant		Food Grade (ISO VG32)
Impeller Type		Opened
Shaft Seal		Double Mechanical Seal Silicon Carbide VS Ceramic / Carbon
Bearings		C3 Shielded ball bearings
Cable		PVC (CSA Certified) / H07BQ-F 10m (33ft) or longer upon request.
Materials	Pump Casing	Gray Iron
	Impeller	Chromium Iron
	Motor Frame	Gray Iron
	Motor Shaft	Stainless Steel
	Strainer	Stainless Steel
Max. Liquid Temperature		40°C (104°F)
Max. Submersion Depth		20m (66ft)
pH Range		pH 5 - pH 8

<input checked="" type="checkbox"/>	Simplex
<input type="checkbox"/>	Duplex
<input type="checkbox"/>	Triplex

<input checked="" type="checkbox"/>	OPTIONAL EQUIPMENT
<input type="checkbox"/>	Additional cable 30 □ 40 □ 50 □ 75 □ Ft.
<input type="checkbox"/>	Slide away coupling
<input type="checkbox"/>	Impeller trims
<input type="checkbox"/>	High Temp winding and seal liquids 190°F / 88°C

FloFab is certified :



FS-4150

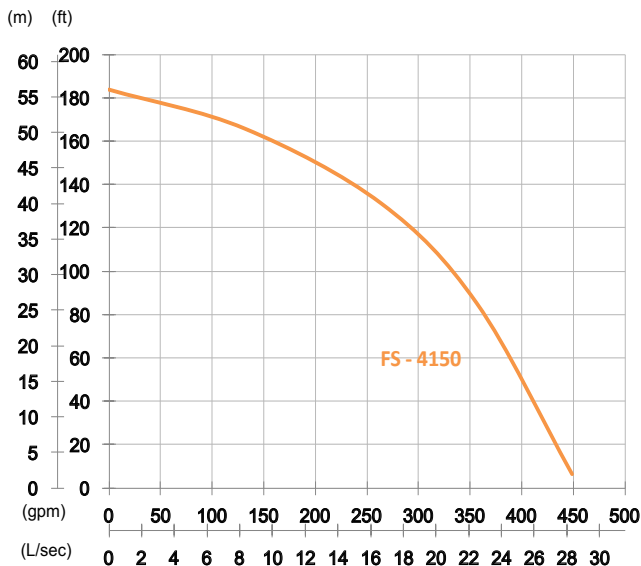

Shaft Speed : 2850 rpm

Outlet : 100mm, 4in

OUTPUT	HEAD	FLOW
15 kW	Rated : 40m, 131ft	Rated : 16.7 L/s, 264 gpm
20 HP	Max : 56m, 184ft	Max : 28.3 L/s, 449 gpm

Solid Passage : 15 mm, 0.6 in

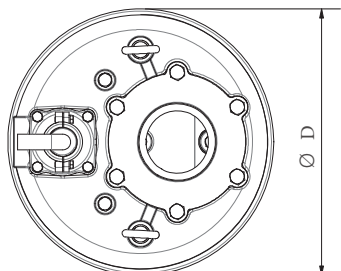

Dimensions	mm	in
A	----	----
B	726	28.6
C	145	5.7
D	354	13.9

Pump Type		Electric Submersible Pumps	
		3-Phase	
Motor	Type	Induction Motor	
	Insulation	Class F	
	Protector	Circle Thermal Protector	
	Starter	D.O.L.	
Lubricant		Food Grade (ISO VG32)	
Impeller Type		Opened	
Shaft Seal		Double Mechanical Seal Silicon Carbide VS Ceramic / Carbon	
Bearings		C3 Shielded ball bearings	
Cable		PVC (CSA Certified) / H07BQ-F 10m (33ft) or longer upon request.	
Materials	Pump Casing	Gray Iron	
	Impeller	Chromium Iron	
	Motor Frame	Gray Iron	
	Motor Shaft	Stainless Steel	
		Strainer	Stainless Steel
Max. Liquid Temperature		40°C (104°F)	
Max. Submersion Depth		20m (66ft)	
pH Range		pH 5 - pH 8	

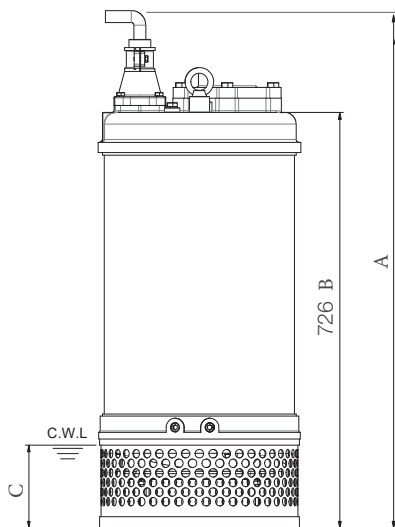

Weight : 141kg / 311 lbs

✓	
	Simplex
	Duplex
	Triplex

✓	OPTIONAL EQUIPMENT
	Additional cable 30 □ 40 □ 50 □ 75 □ Ft.
	Slide away coupling
	Impeller trims
	High Temp winding and seal liquids 190°F / 88°C



# SERIES FS Dewatering Pump

SUBMITTAL DATA

50HZ

FS-6150

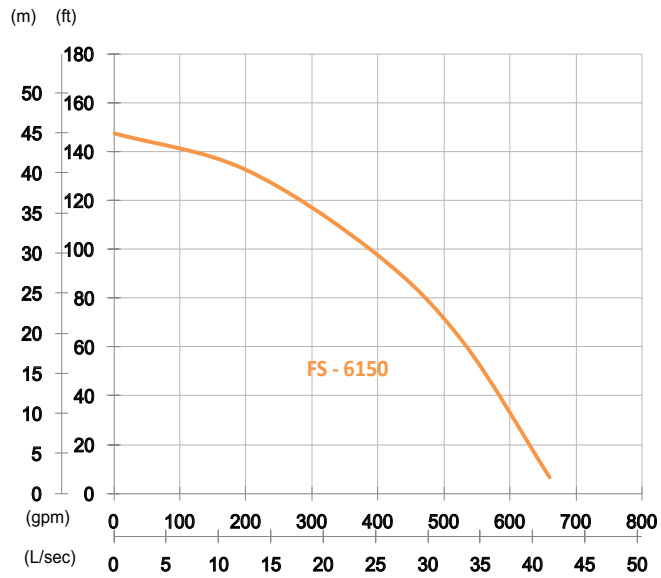

Shaft Speed : 2850 rpm

Outlet : 150mm, 6in

OUTPUT	HEAD	FLOW
15 kW	Rated : 30m, 98ft	Rated : 25 L/s, 396 gpm
20 HP	Max : 45m, 148ft	Max : 41.6 L/s, 660 gpm

Solid Passage : 15 mm, 0.6 in

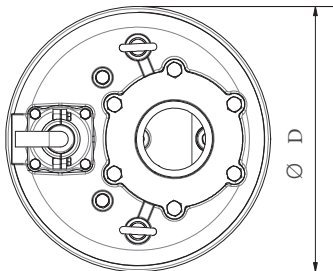

Dimensions	mm	in
A	---	---
B	726	28.6
C	145	5.7
D	354	13.9

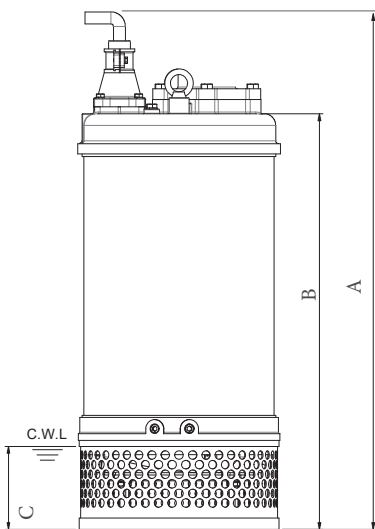

Weight : 142kg / 313 lbs

Pump Type		Electric Submersible Pumps
		3-Phase
Motor	Type	Induction Motor
	Insulation	Class F
	Protector	Circle Thermal Protector
	Starter	D.O.L.
Lubricant		Food Grade (ISO VG32)
Impeller Type		Opened
Shaft Seal		Double Mechanical Seal Silicon Carbide VS Ceramic / Carbon
Bearings		C3 Shielded ball bearings
Cable		PVC (OSA Certified) / H07BQ-F 10m (33ft) or longer upon request.
Materials	Pump Casing	Gray Iron
	Impeller	Chromium Iron
	Motor Frame	Gray Iron
	Motor Shaft	Stainless Steel
	Strainer	Stainless Steel
Max. Liquid Temperature		40°C (104°F)
Max. Submersion Depth		20m (66ft)
pH Range		pH 5 - pH 8

✓	OPTIONAL EQUIPMENT
Simplex	Additional cable 30 □ 40 □ 50 □ 75 □ Ft.
Duplex	Slide away coupling
Triplex	Impeller trims
	High Temp winding and seal liquids 190°F / 88°C

FloFab is certified :

#### FS-4220

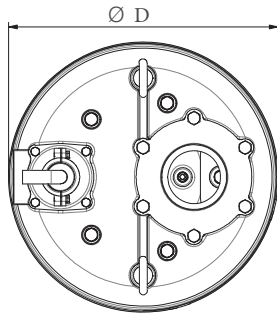
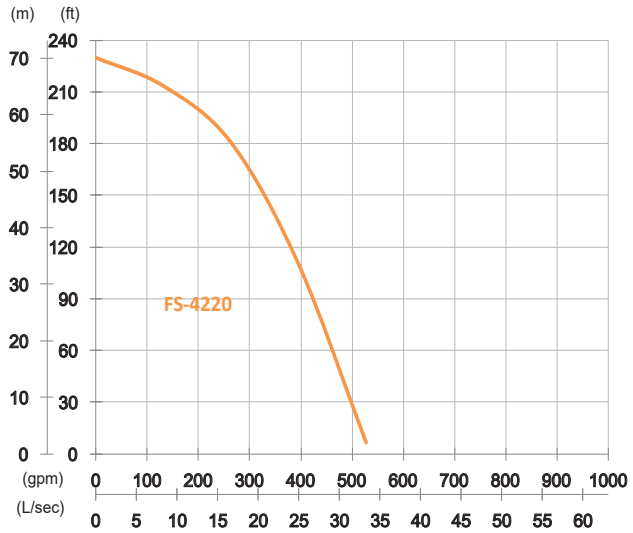

Dimensions	mm	in
A	---	---
B	920	36.2
C	227	8.9
D	424	16.7

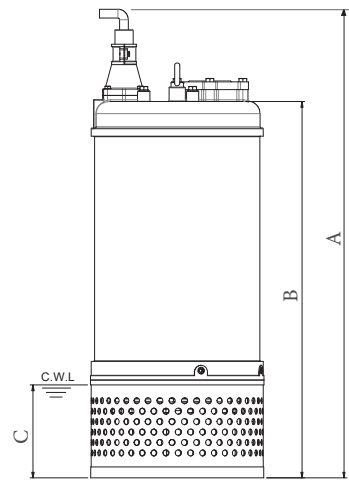

Weight : 256kg / 564 lbs

Shaft Speed : 2850 rpm

Outlet : 100mm, 4in

OUTPUT	HEAD	FLOW
22 kW	Rated : 55m, 180ft	Rated : 16.7 L/s, 264 gpm
30 HP	Max : 70m, 230ft	Max : 33.3 L/s, 528 gpm
Solid Passage : 15mm, 0.6in		

Pump Type		Electric Submersible Pumps	
		3-Phase	
Motor	Type	Induction Motor	
	Insulation	Class F	
	Protector	Circle Thermal Protector	
	Starter	D.O.L.	
Lubricant		Food Grade (ISO VG32)	
Impeller Type		Opened	
Shaft Seal		Double Mechanical Seal Silicon Carbide VS Ceramic / Carbon	
Bearings		C3 Shielded ball bearings	
Cable		PVC (CSA Certified) / H07BQ-F 10m (33ft) or longer upon request.	
Materials	Pump Casing	Gray Iron	
	Impeller	Chromium Iron	
	Motor Frame	Gray Iron	
	Motor Shaft	Stainless Steel	
		Strainer	Stainless Steel
Max. Liquid Temperature		40°C (104°F)	
Max. Submersion Depth		20m (66ft)	
pH Range		pH 5 - pH 8	

<input checked="" type="checkbox"/>	Simplex
<input type="checkbox"/>	Duplex
<input type="checkbox"/>	Triplex

<input checked="" type="checkbox"/>	OPTIONAL EQUIPMENT
<input type="checkbox"/>	Additional cable 30 □ 40 □ 50 □ 75 □ Ft.
<input type="checkbox"/>	Slide away coupling
<input type="checkbox"/>	Impeller trims
<input type="checkbox"/>	High Temp winding and seal liquids 190°F / 88°C



# SERIES FS Dewatering Pump

FS-6220

SUBMITTAL DATA

50HZ

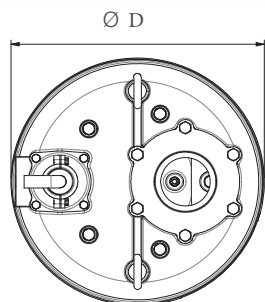

Dimensions	mm	in
A	---	---
B	922	36.3
C	227	8.9
D	424	16.7

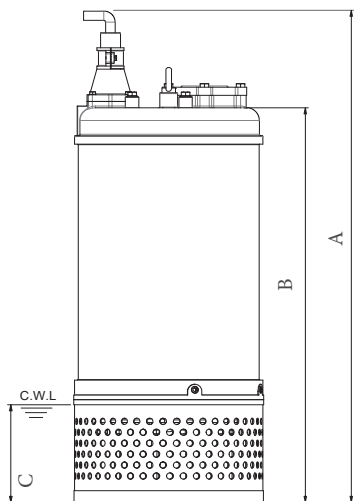

Weight : 259kg / 571 lbs

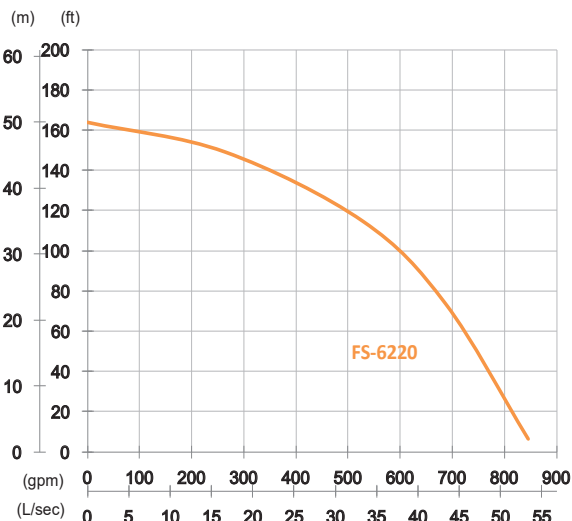

Shaft Speed : 2850 rpm

Outlet : 150mm, 6in

OUTPUT	HEAD	FLOW
22 kW	Rated : 35m, 115ft	Rated : 33.3 L/s, 528 gpm
30 HP	Max : 50m, 164ft	Max : 53.3 L/s, 845 gpm

Solid Passage : 20mm, 0.8in

Pump Type		Electric Submersible Pumps
		3-Phase
Motor	Type	Induction Motor
	Insulation	Class F
	Protector	Circle Thermal Protector
	Starter	D.O.L.
Lubricant		Food Grade (ISO VG32)
Impeller Type		Opened
Shaft Seal		Double Mechanical Seal
		Silicon Carbide VS Ceramic / Carbon
Bearings		C3 Shielded ball bearings
Cable		PVC (CSA Certified) / H07BQ-F
		10m (33ft) or longer upon request.
Materials	Pump Casing	Gray Iron
	Impeller	Chromium Iron
	Motor Frame	Gray Iron
	Motor Shaft	Stainless Steel
	Strainer	Stainless Steel
Max. Liquid Temperature		40°C (104°F)
Max. Submersion Depth		20m (66ft)
pH Range		pH 5 - pH 8

<input checked="" type="checkbox"/>	
<input type="checkbox"/>	Simplex
<input type="checkbox"/>	Duplex
<input type="checkbox"/>	Triplex

<input checked="" type="checkbox"/>	OPTIONAL EQUIPMENT
<input type="checkbox"/>	Additional cable 30 □ 40 □ 50 □ 75 □ Ft.
<input type="checkbox"/>	Slide away coupling
<input type="checkbox"/>	Impeller trims
<input type="checkbox"/>	High Temp winding and seal liquids 190°F / 88°C

FloFab is certified :   



# SERIES FS Dewatering Pump

SUBMITTAL DATA

50HZ

FS-8220

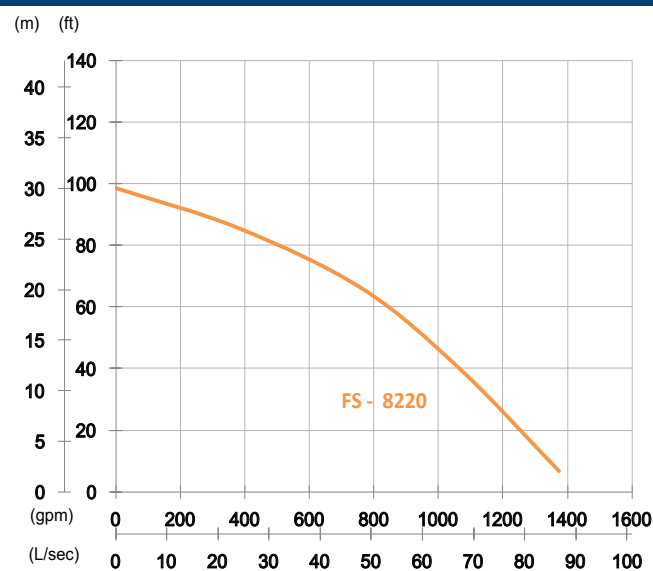

Shaft Speed : 2850 rpm Outlet : 200mm, 8in

OUTPUT	HEAD	FLOW
22 kW	Rated : 20m, 66ft	Rated : 48.3 L/s, 766 gpm
30 HP	Max : 30m, 98ft	Max : 86.6 L/s, 1373 gpm

Solid Passage : 20 mm, 0.8 in

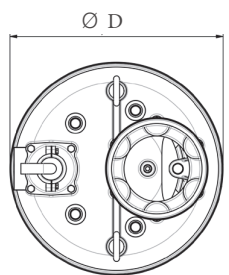

Dimensions	mm	in
A	1154	45.4
B	922	36.3
C	227	8.9
D	424	16.7

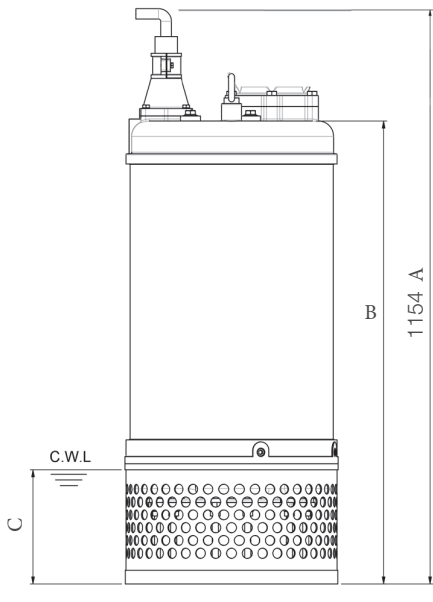

Weight : 264kg / 582 lbs

Pump Type		Electric Submersible Pumps	
		3-Phase	
Motor	Type	Induction Motor	
	Insulation	Class F	
	Protector	Circle Thermal Protector	
	Starter	D.O.L.	
Lubricant		Food Grade (ISO VG32)	
Impeller Type		Opened	
Shaft Seal		Double Mechanical Seal	
		Silicon Carbide VS Ceramic / Carbon	
Bearings		C3 Shielded ball bearings	
Cable		PVC (CSA Certified) / H07BQ-F	
		10m (33ft) or longer upon request.	
Materials	Pump Casing	Gray Iron	
	Impeller	Chromium Iron	
	Motor Frame	Gray Iron	
	Motor Shaft	Stainless Steel	
		Strainer	Stainless Steel
Max. Liquid Temperature		40°C (104°F)	
Max. Submersion Depth		20m (66ft)	
pH Range		pH 5 - pH 8	

<input checked="" type="checkbox"/>	Simplex
<input type="checkbox"/>	Duplex
<input type="checkbox"/>	Triplex

<input checked="" type="checkbox"/>	OPTIONAL EQUIPMENT
<input type="checkbox"/>	Additional cable 30 □ 40 □ 50 □ 75 □ Ft.
<input type="checkbox"/>	Slide away coupling
<input type="checkbox"/>	Impeller trims
<input type="checkbox"/>	High Temp winding and seal liquids 190°F / 88°C

FloFab is certified :

#### FSS-400

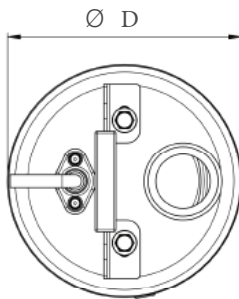

Dimensions	mm	in
A	333	13.1
B	247	9.7
C	52	2
D	180	7.1

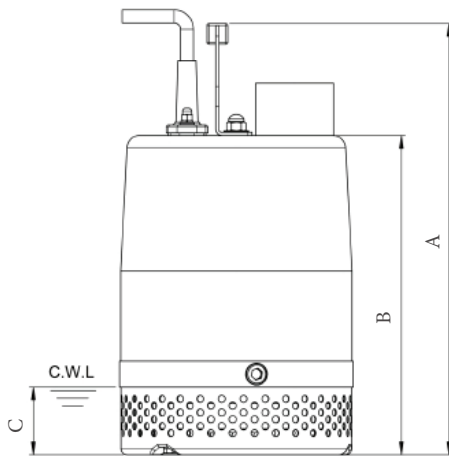

Weight : 13kg / 29 lbs

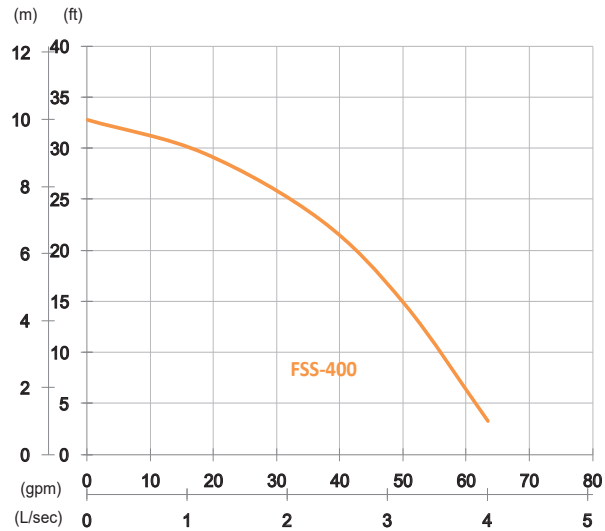

Shaft Speed : 2850 rpm

Outlet : 50mm, 2in

OUTPUT	HEAD	FLOW
0.4 kW	Rated : 7m, 23ft	Rated : 2.3 L/s, 37 gpm
0.5 HP	Max : 10m, 33ft	Max : 4 L/s, 63 gpm

Solid Passage : 5.5mm, 0.2in

Pump Type		Electric Submersible Pumps
		1-Phase, 3-Phase
Motor	Type	Induction Motor
	Insulation	Class F
	Protector	Circle Thermal Protector
	Starter	1-Phase · Capacitor-Run, 3-Phase · D.O.L.
Lubricant		Food Grade (ISO VG32)
Impeller Type		Opened
Shaft Seal		Double Mechanical Seal Silicon Carbide VS Ceramic / Carbon
Bearings		C3 Shielded ball bearings
Cable		PVC (CSA Certified) / H07RN-F 6m (20ft) or longer upon request.
Materials	Pump Casing	Stainless Steel
	Impeller	Stainless Steel
	Motor Frame	Stainless Steel
	Motor Shaft	Stainless Steel
	Strainer	Stainless Steel
Max. Liquid Temperature		40°C (104°F)
Max. Submersion Depth		20m (66ft)
pH Range		pH 5 - pH 8

✓	
	Simplex
	Duplex
	Triplex

✓	OPTIONAL EQUIPMENT
	Additional cable 30 □ 40 □ 50 □ 75 □ Ft.
	Slide away coupling
	Impeller trims
	High Temp winding and seal liquids 190°F / 88°C



# SERIES FSS Dewatering Pump

SUBMITTAL DATA

50HZ

FSS-750

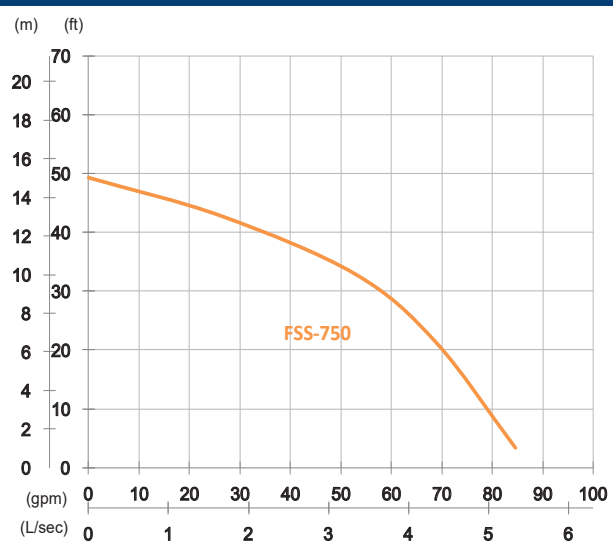

Shaft Speed : 2850 rpm

Outlet : 50mm, 2in

OUTPUT	HEAD	FLOW
0.75 kW	Rated : 10m, 33ft	Rated : 3.3 L/s, 53 gpm
1 HP	Max : 15m, 49ft	Max : 5.3 L/s, 84 gpm

Solid Passage : 7mm, 0.3in

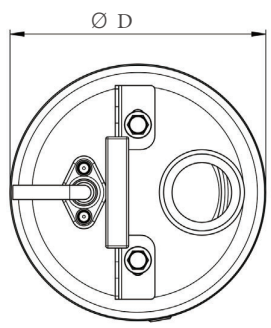

Dimensions	mm	in
A	361	14.2
B	274	10.8
C	52	2
D	180	7.1

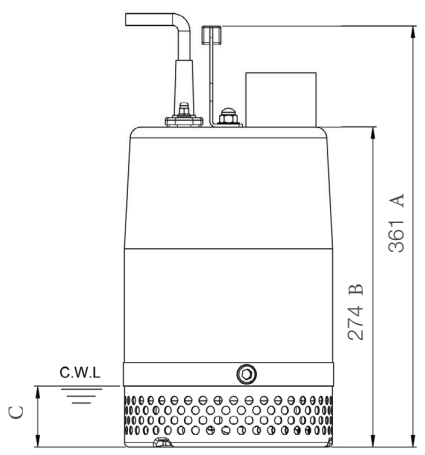

Weight : 14kg / 31 lbs

Pump Type		Electric Submersible Pumps
		1-Phase, 3-Phase
Motor	Type	Induction Motor
	Insulation	Class F
	Protector	Circle Thermal Protector
	Starter	1-Phase · Capacitor-Run, 3-Phase · D.O.L.
Lubricant		Food Grade (ISO VG32)
Impeller Type		Opened
Shaft Seal		Double Mechanical Seal
		Silicon Carbide VS Ceramic / Carbon
Bearings		C3 Shielded ball bearings
Cable		PVC (CSA Certified) / H07RN-F
		6m (20ft) or longer upon request.
Materials	Pump Casing	Stainless Steel
	Impeller	Stainless Steel
	Motor Frame	Stainless Steel
	Motor Shaft	Stainless Steel
	Strainer	Stainless Steel
Max. Liquid Temperature		40°C (104°F)
Max. Submersion Depth		20m (66ft)
pH Range		pH 5 - pH 8

<input checked="" type="checkbox"/>	Simplex
<input type="checkbox"/>	Duplex
<input type="checkbox"/>	Triplex

<input checked="" type="checkbox"/>	OPTIONAL EQUIPMENT
<input type="checkbox"/>	Additional cable 30 □ 40 □ 50 □ 75 □ Ft.
<input type="checkbox"/>	Slide away coupling
<input type="checkbox"/>	Impeller trims
<input type="checkbox"/>	High Temp winding and seal liquids 190°F / 88°C





# SERIES FSS Dewatering Pump

SUBMITTAL DATA

50HZ

FSS-215

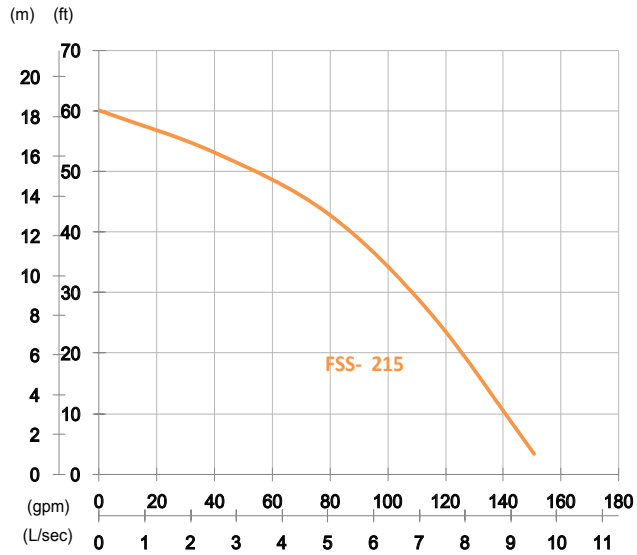

Shaft Speed : 2850 rpm

Outlet : 50mm, 2in

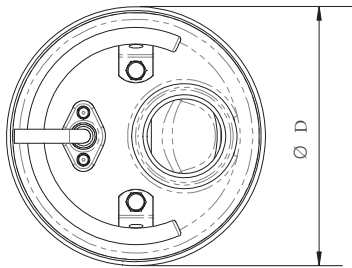

Dimensions	mm	in
A	449	17.7
B	399	15.7
C	94	3.7
D	186	7.3

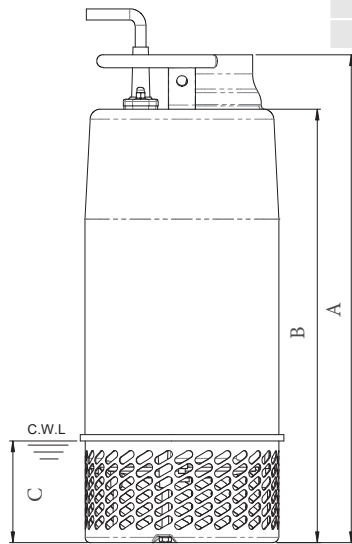

Weight : 19kg / 42 lbs

OUTPUT	HEAD	FLOW
1.5 kW	Rated : 13.1m, 43ft	Rated : 5 L/s, 79 gpm
2 HP	Max : 18.3m, 60ft	Max : 9.5 L/s, 150 gpm

Solid Passage : 7 mm, 0.3 in

Pump Type		Electric Submersible Pumps
		1-Phase, 3-Phase
Motor	Type	Induction Motor
	Insulation	Class F
	Protector	Circle Thermal Protector
	Starter	1-Phase · Capacitor-Run, 3-Phase · D.O.L.
Lubricant		Food Grade (ISO VG32)
Impeller Type		Closed
Shaft Seal		Double Mechanical Seal Silicon Carbide VS Ceramic / Carbon
Bearings		C3 Shielded ball bearings
Cable		PVC (CSA Certified) / H07RN-F 10m (33ft) or longer upon request.
Materials	Pump Casing	Stainless Steel
	Impeller	Stainless Steel
	Motor Frame	Stainless Steel
	Motor Shaft	Stainless Steel
	Strainer	Stainless Steel
Max. Liquid Temperature		40°C (104°F)
Max. Submersion Depth		20m (66ft)
pH Range		pH 5 - pH 8

<input checked="" type="checkbox"/>	Simplex
<input type="checkbox"/>	Duplex
<input type="checkbox"/>	Triplex

<input checked="" type="checkbox"/>	OPTIONAL EQUIPMENT
<input type="checkbox"/>	Additional cable 30 □ 40 □ 50 □ 75 □ Ft.
<input type="checkbox"/>	Slide away coupling
<input type="checkbox"/>	Impeller trims
<input type="checkbox"/>	High Temp winding and seal liquids 190°F / 88°C





FSS-315

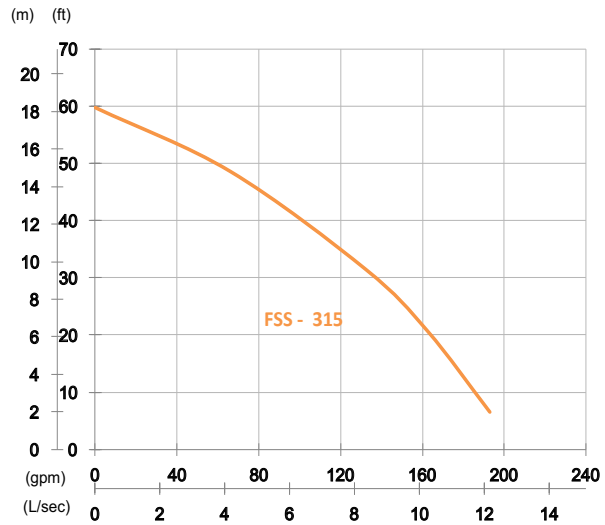

Shaft Speed : 2850 rpm

Outlet : 80mm, 3in

OUTPUT	HEAD	FLOW
1.5 kW	Rated : 9.6m, 31ft	Rated : 8.3 L/s, 132 gpm
2 HP	Max : 18.2m, 60ft	Max : 12.2 L/s, 193 gpm

Solid Passage : 7 mm, 0.3 in

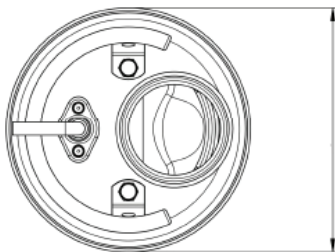

Dimensions	mm	in
A	449	17.7
B	399	15.7
C	94	3.7
D	186	7.3

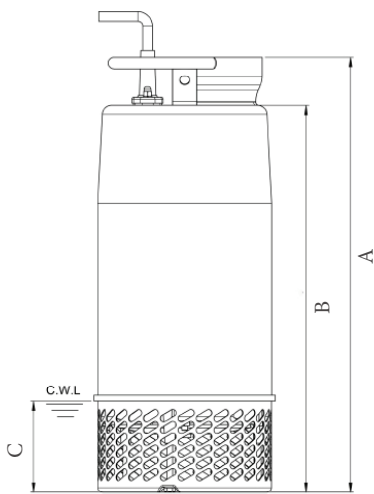

Weight : 19kg / 42 lbs

Pump Type		Electric Submersible Pumps
		1-Phase, 3-Phase
Motor	Type	Induction Motor
	Insulation	Class F
	Protector	Circle Thermal Protector
	Starter	1-Phase · Capacitor-Run, 3-Phase · D.O.L.
Lubricant		Food Grade (ISO VG32)
Impeller Type		Closed
Shaft Seal		Double Mechanical Seal Silicon Carbide VS Ceramic / Carbon
Bearings		C3 Shielded ball bearings
Cable		PVC (CSA Certified) / H07RN-F 10m (33ft) or longer upon request.
Materials	Pump Casing	Stainless Steel
	Impeller	Stainless Steel
	Motor Frame	Stainless Steel
	Motor Shaft	Stainless Steel
	Strainer	Stainless Steel
Max. Liquid Temperature		40°C (104°F)
Max. Submersion Depth		20m (66ft)
pH Range		pH 5 - pH 8

✓	
	Simplex
	Duplex
	Triplex

✓	OPTIONAL EQUIPMENT
	Additional cable 30 □ 40 □ 50 □ 75 □ Ft.
	Slide away coupling
	Impeller trims
	High Temp winding and seal liquids 190°F / 88°C



# SERIES FSH

SUBMITTAL DATA

## High Chrome Dewatering Pump

50HZ

FSH-6370

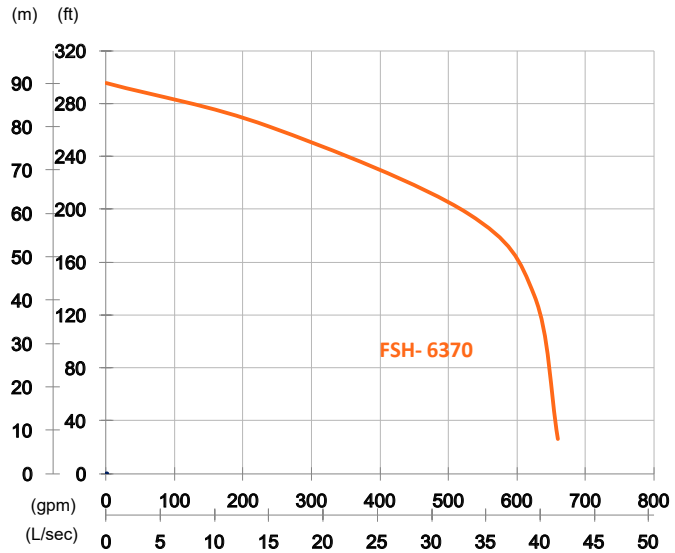

Shaft Speed : 2850 rpm

Outlet : 150mm, 6in

OUTPUT	HEAD	FLOW
37 kW	Rated : 60m, 197ft	Rated : 33.3 L/s, 528 gpm
50 HP	Max : 90m, 295ft	Max : 41.7 L/s, 660 gpm

Solid Passage : 10mm, 0.4in

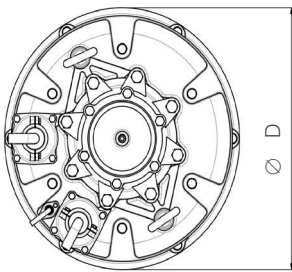

Dimensions	mm	in
A	-----	-----
B	1047	41.2
C	195	7.7
D	532	20.9

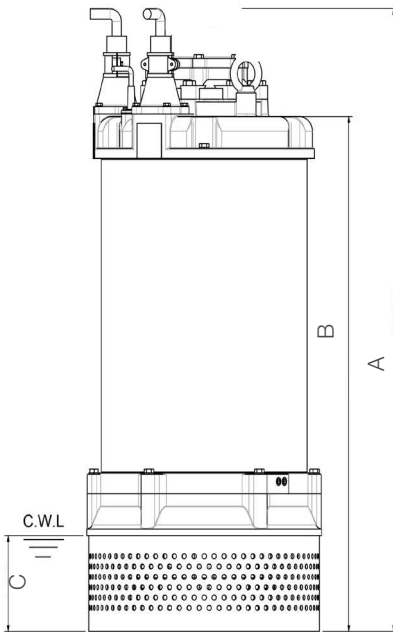

Weight : 510kg / 1124 lbs

Pump Type		Electric Submersible Pumps	
		3-Phase	
Motor	Type	Induction Motor	
	Insulation	Class F	
	Protector	D.O.L. • Circle Thermal Protector Star-Delta • Miniature Thermal Sensors	
	Starter	D.O.L. • Star-Delta	
Lubricant		Food Grade (ISO VG32)	
Impeller Type		Closed	
Shaft Seal		Double Mechanical Seal Silicon Carbide VS Ceramic / Carbon	
Bearings		C3 Shielded ball bearings	
Cable		PVC (CSA Certified) / H07BQ-F 10m (33ft) or longer upon request.	
Materials	Pump Casing	Ductile Iron	
	Impeller	Chromium Iron	
	Motor Frame	Gray Iron	
	Motor Shaft	Stainless Steel	
	Outer Case	Carbon Steel	
		Strainer	Carbon Steel
Max. Liquid Temperature		40°C (104°F)	
Max. Submersion Depth		20m (66ft)	
pH Range		pH 5 - pH 8	

<input checked="" type="checkbox"/>	Simplex	<input checked="" type="checkbox"/>	OPTIONAL EQUIPMENT
<input type="checkbox"/>	Duplex	<input type="checkbox"/>	Additional cable 30 □ 40 □ 50 □ 75 □ Ft.
<input type="checkbox"/>	Triplex	<input type="checkbox"/>	Slide away coupling
		<input type="checkbox"/>	Impeller trims
		<input type="checkbox"/>	High Temp winding and seal liquids 190°F / 88°C



# SERIES FSH

SUBMITTAL DATA

## High Chrome Dewatering Pump

50HZ

FSH-8370

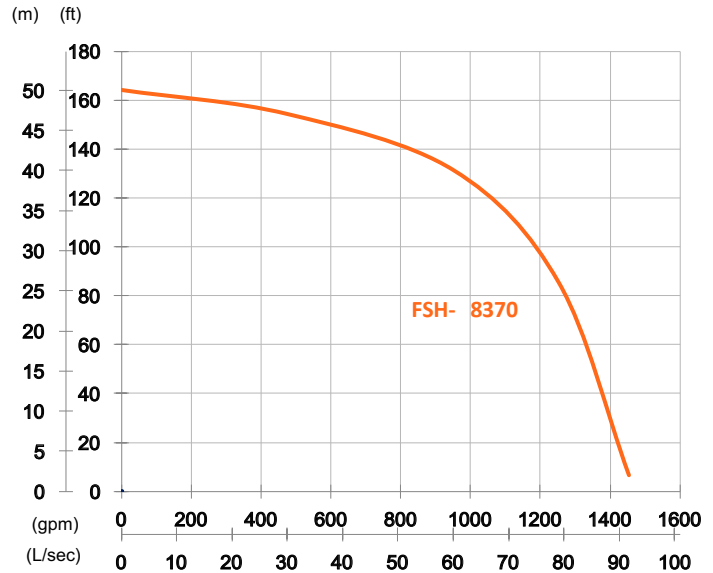

Shaft Speed : 2850 rpm

Outlet : 200mm, 8in

OUTPUT	HEAD	FLOW
37 kW	Rated : 40m, 131ft	Rated : 60 L/s, 950 gpm
50 HP	Max : 50m, 164ft	Max : 91.6 L/s, 1452 gpm

Solid Passage : 20 mm, 0.8 in

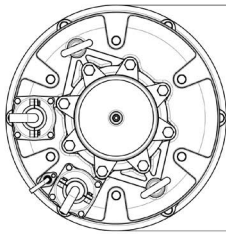

Dim.	mm	in
A	-----	-----
B	1047	41.2
C	195	7.7
D	532	20.9

Pump Type		Electric Submersible Pumps
		3-Phase
Motor	Type	Induction Motor
	Insulation	Class F
	Protector	D.O.L. • Circle Thermal Protector Star-Delta • Miniature Thermal Sensors
	Starter	D.O.L. • Star-Delta
Lubricant		Food Grade (ISO VG32)
Impeller Type		Closed
Shaft Seal		Double Mechanical Seal Silicon Carbide VS Ceramic / Carbon
Bearings		C3 Shielded ball bearings
Cable		PVC (CSA Certified) / H07BQ-F 10m (33ft) or longer upon request.
Materials	Pump Casing	Ductile Iron
	Impeller	Chromium Iron
	Motor Frame	Gray Iron
	Motor Shaft	Stainless Steel
	Outer Case	Carbon Steel
	Strainer	Carbon Steel
Max. Liquid Temperature		40°C (104°F)
Max. Submersion Depth		20m (66ft)
pH Range		pH 5 - pH 8

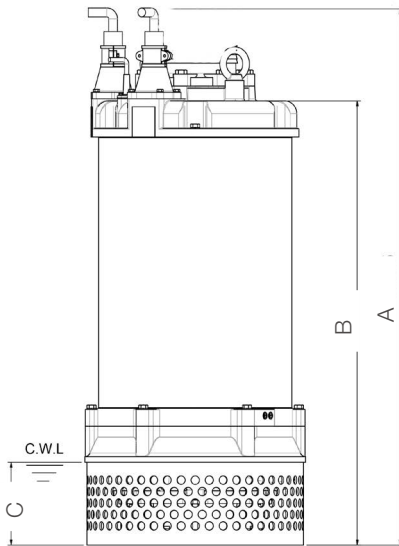

Weight : 510kg / 1124 lbs

✓	OPTIONAL EQUIPMENT
Simplex	Additional cable 30 □ 40 □ 50 □ 75 □ Ft.
Duplex	Slide away coupling
Triplex	Impeller trims
	High Temp winding and seal liquids 190°F / 88°C

FloFab is certified :



# SERIES FSH

SUBMITTAL DATA

## High Chrome Dewatering Pump

50HZ

FSH-6450

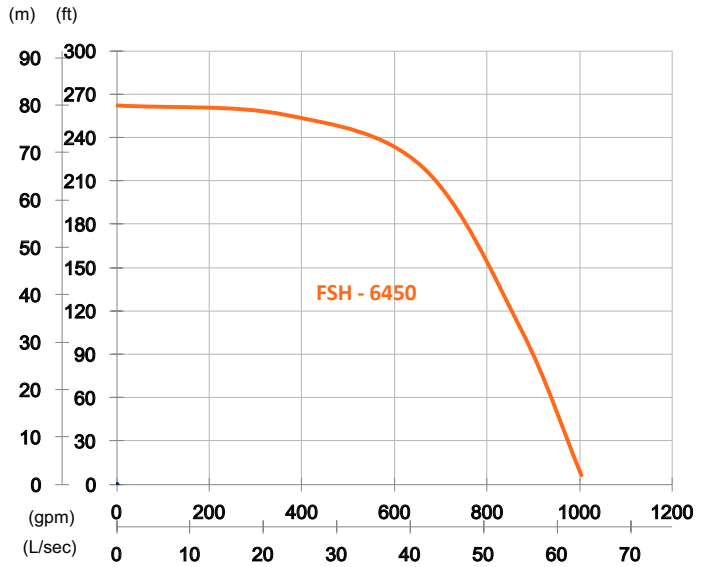

Shaft Speed : 2850 rpm

Outlet : 150mm, 6in

OUTPUT	HEAD	FLOW
45 kW	Rated : 68m, 223ft	Rated : 41.6 L/s, 660 gpm
60 HP	Max : 80m, 262ft	Max : 63.3 L/s, 1003 gpm

Solid Passage : 10 mm, 0.4 in

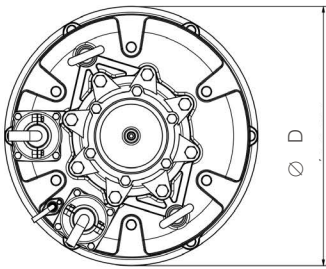

Dim.	mm	in
A	-----	-----
B	1047	41.2
C	195	7.7
D	532	20.9

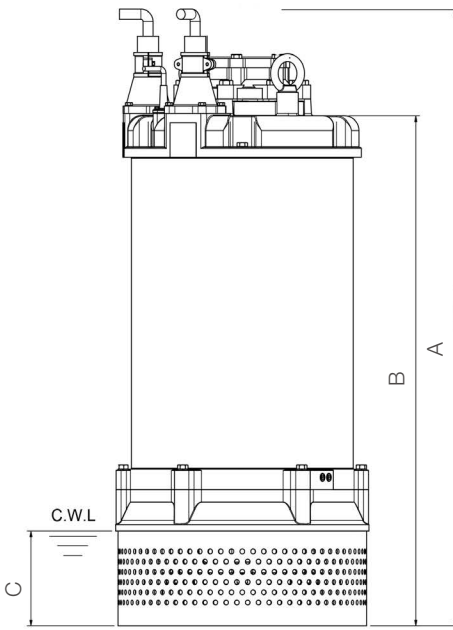

Weight : 530kg / 1168 lbs

Pump Type		Electric Submersible Pumps
		3-Phase
Motor	Type	Induction Motor
	Insulation	Class F
	Protector	Star-Delta • Miniature Thermal Sensors
	Starter	Star-Delta
Lubricant		Food Grade (ISO VG32)
Impeller Type		Closed
Shaft Seal		Double Mechanical Seal Silicon Carbide VS Ceramic / Carbon
Bearings		C3 Shielded ball bearings
Cable		PVC (CSA Certified) / H07BQ-F 10m (33ft) or longer upon request.
Materials	Pump Casing	Ductile Iron
	Impeller	Chromium Iron
	Motor Frame	Gray Iron
	Motor Shaft	Stainless Steel
	Outer Case	Carbon Steel
	Strainer	Carbon Steel
Max. Liquid Temperature		40°C (104°F)
Max. Submersion Depth		20m (66ft)
pH Range		pH 5 - pH 8

<input checked="" type="checkbox"/>		<input checked="" type="checkbox"/>	OPTIONAL EQUIPMENT
<input type="checkbox"/>	Simplex	<input type="checkbox"/>	Additional cable 30 □ 40 □ 50 □ 75 □ Ft.
<input type="checkbox"/>	Duplex	<input type="checkbox"/>	Slide away coupling
<input type="checkbox"/>	Triplex	<input type="checkbox"/>	Impeller trims
		<input type="checkbox"/>	High Temp winding and seal liquids 190°F / 88°C

FloFab is certified :



# SERIES FSH

SUBMITTAL DATA

## High Chrome Dewatering Pump

50HZ

FSH-8450

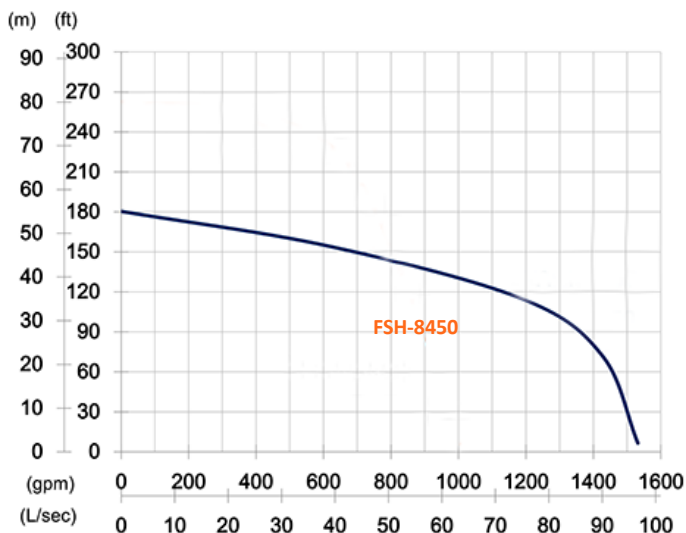

Shaft Speed : 2850 rpm

Outlet : 200mm, 8in

OUTPUT	HEAD	FLOW
45 kW	Rated : 35m, 115ft	Rated : 75 L/s, 1188 gpm
60 HP	Max : 55m, 180ft	Max : 96.6 L/s, 1531 gpm

Solid Passage : 20mm, 0.8in

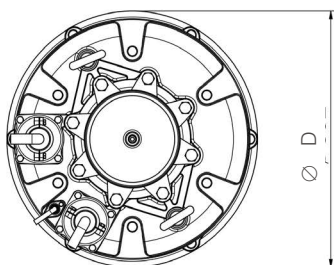

Dim.	mm	in
A	-----	-----
B	1047	41.2
C	195	7.7
D	532	20.9

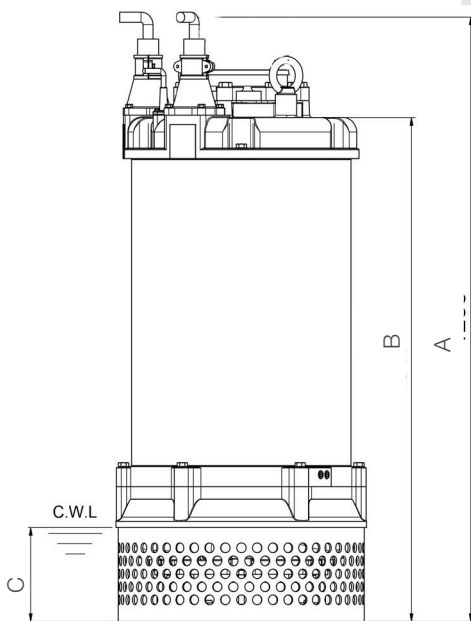

Weight : 530kg / 1168 lbs

Pump Type		Electric Submersible Pumps
		3-Phase
Motor	Type	Induction Motor
	Insulation	Class F
	Protector	Star-Delta • Miniature Thermal Sensors
	Starter	Star-Delta
Lubricant		Food Grade (ISO VG32)
Impeller Type		Closed
Shaft Seal		Double Mechanical Seal Silicon Carbide VS Ceramic / Carbon
Bearings		C3 Shielded ball bearings
Cable		PVC (CSA Certified) / H07BQ-F 10m (33ft) or longer upon request.
Materials	Pump Casing	Ductile Iron
	Impeller	Chromium Iron
	Motor Frame	Gray Iron
	Motor Shaft	Stainless Steel
	Outer Case	Carbon Steel
	Strainer	Carbon Steel
Max. Liquid Temperature		40°C (104°F)
Max. Submersion Depth		20m (66ft)
pH Range		pH 5 - pH 8

✓	OPTIONAL EQUIPMENT
Simplex	Additional cable 30 □ 40 □ 50 □ 75 □ Ft.
Duplex	Slide away coupling
Triplex	Impeller trims
	High Temp winding and seal liquids 190°F / 88°C

FloFab is certified :



# SERIES SLIM Dewatering Pump

SUBMITTAL DATA

50HZ

SLIM-380

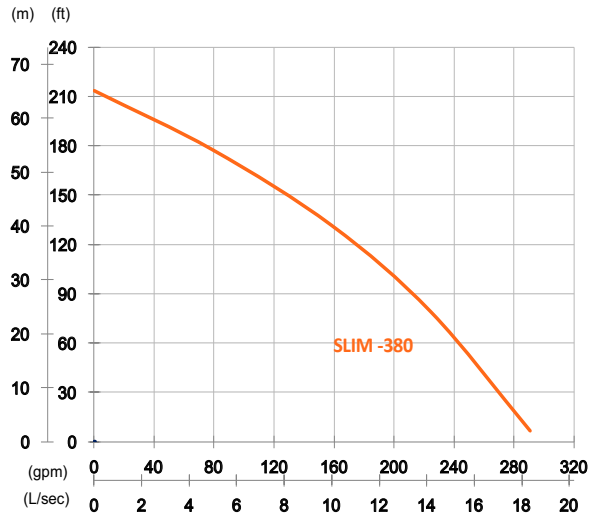

Shaft Speed : 2850 rpm

Outlet : 80mm, 3in

OUTPUT	HEAD	FLOW
8 kW	Rated : 40m, 131ft	Rated : 10 L/s, 158 gpm
11 HP	Max : 65m, 213ft	Max : 18.3 L/s, 290 gpm

Solid Passage : 8mm, 0.3in

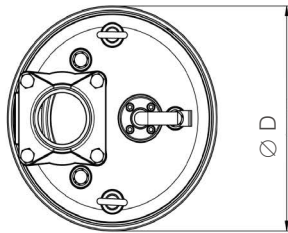

Dim.	mm	in
A	-----	-----
B	663	26.1
C	200	7.9
D	283	11.1

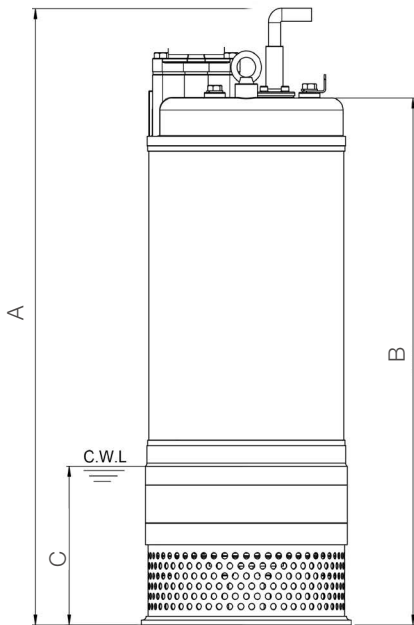

Weight : 92kg / 203 lbs

Pump Type		Electric Submersible Pumps
		3-Phase
Motor	Type	Induction Motor
	Insulation	Class F
	Protector	Circle Thermal Protector
	Starter	D.O.L.
Lubricant		Food Grade (ISO VG32)
Impeller Type		Opened • Dual impellers
Shaft Seal		Double Mechanical Seal
		Silicon Carbide VS Ceramic / Carbon
Bearings		C3 Shielded ball bearings
Cable		PVC (CSA Certified) / H07BQ-F
		10m (33ft) or longer upon request.
Materials	Pump Casing	Gray Iron
	Impeller	Chromium Iron
	Motor Frame	Stainless Steel
	Motor Shaft	Stainless Steel
	Outer Case	Stainless Steel
	Strainer	Stainless Steel
Max. Liquid Temperature		40°C (104°F)
Max. Submersion Depth		20m (66ft)
pH Range		pH 5 - pH 8

✓		✓	OPTIONAL EQUIPMENT
	Simplex		Additional cable 30 □ 40 □ 50 □ 75 □ Ft.
	Duplex		Slide away coupling
	Triplex		Impeller trims
			High Temp winding and seal liquids 190°F / 88°C

FloFab is certified :



# SERIES FLS

SUBMITTAL DATA

## High Chrome Dewatering Pump

50HZ

FLS-400

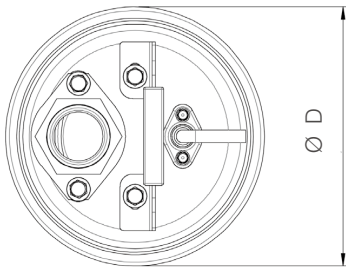

Dimensions	mm	in
A	336	13.2
B	249	9.8
C	2	0.1
D	206	8.1

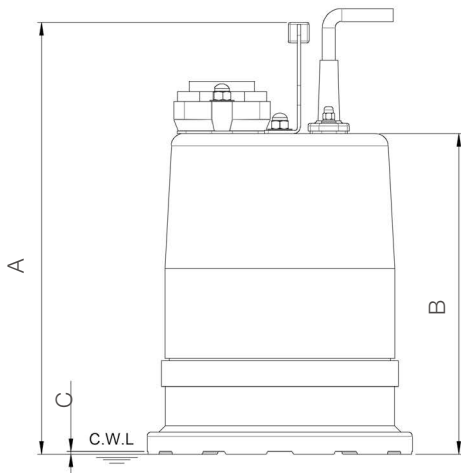

Weight : 14kg / 31 lbs

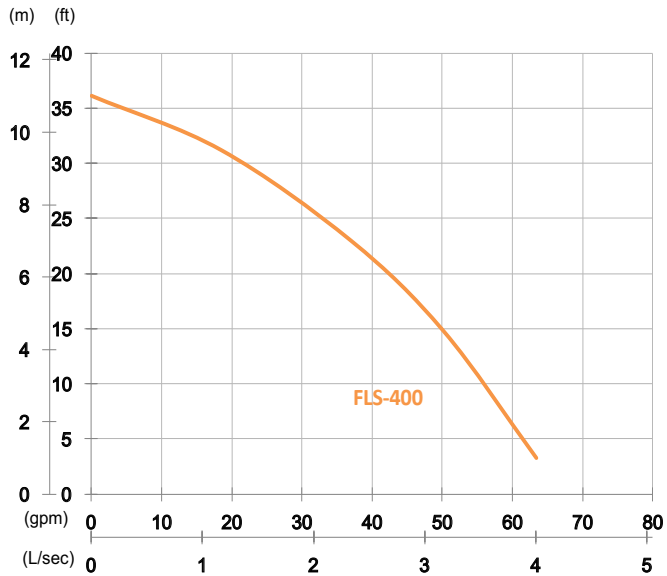

Shaft Speed : 2850 rpm

Outlet : 50mm, 2in

OUTPUT	HEAD	FLOW
0.4 kW	Rated : 7m, 23ft	Rated : 2.3 L/s, 37 gpm
0.5 HP	Max : 11m, 36ft	Max : 4 L/s, 63 gpm

Solid Passage : 2mm, 0.1in

Pump Type		Electric Submersible Pumps
		1-Phase
Motor	Type	Induction Motor
	Insulation	Class F
	Protector	Circle Thermal Protector
	Starter	1-Phase • Capacitor-Run
Lubricant		Food Grade (ISO VG32)
Impeller Type		Opened
Shaft Seal		Double Mechanical Seal Silicon Carbide VS Ceramic / Carbon
Bearings		C3 Shielded ball bearings
Cable		PVC (CSA Certified) / H07RN-F 6m (20ft) or longer upon request.
Materials	Pump Casing	Gray Iron
	Impeller	Synthetic Polymers
	Motor Frame	Stainless Steel
	Motor Shaft	Stainless Steel
	Outer Case	Stainless Steel
Bottom Plate		Synthetic Rubber
Max. Liquid Temperature		40°C (104°F)
Max. Submersion Depth		20m (66ft)
pH Range		pH 5 - pH 8

✓	OPTIONAL EQUIPMENT
Simplex	Additional cable 30 □ 40 □ 50 □ 75 Ft.
Duplex	Slide away coupling
Triplex	Impeller trims
	High Temp winding and seal liquids 190°F / 88°C

FloFab is certified :

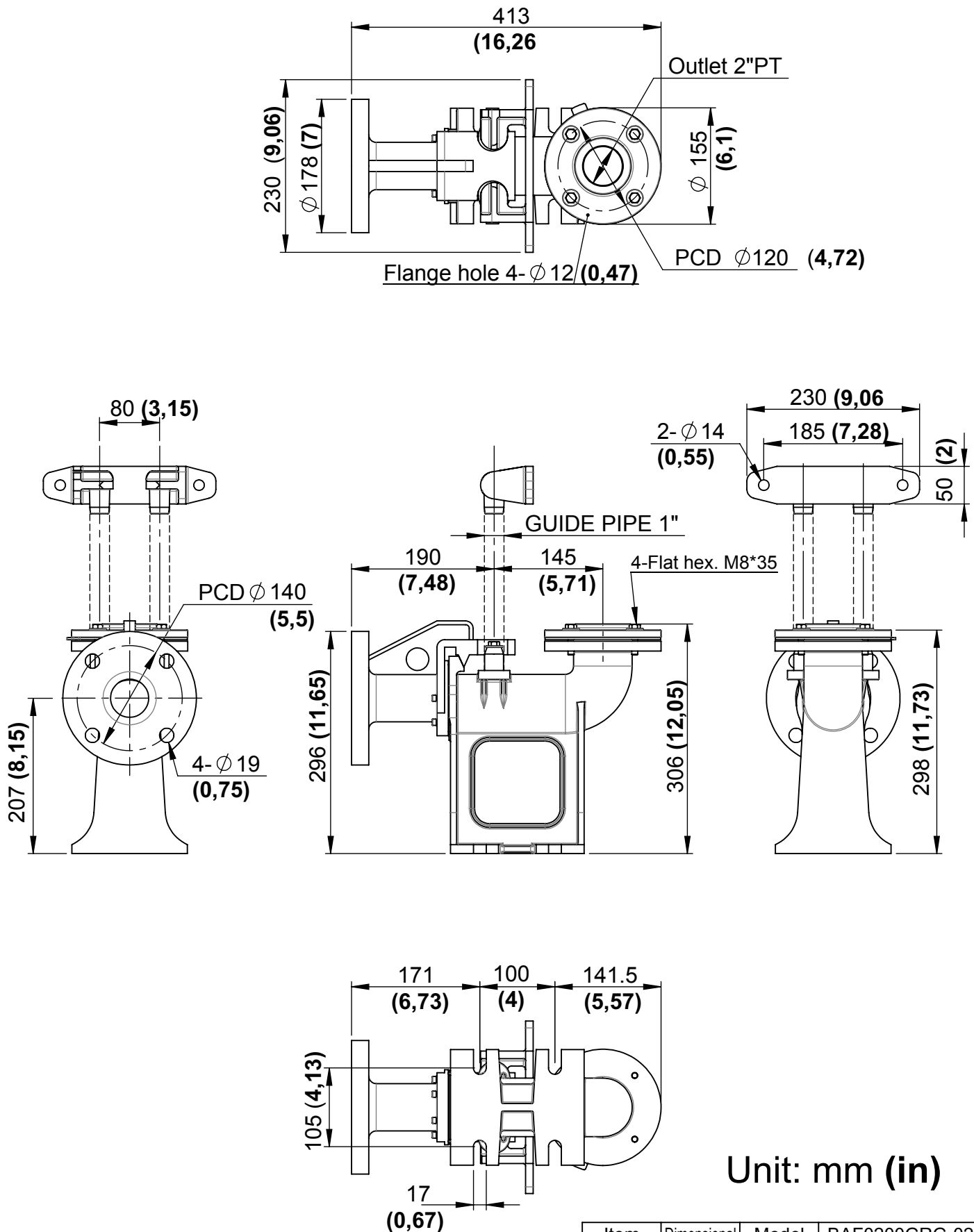

Unit: mm (in)

**Applicable Models:**  
FGC-37/55

Item	Dimensional	Model	BAF0200GRG-02
Drawn	QWS	Scale	1:7
Date	2014/04/14		
Rev.	A		



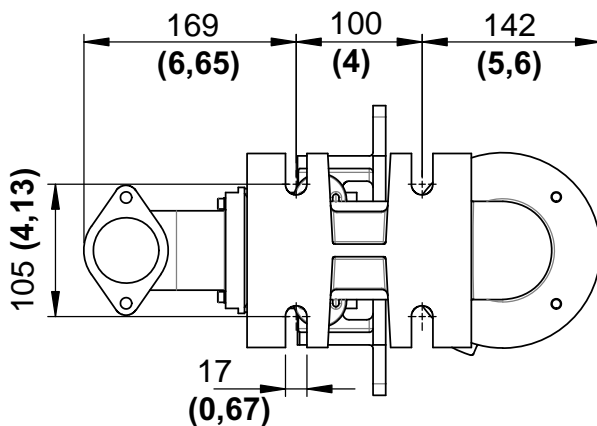
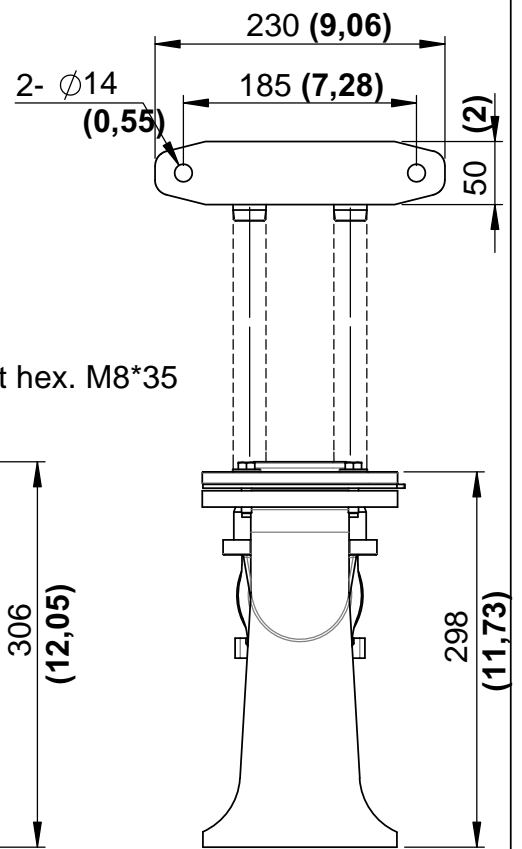
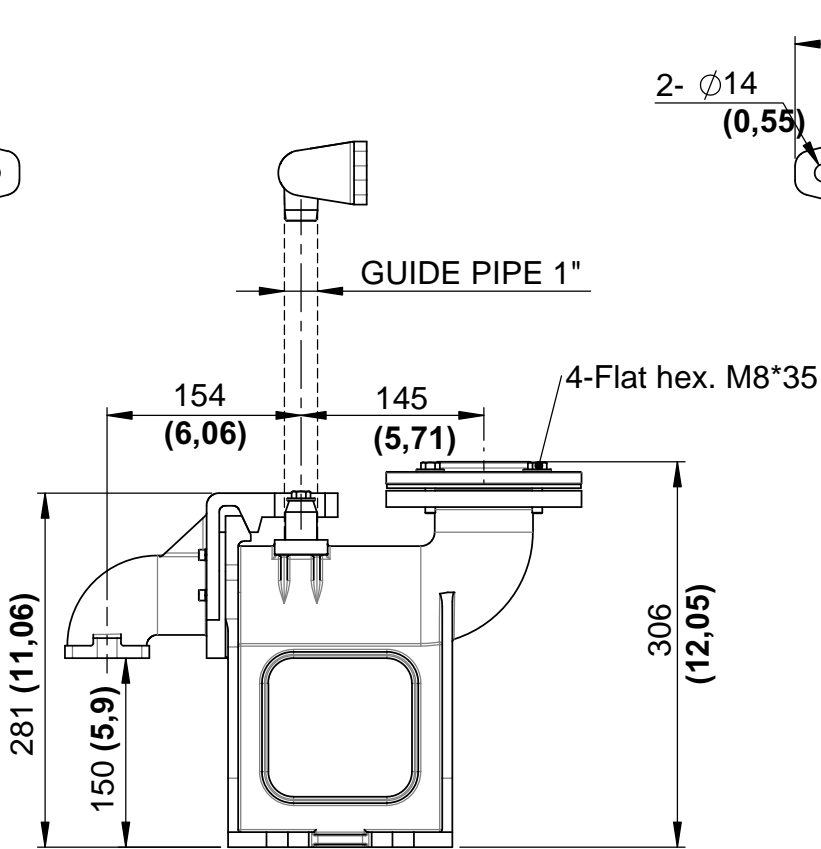
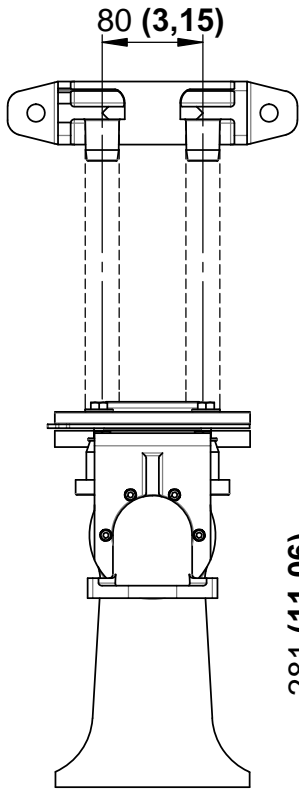
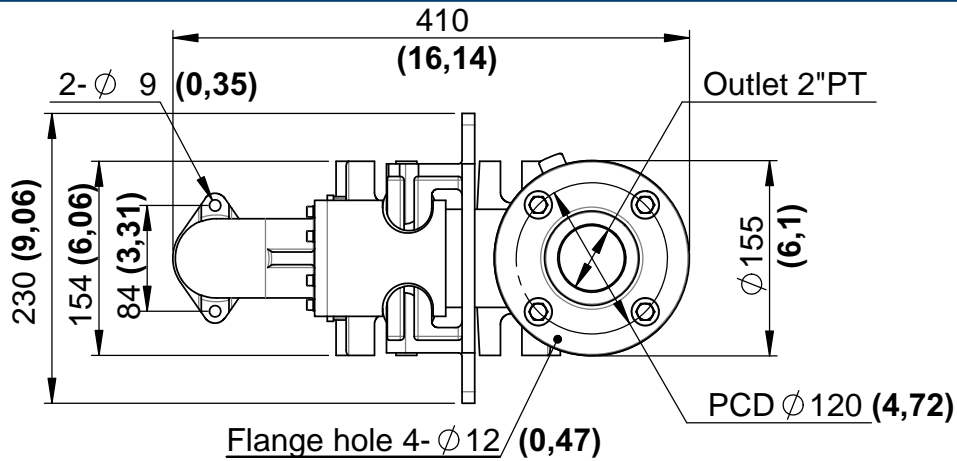

Unit: mm (in)

**Applicable Models:**  
FGC-11/15/22

Item	Dimensional	Model	BAF0200GRL-02
Drawn	QWS	Scale	1:6
Date	2014/04/14		
Rev.	A		

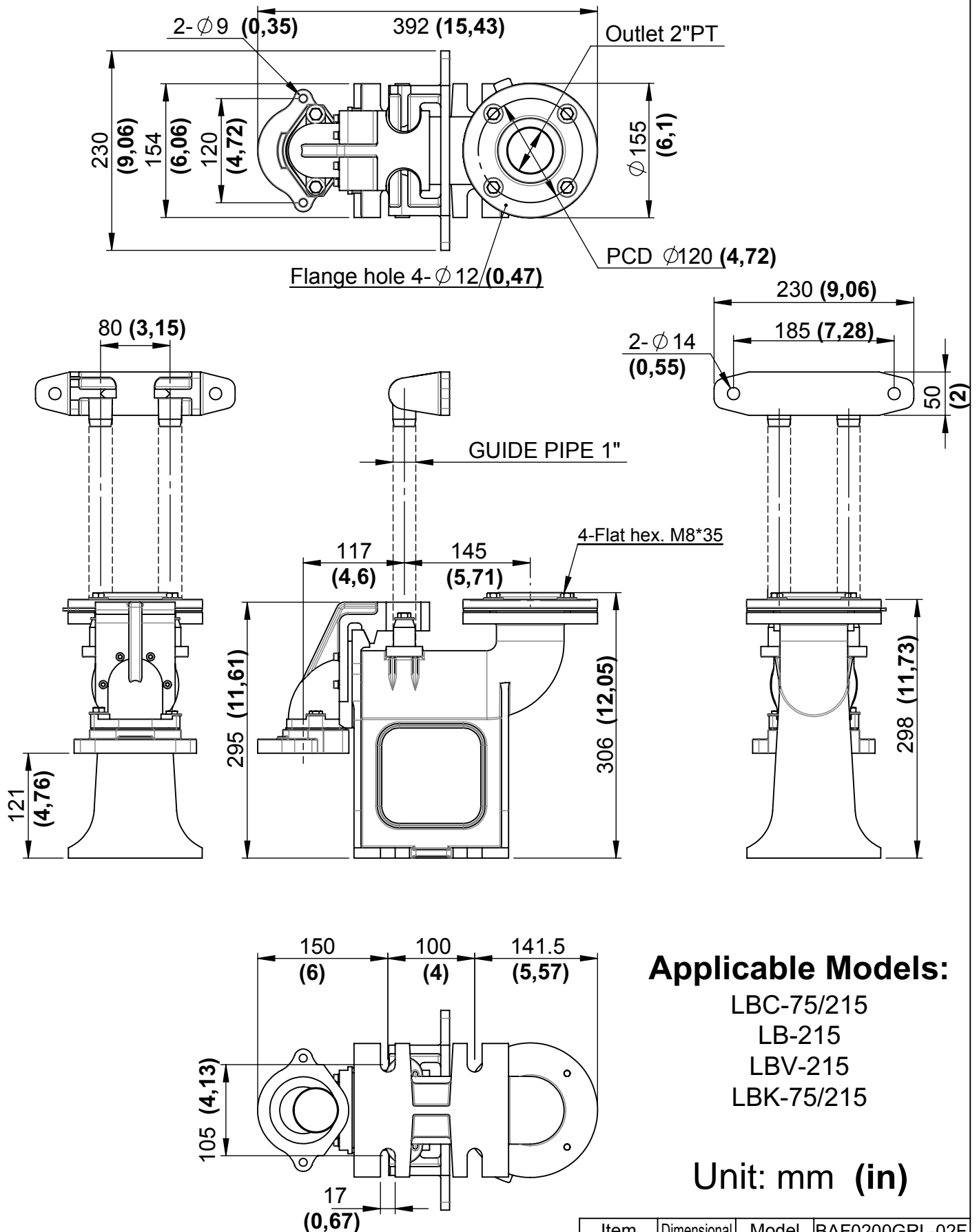

### Applicable Models:

- LBC-75/215
- LB-215
- LBV-215
- LBK-75/215

Unit: mm (in)

Item	Dimensional	Model	BAF0200GRL-02F
Drawn	QWS	Scale	1:6
Date	2014/04/14		
Rev.	A		

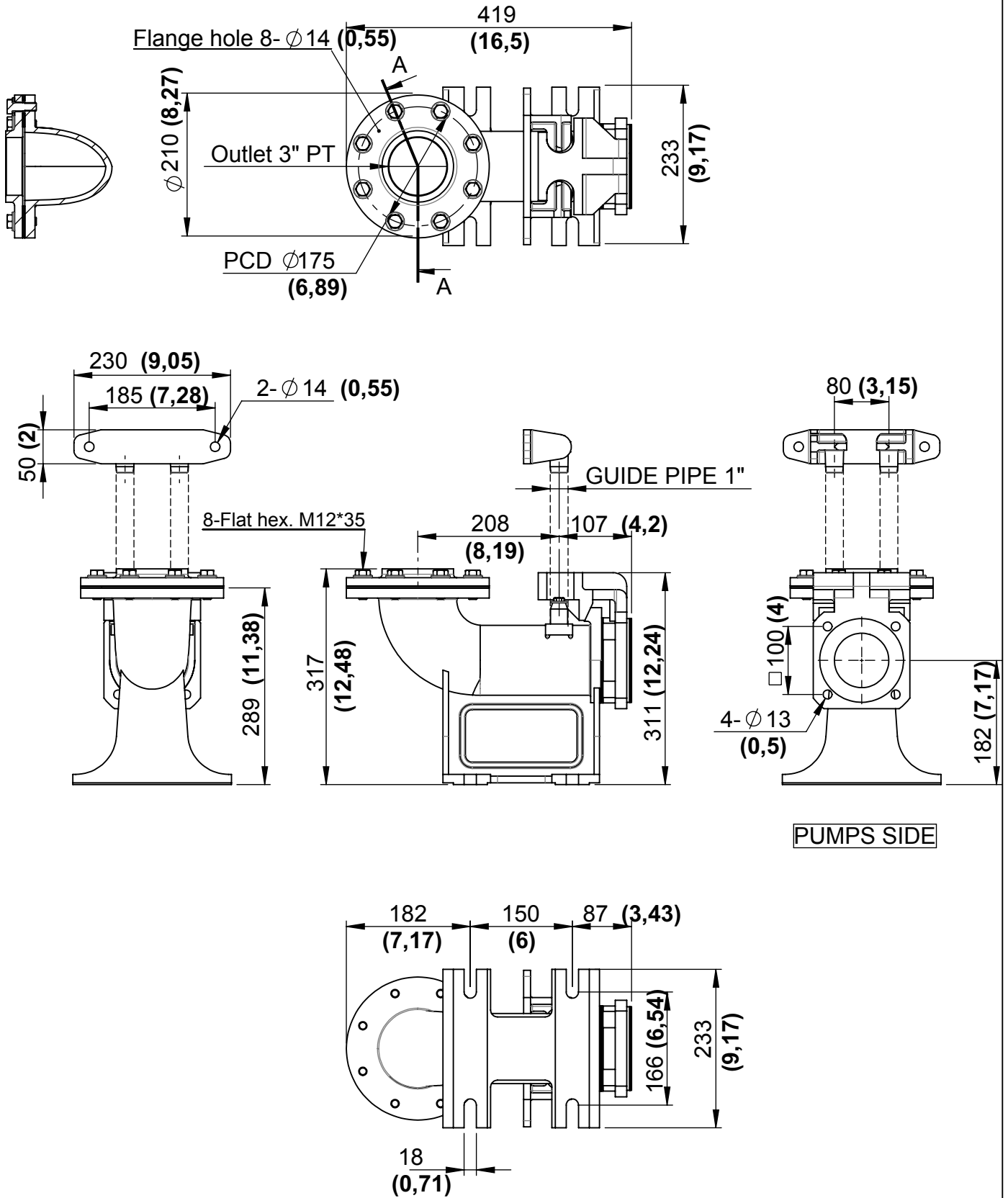

### Applicable Models:

FBC-322/337

FBV-322/337

FBK-322/337

Unit: mm (in)

Item	Dimensional	Model	BAF0300GRF-03
Drawn	QWS	Scale	1:8
Date	2014/04/11		
Rev.	A		



# GUIDE RAIL

## Model BAF0300GRL-03

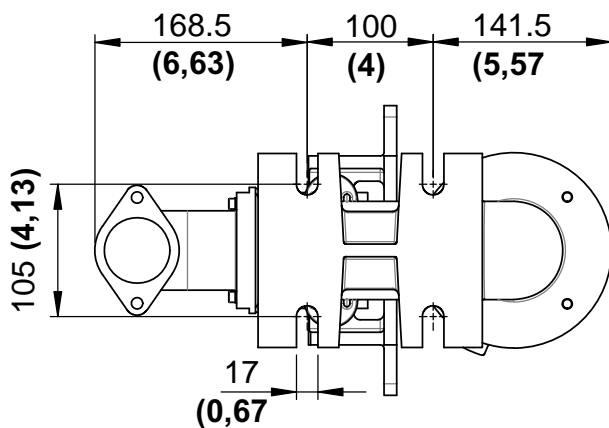
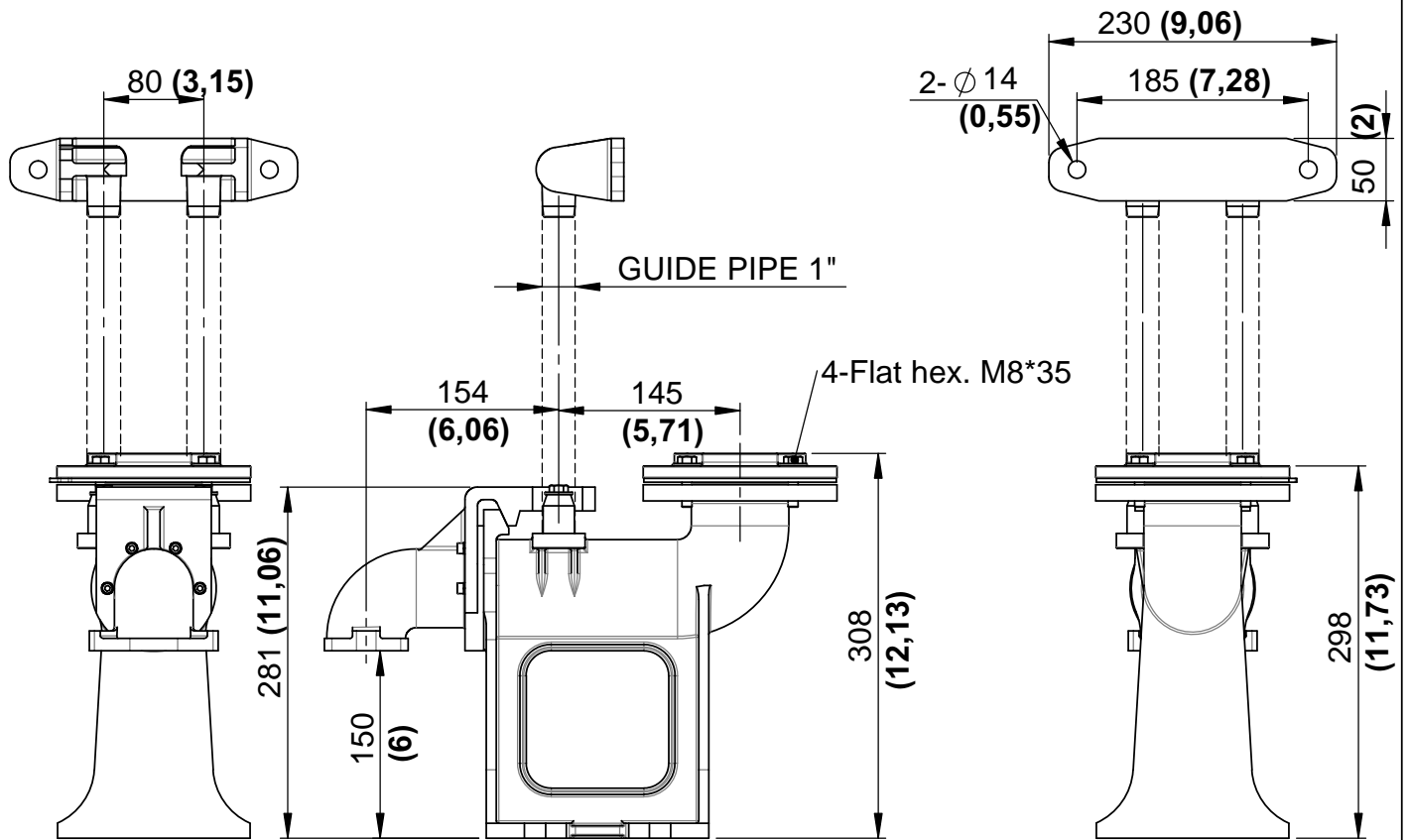
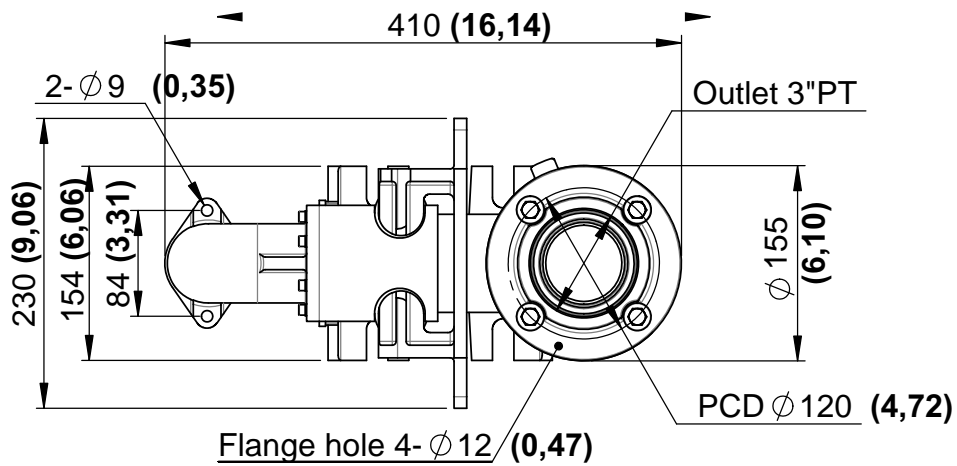

Unit: mm (in)

Item	Dimensional	Model	BAF0300GRL-03
Drawn	QWS	Scale	1:6
Date	2016/04/14		
Rev.	A		

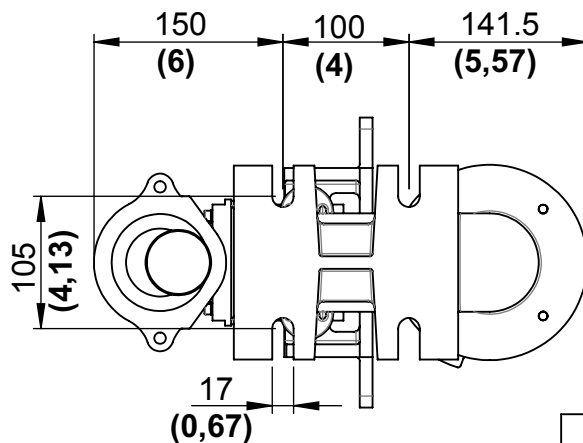
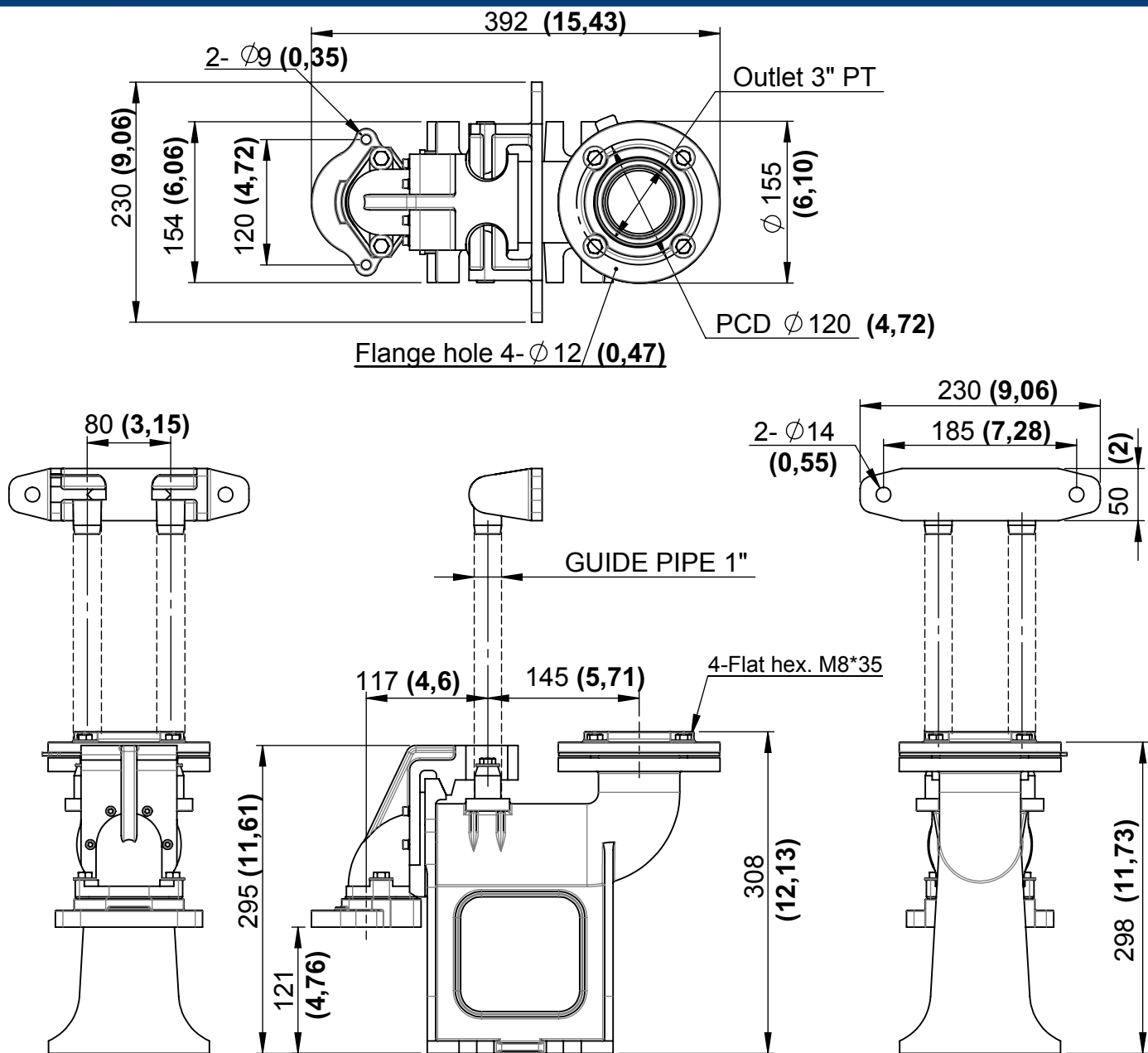

### Applicable Models:

- LBC-315
- LB-315
- LBV-315
- LBK-315

Unit: mm (in)

Item	Dimensional	Model	BAF0300GRL-03F
Drawn	QWS	Scale	1:6
Date	2014/04/15		
Rev.	A		

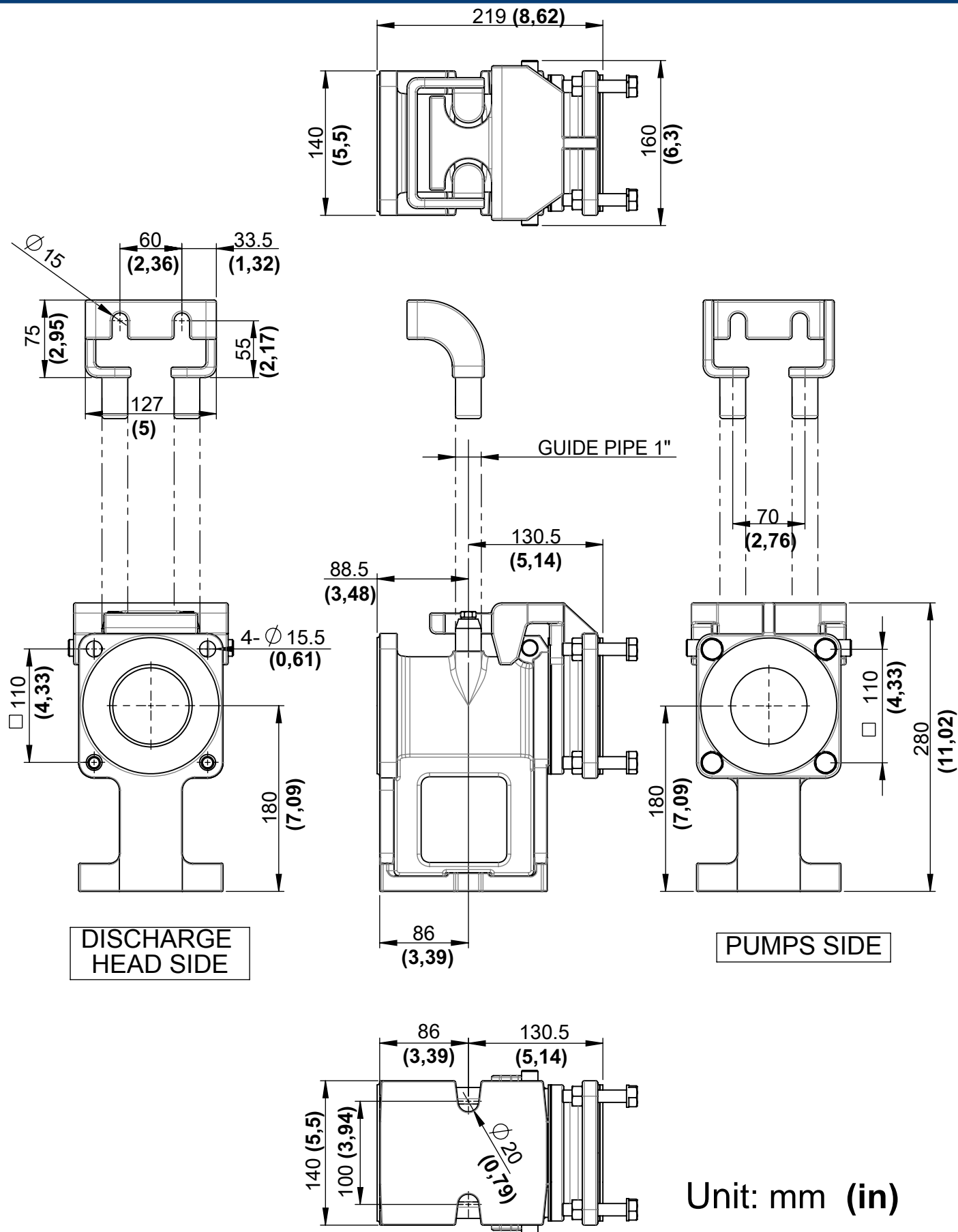

**Applicable Models:**  
FNC-337/437

Item	Dimensional	Model	BAF0300GRN-03
Drawn	QWS	Scale	1:5
Date	2014/04/01		
Rev.	A		

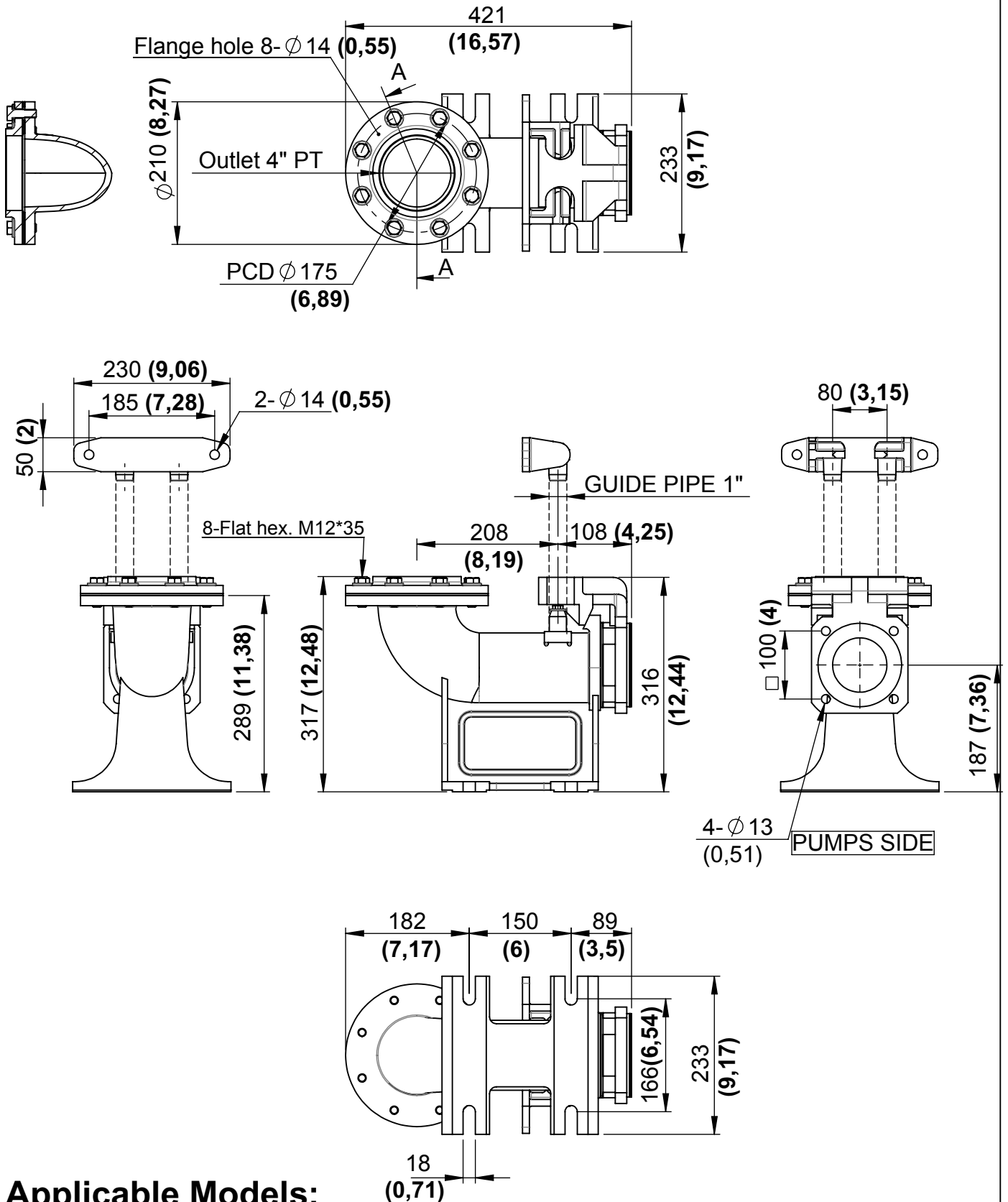

### Applicable Models:

FBC-437/455/475  
 FBV-437/455/475  
 FBK-437/455/475

Unit: mm (in)

Item	Dimensional	Model	BAF0400GRF-04
Drawn	QWS	Scale	1:8
Date	2014/04/11		
Rev.	A		

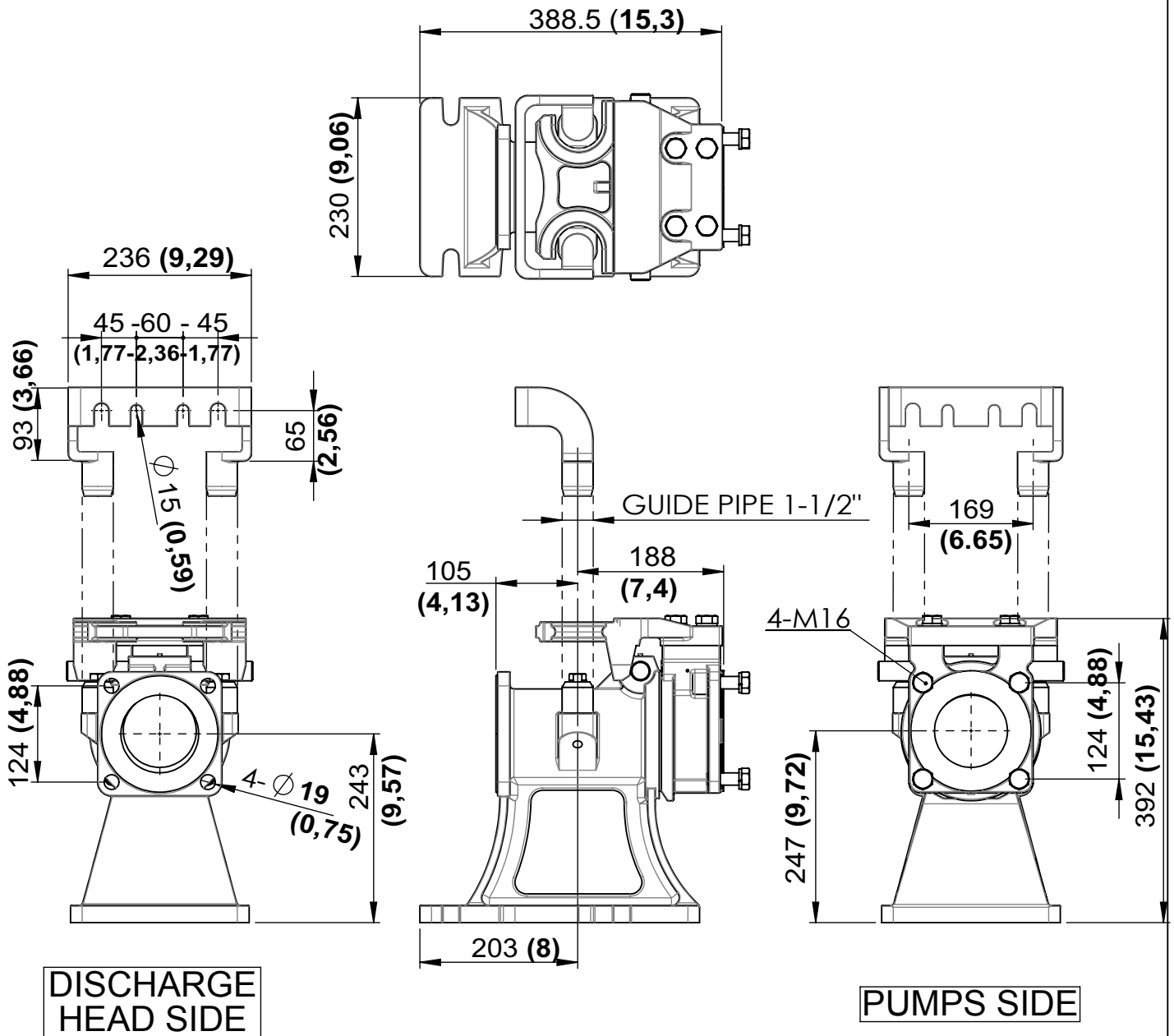

### Applicable Models:

FNC-455/655  
 FNC-475/675  
 FNC-4110/6110  
 FNC-4150/6150  
 FNC-4220/6220

Unit: mm (in)

Item	Dimensional	Model	BAF0400GRN-04
Drawn	QWS	Scale	1:8
Date	2014/04/07		
Rev.	A		



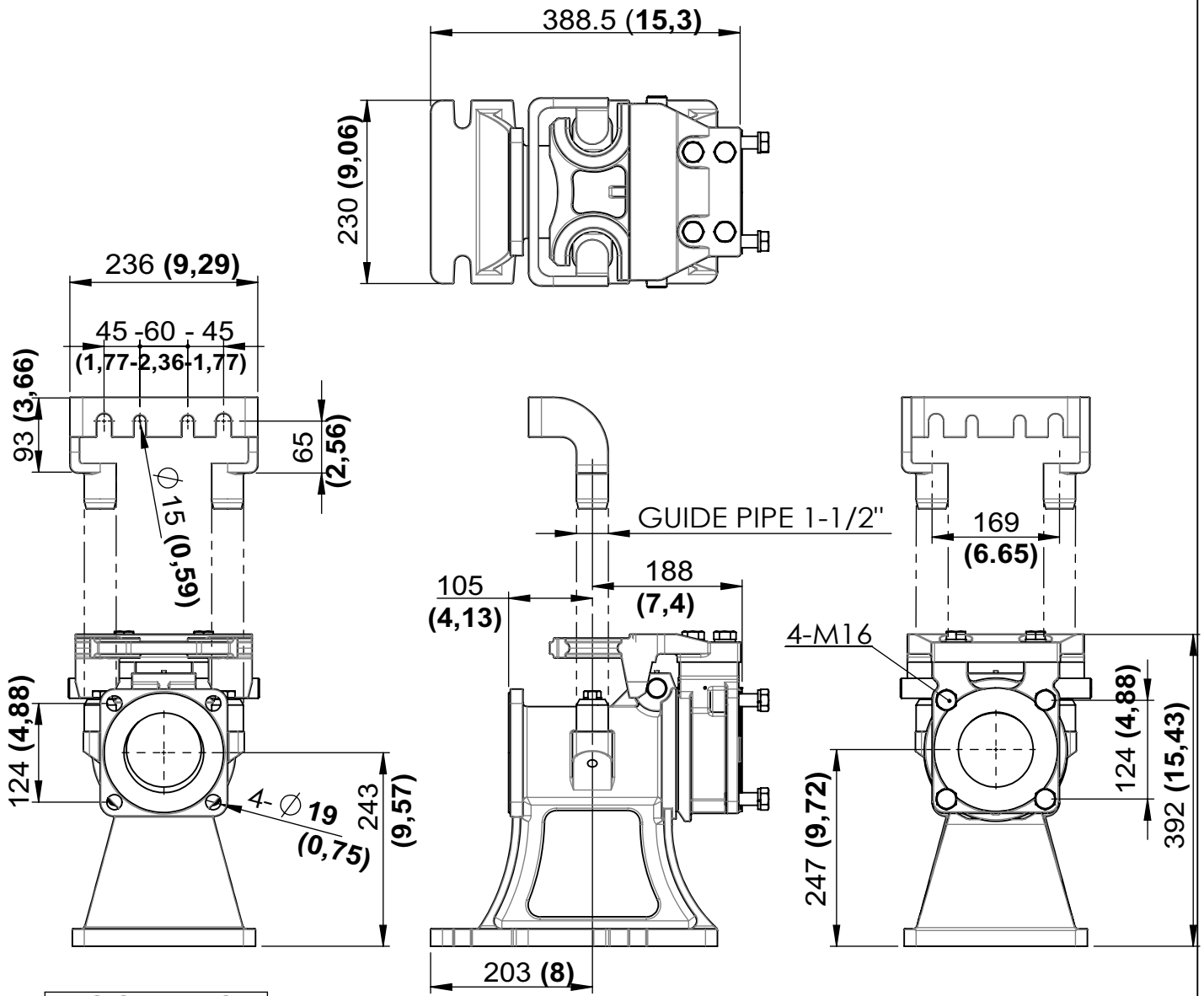

DISCHARGE  
HEAD SIDE

PUMPS SIDE

Unit: mm (in)

### Applicable Models:

FNC-4110  
FNC-6150

Item	Dimensional	Model	BAF0400GRN-04
Drawn	QWS	Scale	1:8
Date	2014/04/07		
Rev.	A		

## ● Slide Away Coupling :

Dimension may vary depending on the size of pump

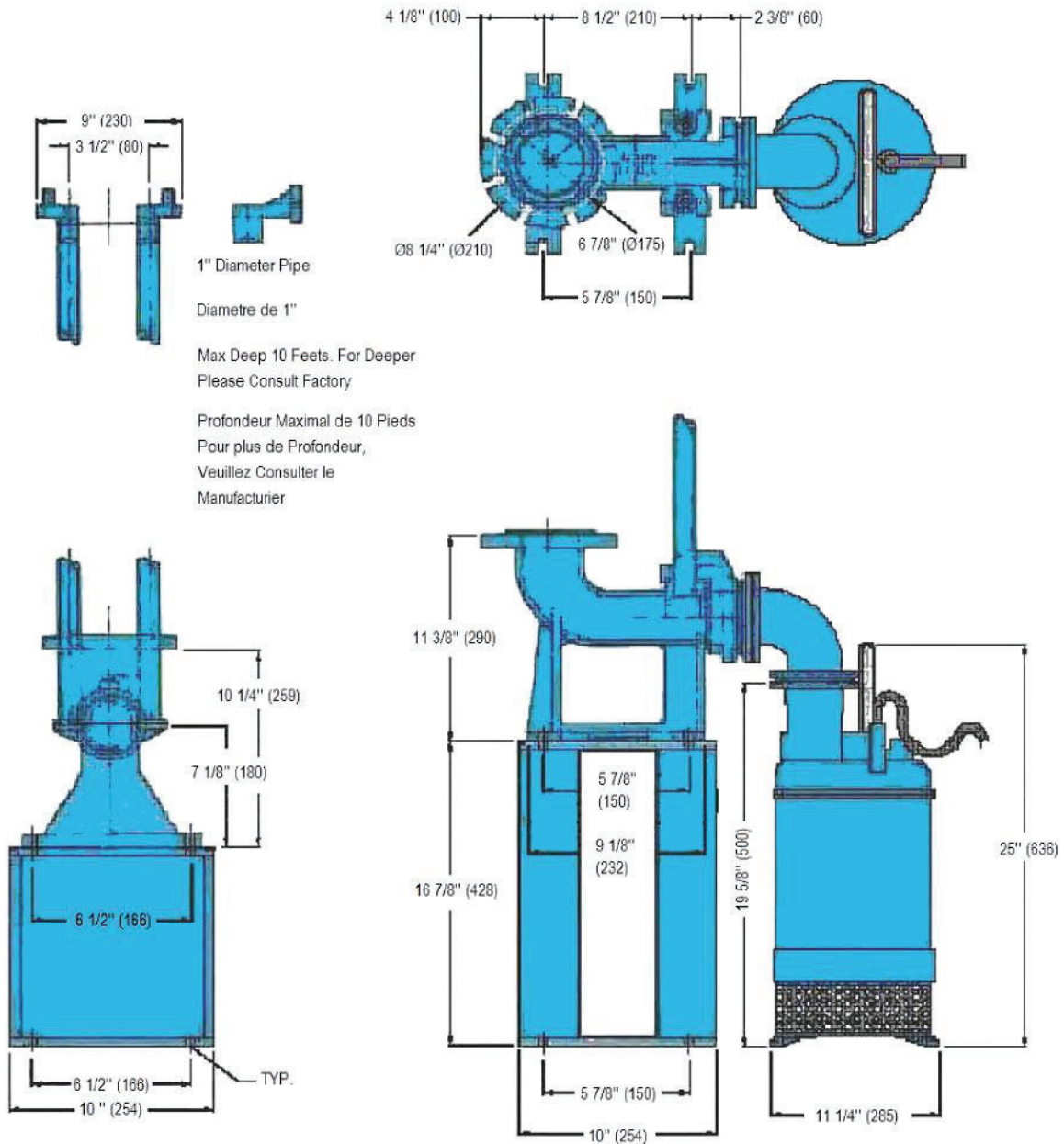

- FS - 3" Model BAFFS0300
- FS - 4" Model BAFFS0400
- FS - 6" Model BAFFS0600

## Mechanical Float Switch



Models/ Modèles	Cable/Câble		Contacts
	ft (pi)	Size Grandeur	
720163 (NF10W1500)	15	16/2	NO
720164 (NF10W2000)	20	16/2	NO
720165 (NF10W3000)	30	16/2	NO
720166 (NF10W5000)	50	16/2	NO
720167 (NF10W8000)	80	16/2	NO
720168 (NF10W9900)	100	16/2	NO
720175 (NWDW1500)	15	16/2	NO
720176 (NWDW2000)	20	16/2	NO
720177 (NWDW3000)	30	16/2	NC
720178 (NWDW5000)	50	16/2	NC
720179 (NWDW8000)	80	16/2	NC
720140 (GGIDW2000)	20	16/2	NO/NC
720144 (GGIDW3000)	30	16/3	NO/NC
720142 (GGIDW5000)	50	16/3	NO/NC
720143 (GGIDW8000)	80	16/3	NO/NC
720141 (GGIDW9900)	100	16/3	NO/NC

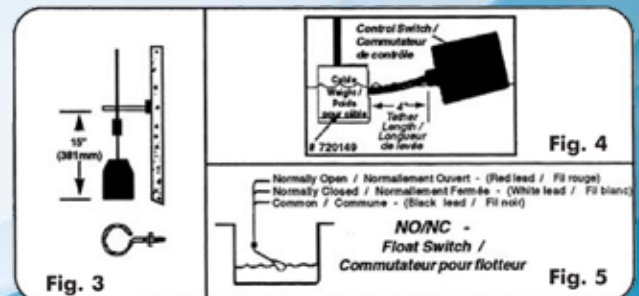
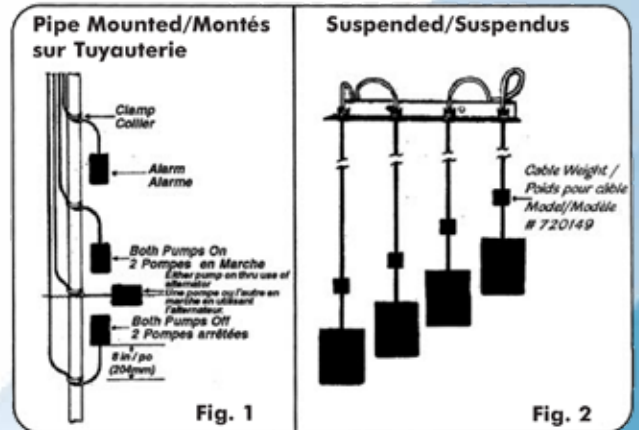

### Operating Characteristics

Switch operates with float level. Differential angle between ON and OFF is approximately 25° for either NORMALLY OPEN (NO) or NORMALLY CLOSED (NC) and 90° for double throw mechanical floats (NO/NC).

**Installation:** Either pipe mounted or suspended. For suspended application order cable weight #720149.

**Electric Rating:** 10A-115/230V AC

**Float:** High Impact Polystyrene

**Cable:** 16/2 "SJOW" NO or NC - 16/3 "SJOW" NO/NC

**Temperature:** 140°F (60°C)

- Never work in the sump with the pump ON
- Attach the level control to the mounting pipe or the pump discharge pipe.
- For suspended installations see fig.2 and fig.4
- Arrange the level controls so they do not tangle or hang up

**NOTE:** All liquid level controls are pilot duty devices which control the function of motor load devices, such as contactors, motor starters, and power relays, to automatically cycle a pump(s). They can also be used for alarm signaling devices. They cannot be used to directly power pump motors. Also do not use floats in gasoline or other combustible. Sway rings are recommended to be used in lift station where direct turbulence from incoming sewage may snarl or tangle the float cables. See fig.3



## Mercury Bulb Control

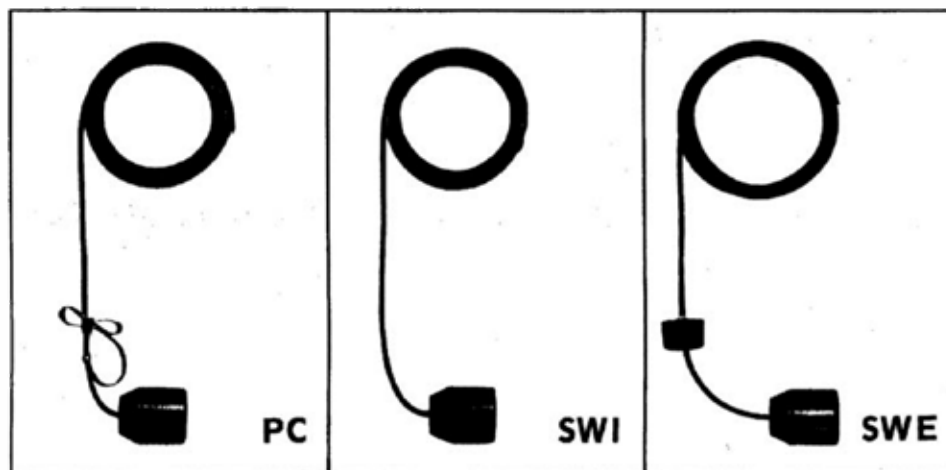

### Features

-Three models available: PC (Pipe Clamp)  
SWI (Internal Weight)  
SWE (External Weight)

- Single pole, heavy duty mercury tilt switch is epoxy encapsulated in non-corrosive, plastic float
- Entire unit (control as well as cord set) UL listed and CSA approved
- Two year limited warranty

### Application

Sensor floats may be used to activate pump control panels, solenoids, and relays. This liquid level control is frequently used in sewage systems, irrigation systems, and in other water systems.

### Description

All sensor float models are rated 13 amps (120V AC). Both the heavy duty, mercury activated tilt switch and the cord conductors are epoxy sealed in a watertight, impact resistant float housing. The mercury tilt switch activates when the float is a few degrees above or below the horizontal position.

### Specification

Models: NORMALLY OPEN 10PCNO, 10SWINO, 10SWENO  
NORMALLY CLOSED 10PCNC, 10SWINC, 10SWENC

**NOTE:**Numbers preceding model designation (PC, SWI, SWE) refer to cable length. the sensor float control switch is available in standard length of 10, 15, 20, 30, 40 and 50 ft. Other length available on request.

**Cable:** Water-resistant, Neoprene, Flex. 16 gauge, 2 conductors "SJOW" UL and CSA approved.

**Electrical Rating:** 13 amp 120/230V AC

**Float:** 3.18" dia. x 3.875" long, high impact resistant, noncorrosive PVC for use in liquids up to 140°F (60°C)

**External weight:** 2lbs of cast iron

**Mercury Tilt Switch:** Mercury to Mercury contacts



## Mercury Bulb Control

**NORMALLY OPEN (pump down):** The mercury float switch closes (Turns ON) when the float tips a few degrees above the horizontal position and opens (Turns OFF) when the float drops a few degrees under the horizontal position.

**NORMALLY CLOSED (pump up):** The mercury float switch closes (Turns ON) when the float drops a few degrees under the horizontal position and opens (Turns OFF) when the float tips a few degrees over the horizontal position.

- 1) Determine activation level
- 2) Strap sensor float control switch to discharge pipe or similar mounting at determined activation level. See illustration. The activation level may be adjusted by moving the pipe clamp up or down on the discharge pipe.
- 3) Wire sensor float cable directly into

### PC : Pipe Clamp

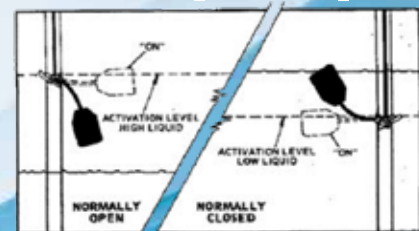

- 1) Determine activation level
- 2) Suspend the internal weight sensor control switch 7" below the determined activation level. See illustration
- 3) Wire sensor float cable directly into control panel

### SWI : Internal Weight

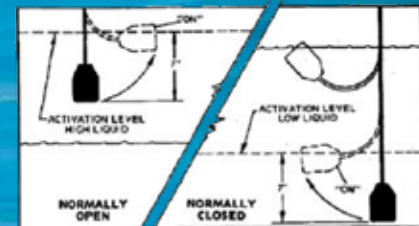

- 1) Determine activation level
- 2) Suspend the external weight sensor control switch 4" below the determined activation level. See illustration.
- 3) Wire sensor float cable directly into control panel

### SWE : External Weight

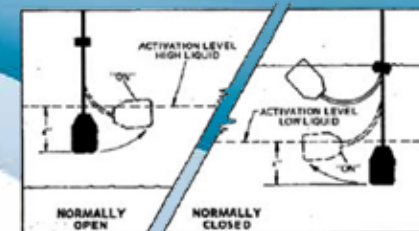

## Polythylene Basin

Models/ Modèles	Capacity Capacité USGPM	Dimensions		
		A	B	C
1822PB	18	18	22	20.5
1830PB	18	18	21	20.5
2430PB	24	24	30	28
2436PB	24	24	36	28
3036PB	30	30	36	34
3036PB	36	36	36	40

FLO FAB polythylene basins are designed to receive submersible sumps, effluent and sewage pumps up to 2 Hp for simplex and up to 1 Hp for duplex systems. Each tank is manufactured using roto-molding process. Each tank features extra heavy corners, will not crack, chip, rot, rust or corrode. Due to the light weight, no special handling equipment is required.

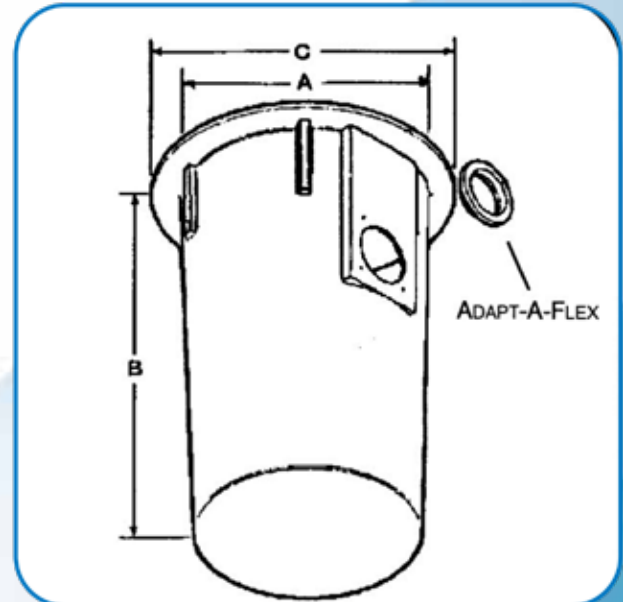

### Typical Installation

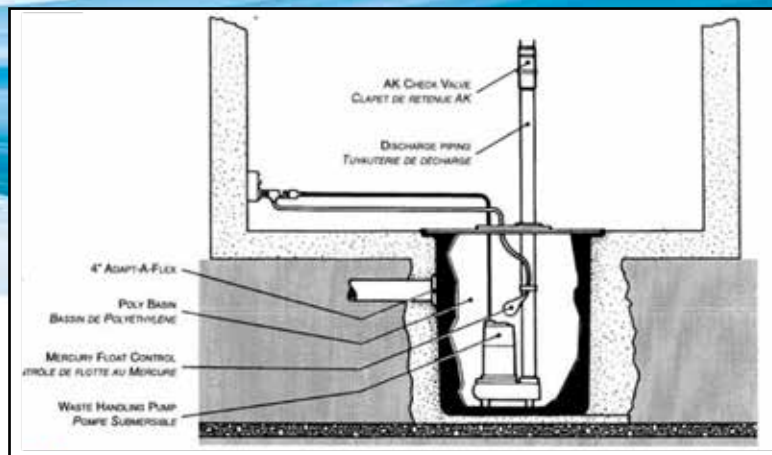

## Fiberglass Basin

Fiberglass basins are available in 18" to 72" diameters, in 6" increments. Depth are available in 30" to 120", also in 6" increments.

Construction is custom molded fiberglass reinforced polyester resin. The inside surface is gel coated from 1/2" to 1" thick to provide a smooth sealed surface. The wall thickness will withstand a water saturated sand load of 120 lbs per cubic foot with a safety factor of 2 at all depths. Inlet hubs, discharge hubs, discharge couplings are optional for field installation. If factory installation is required, identify location in both planes.

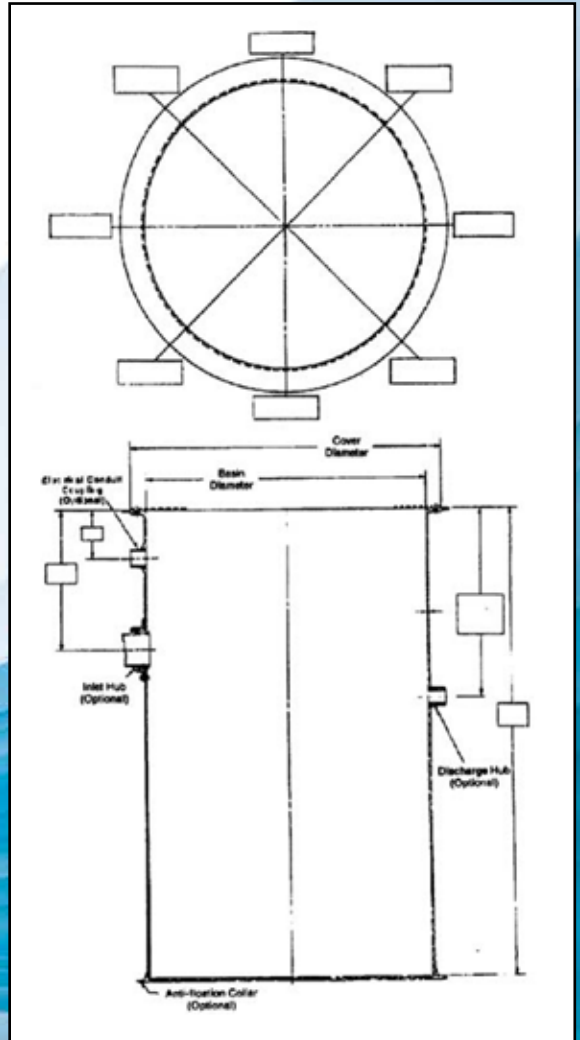

## Fiberglass Basin Parts

### Discharge and Conduit Couplings

Couplings are fastened to the wall of the basin and are used to discharge the piping and to run conduit pipe to the control panel.

Models Modèles	Dia in (po)	Material Matériaux
400-A730028	1 1/4 NPT	PVC (CPV)
400-A730029	1 1/2 NPT	PVC (CPV)
400-A730030	2 NPT	PVC (CPV)
400-A730031	2 NPT	Stainless Steel/Acier Inox.



### Inlet Hubs

Inlets include gasket and 4 fasteners for mounting on the wall of the basin.

Models Modèles	Dia in (po)	Material Matériaux
400-A730025	4	Cast Iron (Fonte)
400-A730026	6	Cast Iron (Fonte)
400-A730037	8	Cast Iron (Fonte)



### Adapt-A-Flex Fitting

Adapt-A-Flex fittings are available for 2", 3", 4", 5" and 6" plastic pipes. They are easy to install. No tooling or sealants required. Corrosion resistant.

Models Modèles	Dimension in (po)	Hole (in) Trou (po)
400-A730067	2	3
400-A730068	3	4
400-A730069	4	5
400-A730070	6	7





## Iron Hubs

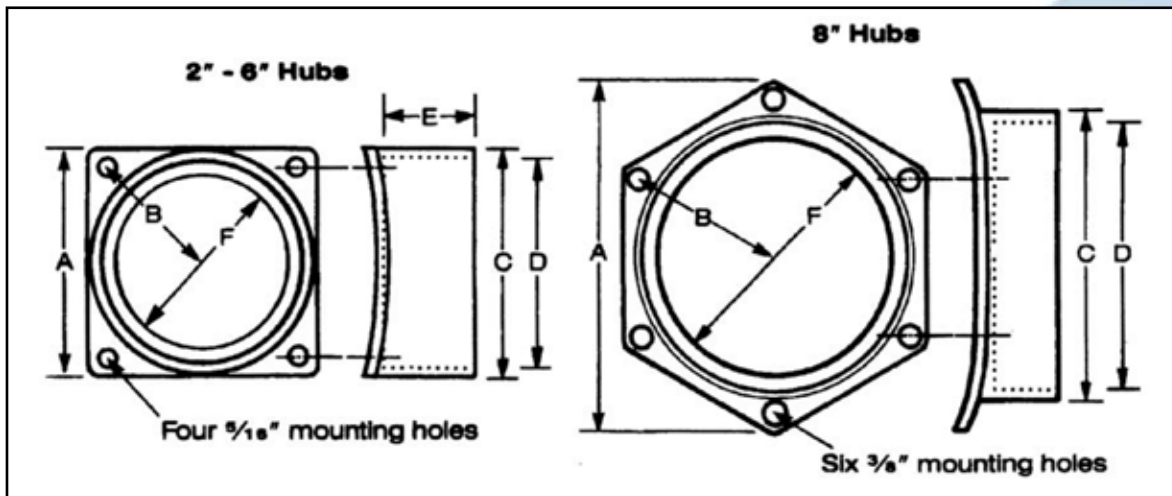

### Installation

Installation may be done at the factory or at the construction site.

- 1) Find location where the center of the hub will be positioned on the basin.
- 2) Drill or cut the hole in the basin to accept the outside diameter of the hub being installed.
- 3) Place the hub on the basin wall and drill mounting holes in the basin wall to match the hub plate.
- 4) Apply gasket to the back of the plate, mount the plate on the basin.
- 5) Insert bolts, washers and nuts, then tighten in place.

Sizes Grandeurs	2"	3"	4"	5"	6"	8"
A	4	4 <sup>3</sup> / <sub>4</sub>	6	6 <sup>3</sup> / <sub>4</sub>	8	12 <sup>1</sup> / <sub>4</sub>
B	2 <sup>1</sup> / <sub>8</sub>	2 <sup>5</sup> / <sub>8</sub>	3 <sup>3</sup> / <sub>8</sub>	3 <sup>7</sup> / <sub>8</sub>	4 <sup>5</sup> / <sub>8</sub>	5 <sup>5</sup> / <sub>8</sub>
C	3 <sup>3</sup> / <sub>4</sub>	4 <sup>5</sup> / <sub>8</sub>	5 <sup>7</sup> / <sub>8</sub>	6 <sup>5</sup> / <sub>8</sub>	7 <sup>3</sup> / <sub>4</sub>	10
D	3	4	5 <sup>1</sup> / <sub>8</sub>	5 <sup>7</sup> / <sub>8</sub>	7 <sup>1</sup> / <sub>8</sub>	9 <sup>1</sup> / <sub>4</sub>
E	2	2 <sup>1</sup> / <sub>8</sub>	2 <sup>1</sup> / <sub>4</sub>	2 <sup>1</sup> / <sub>4</sub>	2 <sup>1</sup> / <sub>4</sub>	2 <sup>1</sup> / <sub>4</sub>
F	2	3	4 <sup>1</sup> / <sub>8</sub>	5 <sup>1</sup> / <sub>4</sub>	6 <sup>1</sup> / <sub>8</sub>	8 <sup>1</sup> / <sub>8</sub>

## Basin Covers for Subs

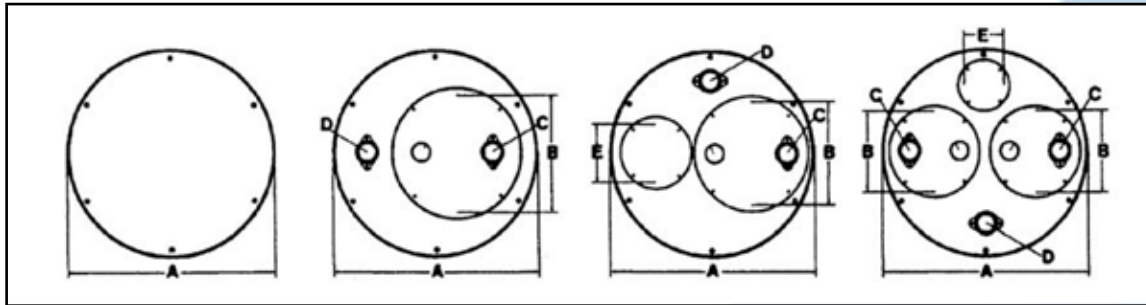

Models Modèles	Type	Basin Bassin in (po)	A Cover Couvercle in (po)	B Access Accès in (po)	C Disc. Refoul. in (po)	D Vent Event in (po)	E Inspect. in (po)	Thickness Épaisseur in (po)	Weight Poids lbs
S-2000	Solid	18	20.5	N/D	N/D	N/D	N/D	7 ga.	17
S-2400	Solid	24	28	N/D	N/D	N/D	N/D	1/4	48
S-2404	Simplex	24	28	16.	SPEC.	SPEC.	N/D	1/4	48
S-2406	Simplex	24	28	14	SPEC.	SPEC.	8	1/4	48
S-2410	Solid	24	28	N/D	SPEC.	SPEC.	N/D	10 ga.	24
S-3000	Solid	30	34	N/D	N/D	N/D	N/D	1/4	63
S-3004	Simplex	30	34	16	SPEC.	SPEC.	8	1/4	64
S-3008	Duplex	30	34	14	SPEC.	SPEC.	8	1/4	66
S-3600	Solid	36	40	N/D	N/D	N/D	N/D	1/4	90
S-3604	Simplex	36	40	16	SPEC.	SPEC.	8	1/4	93
S-3608	Duplex	36	40	16	SPEC.	SPEC.	8	1/4	95
S-4200	Solid	42	46	N/D	N/D	N/D	N/D	1/4	118
S-4202	Simplex	42	46	20	SPEC.	SPEC.	8	1/4	124
S-4204	Duplex	42	46	20	SPEC.	SPEC.	8	1/4	126
S-4800	Solid	48	54	N/D	N/D	N/D	N/D	1/4	163
S-4802	Simplex	48	54	20	SPEC.	SPEC.	8	1/4	167
S-4804	Duplex	48	54	20	SPEC.	SPEC.	10	1/4	167
S-6000	Simplex	60	66	26	SPEC.	SPEC.	10	3/8	356
S-6001	Simplex	60	66	20	SPEC.	SPEC.	10	3/8	354
S-6003	Duplex	60	66	26	SPEC.	SPEC.	10	3/8	352
S-6004	Duplex	60	66	20	SPEC.	SPEC.	10	3/8	350
S-7204	Duplex	72	78	26	SPEC.	SPEC.	10	3/8	450

Contact factory for larger diameter covers.

Other Options Available:

Rubber Seal plugs

Vent ans Discharge Conversion Kits

Cords Grips for Attaching Float Control

4" Vent

Discharge Flanges

## Round Curb Rings

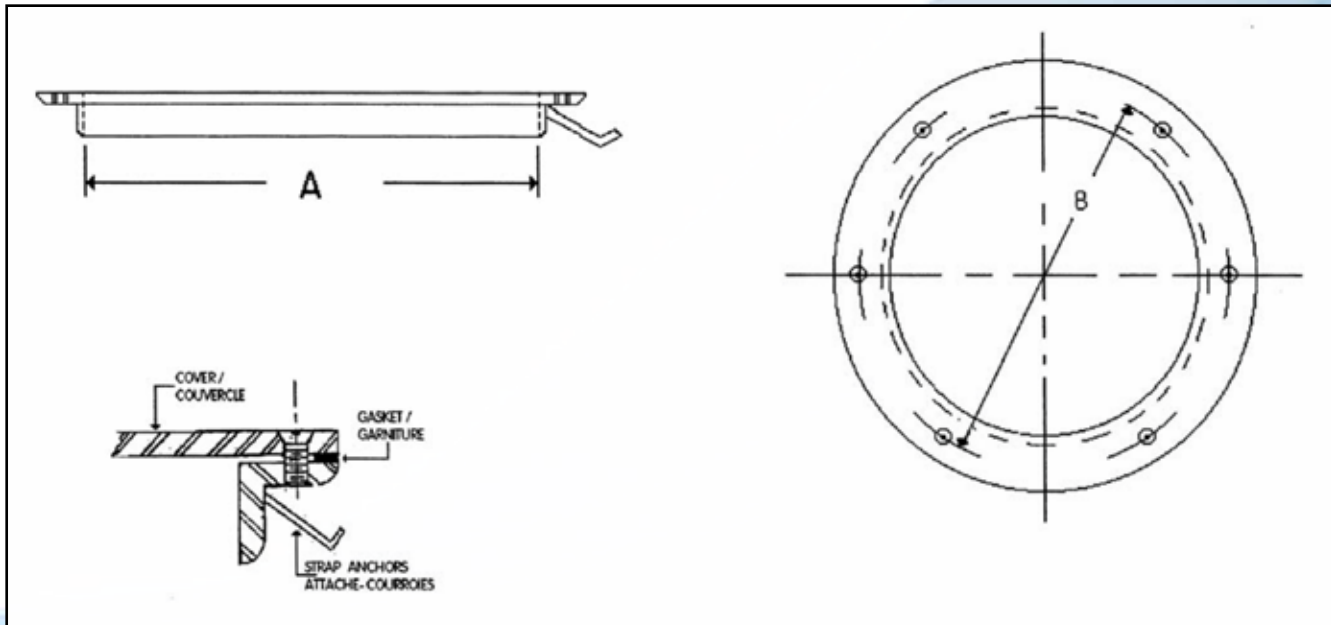

Models/ Modèles	Angle Frame Cadre à angle	Dimensions		Qty Bolts Qté de Boulons
		A	B	
87352	2 x 2 x 1/4	24	26.5	6 -3/8-16NC
87353	2 x 2 x 1/4	30	32.5	6 -3/8-16NC
87354	2 x 2 x 1/4	36	38.5	6 -3/8-16NC
87355	2 x 2 x 1/4	42	44.5	6 -3/8-16NC
87356	3 x 3 x 1/4	48	51	6 -3/8-16NC
87357	3 x 3 x 1/4	60	63	6 -3/8-16NC
88297	3 x 3 x 1/4	72	75	6 -3/8-16NC

All dimensions are in inches

**Finish:** Coat of red oxide paint

## Square Steel Curbed Frame Covers

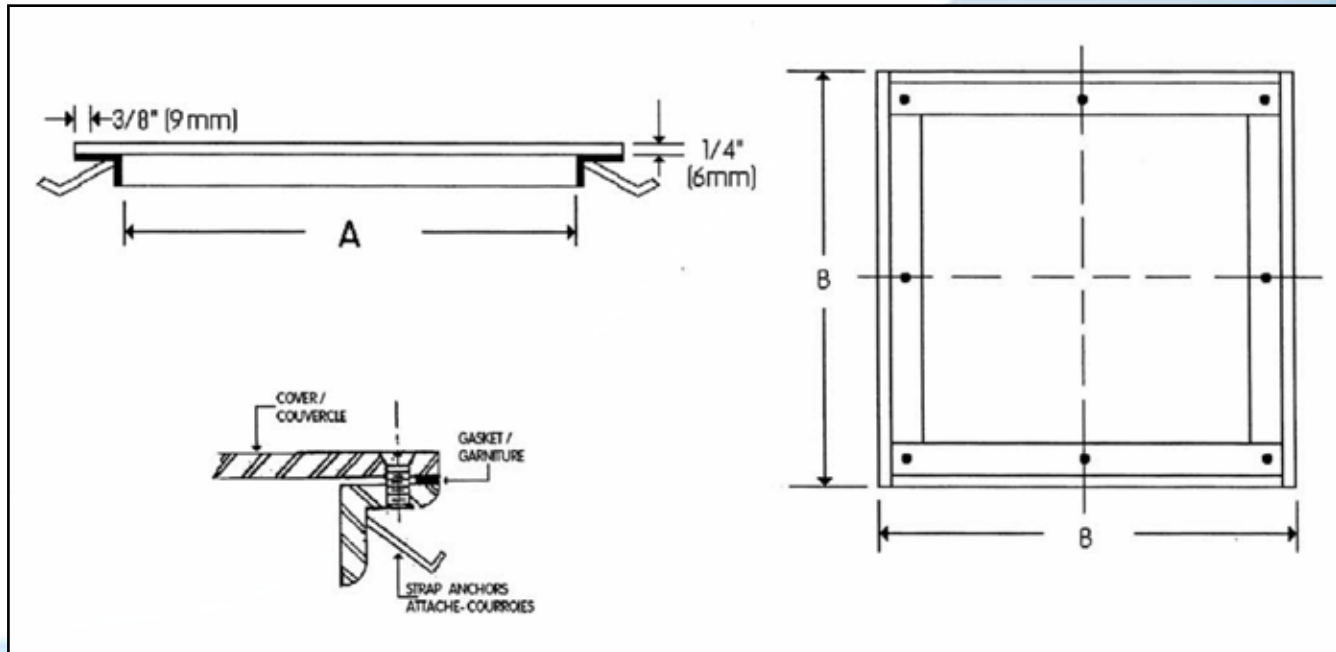

Models/ Modèles	Angle Frame Cadre à angle	Dimensions		Qty Bolts Qté de Boulons
		A	B	
87352	2 x 2 x 1/4	24	28	9 -3/8-16NC
87353	2 x 2 x 1/4	30	34	9 -3/8-16NC
87354	2 x 2 x 1/4	36	40	9 -3/8-16NC
87355	2 x 2 x 1/4	42	46	9 -3/8-16NC
87356	3 x 3 x 1/4	48	54	9 -3/8-16NC
87357	3 x 3 x 1/4	60	66	9 -3/8-16NC
88297	3 x 3 x 1/4	72	78	9 -3/8-16NC

All dimensions are in inches

**Finish:** Coat of red oxide paint

## Square Steel Curbed Frame Covers

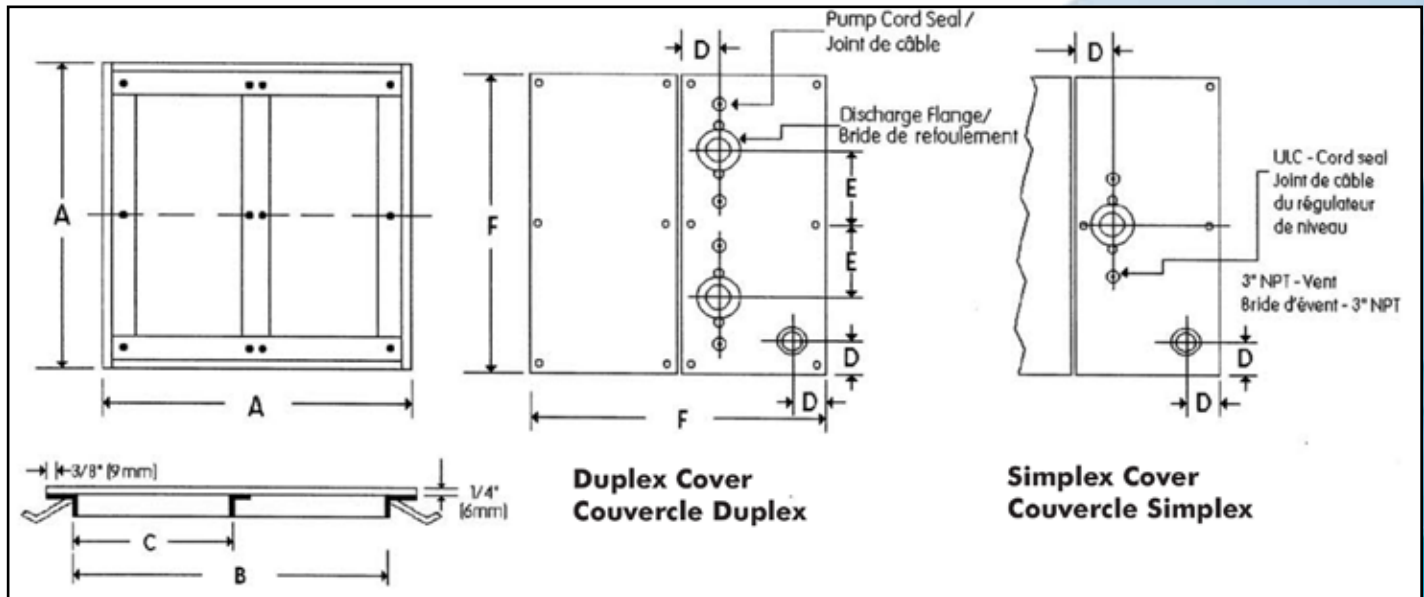

	Models/ Modèles	Angle Frame Cadre à angle	Dimensions					
			A	B	C	D	E	F
Simplex	2424-CR-2PS	2 x 2 x 1/4	28	24	12	6	N/D	27
	3030-CR-2PS	2 x 2 x 1/4	34	30	15	6	N/D	33
	3636-CR-2PS	2 x 2 x 1/4	40	36	18	6	N/D	39
Duplex	4848-CR-2PS	2.5x2.5x 1/4	53	48	24	7	N/D	52
	2424-CR-2PD	2 x 2 x 1/4	28	24	12	6	6	27
	3030-CR-2PD	2 x 2 x 1/4	34	30	15	6	8	33
	3636-CR-2PD	2 x 2 x 1/4	40	36	18	6	9	39
	4242-CR-2PD	2 x 2 x 1/4	46	42	21	6	10	45
	4848-CR-2PD	2.5x2.5x 1/4	53	48	24	7	13	52
	6060-CR-2PD	2.5x2.5x 1/4	65	60	30	7	16	64
	7272-CR-2PD	2.5x2.5x 1/4	77	72	36	8	16	76

All dimensions are in inches

**Finish:** Coat of red oxide paint  
 Checkered Plates & Galvanized  
 Available on request.  
 Specify discharge.

### Standard Equipment

3" NPT Vent coupling, discharge flange with o'ring, pump(s), liquid level control seal and cover gasket. Size when ordering.



# Curb Frame & Cover Plate

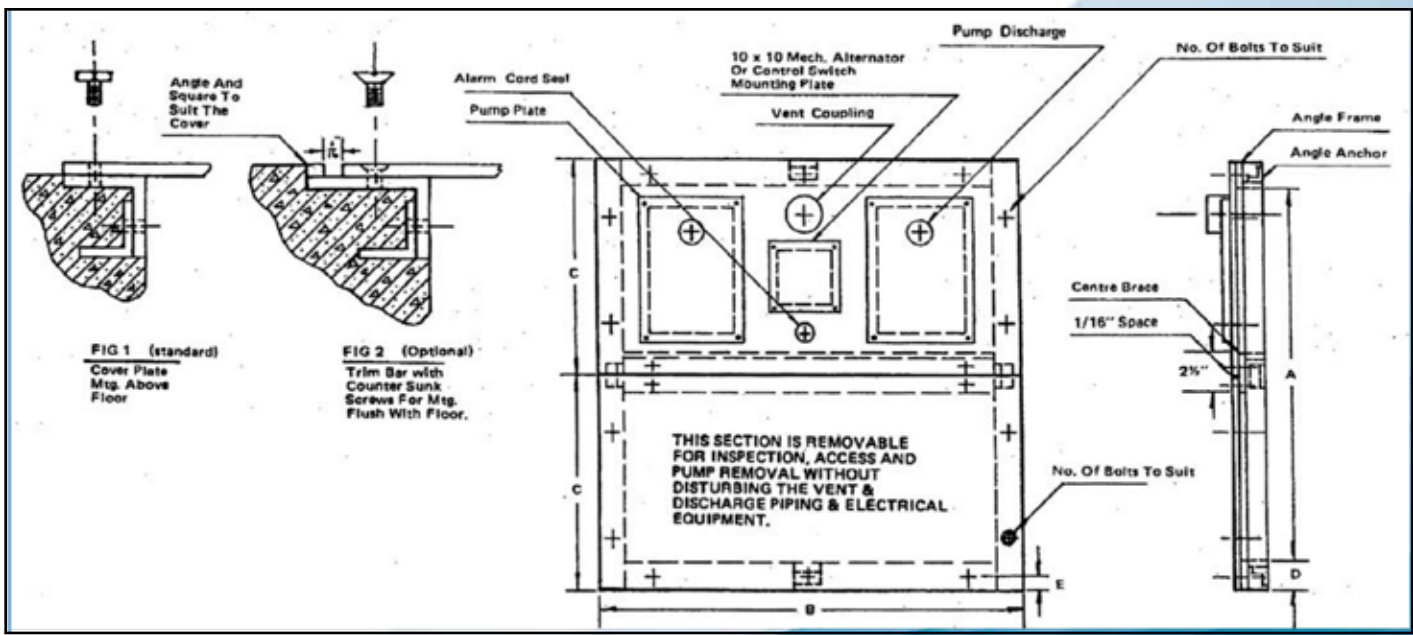

Angle Frame Cadre à angle	Dimensions					
	A	B	C	D	E	F
2 x 2 x 1/4	42	46	23	2	1	16
3 x 3 x 1/4	48	54	27	3	1 1/2	16
3 x 3 x 1/4	54	60	30	3	1 1/2	20
3 x 3 x 5/16	60	66	33	3	1 1/2	20
3 x 3 x 5/16	66	72	36	3	1 1/2	20
3 x 3 x 3/8	72	78	39	3	1 1/2	20

All dimensions are in inches and may vary ± 1/8"

## Cover

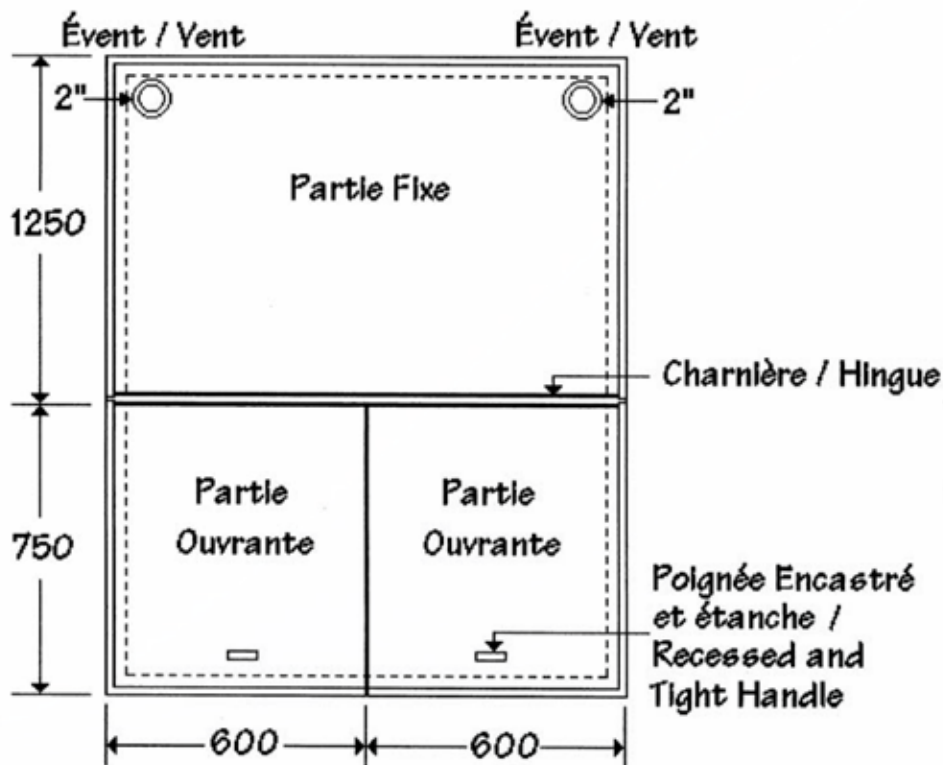

Parties Ouvrantes Montées sur Charnière  
Hinged Opening Sections

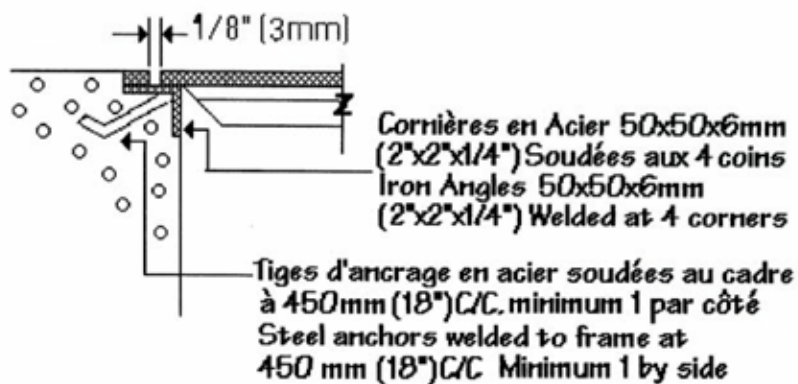

## Holding Tank Type "A"

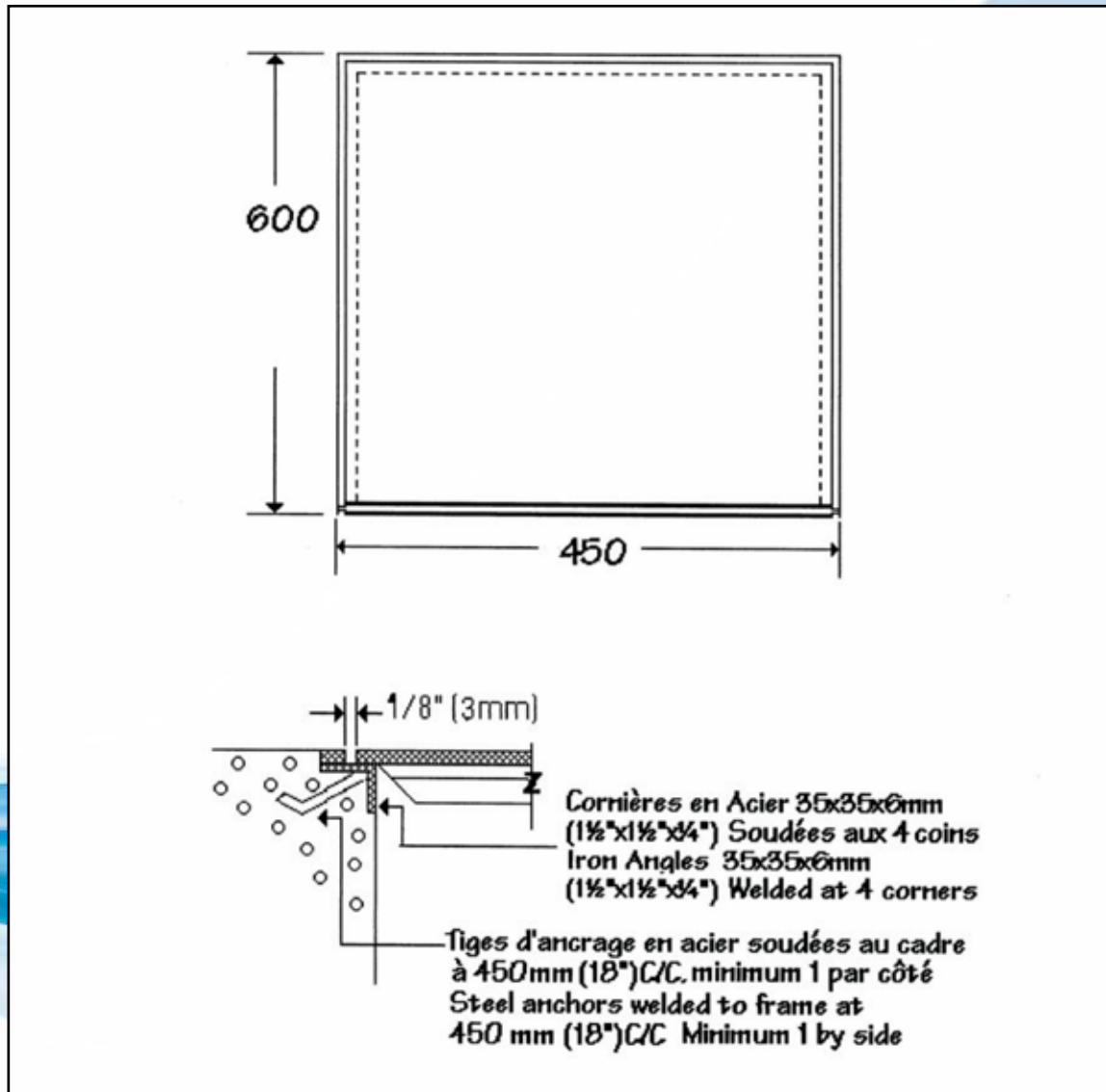

**Type "A":** With non-slippery, grooved plate, 1/4" thick iron, reinforced bottom with 1 1/2" x 1 1/2" x 1/4" iron corners, cross shape welding at 18" C/C, with 3/4" to 2" C/C drainage holes.



## Float Bracket

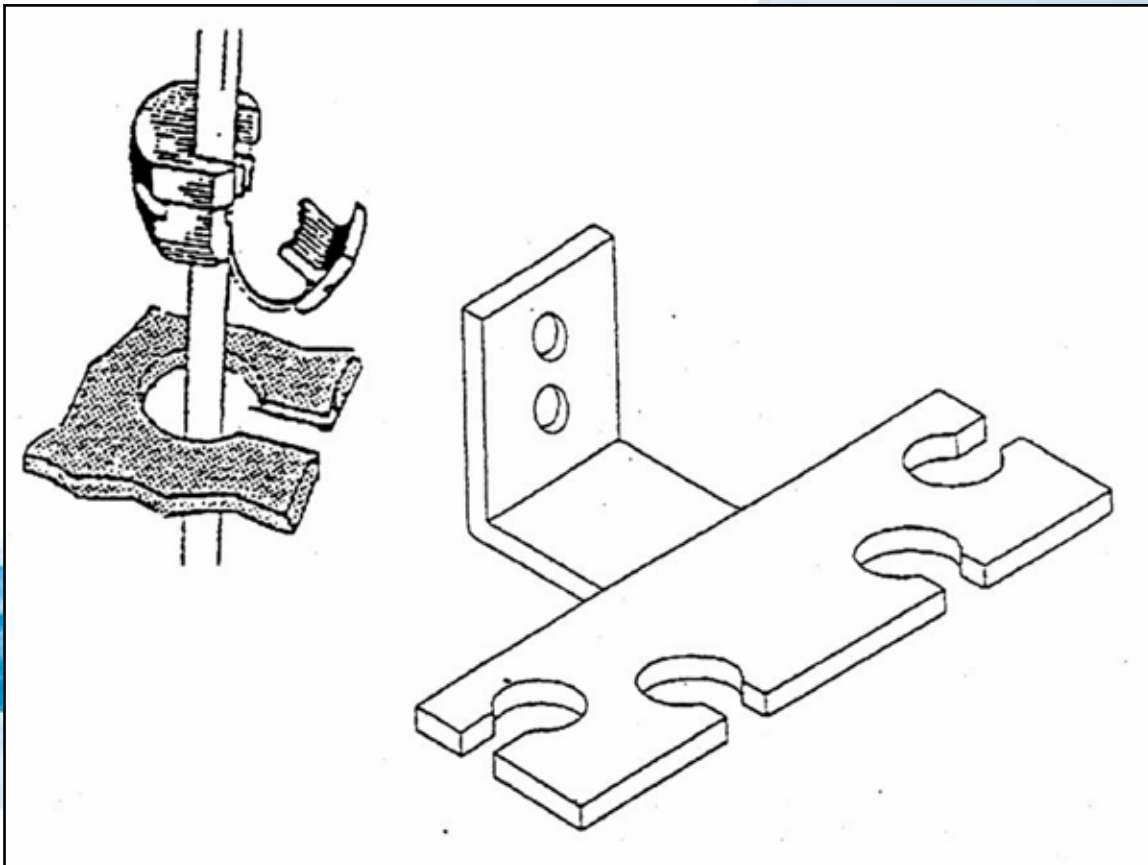

Stainless Steel

Steel

## Duplex Junction Box

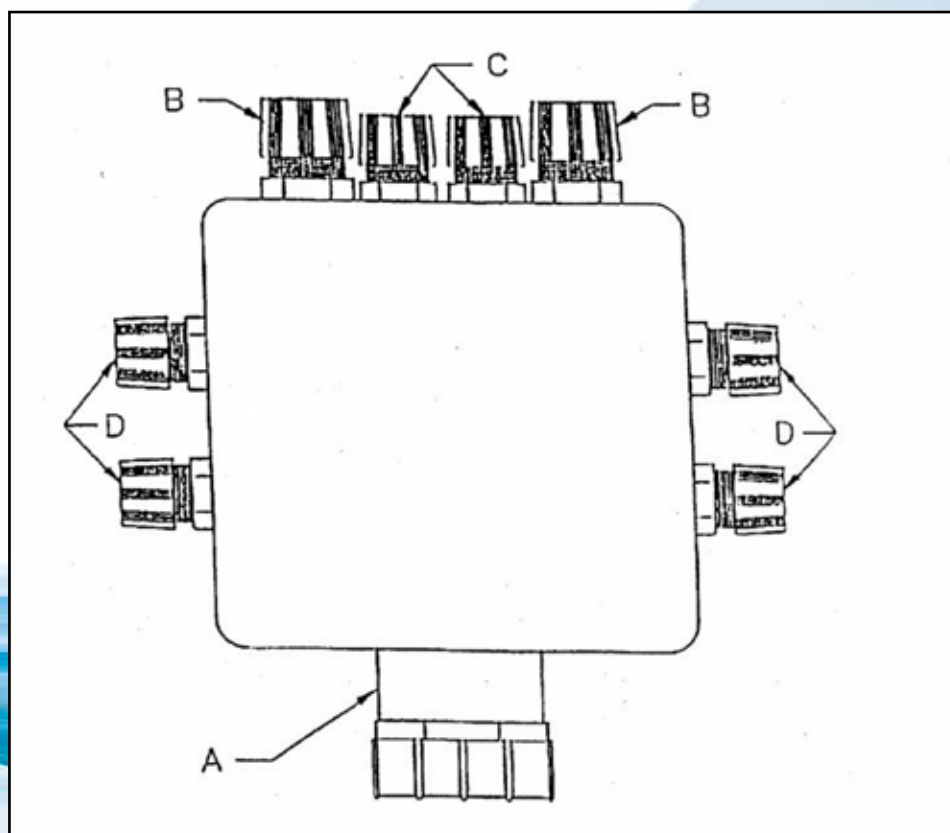

### **6 x 6 x 4 PVC plastic duplex junction box with motor control cables**

- A) 2» Inlet Hub
- B) Motor Power Cord Grip (Size per motor required)
- C) Motor Control Cord Grip (Size per motor required)
- D) 5/16» to 3/8» diameter Level Switch Cord Grip



**● Accessories**

**Control Panel**

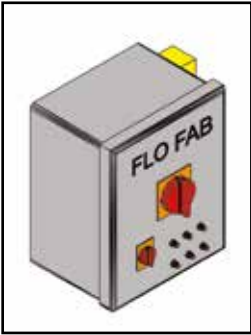

FLO FAB Standard UL or CSA NEMA 1 — enclosure. Includes main disconnect switch, internal circuit, breakers, transformer, low suction pressure switch and pilot light, hand-off auto switch, pump running light, current-relay, minimum run timer, automatic transfer to lag pump circuit, lead pump selector switch, power on light, dry contact for remote signal.

Model

- Simplex    SSP    115/1    208/3
- Duplex    DSP    230/1    460/3
- Triplex    TSP    575/3

**Tank Alert Float**

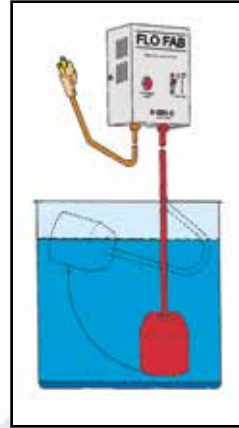

- Nema 1 Compliance in a metal alarm panel
- When used with a pump application, the Tank Alert may be connected to a circuit breaker other than the pump circuit. This allows the Tank Alert to operate even if the pump circuit should fail.

Model

- 101 HW
  - 101 LW
  - With Dry Contact
  - Without Dry Contact
- 120/1/60**

**Mechanical Float Switch**

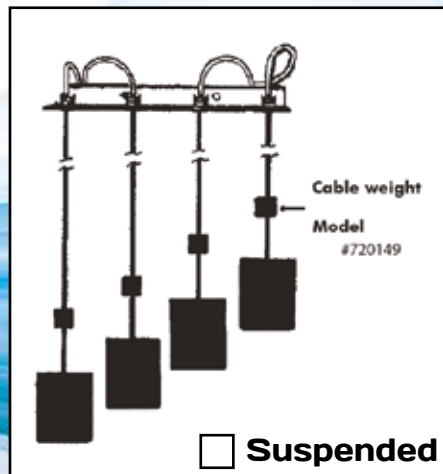
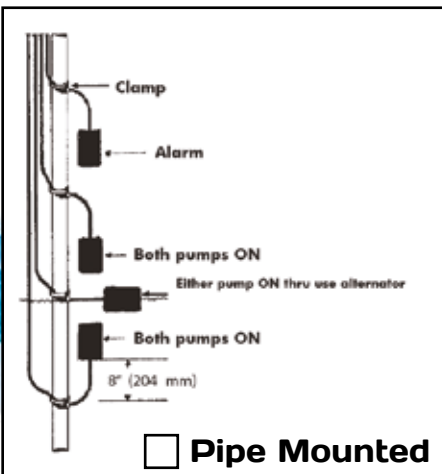

#720145 Bracket

- Not Included
- Included

Model

Contacts

- 30 720165    with Plug
- without Plug

QTY. \_\_\_\_\_

**General arrangement for Single Pump float operation (plug in type)**

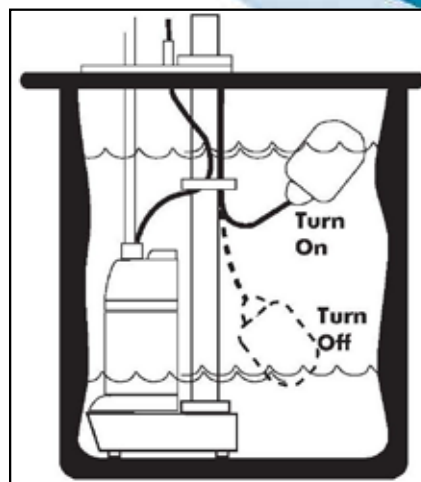
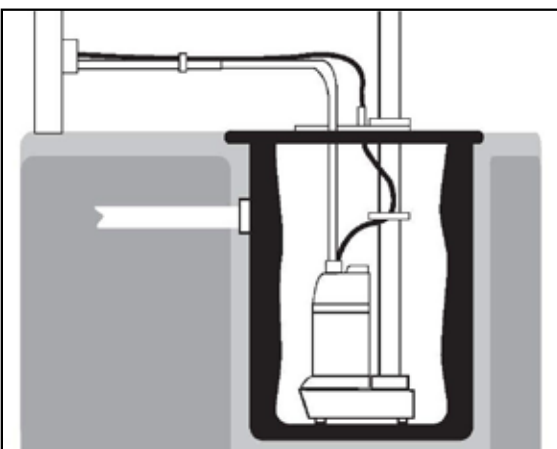

Float Model

Contacts

- 30" 720165   N/O

QTY. \_\_\_\_\_



**Polyethylene Basin**

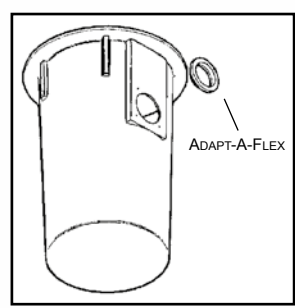

- Polyethylene
  - Fiberglass
- Model
- 1830 - 30 gal.
  - 2436 - 70 gal.
  - 3636 - 159 gal.
  - 4848 - 376 gal.

**Steel Basin Covers**

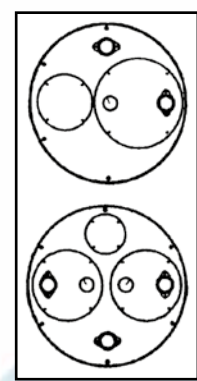

- Simplex
  - Duplex
- Model
- 18"
  - 24"
  - 36"
  - 48"

**Check Valve**

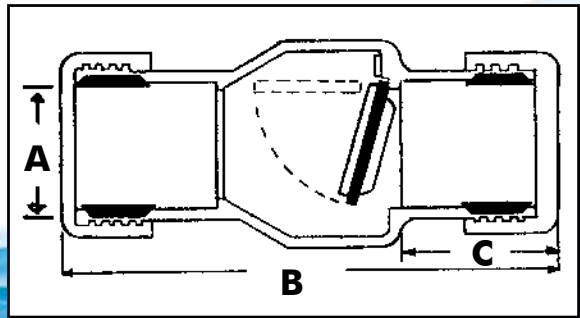

**Type CVP**

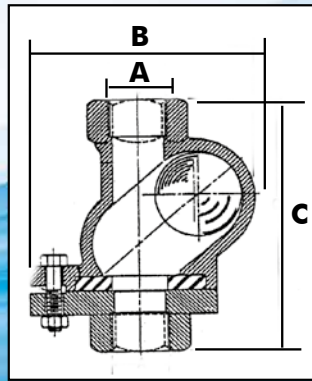

**Type CBO125-CBO200**

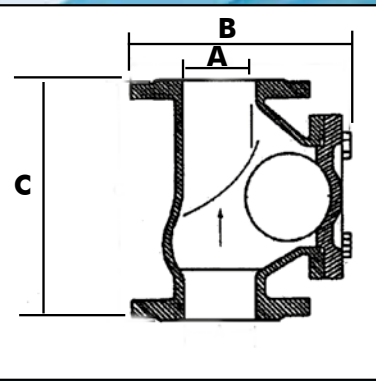

**Type CBO300-CBO400**

√	Models	A	B		C		Pressure Test lb/po/ca
			mm	in	mm	in	
	<b>CVP0125</b>	1 1/4" NPT	132	5 1/4	28	1 1/8	
	<b>CVP0150</b>	1 1/2" NPT	132	5 1/4	28	1 1/8	
	<b>CVP0200</b>	2" NPT	245	9 3/4	70	2 3/4	
	<b>CVP0300</b>	3" NPT	350	14	100	4	
	<b>CB0125</b>	1 1/4" NPT	119	4 11/16	135	5 5/16	150
	<b>CB0150</b>	1 1/2" NPT	119	4 11/16	135	5 5/16	150
	<b>CB0200</b>	2" NPT	157	6 3/16	175	6 7/8	150
	<b>CB0300</b>	3" Flanged	214	8 7/16	246	9 1/16	150
	<b>CB0400</b>	4" Flanged	282	11 1/8	300	11 3/16	150
	<b>CB0600</b>	6"	398	15 11/16	421	16 9/16	150
	<b>CB0800</b>	8"	495	19 1/2	533	21	150



## 18" Fiberglass Basins



√	Models	DIA X DEPTH	CAPACITY	WEIGHT
	<b>1822FB-LC</b>	18 X 22	24	12
	<b>1830FB-LC</b>	18 X 30	33	15
	<b>1836FB-LC</b>	18 X 36	40	18
	<b>1842FB-LC</b>	18 X 42	46	21
	<b>1848FB-LC</b>	18 X 48	53	24
	<b>1854FB-LC</b>	18 X 54	59	27
	<b>1860FB-LC</b>	18 X 60	66	30
	<b>1866FB-LC</b>	18 X 66	73	33
	<b>1872FB-LC</b>	18 X 72	79	36
	<b>1878FB-LC</b>	18 X 78	86	39
	<b>1884FB-LC</b>	18 X 84	93	42
	<b>1890FB-LC</b>	18 X 90	99	45
	<b>1896FB-LC</b>	18 X 96	106	48

Suitable for liquids up to 140°F  
 Cover not included in basin price See below  
 Adapt-a-flex and cast iron hubs sold separately

**Longer Depths Available**  
**Basins 48" and Deeper c/w Anti-Float**  
**If Anti-Float not required please call for P & D**

## Covers for 18" Dia. Basins

BLANK  
Steel / S. foam



BLANK / steel  
Checker Plated



SIMPLEX  
Steel / SF (1pc)



SIMPLEX 2 PC  
Structural foam



√	Models	MATERIAL	WEIGHT
	<b>18B</b>	BLANK STEEL 3/16" THICK	14
	<b>18BCP</b>	BLANK STEEL checker plated	14
	<b>18BSF</b>	BLANK STRUCTURAL FOAM	5

√	Models	MATERIAL	WEIGHT
	<b>18SSF*</b>	SIMPLEX SF (1pc)	7
	<b>SF114-2PC*</b>	SIMPLEX SPLIT 2 PC FOAM	10
	<b>18S*</b>	SIMPLEX STEEL 3/16" THICK	10

\*c/w 2" discharge & 3" vent flanges

## 24" Fiberglass Basins



✓	Models	DIA X DEPTH	CAPACITY	WEIGHT
	<b>2424FB-LC</b>	24 X 24	47	30
	<b>2430FB-LC</b>	24 X 30	59	35
	<b>2436FB-LC</b>	24 X 36	70	40
	<b>2442FB-LC</b>	24 X 42	82	45
	<b>2448FB-LC</b>	24 X 48	94	50
	<b>2454FB-LC</b>	24 X 54	106	54
	<b>2460FB-LC</b>	24 X 60	117	59
	<b>2466FB-LC</b>	24 X 66	129	64
	<b>2472FB-LC</b>	24 X 72	141	69
	<b>2478FB-LC</b>	24 X 78	153	92
	<b>2484FB-LC</b>	24 X 84	164	96
	<b>2490FB-LC</b>	24 X 90	176	100
	<b>2496FB-LC</b>	24 X 96	188	105

Suitable for liquids up to 140°F  
 Cover not included in basin price See below  
 Adapt-a-flex and cast iron hubs sold separately

**Longer Depths Available**  
**Basins 48" and Deeper c/w Anti-Float**  
**If Anti-Float not required please call for P & D**

## Covers for 24" Dia. Basins

Steel / F/ S Foam



SLIMPLEX SF

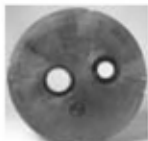

SIMPLEX / steel

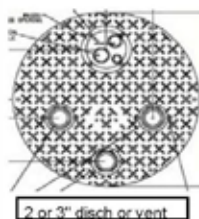
BLANK / steel  
Checker PlatedDUPLEX  
Structural foam

✓	Models	MATERIAL	WEIGHT
	<b>24B</b>	BLANK STEEL 3/16" THICK	48
	<b>24BCP</b>	BLANK STEEL checker plated	48
	<b>24BF</b>	BLANK FIBERGLASS	18
	<b>SF24B-BL</b>	BLANK STRUCTURAL FOAM	20
	<b>SF24S-BL*</b>	SIMPLEX STRUCTURAL FOAM	22
	<b>LB-10-S2401-1</b>	SIMPLEX STEEL 10 gauge	
	<b>24SI</b>	SIMPLEX STEEL 3/16" THICK	50
	<b>SF24D-BL*</b>	DUPLEX STRUCTURAL FOAM	24
	<b>JC24H</b>	3/16" STEEL HINGED DOOR COVER	

\*c/w 2" discharge & 3" vent flanges



### 30" Fiberglass Basins



✓	Models	DIA X DEPTH	CAPACITY	WEIGHT
	<b>3030FB-LC</b>	30 X 30	92	46
	<b>3036FB-LC</b>	30 X 36	110	52
	<b>3042FB-LC</b>	30 X 42	129	58
	<b>3048FB-LC</b>	30 X 48	147	64
	<b>3054FB-LC</b>	30 X 54	165	70
	<b>3060FB-LC</b>	30 X 60	184	76
	<b>3066FB-LC</b>	30 X 66	202	112
	<b>3072FB-LC</b>	30 X 72	220	118
	<b>3078FB-LC</b>	30 X 78	239	125
	<b>3084FB-LC</b>	30 X 84	257	133
	<b>3090FB-LC</b>	30 X 90	275	141
	<b>3096FB-LC</b>	30 X 96	294	148

Suitable for liquids up to 140°F  
 Cover not included in basin price See below  
 Adapt-a-flex and cast iron hubs sold separately

**Longer Depths Available**  
**Basins 48" and Deeper c/w Anti-Float**  
**If Anti-Float not required please call for P & D**

### Covers for 30" Dia. Basins

BLANK  
Steel / Fiberglass



BLANK / steel  
Checker Plated



SIMPLEX W/ INSP  
Steel only



DUPLEX W/ INSP  
Steel / Fiberglass



✓	Models	MATERIAL	WEIGHT
	<b>30B</b>	BLANK STEEL 3/16" THICK	65
	<b>30BCP</b>	BLANK STEEL checker plated	65
	<b>30BF</b>	BLANK FIBERGLASS	20
	<b>LB-10S3001</b>	SIMPLEX STEEL 10 gauge	
	<b>30SI*</b>	SIMPLEX STEEL 3/16" THICK	69
	<b>30DIF*</b>	DUPLEX FIBERGLASS	30
	<b>LB-10S3002</b>	DUPLEX STEEL 10 gauge	
	<b>30DI*</b>	DUPLEX STEEL 3/16" THICK	75
	<b>JC30H</b>	3/16" STEEL HINGED DOOR COVER	

\*c/w 2" discharge & 3" vent flanges



## 36" Fiberglass Basins



√	Models	DIA X DEPTH	CAPACITY	WEIGHT
	<b>3636FB-LC</b>	36 X 36	159	65
	<b>3642FB-LC</b>	36 X 42	185	71
	<b>3648FB-LC</b>	36 X 48	211	78
	<b>3654FB-LC</b>	36 X 54	238	86
	<b>3660FB-LC</b>	36 X 60	264	93
	<b>3666FB-LC</b>	36 X 66	291	159
	<b>3672FB-LC</b>	36 X 72	317	168
	<b>3678FB-LC</b>	36 X 78	344	177
	<b>3684FB-LC</b>	36 X 84	370	186
	<b>3690FB-LC</b>	36 X 90	397	196
	<b>3696FB-LC</b>	36 X 96	423	205

Suitable for liquids up to 140°F  
 Cover not included in basin price See below  
 Adapt-a-flex and cast iron hubs sold separately

**Longer Depths Available**  
**Basins 48" and Deeper c/w Anti-Float**  
**If Anti-Float not required please call for P & D**

## Covers for 36" Dia. Basins

BLANK  
Steel / Fiberglass



SIMPLEX W/ INSP  
Steel only



BLANK / steel  
Checker Plated



DUPLEX W/ INSP  
Steel / Fiberglass



√	Models	MATERIAL	WEIGHT
	<b>36B</b>	BLANK STEEL 3/16" THICK	90
	<b>36BCP</b>	BLANK STEEL checker plated	90
	<b>36BF</b>	BLANK FIBERGLASS	30
	<b>LB-10S3601</b>	SIMPLEX STEEL 10 gauge	
	<b>36SI*</b>	SIMPLEX STEEL 3/16" THICK	95
	<b>LB-10S3602</b>	DUPLEX STEEL 10 gauge	
	<b>36DI*</b>	DUPLEX STEEL 3/16" THICK	110
	<b>JC36H</b>	1/4" STEEL HINGED DOOR COVER	

\*c/w 2" discharge & 3" vent flanges





## 42" Fiberglass Basins



√	Models	DIA X DEPTH	CAPACITY	WEIGHT
	<b>4230FB-LC</b>	42 X 30	180	81
	<b>4236FB-LC</b>	42 X 36	216	94
	<b>4242FB-LC</b>	42 X 42	252	105
	<b>4248FB-LC</b>	42 X 48	288	116
	<b>4254FB-LC</b>	42 X 54	324	128
	<b>4260FB-LC</b>	42 X 60	360	139
	<b>4266FB-LC</b>	42 X 66	396	183
	<b>4272FB-LC</b>	42 X 72	432	194
	<b>4278FB-LC</b>	42 X 78	468	208
	<b>4284FB-LC</b>	42 X 84	504	221
	<b>4290FB-LC</b>	42 X 90	540	235
	<b>4296FB-LC</b>	42 X 96	576	249

Suitable for liquids up to 140°F  
 Cover not included in basin price See below  
 Adapt-a-flex and cast iron hubs sold separately

**Longer Depths Available**  
**Basins 48" and Deeper c/w Anti-Float**  
**IF Anti-Float not required please call for P & D**

## Covers for 42" Dia. Basins

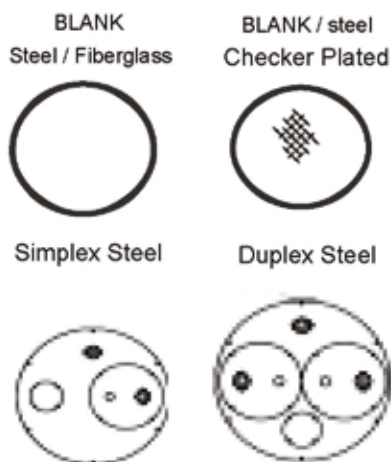

√	Models	MATERIAL	WEIGHT
	<b>42B</b>	BLANK STEEL 3/16" THICK	128
	<b>42BCP</b>	BLANK STEEL checker plated	128
	<b>42BF</b>	BLANK FIBERGLASS	40
	<b>42SI*</b>	SIMPLEX STEEL 1/4" THICK	135
	<b>42DI*</b>	DUPLEX STEEL 1/4" THICK	140
	<b>LB-S42HDC</b>	1/4" STEEL HINGED DOOR COVER	

\*c/w 2" discharge & 3" vent flanges



## 48" Fiberglass Basins



✓	Models	DIA X DEPTH	CAPACITY	WEIGHT
	<b>4830FB-LC</b>	48 X 30	235	97
	<b>4836FB-LC</b>	48 X 36	282	110
	<b>4842FB-LC</b>	48 X 42	329	123
	<b>4848FB-LC</b>	48 X 48	376	136
	<b>4854FB-LC</b>	48 X 54	423	148
	<b>4860FB-LC</b>	48 X 60	470	161
	<b>4866FB-LC</b>	48 X 66	517	244
	<b>4872FB-LC</b>	48 X 72	564	260
	<b>4878FB-LC</b>	48 X 78	611	280
	<b>4884FB-LC</b>	48 X 84	658	299
	<b>4890FB-LC</b>	48 X 90	705	318
	<b>4896FB-LC</b>	48 X 96	752	338

Suitable for liquids up to 140°F  
 Cover not included in basin price See below  
 Adapt-a-flex and cast iron hubs sold separately

**Longer Depths Available**  
**Basins 48" and Deeper c/w Anti-Float**  
**If Anti-Float not required please call for P & D**

## Covers for 48" Dia. Basins

BLANK  
Steel / Fiberglass



SIMPLEX W/ INSP  
Steel only



BLANK / steel  
Checker Plated



DUPLEX W/ INSP  
Steel / Fiberglass



✓	Models	MATERIAL	WEIGHT
	<b>48B</b>	BLANK STEEL 1/4" THICK	165
	<b>48BCP</b>	BLANK STEEL checker plated	165
	<b>48BF</b>	BLANK FIBERGLASS	65
	<b>48SI*</b>	SIMPLEX STEEL 1/4" THICK	170
	<b>48DI*</b>	DUPLEX STEEL 1/4" THICK	180
	<b>JC48H</b>	1/4" STEEL HINGED DOOR COVER	

\*c/w 2" discharge & 3" vent flanges



## 60" Fiberglass Basins



√	Models	DIA X DEPTH	CAPACITY	WEIGHT
	<b>6036FB-LC</b>	60 X 36	440	309
	<b>6042FB-LC</b>	60 X 42	514	334
	<b>6048FB-LC</b>	60 X 48	587	358
	<b>6054FB-LC</b>	60 X 54	661	382
	<b>6060FB-LC</b>	60 X 60	734	406
	<b>6066FB-LC</b>	60 X 66	808	430
	<b>6072FB-LC</b>	60 X 72	881	454
	<b>6078FB-LC</b>	60 X 78	955	483
	<b>6084FB-LC</b>	60 X 84	1028	512
	<b>6090FB-LC</b>	60 X 90	1102	540
	<b>6096FB-LC</b>	60 X 96	1175	569

Suitable for liquids up to 140°F  
 Cover not included in basin price See below  
 Adapt-a-flex and cast iron hubs sold separately

**Longer Depths Available**  
**Basins 48" and Deeper c/w Anti-Float**  
**IF Anti-Float not required please call for P & D**

## Covers for 60" Dia. Basins

BLANK  
Steel / Fiberglass



BLANK / steel  
Checker Plated



SIMPLEX W/ INSP  
Steel only



DUPLEX W/ INSP  
Steel / Fiberglass



√	Models	MATERIAL	WEIGHT
	<b>60B</b>	BLANK STEEL 1/4" THICK	365
	<b>60BCP</b>	BLANK STEEL checker plated	365
	<b>60BF</b>	BLANK FIBERGLASS	75
	<b>60SI*</b>	SIMPLEX STEEL 1/4" THICK	380
	<b>60DI*</b>	DUPLEX STEEL 1/4" THICK	395
	<b>LB-S60HDC</b>	3/8" STEEL HINGED DOOR COVER	

\*c/w 2" discharge & 3" vent flanges



**SIMPLEX METAL COVER**

**Simplex Metal Covers**

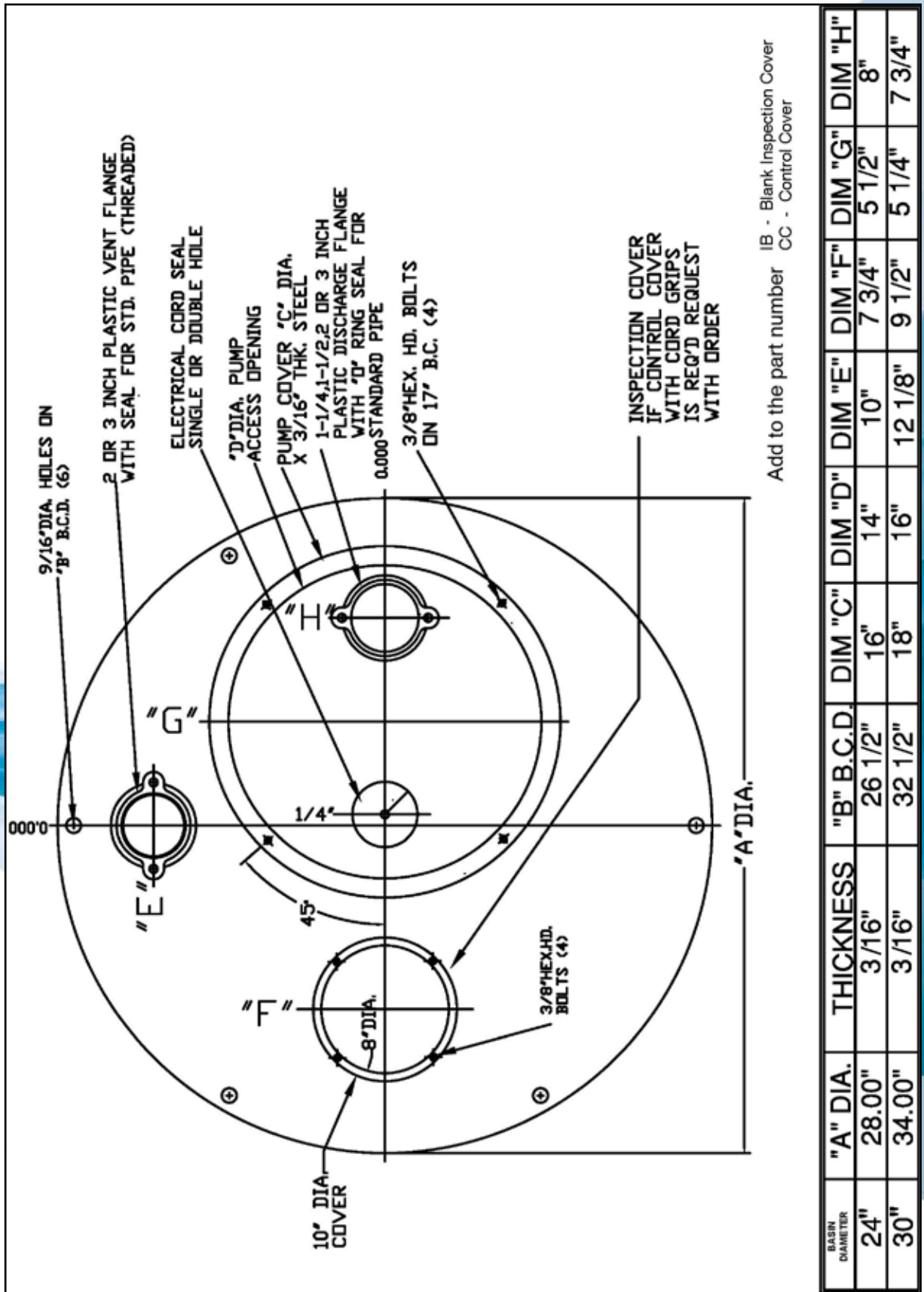

Add to the part number  
 IB - Blank Inspection Cover  
 CC - Control Cover

BASIN DIAMETER	"A" DIA.	THICKNESS	"B" B.C.D.	DIM "C"	DIM "D"	DIM "E"	DIM "F"	DIM "G"	DIM "H"
24"	28.00"	3/16"	26 1/2"	16"	14"	10"	7 3/4"	5 1/2"	8"
30"	34.00"	3/16"	32 1/2"	18"	16"	12 1/8"	9 1/2"	5 1/4"	7 3/4"



# Simplex Metal Covers

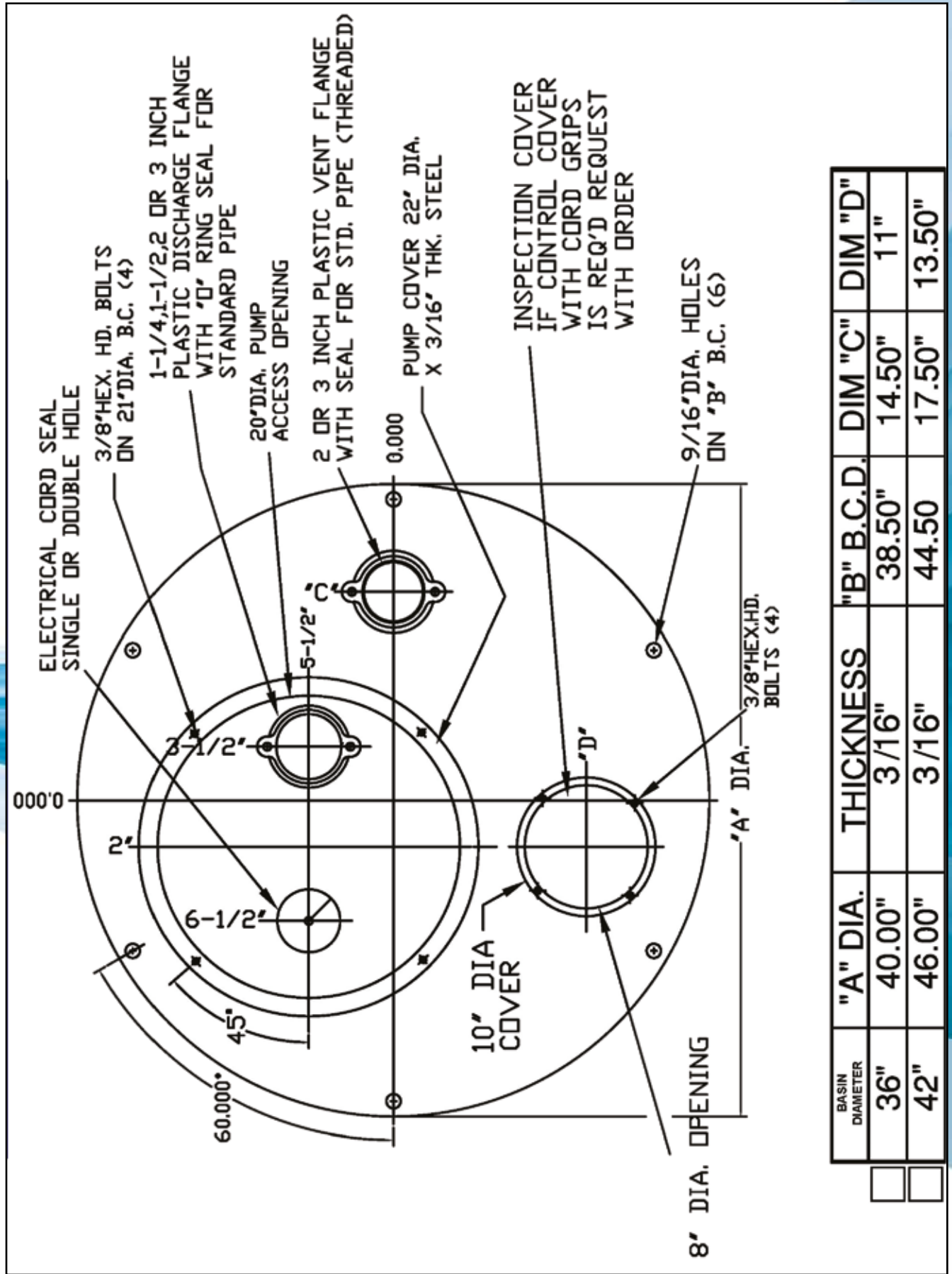

BASIN DIAMETER	"A" DIA.	THICKNESS	"B" B.C.D.	"C" DIA.	"D" DIA.
36"	40.00"	3/16"	38.50"	14.50"	11"
42"	46.00"	3/16"	44.50"	17.50"	13.50"

# Simplex Metal Covers

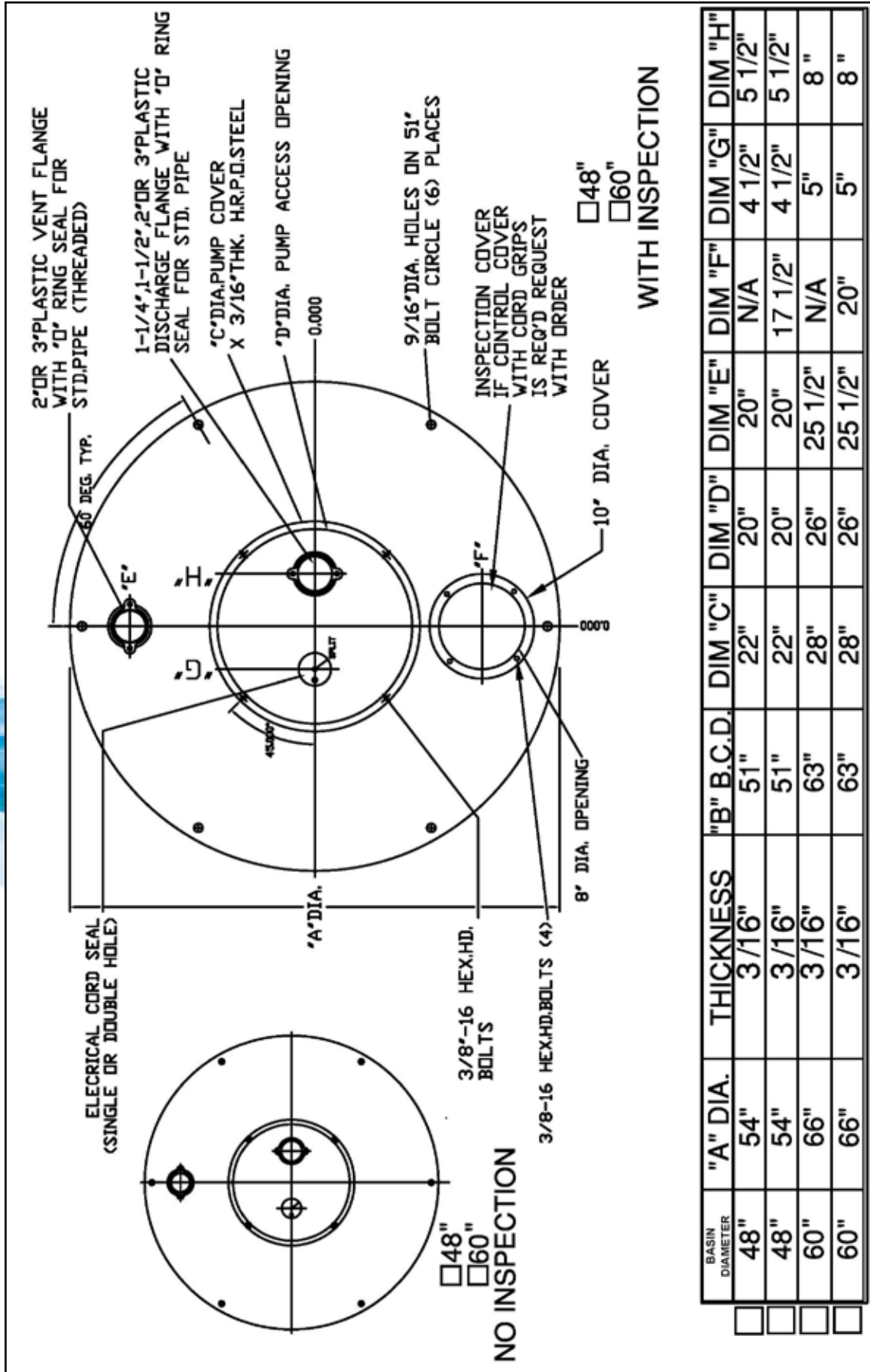



# 24" Duplex Metal Covers

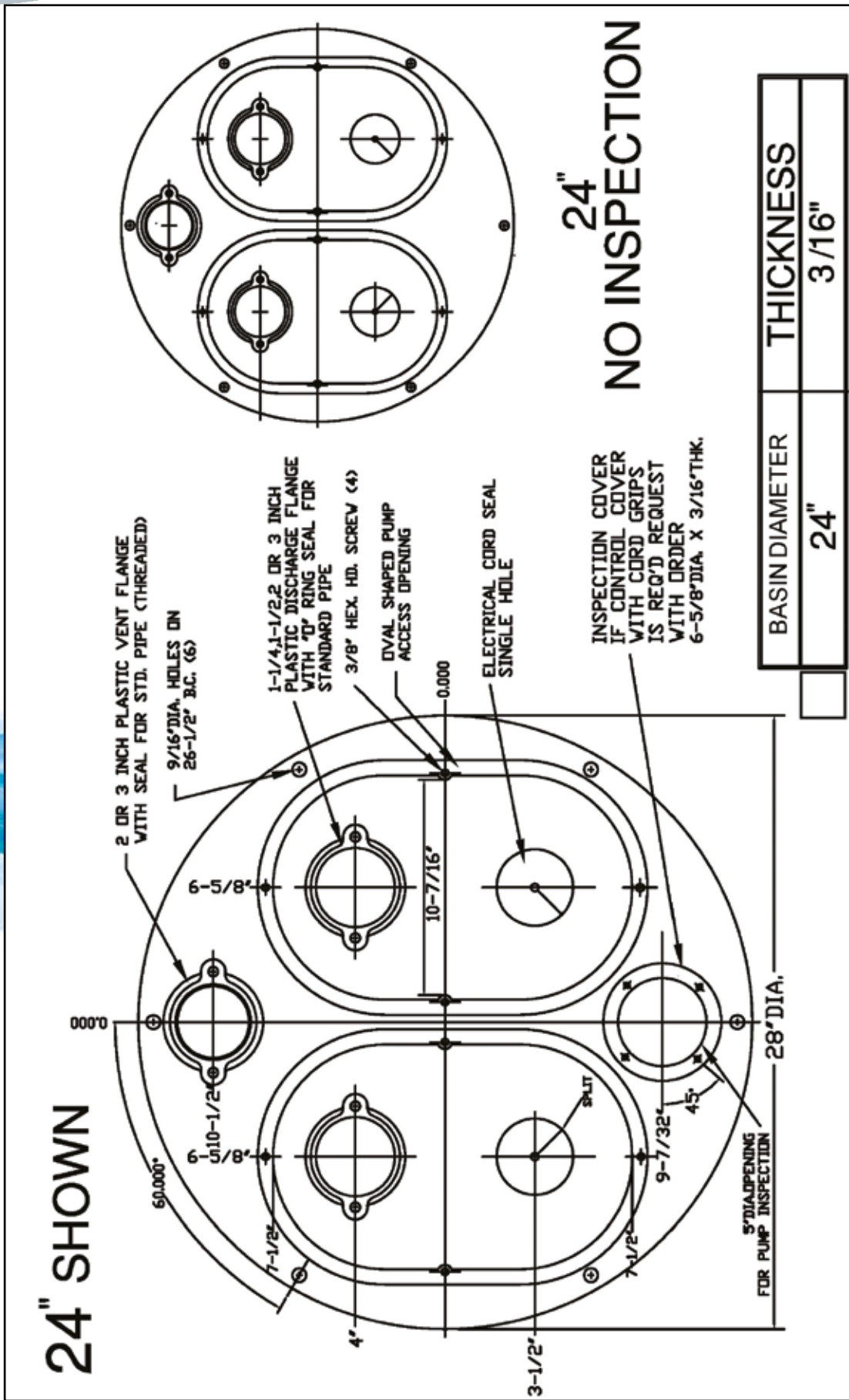

# 30" Fiberglass Duplex Covers

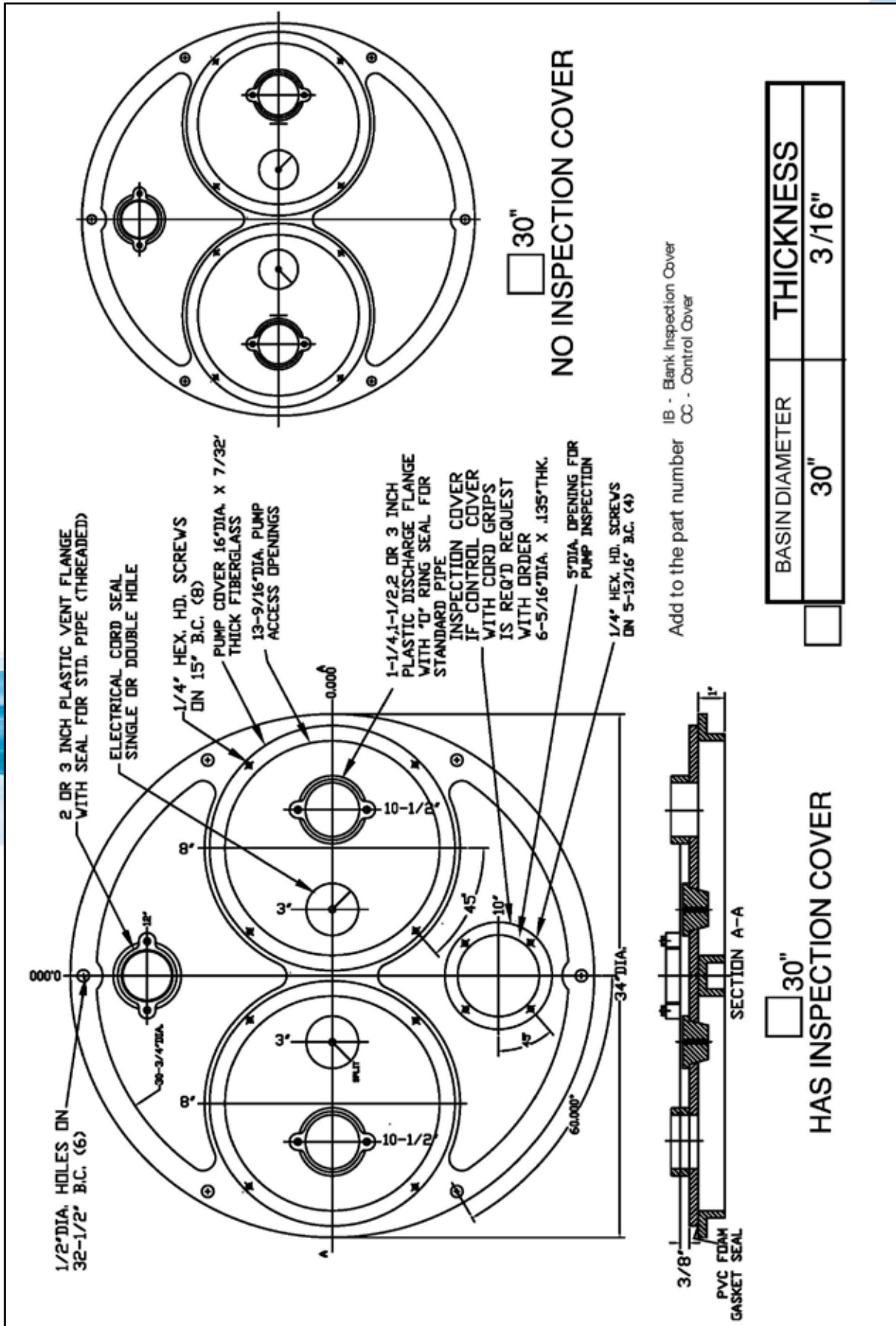



# Duplex Metal Covers

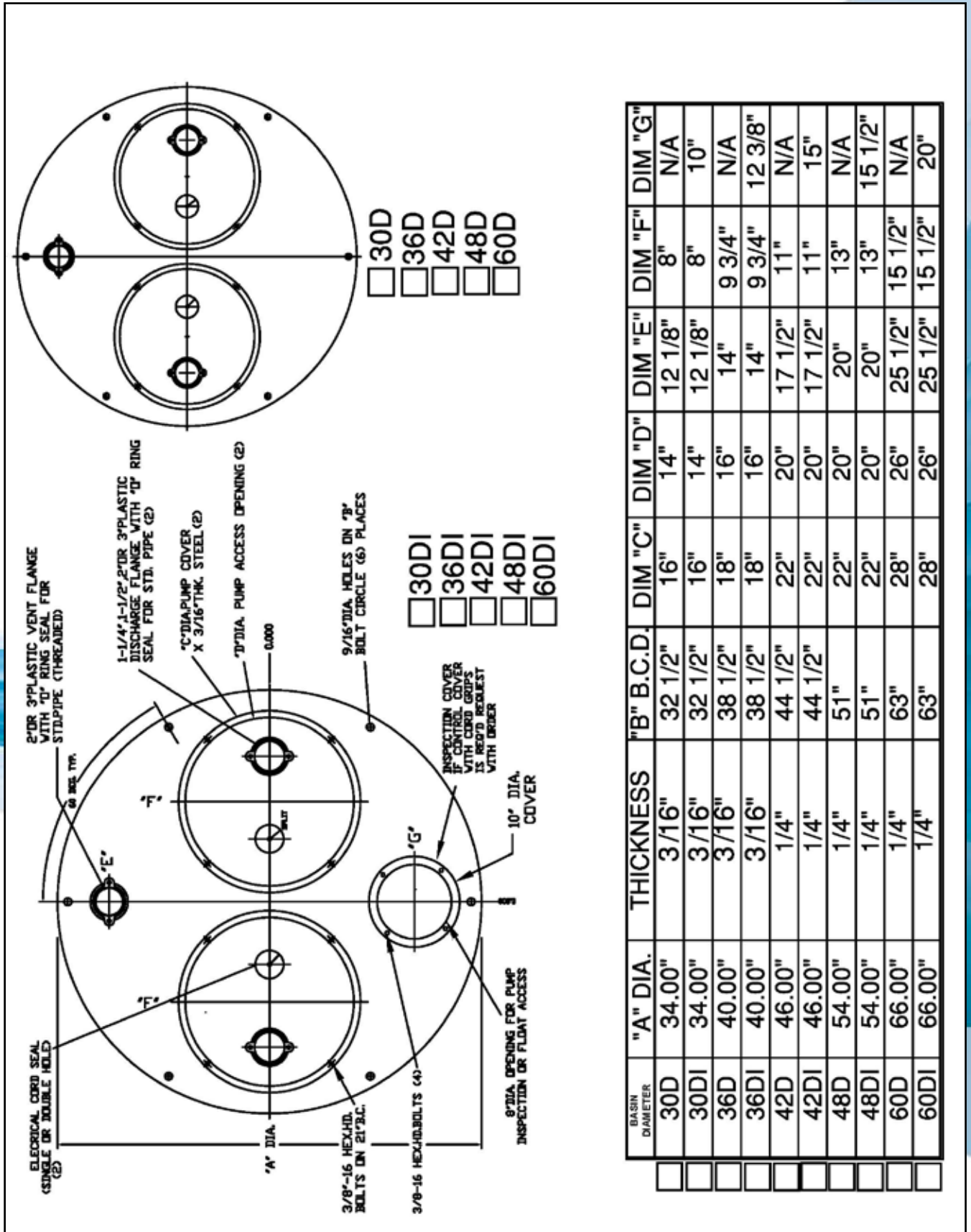

BASIN DIAMETER	"A" DIA.	THICKNESS	"B" B.C.D.	DIM "C"	DIM "D"	DIM "E"	DIM "F"	DIM "G"
30D	34.00"	3/16"	32 1/2"	16"	14"	12 1/8"	8"	N/A
30DI	34.00"	3/16"	32 1/2"	16"	14"	12 1/8"	8"	10"
36D	40.00"	3/16"	38 1/2"	18"	16"	14"	9 3/4"	N/A
36DI	40.00"	3/16"	38 1/2"	18"	16"	14"	9 3/4"	12 3/8"
42D	46.00"	1/4"	44 1/2"	22"	20"	17 1/2"	11"	N/A
42DI	46.00"	1/4"	44 1/2"	22"	20"	17 1/2"	11"	15"
48D	54.00"	1/4"	51"	22"	20"	20"	13"	N/A
48DI	54.00"	1/4"	51"	22"	20"	20"	13"	15 1/2"
60D	66.00"	1/4"	63"	28"	26"	25 1/2"	15 1/2"	N/A
60DI	66.00"	1/4"	63"	28"	26"	25 1/2"	15 1/2"	20"



# SIMPLEX SUBMERSIBLE

**PUMP INFORMATION**

- Type:  Sump Pump  
 Grinder Pump  
 Non-Clog Pump

Model NO: \_\_\_\_\_  
 Rating: \_\_\_\_\_ GPM \_\_\_\_\_ TDH  
 Motor: \_\_\_\_\_ HP \_\_\_\_\_ RPM  
 Elec: \_\_\_\_\_ PH \_\_\_\_\_ HZ \_\_\_\_\_  
 Elec: \_\_\_\_\_ FL AMPS

**DISCHARGE PIPE**

- 304 Stainless Steel  
 Sch40 Galvanized Steel  
 Sch80 PVC Pipe  
 1 1/4"  
 1 1/2"  
 2"  
 3"

**ANTI-FLOATATION FLANGE**

- Fiberglass Encapsulated  
 ASTM A-36 Steel  
 Round Fiberglass  
 None



- GAS TIGHT HATCH COVER**  
 Fiberglass  Aluminium  Steel

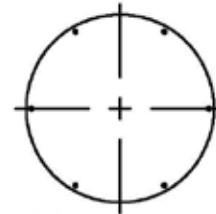

- SOLID COVER**  
 Fiberglass  
 Steel

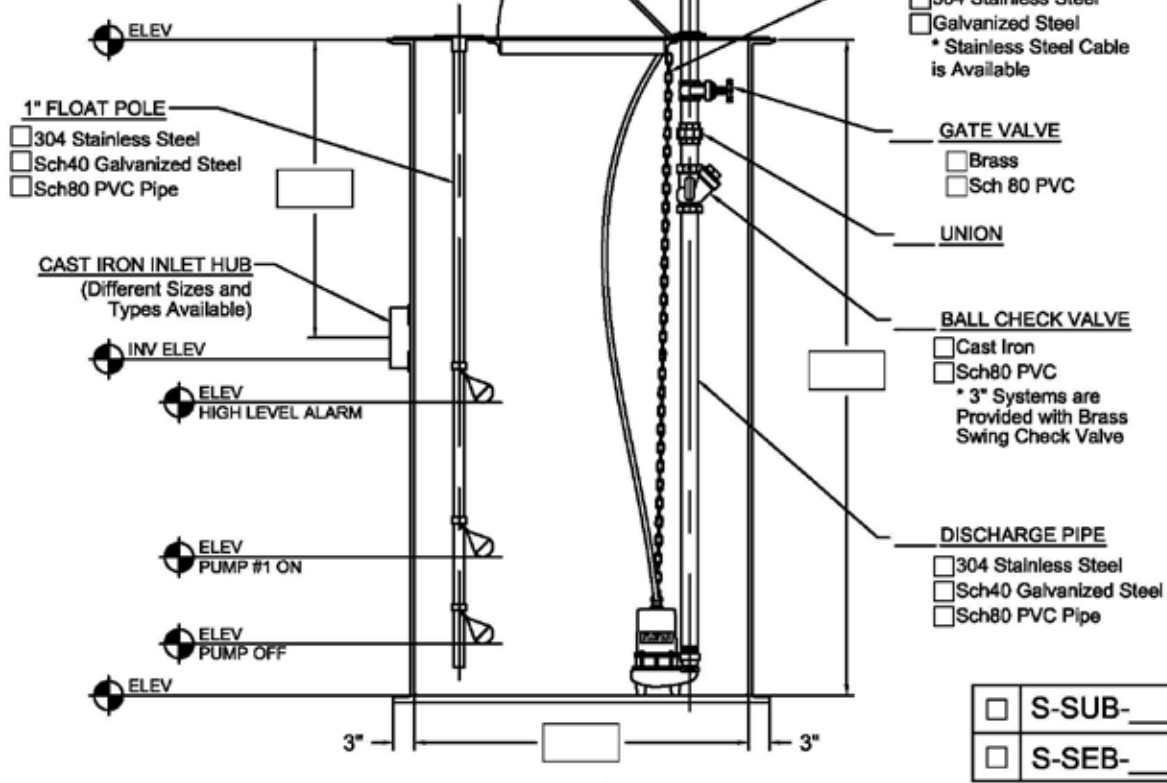
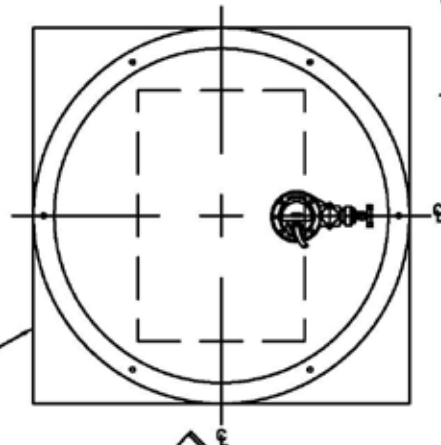

- 3/16" LIFTING CHAIN**  
 304 Stainless Steel  
 Galvanized Steel  
 \* Stainless Steel Cable is Available

- GATE VALVE**  
 Brass  
 Sch 80 PVC

**UNION**

- BALL CHECK VALVE**  
 Cast Iron  
 Sch80 PVC  
 \* 3" Systems are Provided with Brass Swing Check Valve

- DISCHARGE PIPE**  
 304 Stainless Steel  
 Sch40 Galvanized Steel  
 Sch80 PVC Pipe

S-SUB-\_\_\_\_\_  
 S-SEB-\_\_\_\_\_

<b>FLO FAB</b>			
<b>SIMPLEX SUBMERSIBLE</b>			
PROJECT/PROJET		DATE / DATE	
CUSTOMER / CLIENT		AUGUST 2007	
PART LIST N° / LISTE DE MATÉRIEL N°		DRAWING N° / N° Dessin	
MONTREAL (QC), CANADA TORONTO (ON), CANADA LAKE WORTH (FL), USA WWW.FLOFAB.COM		S-SUB-16737-FN	
DRAWN BY / DÉSIGNATEUR	SCALE / ÉCHELLE	DRAWING N° / N° Dessin	REV
M. LYMBURNER	N / A	S-SUB-16737-FN	0



# SIMPLEX SUBMERSIBLE

**PUMP INFORMATION**

- Type:  Sump Pump  
 Grinder Pump  
 Non-Clog Pump

Model NO: \_\_\_\_\_  
 Rating: \_\_\_\_\_ GPM \_\_\_\_\_ TDH  
 Motor: \_\_\_\_\_ HP \_\_\_\_\_ RPM  
 Elec: \_\_\_\_\_ PH \_\_\_\_\_ HZ \_\_\_\_\_ v  
 Elec: \_\_\_\_\_ FL AMPS

**DISCHARGE PIPE**

- 304 Stainless Steel  
 Sch40 Galvanized Steel  
 Sch80 PVC Pipe  
 1 1/4"  
 1 1/2"  
 2"  
 3"  
 4"

**ANTI-FLOATATION FLANGE**

- Fiberglass Encapsulated  
 ASTM A-36 Steel  
 Round Fiberglass  
 None

**1" FLOAT POLE**

- 304 Stainless Steel  
 Sch40 Galvanized Steel  
 Sch80 PVC Pipe

**CAST IRON INLET HUB**

(Different Sizes and Types Available)

INV ELEV  
 ELEV HIGH LEVEL ALARM

ELEV PUMP #1 ON

ELEV PUMP OFF

ELEV

3" ——— 3"

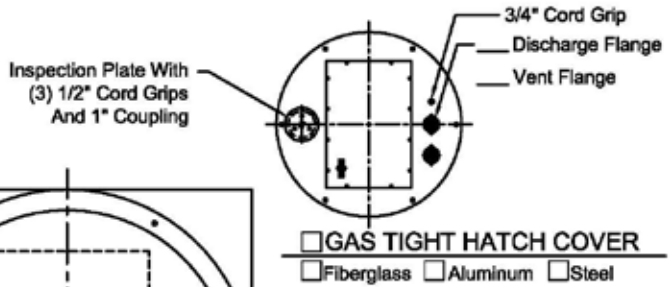

- 3/16" LIFTING CHAIN**  
 304 Stainless Steel  
 Galvanized Steel  
 \* Stainless Steel Cable is Available

- GATE VALVE**  
 Brass  
 Sch 80 PVC

- UNION**  
**BALL CHECK VALVE**  
 Cast Iron  
 Sch80 PVC  
 \* 3" Systems are Provided with Brass Swing Check Valve

- DISCHARGE PIPE**  
 304 Stainless Steel  
 Sch40 Galvanized Steel  
 Sch80 PVC Pipe

- SLIDE RAIL COUPLING**  
 BAF 2"  
 BAF 3"  
 BAF 4"

<input type="checkbox"/>	S-SUB-BAF-_____
<input type="checkbox"/>	S-SEB-BAF-_____

<b>FLO FAB</b>			
<b>SIMPLEX SUBMERSIBLE WITH SLIDE RAIL COUPLING</b>			
<p>MONTREAL (QC) CANADA                  TORONTO (ON), CANADA                  LAKE WORTH (FL), USA                  WWW.FLOFAB.COM</p>		PROJECT/PROJET	
		CUSTOMER/CLIENT	
DRAWN BY / DESIGNATEUR		DATE / DATE	
M. LYMBURNER		AUGUST 2007	
SCALE / ÉCHELLE		DRAWING NO. / N° DESSIN	
N/A		S-SUB-BAF-16739-FN	
		REV	
		0	



# SIMPLEX SUBMERSIBLE

**PUMP INFORMATION**

- Type:  Sump Pump  
 Grinder Pump  
 Non-Clog Pump

Model NO: \_\_\_\_\_  
 Rating: \_\_\_\_\_ GPM \_\_\_\_\_ TDH  
 Motor: \_\_\_\_\_ HP \_\_\_\_\_ RPM  
 Elec: \_\_\_\_\_ PH \_\_\_\_\_ HZ \_\_\_\_\_ v  
 Elec: \_\_\_\_\_ FL AMPS

**DISCHARGE PIPE**

- 304 Stainless Steel  
 Sch40 Galvanized Steel  
 Sch80 PVC Pipe  
 1 1/4"  
 1 1/2"  
 2"  
 3"

**ANTI-FLOATATION FLANGE**

- Fiberglass Encapsulated  
 ASTM A-36 Steel  
 Round Fiberglass  
 None

**304 STAINLESS STEEL  
 FLOAT BRACKET WITH  
 (3) CORD GRIPS**  
 Floats

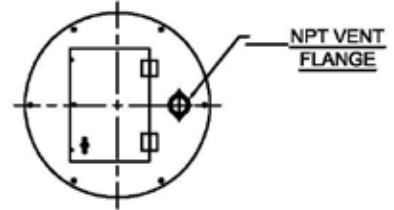

- HINGED AND LOCKABLE COVER**  
 Fiberglass  Aluminum  Steel

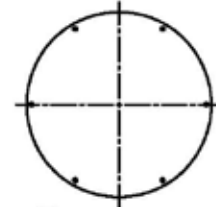

- SOLID COVER**  
 Fiberglass  
 Steel

**NPT ELECTRICAL COUPLING**

- Enameled Steel  
 Stainless Steel

**INLET GROMMET**  
 (Different Sizes and  
 Types Available)

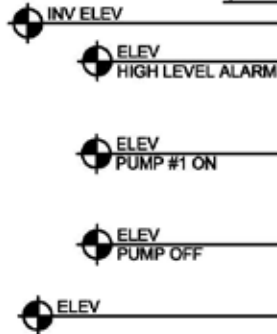

**3/8" 304 STAINLESS STEEL VALVE  
 EXTENSION HANDLE**

- 3/16" LIFTING CHAIN**  
 304 Stainless Steel  
 Galvanized Steel  
 \* Stainless Steel Cable is Available

**GATE VALVE**

- Brass  
 Sch 80 PVC

**INV ELEV**

**NPT DISCHARGE COUPLING**

- Enameled Steel  
 Stainless Steel

**UNION**

**BALL CHECK VALVE**

- Cast Iron  
 Sch80 PVC  
 \* 3" Systems are Provided with Brass Swing Check Valve

**DISCHARGE PIPE**

- 304 Stainless Steel  
 Sch40 Galvanized Steel  
 Sch80 PVC Pipe

3" 3"

- S-SUB- \_\_\_\_\_  
 S-SEB- \_\_\_\_\_

<p>TITLE / DATE</p> <p align="center"><b>FLO FAB SIMPLEX SUBMERSIBLE</b></p>			
<p>PROJECT / CLIENT</p>		<p>CUSTOMER / CLIENT</p>	
<p>MONTREAL, (QC), CANADA                  TORONTO, (ON), CANADA                  LAKE WORTH, (FL), USA                  WWW.FLOFAB.COM</p>		<p>PART LIST N° / LISTE DE MATERIEL N°</p>	<p>DATE / DATE</p> <p align="center"><b>AUGUST 2007</b></p>
<p>DRAWN BY / DESIGNATEUR</p> <p><b>M. LYMBURNER</b></p>	<p>SCALE / ECHELLE</p> <p align="center"><b>N/A</b></p>	<p>DRAWING N° / N° Dessin</p> <p align="center"><b>S-SUB-10148-EN</b></p>	<p>REV</p> <p align="center"><b>0</b></p>



# SIMPLEX SUBMERSIBLE

**PUMP INFORMATION**

- Type:  Sump Pump  
 Grinder Pump  
 Non-Clog Pump

Model NO: \_\_\_\_\_  
 Rating: \_\_\_\_\_ GPM \_\_\_\_\_ TDH  
 Motor: \_\_\_\_\_ HP \_\_\_\_\_ RPM  
 Elec: \_\_\_\_\_ PH \_\_\_\_\_ HZ \_\_\_\_\_ v  
 Elec: \_\_\_\_\_ FL AMPS

**DISCHARGE PIPE**

- 304 Stainless Steel  
 Sch40 Galvanized Steel  
 Sch80 PVC Pipe

- ANTI-FLOATATION FLANGE  
 1 1/4"  
 1 1/2"  
 2"  
 3"  
 4"  
 Fiberglass Encapsulated ASTM A-36 Steel  
 Round Fiberglass  
 None

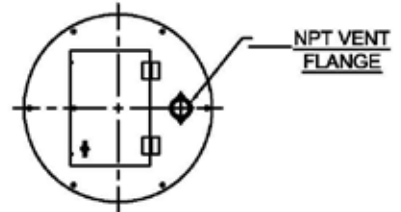

- GAS TIGHT HATCH COVER  
 HINGED AND LOCKABLE COVER  
 Fiberglass  Aluminum  Steel

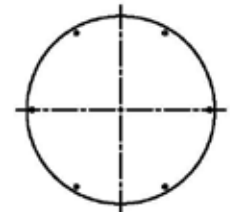

- SOLID COVER  
 Fiberglass  
 Steel

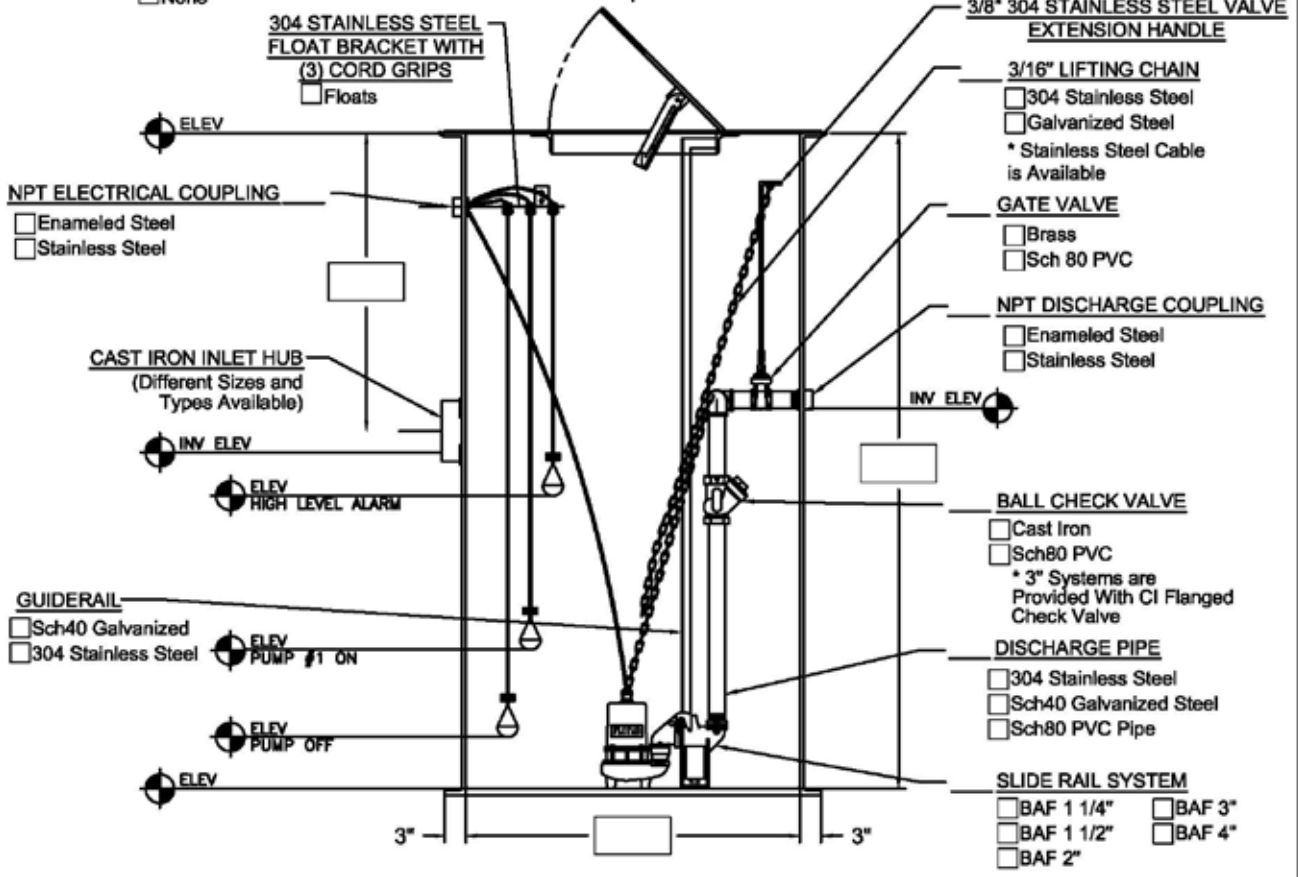
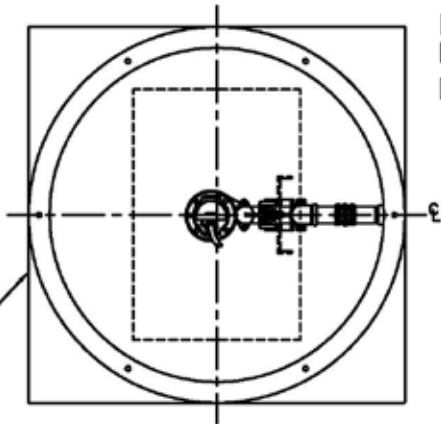

TITLE / TITRE <b>FLO FAB</b> SIMPLEX SUBMERSIBLE WITH SLIDE RAIL COUPLING			
PROJECT / PROJET _____		CUSTOMER / CLIENT _____	
PART LIST N° / LISTE DE MATRIEL N° _____		DATE / DATE AUGUST 2007	
DRAWN BY / D'ORIGINEUR M. LYMBURNER		SCALE / ECHELLE N / A	
DRAWING N° / N° DESSIN S-SUB-BAF-16736-EN		REV 0	

- S-SUB-BAF-\_\_\_\_\_  
 S-SEB-BAF-\_\_\_\_\_



# SIMPLEX SUBMERSIBLE

**PUMP INFORMATION**

- Type:  Sump Pump  
 Grinder Pump  
 Non-Clog Pump

Model NO: \_\_\_\_\_  
 Rating: \_\_\_\_\_ GPM \_\_\_\_\_ TDH  
 Motor: \_\_\_\_\_ HP \_\_\_\_\_ RPM  
 Elec: \_\_\_\_\_ PH \_\_\_\_\_ HZ \_\_\_\_\_ v  
 Elec: \_\_\_\_\_ FL AMPS

**DISCHARGE PIPE**

- 304 Stainless Steel  
 Sch40 Galvanized Steel  
 Sch80 PVC Pipe  
 1 1/4"  
 1 1/2"  
 2"  
 3"

**ANTI-FLOATATION FLANGE**

- Fiberglass Encapsulated  
 ASTM A-36 Steel  
 Round Fiberglass  
 None

**304 STAINLESS STEEL  
 FLOAT BRACKET WITH  
 (3) CORD GRIPS**  
 Floats

**NPT ELECTRICAL COUPLING**

- Enameled Steel  
 Stainless Steel

**INLET GROMMET**  
 (Different Sizes and  
 Types Available)

**GUIDERAIL**

- Sch40 Galvanized  
 304 Stainless Steel

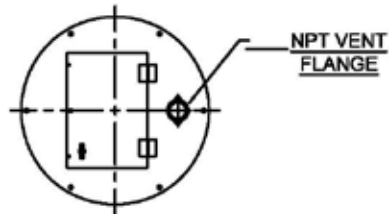

**HINGED AND LOCKABLE COVER**

- Fiberglass  Aluminum  Steel

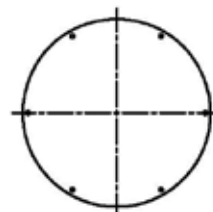

**SOLID COVER**

- Fiberglass  
 Steel

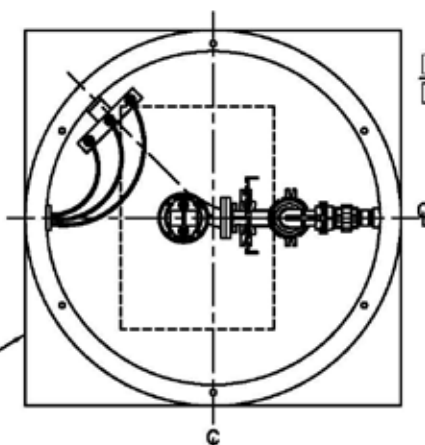

**3/8" 304 STAINLESS STEEL VALVE  
 EXTENSION HANDLE**

**3/16" LIFTING CHAIN**

- 304 Stainless Steel  
 Galvanized Steel  
 \* Stainless Steel Cable  
 is Available

**GATE VALVE**

- Brass  
 Sch 80 PVC

**UNION**

**NPT DISCHARGE COUPLING**

- Enameled Steel  
 Stainless Steel

**BALL CHECK VALVE**

- Cast Iron  
 Sch80 PVC  
 \* 3" Systems are  
 Provided with Brass  
 Swing Check Valve

**DISCHARGE PIPE**

- 304 Stainless Steel  
 Sch40 Galvanized Steel  
 Sch80 PVC Pipe

**SLIDE RAIL SYSTEM**

- BAF 3"  
 BAF 4"

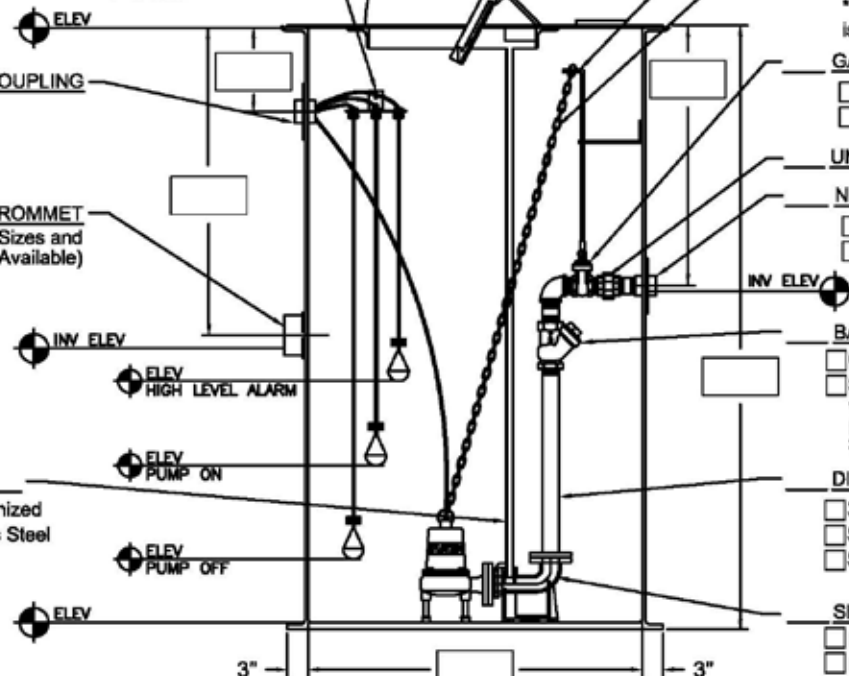

- S-SUB-BAF-\_\_\_\_\_  
 S-SEB-BAF-\_\_\_\_\_

<p><b>FLO FAB</b>                  SIMPLEX SUBMERSIBLE</p>			
<p>PROJECT/PROJECT</p>			
<p>CUSTOMER/CLIENT</p>			
<p>PART LIST # / LIBRE DE MATRIEL #</p>		<p>DATE / DATE</p>	
<p>DRAWN BY / DESIGNATEUR</p>		<p>SCALE / ECHELLE</p>	
<p>M. LYMBURNER</p>		<p>N/A</p>	
<p>DATE / DATE</p>		<p>AUGUST 2007</p>	
<p>DRAWING # / N° DESEN</p>		<p>S-SUB-10144-FN</p>	



# SIMPLEX SUBMERSIBLE

**PUMP INFORMATION**

- Type:  Sump Pump  
 Grinder Pump  
 Non-Clog Pump
- Model NO: \_\_\_\_\_
- Rating: \_\_\_\_\_ GPM \_\_\_\_\_ TDH
- Motor: \_\_\_\_\_ HP \_\_\_\_\_ RPM
- Elec: \_\_\_\_\_ PH \_\_\_\_\_ HZ \_\_\_\_\_ v
- Elec: \_\_\_\_\_ FL AMPS

**DISCHARGE PIPE**

- 304 Stainless Steel  
 Sch40 Galvanized Steel  
 Sch80 PVC Pipe  
 3"  
 4"

**ANTI-FLOATATION FLANGE**

- Fiberglass Encapsulated  
 ASTM A-36 Steel  
 Round Fiberglass  
 None

**1" FLOAT POLE**

- 304 Stainless Steel  
 Sch40 Galvanized Steel  
 Sch80 PVC Pipe

**CAST IRON INLET HUB**  
 (Different Sizes and Types Available)

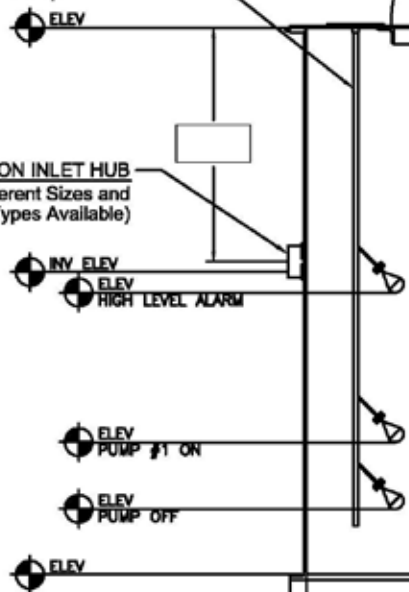

Inspection Plate With  
 (4) 1/2" Cord Grips  
 And 1" Coupling

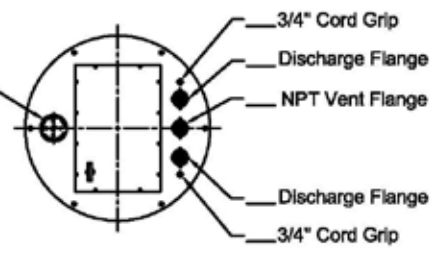
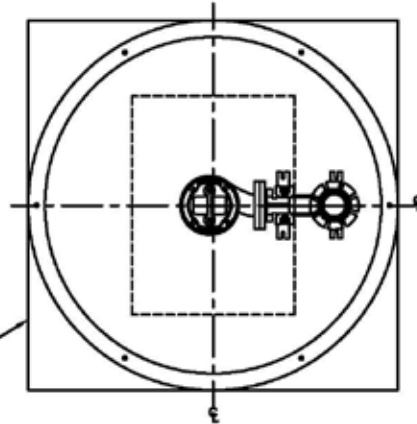

**GAS TIGHT HATCH COVER**  
 Fiberglass  Aluminum  Steel

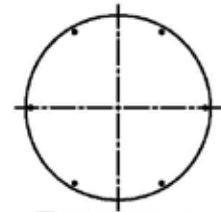

**SOLID COVER**  
 Fiberglass  
 Steel

**DISCHARGE PIPE**

- 304 Stainless Steel  
 Sch40 Galvanized Steel  
 Sch80 PVC Pipe

**3/16" LIFTING CHAIN**

- 304 Stainless Steel  
 Galvanized Steel  
 \* Stainless Steel Cable is Available

**PLUG VALVE**

- \*Gate Valves Also Available  
 3"  
 4"

**CAST IRON SWING CHECK VALVE**

- 3"  
 4"

**GUIDERAIL**

- Sch40 Galvanized  
 304 Stainless Steel

**SLIDE RAIL FLANGE**

- BAF 3"  
 BAF 4"

S-SUB-BAF-\_\_\_\_\_

S-SEB-BAF-\_\_\_\_\_

<b>FLO FAB</b>			
<b>SIMPLEX SUBMERSIBLE WITH SLIDE RAIL COUPLING</b>			
		PROJECT/PROJ.#	
MONTREAL (QC), CANADA TORONTO (ON), CANADA LAKE WORTH (FL), USA WWW.FLOFAB.COM		CUSTOMER / CLIENT	
DRAWN BY / DESIGNATEUR		DATE / DATE	
M. LYMBURNER		AUGUST 2007	
SCALE / ÉCHELLE		PART LIST # / LISTE DE MATÉRIEL #	
N/A		D-SUB-BAF-16845-FN	
DRAWING # / N° DE Dessin		REV	
		0	



# DUPLEX SUBMERSIBLE

**PUMP INFORMATION**

- Type:  Sump Pump(s)  
 Grinder Pump(s)  
 Non-Clog Pump(s)

Model NO: \_\_\_\_\_  
 Rating: \_\_\_\_\_ GPM \_\_\_\_\_ TDH  
 Motor: \_\_\_\_\_ HP \_\_\_\_\_ RPM  
 Elec: \_\_\_\_\_ PH \_\_\_\_\_ HZ \_\_\_\_\_ v  
 Elec: \_\_\_\_\_ FL AMPS

**DISCHARGE PIPE**

- 304 Stainless Steel  
 Sch40 Galvanized Steel  
 Sch80 PVC Pipe  
 1 1/4"  
 1 1/2"  
 2"  
 3"

**ANTI-FLOATATION FLANGE**

- Fiberglass Encapsulated  
 ASTM A-36 Steel  
 Round Fiberglass  
 None

Inspection Plate With  
 (4) 1/2" Cord Grips  
 And 1" Coupling

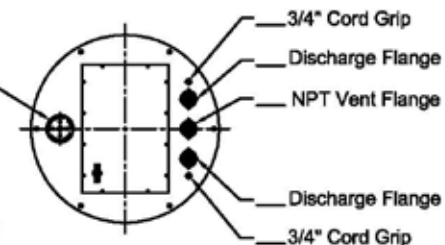

**GAS TIGHT HATCH COVER**

- Fiberglass  Aluminum  Steel

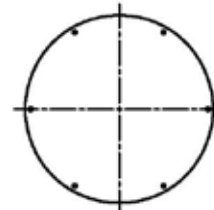

**SOLID COVER**

- Fiberglass  
 Steel

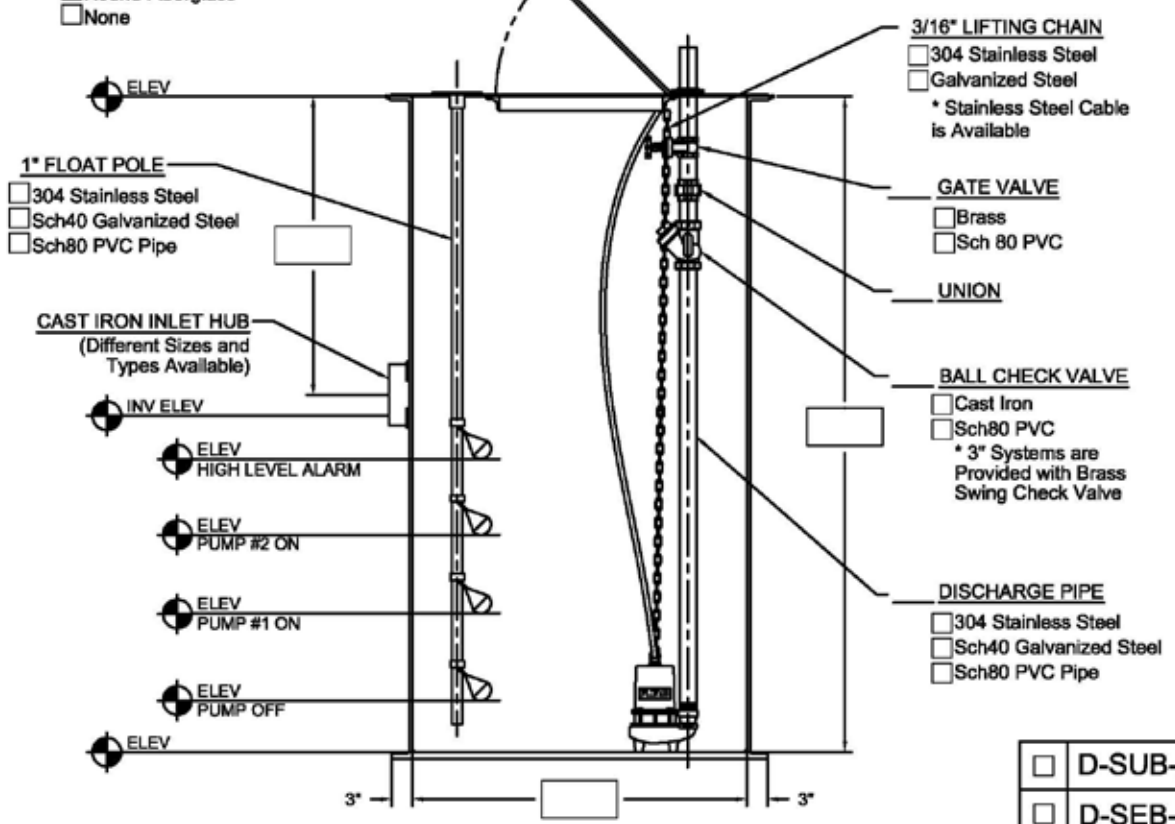

- 1" FLOAT POLE**  
 304 Stainless Steel  
 Sch40 Galvanized Steel  
 Sch80 PVC Pipe

**CAST IRON INLET HUB**  
 (Different Sizes and  
 Types Available)

- ELEV
- INV ELEV
- ELEV HIGH LEVEL ALARM
- ELEV PUMP #2 ON
- ELEV PUMP #1 ON
- ELEV PUMP OFF
- ELEV

- 3/16" LIFTING CHAIN**  
 304 Stainless Steel  
 Galvanized Steel  
 \* Stainless Steel Cable  
 is Available

- GATE VALVE**  
 Brass  
 Sch 80 PVC

**UNION**

- BALL CHECK VALVE**  
 Cast Iron  
 Sch80 PVC  
 \* 3" Systems are  
 Provided with Brass  
 Swing Check Valve

- DISCHARGE PIPE**  
 304 Stainless Steel  
 Sch40 Galvanized Steel  
 Sch80 PVC Pipe

D-SUB-\_\_\_\_\_  
 D-SEB-\_\_\_\_\_

TITLE / TITRE <b>FLO FAB                  DUPLEX SUBMERSIBLE</b>			
PROJECT / PROJET _____		DATE / DATE <b>AUGUST 2007</b>	
CUSTOMER / CLIENT _____		PART LIST N° / LISTE DE MATERIEL N° _____	
DRAWN BY / DESIGNATEUR <b>M. LYMBURNER</b>		SCALE / ECHELLE <b>N / A</b>	
MONTREAL (QC), CANADA TORONTO (ON), CANADA LAKE WORTH (FL), USA WWW.FLOFAB.COM		DRAWING N° / N° CESSON <b>D-SUB-17506-EN</b>	





# DUPLEX SUBMERSIBLE

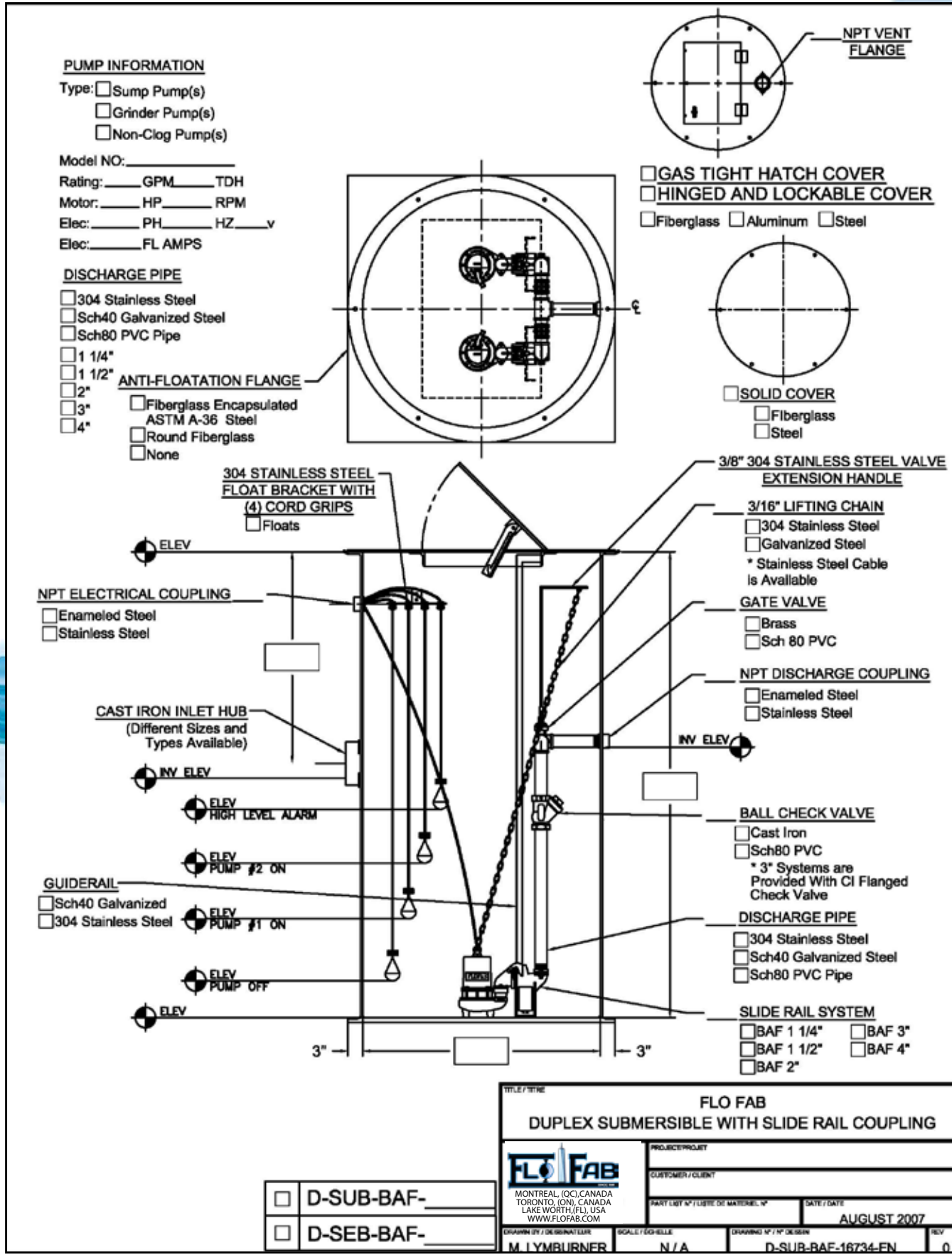

- D-SUB-BAF-\_\_\_\_\_
- D-SEB-BAF-\_\_\_\_\_

<b>FLO FAB</b> DUPLEX SUBMERSIBLE WITH SLIDE RAIL COUPLING			
		PROJECT/PROJET	
MONTREAL (QC), CANADA TORONTO (ON), CANADA LAKE WORTH (FL), USA WWW.FLOFAB.COM		CUSTOMER / CLIENT	
PART LIST N° / LISTE DE MATERIEL N°		DATE / DATE	
AUGUST 2007		SCALE / ÉCHELLE	
DRAWING BY / DÉSIGNATEUR		DRAWING N° / N° DE Dessin	
M. LYMBURNER		N/A	
D-SUB-BAF-16734-FN		REV	



# DUPLEX SUBMERSIBLE

**PUMP INFORMATION**

- Type:  Sump Pump(s)  
 Grinder Pump(s)  
 Non-Clog Pump(s)

Model NO: \_\_\_\_\_  
 Rating: \_\_\_\_\_ GPM \_\_\_\_\_ TDH  
 Motor: \_\_\_\_\_ HP \_\_\_\_\_ RPM  
 Elec: \_\_\_\_\_ PH \_\_\_\_\_ HZ \_\_\_\_\_ v  
 Elec: \_\_\_\_\_ FL AMPS

**DISCHARGE PIPE**

- 304 Stainless Steel  
 Sch40 Galvanized Steel  
 Sch80 PVC Pipe  
 1 1/4"  
 1 1/2"  
 2"  
 3"  
 4"

**ANTI-FLOATATION FLANGE**

- Fiberglass Encapsulated  
 ASTM A-36 Steel  
 Round Fiberglass  
 None

Inspection Plate With  
 (4) 1/2" Cord Grips  
 And 1" Coupling

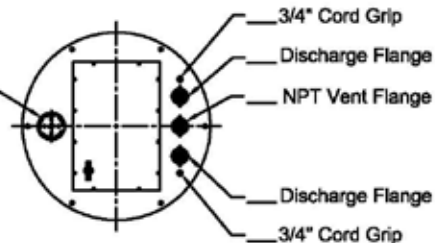

**GAS TIGHT HATCH COVER**

- Fiberglass  Aluminum  Steel

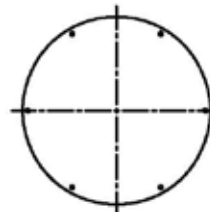

**SOLID COVER**

- Fiberglass  
 Steel

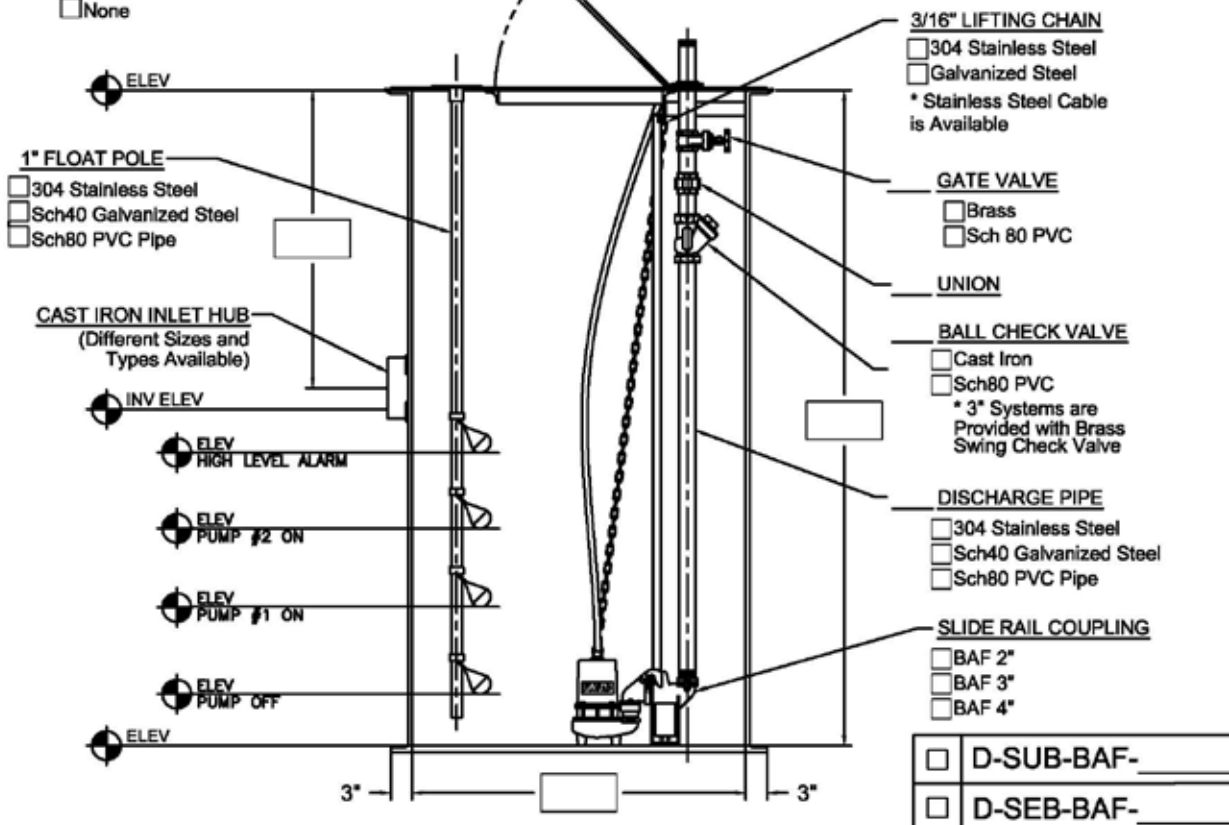

- 3/16" LIFTING CHAIN**  
 304 Stainless Steel  
 Galvanized Steel  
 \* Stainless Steel Cable is Available

- GATE VALVE**  
 Brass  
 Sch 80 PVC

- UNION**  
**BALL CHECK VALVE**  
 Cast Iron  
 Sch80 PVC  
 \* 3" Systems are Provided with Brass Swing Check Valve

- DISCHARGE PIPE**  
 304 Stainless Steel  
 Sch40 Galvanized Steel  
 Sch80 PVC Pipe

- SLIDE RAIL COUPLING**  
 BAF 2"  
 BAF 3"  
 BAF 4"

- D-SUB-BAF-\_\_\_\_\_  
 D-SEB-BAF-\_\_\_\_\_

TITLE / TITRE <b>FLO FAB</b> DUPLEX SUBMERSIBLE WITH SLIDE AWAY COUPLING	
PROJECT / PROJET	
CUSTOMER / CLIENT	
PART LIST N° / LISTE DE MATÉRIEL N°	DATE / DATE AUGUST 2007
DRAWN BY / DÉSSINATEUR M. LYMBURNER	SCALE / ÉCHELLE N / A
DRAWING N° / N° DESSIN D-SUB-BAF-16735-EN	REV 0



# DUPLEX SUBMERSIBLE

**PUMP INFORMATION**

- Type:  Sump Pump(s)  
 Grinder Pump(s)  
 Non-Clog Pump(s)

Model NO: \_\_\_\_\_  
 Rating: \_\_\_\_\_ GPM \_\_\_\_\_ TDH  
 Motor: \_\_\_\_\_ HP \_\_\_\_\_ RPM  
 Elec: \_\_\_\_\_ PH \_\_\_\_\_ HZ \_\_\_\_\_ v  
 Elec: \_\_\_\_\_ FL AMPS

**DISCHARGE PIPE**

- 304 Stainless Steel  
 Sch40 Galvanized Steel  
 Sch80 PVC Pipe  
 3"  
 4"

**ANTI-FLOATATION FLANGE**

- Fiberglass Encapsulated  
 ASTM A-36 Steel  
 Round Fiberglass  
 None

**1" FLOAT POLE**

- 304 Stainless Steel  
 Sch40 Galvanized Steel  
 Sch80 PVC Pipe

**CAST IRON INLET HUB**  
 (Different Sizes and Types Available)

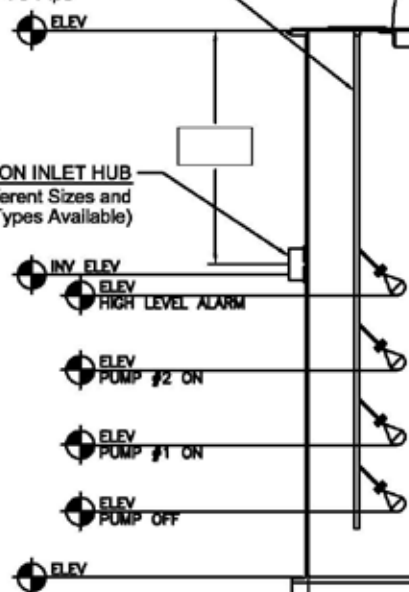

Inspection Plate With  
 (4) 1/2" Cord Grips  
 And 1" Coupling

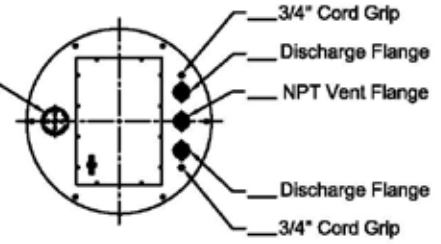
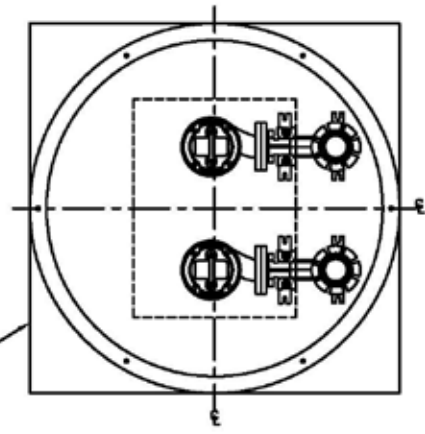

**GAS TIGHT HATCH COVER**

- Fiberglass  Aluminum  Steel



**DISCHARGE PIPE**

- 304 Stainless Steel  
 Sch40 Galvanized Steel  
 Sch80 PVC Pipe

**3/16" LIFTING CHAIN**

- 304 Stainless Steel  
 Galvanized Steel  
 \* Stainless Steel Cable is Available

**PLUG VALVE**

- \*Gate Valves Also Available  
 3"  
 4"

**CAST IRON SWING CHECK VALVE**

- 3"  
 4"

**GUIDERAIL**

- Sch40 Galvanized  
 304 Stainless Steel

**SLIDE RAIL FLANGE**

- BAF 3"  
 BAF 4"

- D-SUB-BAF-\_\_\_\_\_  
 D-SEB-BAF-\_\_\_\_\_

<p>TITLE / TITRE  <b>FLO FAB</b>                  DUPLEX SUBMERSIBLE WITH SLIDE RAIL COUPLING</p>			
<p>PROJECT/PROJET</p>		<p>CUSTOMER / CLIENT</p>	
<p>MONTREAL (QC) CANADA                  TORONTO (ON) CANADA                  LAKE WORTH (FL) USA                  WWW.FLOFAB.COM</p>		<p>PART LIST N° / LISTE DES MATÉRIELS N°</p>	
<p>DATE / DATE</p>		<p>AUGUST 2007</p>	
<p>DRAWN BY / DÉSIGNATEUR                  M. LYMBURNER</p>	<p>SCALE / ÉCHELLE                  N/A</p>	<p>DRAWING N° / N° DESIGN                  D-SUB-BAF-16844-EN</p>	<p>REV</p>



# DUPLEX SUBMERSIBLE

**PUMP INFORMATION**

- Type:  Sump Pump(s)
- Grinder Pump(s)
- Non-Clog Pump(s)

Model NO: \_\_\_\_\_  
 Rating: \_\_\_\_\_ GPM \_\_\_\_\_ TDH  
 Motor: \_\_\_\_\_ HP \_\_\_\_\_ RPM  
 Elec: \_\_\_\_\_ PH \_\_\_\_\_ HZ \_\_\_\_\_ V  
 Elec: \_\_\_\_\_ FL AMPS

**DISCHARGE PIPE**

- 304 Stainless Steel
- Sch40 Galvanized Steel
- Sch80 PVC Pipe
- 2"
- 3"
- 4"

**ANTI-FLOTATION FLANGE**

- Fiberglass Encapsulated ASTM A-36 Steel
- Round Fiberglass
- None

**304 STAINLESS STEEL FLOAT BRACKET WITH (4) CORD GRIPS**  
 Floats

**NPT ELECTRICAL COUPLING**  
 Enameled Steel  
 Stainless Steel

**INLET GROMMET**  
 (Different Sizes and Types Available)

**GUIDERAIL**  
 Sch40 Galvanized  
 304 Stainless Steel

**ELEV**

**INV ELEV**

**ELEV HIGH LEVEL ALARM**

**ELEV PUMP #2 ON**

**ELEV PUMP #1 ON**

**ELEV PUMP OFF**

3"

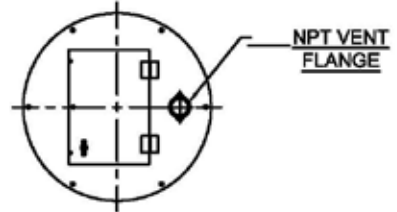

**HINGED AND LOCKABLE COVER**  
 Fiberglass  Aluminum  Steel

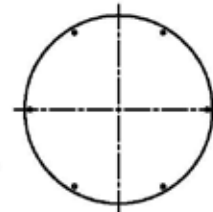

**SOLID COVER**  
 Fiberglass  
 Steel

**3/8" 304 STAINLESS STEEL VALVE EXTENSION HANDLE**

**3/16" LIFTING CHAIN**  
 304 Stainless Steel  
 Galvanized Steel  
 \* Stainless Steel Cable is Available

**GATE VALVE**  
 Brass  
 Sch 80 PVC

**UNION**  
**NPT DISCHARGE COUPLING**  
 Enameled Steel  
 Stainless Steel

**BALL CHECK VALVE**  
 Cast Iron  
 Sch80 PVC  
 \* 3" Systems are Provided with Brass Swing Check Valve

**DISCHARGE PIPE**  
 304 Stainless Steel  
 Sch40 Galvanized Steel  
 Sch80 PVC Pipe

**SLIDE RAIL SYSTEM**  
 BAF 3"  
 BAF 4"

**OPTION**

- 3"
- 4"

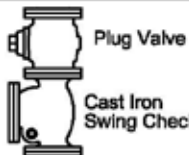

- D-SUB-BAF-** \_\_\_\_\_
- D-SEB-BAF-** \_\_\_\_\_

TITLE / TITRE <b>FLO FAB</b> <b>DUPLEX SUBMERSIBLE WITH SLIDE RAIL COUPLING</b>	
PRODUCED BY <b>FLO FAB</b>	PROJECT / PROJET
MONTREAL (QC) CANADA TORONTO (ON), CANADA LAKE WORTH (FL), USA WWW.FLOFAB.COM	CUSTOMER / CLIENT
PART LIST N° / LISTE DE MATERIEL N°	DATE / DATE <b>AUGUST 2007</b>
DRAWN BY / DESINATEUR M. LYMBURNER	SCALE / ECHELLE N.F.A.
DRAWING N° / N° DESSIN D-SUB-40101-EN	REV



## Standard for Simplex Submersible Panels

A NEMA 1 enclosure, including a main disconnect switch, one set of HRC fuses for short-circuit protection, one magnetic starter, one transformer with primary and secondary fuses (for system other than 120v), 120v control circuit, provision to connect three N.O. floats (FL1: stop float, FL2: pump start, FL3: high water level), one "Hand Off Auto" selector switch, "Power on", "Pump run", "High water level" pilot lights, audible alarm with silencer and test and dry contact for remote alarm.

NEMA Type 1  
General Purpose

To prevent accidental contact with enclosed apparatus. Suitable for application Indoors, where not exposed to unusual service conditions.

NEMA Type 2  
Driptight

To prevent accidental contact with enclosed apparatus. Excludes falling moisture or dirt.

NEMA Type 4  
Watertight

Designed to exclude water applied in form of hose stream. To protect against steam of water during cleaning operations, etc.

NEMA Type 4X  
Corrosion  
Resistant

Designed to exclude water supplied in form of hose stream and used in areas where serious corrosion problem exists.

NEMA Type 12  
Industrial Use

Excludes dust, lint, fibers and flyings or oil or coolant seepage.

## SUBMERSIBLES



# Standard for Simplex Submersible Panels

OPT#	DESCRIPTION
1	Enclosure Eemac/Nema 2 – Indoor – Falling water & light splashing
2	Inner door for tamper proofing any enclosure
3	Enclosure Eemac/Nema 12 – Dust tight
4	Enclosure Eemac/Nema 4 – Outdoor – Protection against hose directed water
4A	Enclosure Eemac/Nema 4X – Same as Item 4 but fibreglass corrosion proof
4B	Enclosure Eemac/Nema 4X – Same as item 4 but stainless steel painted corrosion proof (brushed finish available)
5	Alarm relay for remote indication
6	Alarm block (buzzer-silence selector-pilot light)
6A	Alarm block – as above but with silence push button
7	Motor overload (over current) indication per pump (pilot light)
7A	As above but with dry contact for remote indication
8	Seal leak fault per pump (conductivity relay with pilot light)
8A	As above but with dry contact for remote indication
9	Motor overheat fault indication per pump (pilot light)
9A	As above but with dry contact for remote indication
10	Pilot light for various function
11	Alarm bell
12	Elapsed time meter (Nema 1) per pump
13	Intrinsic safe relay (use when floats or electrodes are located in explosive medium)
14	Pump control using conductivity relay and electrodes
15	Loss of phase fault indication (pilot light) on incoming power (use with 3 phase supply)
17	Globe alarm (25 watt-non flashing-shatter proof)
18	Pump protection with breaker on single phase system - Max. 40 Amps - (branch circuit protection device rated – Type E rating)
19	Heater element + thermostat
22	Installation of capacitor pack in panel (for starting single phase pump)
24	Fault indication (Relay + pilot light)
31	Stop/Start with one float
32	Stop/Start with two floats
35	120V Supply for external load (Specify load)
36	Emergency stop push button
38	Low level indication (pilot light)
38A	Low level indication – shutdown with remote indication
39	Low low level indication (pilot light)
39A	Low low level indication – shut down with remote indication
40	Additional stop-start push button per pump
41	Provision for connection of solenoid
43	Remote start/stop signal
43A	24 Volt start signal
44	Lamp test push button
44A	Push to test push button
46	On delay timer (use to avoid nuisance tripping on certain faults)
47	Off delay timer



## SUBMERSIBLES

# Standard for Simplex Submersible Panels

OPT#	DESCRIPTION
48	Two positions selector
55	Indication only of pump failure to start
60	Float failure alarm
63	Ammeter – CT operated – for one pump
64	Voltmeter for system voltage – Direct read
65	Pump stop indication
67	Fault with latching relay and reset button
68	Remote signal for low of power
69	Current detection relay per pump (to confirm pump running)
70	Loss of phase and phase reversal detection and indication (three phase system)
72	Timer for minimum run
73	Timer for maximum run
74	General alarm indication with relay
77	Lightning arrestor
78	Extra for flashing function on pilot light or globe
79	Ground fault indication with pilot light (no stopping of pump)
80	Duplex receptacle – 120 V – 100Watts
81	Motor circuit interrupter (instead of fuses) – Max. 40 Amps – Rated as branch circuit protection device – Type E
81A	Moulded case circuit protector (replaces fuses)
82	Repeat cycle timer
84	Telephone dialler with battery back-up
85	Push button for misc. sequence (describe sequence)
86	Alarm high level
87	Pump start counter
88	Variable freq. drive for variable speed pumps
89	Line or load reactor for above
91	Stop pump on low level in manual mode
93	Horn
95	Auto reset of latched faults on resumption of power
99	Blown fuse indication for single phase system
101A	Circuit breaker protection for primary and secondary of transformer
101B	Circuit breaker protection for secondary of transformer
103	Soft start for reduced voltage starting
105	Forced ventilation (Louvre-Fan-Thermostat)
106	Reversing starter
108	Through the door overload reset buttons
109	Tank alert
112	U/L approval of panel
113	Provision for padlock on enclosure

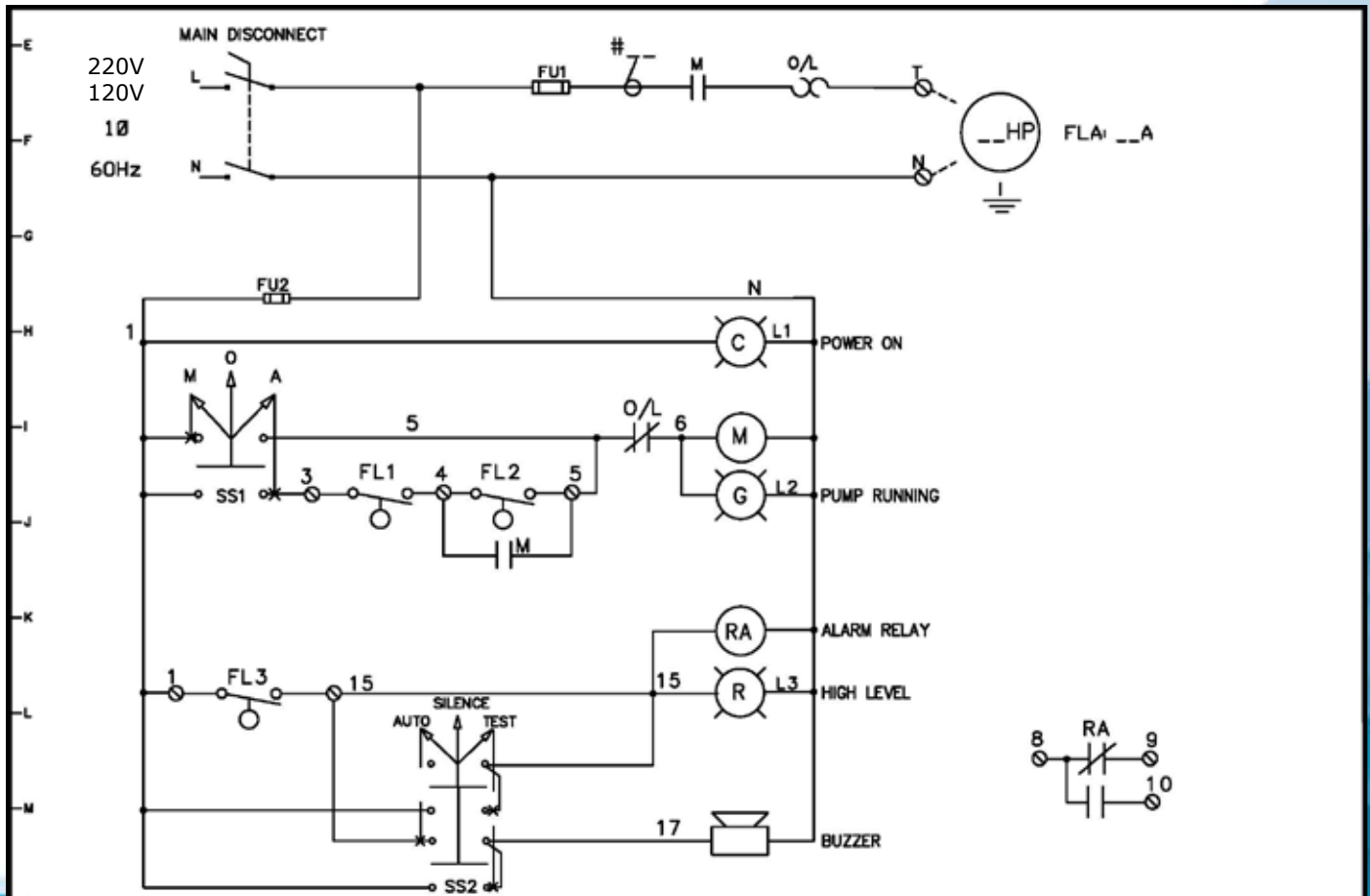

NEMA 1 ENCLOSURE

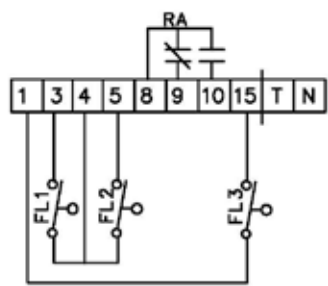
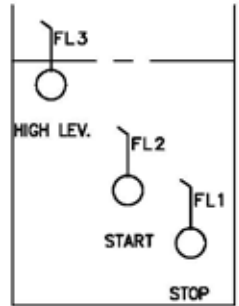
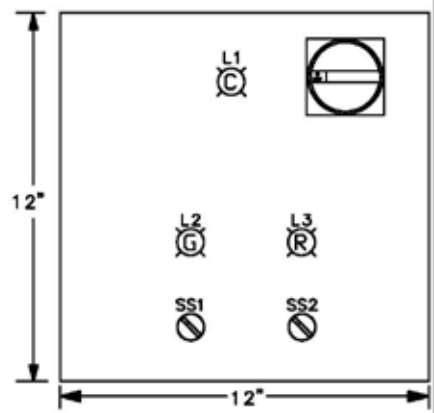

REMARKS: REMARQUES :			TITLE: SIMPLEX		REV.	DESCRIPTION
			PROJECT:			
DRAWN BY: S. DeMONTIGNY		CONTROLLED BY:		DATE: 12-05-2000	DRAWING #: S. D. 8506-A	DPT. #: 00
						PAGE 1 OF 1





# SIMPLEX SUBMERSIBLES

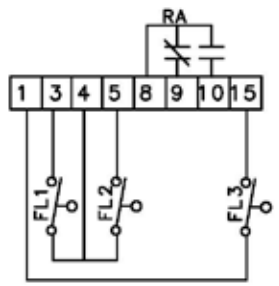
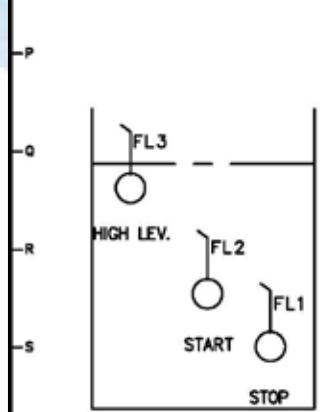
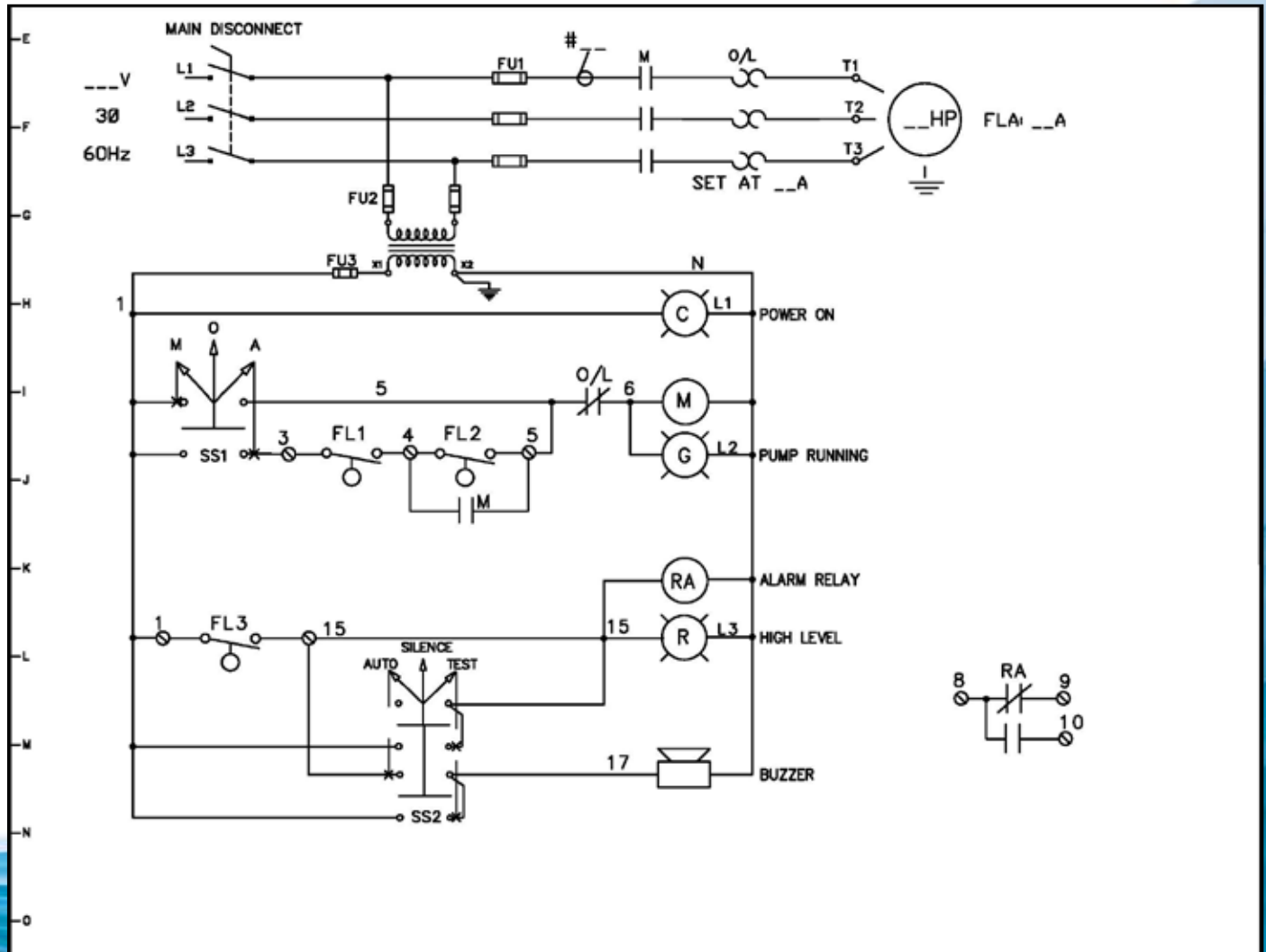

NEMA 1 ENCLOSURE

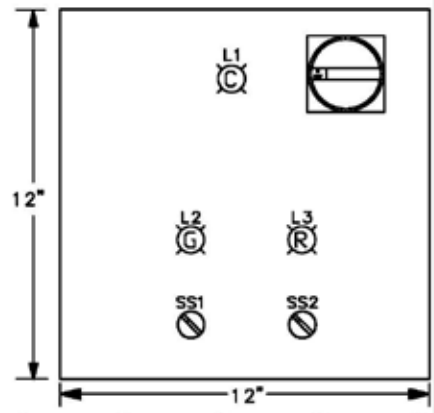

REMARKS: REMARQUES :										REV.		DESCRIPTION	
										TITLE: SIMPLEX		DRAWING #: S. D. 8532-A	
PROJECT:										DPT.:		00	
DRAWN BY: S. DeMONTIGNY		CONTROLLED BY:		DATE: 12-05-2000						PAGE 1 OF 1			



## Standard for Duplex Submersible Panels

A NEMA 1 enclosure, including a main disconnect switch, two sets of HRC fuses for short-circuit protection, two magnetic starters, one transformer with primary and secondary fuses (for system other than 120v), 120v control circuit, alternating circuit, provision to connect four N.O. floats (FL1: stop float, FL2: lead pump start, FL3: lag pump start, FL4: high water level), automatic transfer to lag pump in case of lead pump overload, two "Hand Off Auto" selectors switches, "Power on", "Pump 1 run", "Pump 2 run", "High water level", pilot lights, audible alarm with silencer and test and dry contact for remote alarm.

NEMA Type 1  
General Purpose

To prevent accidental contact with enclosed apparatus. Suitable for application Indoors, where not exposed to unusual service conditions.

NEMA Type 2  
Driptight

To prevent accidental contact with enclosed apparatus. Excludes falling moisture or dirt.

NEMA Type 4  
Watertight

Designed to exclude water applied in form of hose stream. To protect against steam of water during cleaning operations, etc.

NEMA Type 4X  
Corrosion  
Resistant

Designed to exclude water supplied in form of hose stream and used in areas where serious corrosion problem exists.

NEMA Type 12  
Industrial Use

Excludes dust, lint, fibers and flyings or oil or coolant seepage.



## SUBMERSIBLES

# Standard for Duplex Submersible Panels

OPT#	DESCRIPTION
3	Enclosure Eemac/Nema 12 – Dust tight
4	Enclosure Eemac/Nema 4 – Outdoor – Protection against hose directed water
4A	Enclosure Eemac/Nema 4X – Same as Item 4 but fibreglass corrosion proof
4B	Enclosure Eemac/Nema 4X – Same as item 4 but stainless steel painted corrosion proof (brushed finish available)
5	Alarm relay for remote indication
6	Alarm block (buzzer-silence selector-pilot light)
6A	Alarm block – as above but with silence push button
7	Motor overload (over current) indication per pump (pilot light)
7A	As above but with dry contact for remote indication
8	Seal leak fault per pump (conductivity relay with pilot light)
8A	As above but with dry contact for remote indication
9	Motor overheat fault indication per pump (pilot light)
9A	As above but with dry contact for remote indication
10	Pilot light for various function
11	Alarm bell
12	Elapsed time meter (Nema 1) per pump
13	Intrinsic safe relay (use when floats or electrodes are located in explosive medium)
14	Pump control using conductivity relay and electrodes
15	Loss of phase fault indication (pilot light) on incoming power (use with 3 phase supply)
17	Globe alarm (25 watt-non flashing-shatter proof)
18	Pump protection with breaker on single phase system - Max. 40 Amps - (branch circuit protection device rated – Type E rating)
19	Heater element + thermostat
20	Time clock (use for alternating pumps – Specify 12 hours/24 hours/weekly)
21	Main disconnect
21A	Disconnect for each pump controlled by panel
22	Installation of capacitor pack in panel (for starting single phase pumps)
23	Alternating relay (Electro-Mech)
24	Fault indication (Relay + pilot light)
25	Alternating relay - Electronic
26	Alternator - Mechanical
27	Programmable controller
31	Stop/Start with one float
32	Stop/Start with two floats
35	120V Supply for external load (Specify load)
36	Emergency stop push button
38	Low level indication (pilot light)
38A	Low level indication – shutdown with remote indication
39	Low low level indication (pilot light)
39A	Low low level indication – shut down with remote indication
40	Additional stop-start push button per pump
41	Provision for connection of solenoid
43	Remote start/stop signal
43A	24 Volt start signal
44	Lamp test push button
44A	Push to test push button



## Standard for Duplex Submersible Panels

OPT#	DESCRIPTION
47	Off delay timer
48	Two positions selector
55	Indication only of pump failure to start
60	Float failure alarm
62	Lead pump selector switch
63	Ammeter – CT operated – for two pumps
64	Voltmeter for system voltage – Direct read
65	Pump stop indication
67	Fault with latching relay and reset button
68	Remote signal for low of power
69	Current detection relay per pump (to confirm pump running)
70	Loss of phase and phase reversal detection and indication (three phase system)
72	Timer for minimum run
73	Timer for maximum run
74	General alarm indication with relay
75	Lag pump demand indication (pilot light)
77	Lightning arrester
78	Extra for flashing function on pilot light or globe
79	Ground fault indication with pilot light (no stopping of pump)
80	Duplex receptacle – 120 V – 100Watts
81	Motor circuit interruptor (instead of fuses) – Max. 40 Amps – Rated as branch circuit protection device – Type E
81A	Moulded case circuit protector (replaces fuses)
82	Repeat cycle timer
84	Telephone dialler with battery back-up
85	Push button for misc. sequence (describe sequence)
86	Alarm high level
86A	Start lag pump on high level
87	Pump start counter
88	Variable freq. drive for variable speed pumps
89	Line or load reactor for above
91	Stop pump on low level in manual mode
93	Horn
95	Auto reset of latched faults on resumption of power
99	Blown fuse indication for single phase system
100	Incoming power from two sources with one control transformer
100A	Incoming power from two sources with two control transformers
101A	Circuit breaker protection for primary and secondary of transformer
101B	Circuit breaker protection for secondary of transformer
103	Soft start for reduced voltage starting
104	Mini-Cas II for seal and temperature fault on Flyght pumps (one per pump)
105	Forced ventilation (Louvre-Fan-Thermostat)
106	Reversing starter
108	Through the door overload reset buttons
109	Tank alert
112	U/L approval of panel
113	Provision for padlock on enclosure



# DUPLEX SUBMERSIBLE

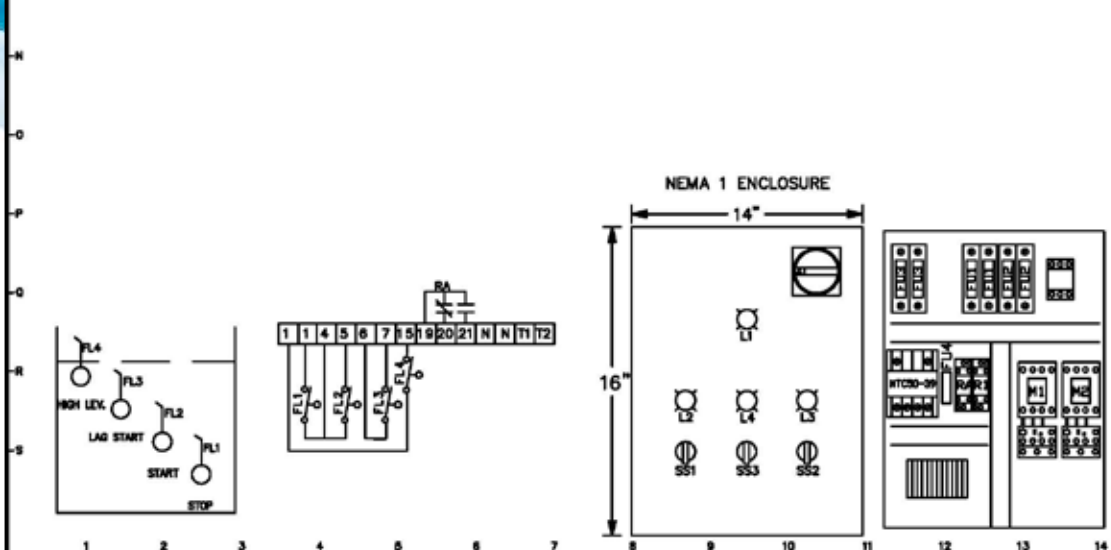
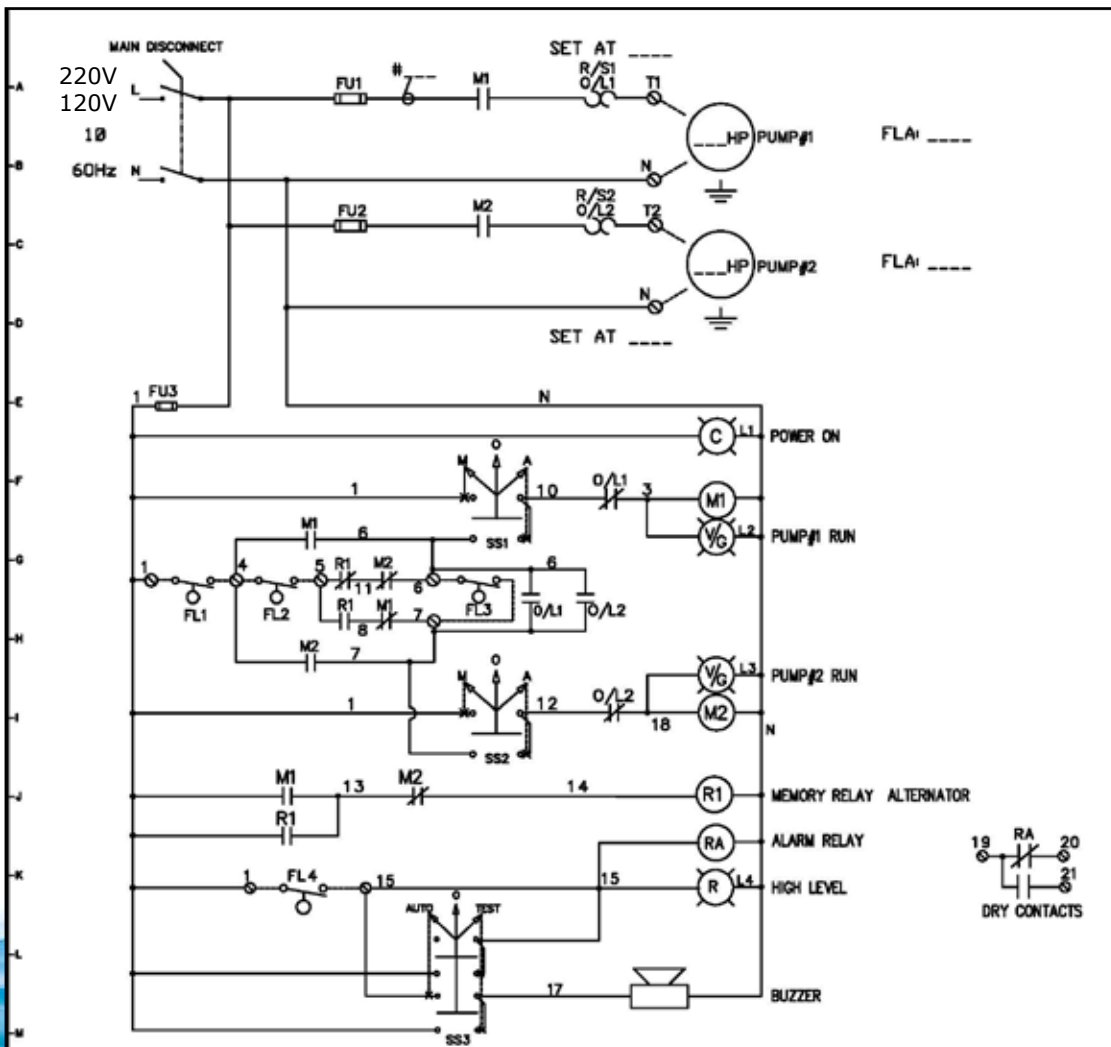

REMARKS: REMARQUES :		CUSTOMER		REV.	DESCRIPTION
		TITLE: DUPLEX			
		PROJECT:		DRAWING #: S. D. 8506-B	
DRAWN BY: S. DeMONTIGNY	CONTROLLED BY:	DATE: 12-05-2000	OPT. # 00		PAGE 1 OF 1



# DUPLEX SUBMERSIBLE

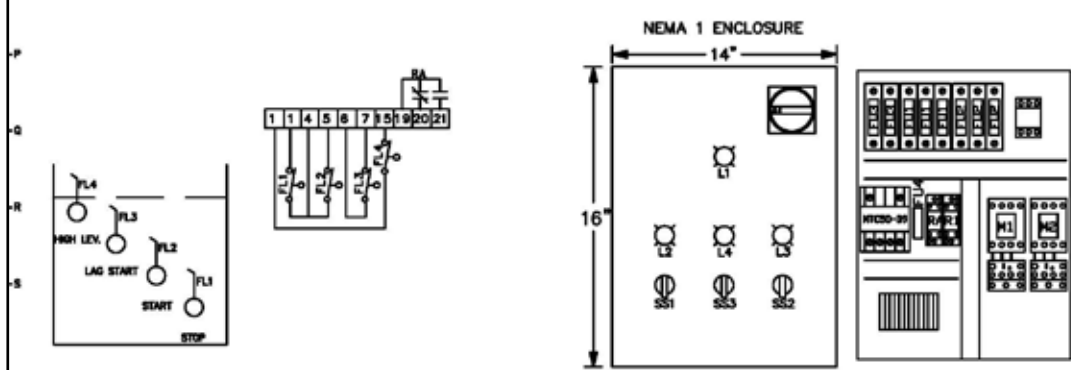
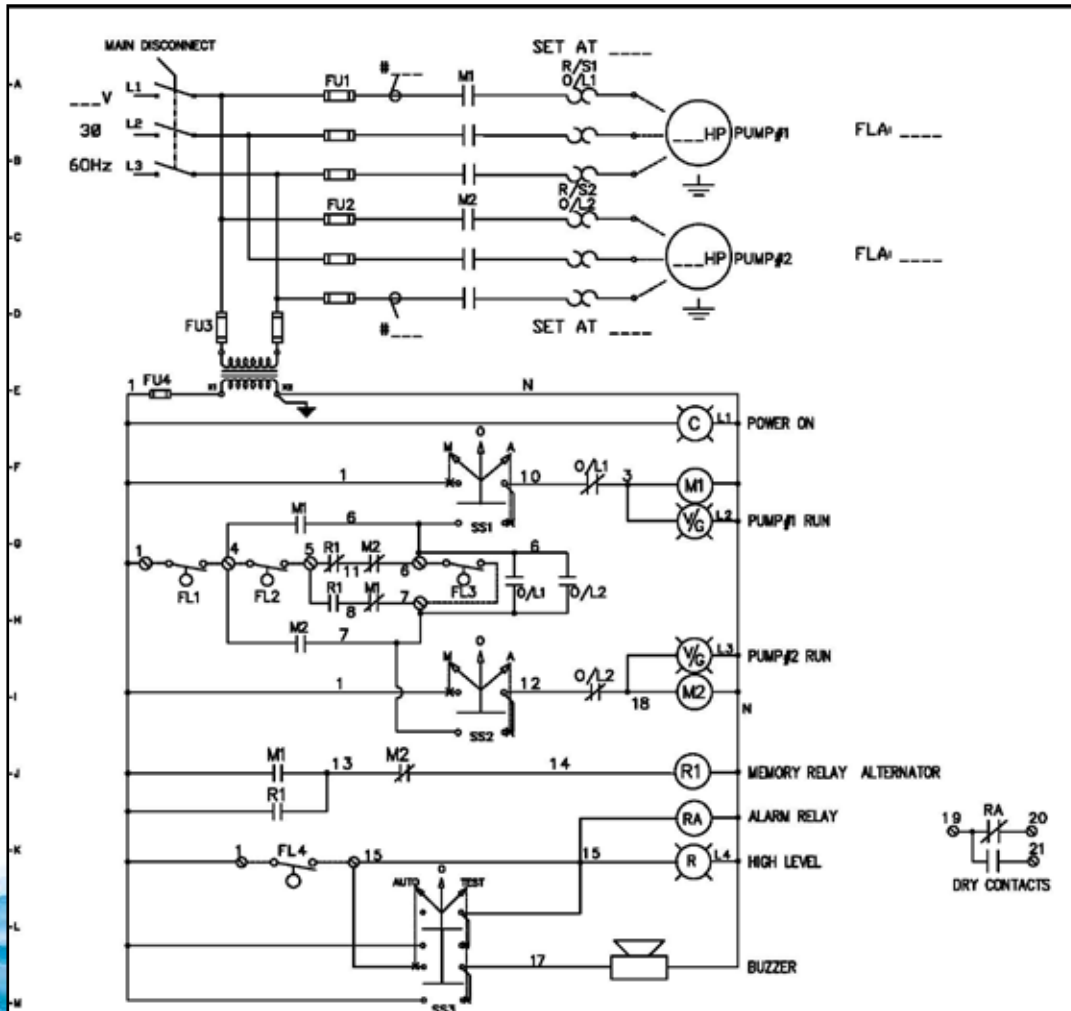

REMARKS: REMARQUES :		CUSTOMER:		REV.	DESCRIPTION
		TITLED DUPLEX			
		PROJECT:		DRAWING #: S. D. 8507-B	OPT.: 00
DRAWN BY: S. DeMONTIGNY	CONTROLLED BY:	DATE: 12-05-2000	PAGE 1 OF 1		

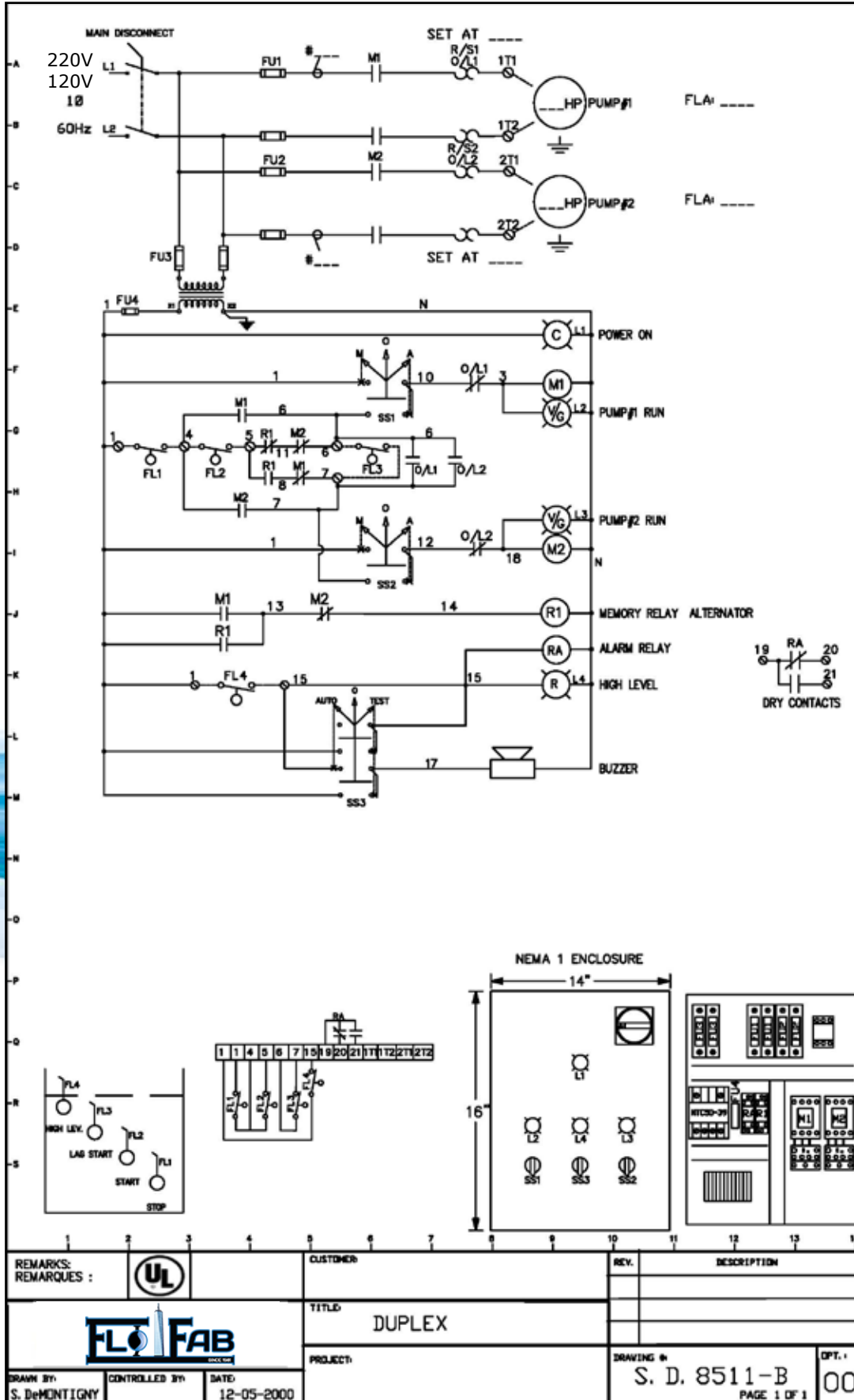

REMARKS: REMARKES :			CUSTOMER	REV.	DESCRIPTION
			TITLE DUPLX		
DRAWN BY: S. DeMONTIGNY	CONTROLLED BY:	DATE: 12-05-2000	PROJECT:	DRAWING #: S. D. 8511-B	OPT. #: 00
				PAGE 1 OF 1	