



Jockey Fire Pump

PSM/PSMCF Series

50HZ



PSM



PSMCF



www.flofab.com

001-cat-2016-psmf50

Go to www.flofab.com in Our Products Section to see the Master Spec - <http://www.arcomnet.com/masterspec/>

TABLE OF CONTENTS

GENERAL DATA

PERFORMANCE SCOPE & PRODUCT RANGE.....	2
PRODUCT INFORMATIONS.....	3
PRODUCT SPECIFICATIONS.....	4
SECTION DRAWING.....	5-8
PERFORMANCE CURVES.....	6
PERFORMANCE TABLE, INSTALLATION SKETCH, SIZE AND WEIGHT.....	7
XRI - GENERAL DATA.....	8

TECHNICAL DATA

PERFORMANCE CURVE.....	9-52
PERFORMANCE DATA.....	9-52
INSTALLATION SKETCH.....	9-52
SIZE AND WEIGHT.....	9-52

HISTORY

Flo Fab was established in 1981 by Denis Gauvreau who created and developed the products line and constantly being perfected by Marc Gauvreau, as well as by a team of professional engineers and designers. It's a combination of existing designs from several renowned products and the innovative ideas of a new generation professionals.

Through the years, Flo Fab has acquired several companies and service entities including : AQUA-PROFAB (ASME Tanks manufacturer), MÉNARD, LÉONARD ÉLECTRIQUE, PMA. , Furthermore Flo Fab purchased equipment, fabrication designs and patterns from IDEALCO, a manufacturer of shell and tube type heat exchangers.

The after sales services, sales, engineering, R&D, production, quality control, accounting and administration departments of all the above companies share the same location.

In December 2014, Marc Gauvreau, son of the founder, acquired all shares of The company. Flo Fab and is constantly investing in new state of the art innovations new product like the XRI series and Prefab Skid for Hydronic Heating & cooling system, pumping systems. This has allowed Flo Fab to retain competent and experienced staff of professionals with varied and specialized abilities that constantly work on improving our existing products and add new engineered solutions that exceeding customer's expectations .

Flo Fab has grown quite rapidly and now proudly offers of a wide range of products available directly from one manufacturer. This includes pumps & pump packages, tanks, heat exchangers & hydronic accessories. This allows each project stakeholders to enjoy economical savings, peace of mind, best value for their investment and optimized total cost of ownership.





Performance Scope & Product Range

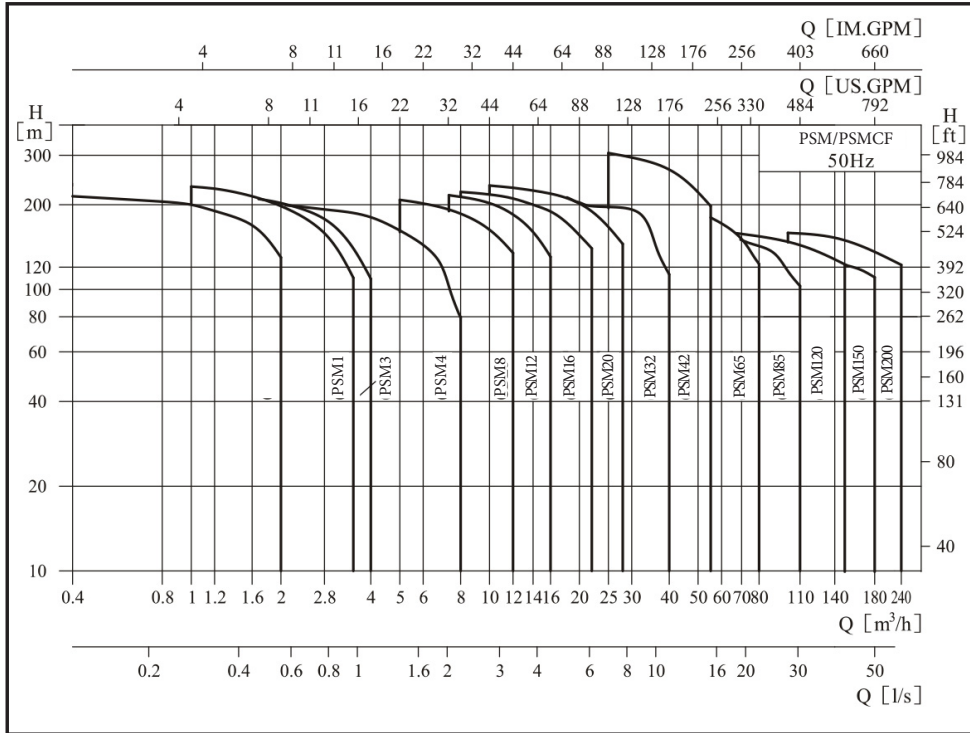

DESCRIPTION	PSM 1	PSM 2	PSM 3	PSM 4	PSM 8	PSM 12	PSM 16	PSM 20	PSM 32	PSM 42	PSM 65	PSM 85	PSM 120	PSM 150	PSM 200
Rated flow(m³/h)	1	2	3	4	8	12	16	20	32	42	65	85	120	150	200
Rated flow (GPM)	4.4	8.8	13.2	17.6	35.2	52.8	70.4	88	140.9	184.9	286.2	374.2	528.3	660.4	880.6
Rated flow (l/s)	0.28	0.56	0.83	1.1	2.2	3.3	4.4	5.6	8.9	11.7	18	24	33	41.6	55.6
Flow Range (m³/h)	0.4-2	1-3.5	1.2-4	1.5-7	5-12	7-16	8-22	10-28	16-40	25-55	30-80	50-110	60-150	80-180	100-240
Flow Range (GPM)	1.8-8.8	4.4-15.41	5.3-17.6	6.6-30.8	22-52.8	30.8-70.4	35.2-96.9	44-123.3	70.4-176.1	110-242.2	132.1-352.2	220.1-484.3	264.2-660.4	352.2-792.5	440.2-1056.7
Flow Range (l/s)	0.11-0.56	0.28-0.97	0.33-1.1	0.42-1.9	1.4-3.3	1.9-4.4	2.2-6.1	2.8-7.8	4.4-11.1	6.9-15.3	8.3-22.2	13.8-30.5	16.7-41.7	22-50	27.8-66.7
Max Pressure (Bar)	21	23	22	21	21	22	22	23	26	30	22	17	16	16	16
Motor Power (kW)	0.37-2.2	0.37-3	0.37-3	0.37-4	0.75-7.5	1.5-11	2.2-15	1.1-18.5	1.5-30	3.0-45	4.0-45	5.5-45	11-75	11-75	18.5-110
Temperature range (C°)	-15~+120														
Max Efficiency (%)	44	46	54	57	62	63	66	69	73	75	76	77	74	73	79
PSM	•	•	•	•	•	•	•	•	•	•	•	•	•	•	•
PSMCF	•	•	•	•	•	•	•	•	•	•	•	•	•	•	•
PSM Pipe Connection															
DIN Flange	DN25	DN25	DN25	DN32	DN40	DN50	DN50	DN50	DN65	DN80	DN100	DN100	DN125	DN125	DN150
Oval Flange	G1	G1	G1	G1 1/4	G1 1/2										
PSMCF Pipe Connection															
DIN Flange	DN25	DN25	DN25	DN32	DN40	DN50	DN50	DN50	DN65	DN80	DN100	DN100	DN125	DN125	DN150
Cutting Ferule Joint	•	•	•	•	•	•	•	•							
Pipe Thread	•	•	•	•	•	•	•	•							



● Product Informations

● Pump

PSM/PSMCF is a kind of vertical non-self priming multistage centrifugal pump, which is driven by a standard electric motor. The motor output shaft directly connects with the pump shaft through a coupling. The pressure-resistant cylinder and flow passage components are fixed between pump head and inlet & outlet section with stay bolts. The inlet and outlet are located at the pump bottom at the same plane. This kind of pump can be equipped with an intelligent protector to effectively prevent it from dry-running, out-of-phase and overload.

● Motor

- Full-enclosed air-blast two-pole standard motor
- Protection class: IP55
- Insulation class: F
- Standard voltage: 50Hz: 1 × 220-230 / 240V
3 × 200-220 / 346-380V
3 × 220-240 / 380-415V
3 × 380-415V

● Definition of Model

PSM/PSMCF 1,2,3,4,8,12,16 and 20

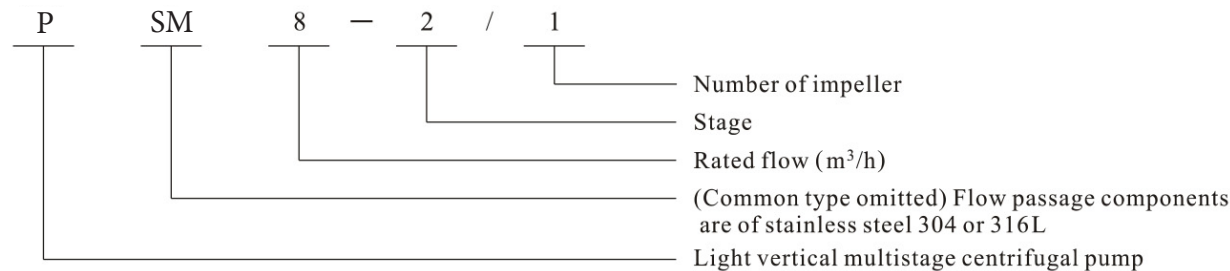

PSM/PSMCF 32,42,65,85,120 and 150

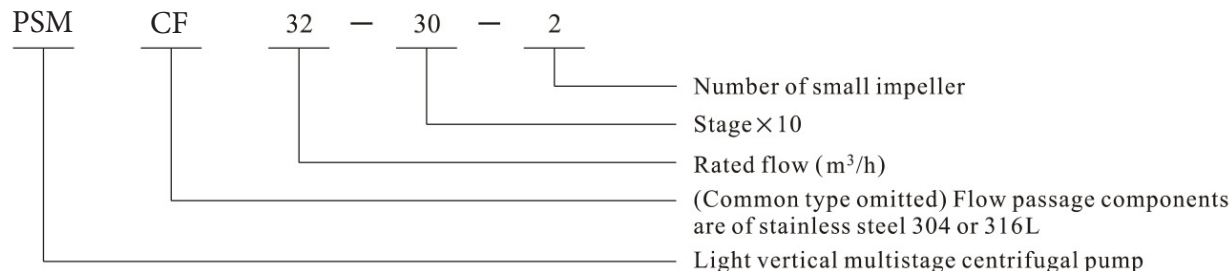

● Application

PSM/PSMCF is a kind of multifunctional products. It can be used to convey various medium from tap water to industrial liquid at different temperature and with different flow rate and pressure. PSM type is applicable to conveying non-corrosive liquid, while PSMCF is suitable for slightly corrosive liquid.

- Water supply: Water filter and transport in Waterworks, boosting of main pipeline, boosting in high-rise buildings.
- Industrial boosting: Process flow water system, cleaning system, high-pressure washing system, fire fighting system.
- Industrial liquid conveying: Cooling and air-conditioning system, boiler water supply and condensing system, machine-associated purpose, acids and alkali.
- Water treatment: Ultrafiltration system, reverse osmosis system, distillation system, separator, swimming pool.
- Irrigation: Farmland irrigation, spray irrigation, dripping irrigation.

● Operation conditions

- Thin, clean, non-flammable and non-explosive liquid containing no solid granules and fibers.
- Liquid temperature:
Normal temperature type: -15°C ~ +70°C,
Hot water type: -15°C ~ +120°C
- Ambient temperature: up to +40°C
- Altitude: up to 1000m

● Product Specifications

PSM/PSMCF

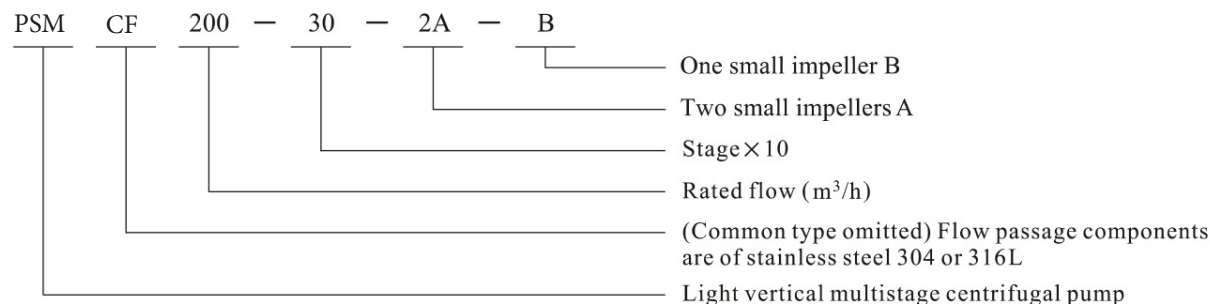

● Max. Working pressure

Model	Curve number
PSM1,2,3,4 Flange	2
PSM1,2,3,4 Oval Flange	1
PSMCF1,2,3,4	2
PSM8,12,16,20 Flange	3
PSM8 Oval Flange	1
PSMCF8,12,16,20	3
PSM, PSMCF 32	
32-10-1~32-70	1
32-80-2~32-120	4
32-130~32-140	5
PSM, PSMCF 42	
42-10-1~42-60	1
42-70-2~42-90	4
42-100-2~42-130-2	5
PSM, PSMCF 65	
65-10-1~65-50	1
65-60-2~65-80-1	4
PSM, PSMCF 85	
85-10-1~85-50-2	1
85-50~85-60	4
PSM, PSMCF 120,150,200	6

The following figure shows the limitation of pressure and temperature, which shall be in the scope as shown in the figure.

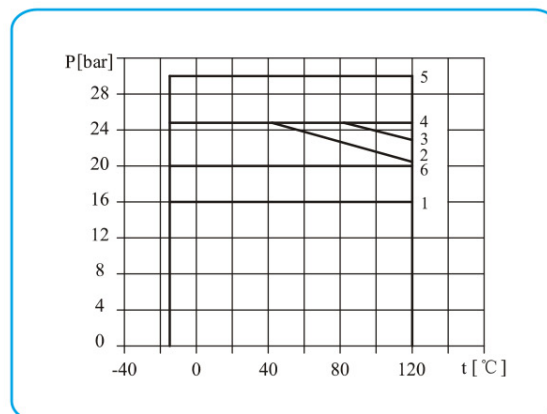

● Max. Ambient temperature

When the pump operates under ambient temperature higher than 40°C or under altitude higher than 1000m, because of low air density and poor cooling effects, the motor output power P₂ will be decreased to certain extent. If the pump is operated under the above-said conditions, it should be equipped with motor of higher power.

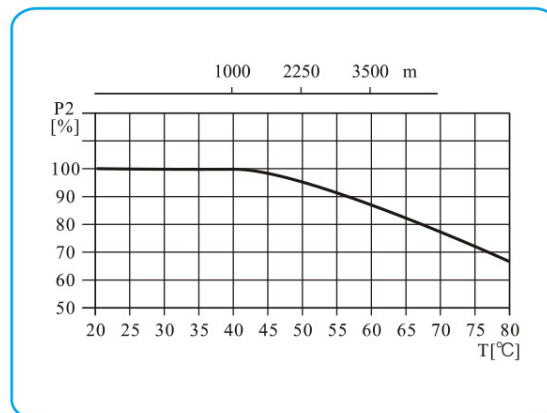

● **Section drawing PSM/PSMCF 1,2,3,4**

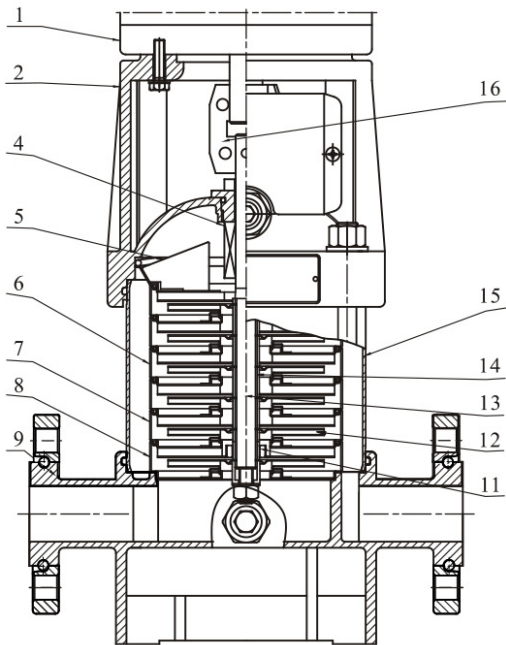

PSM

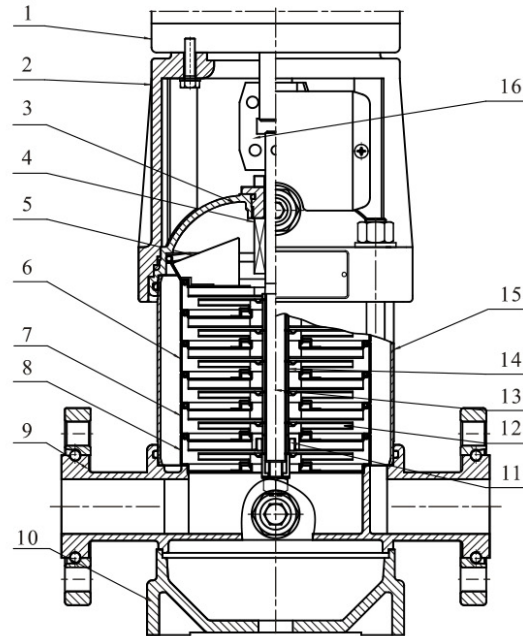

PSMCF

● **Material PSM/PSMCF 1,2,3,4**

NO.	Name	Material	AISI/ASTM
1	Motor		
2	Pump head	Cast iron	ASTM25B
4	Mechanical seal		
5	Top diffuser	Stainless steel	AISI304
6	Diffuser	Stainless steel	AISI304
7	Support diffuser	Stainless steel	AISI304
8	Inducer	Stainless steel	AISI304
11	Bearing	Tungsten carbide	
12	Impeller	Stainless steel	AISI304
13	Shaft	Stainless steel	AISI304 AISI316L

NO.	Name	Material	AISI/ASTM
14	Impeller sleeve	Stainless steel	AISI304
15	Cylinder	Stainless steel	AISI304
16	Coupling	Carbon steel	

PSMCF

3	Seal base	Stainless steel	AISI304
9	Inlet and outlet chamber	Stainless steel	AISI304
10	Base plate	Cast iron	ASTM25B

PSM

9	Inlet and outlet chamber	Cast iron	ASTM25B
---	--------------------------	-----------	---------

● **Section drawing PSM/PSMCF8,12,16,20**

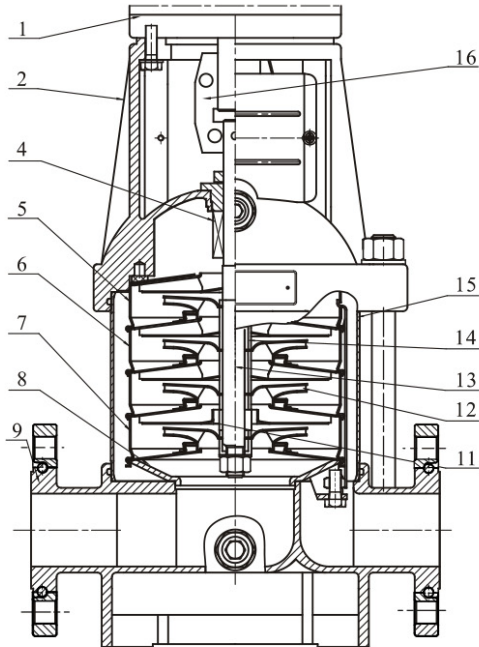

PSM

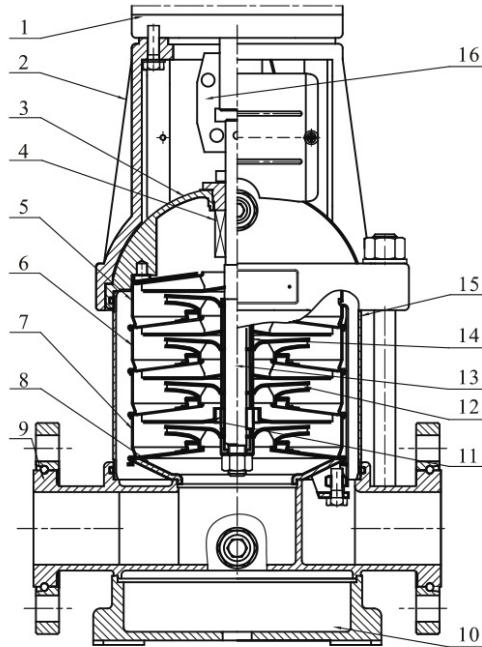

PSMCF

● **Material PSM/PSMCF 8,12,16,20**

NO.	Name	Material	AISI/ASTM
1	Motor		
2	Pump head	Cast iron	ASTM25B
4	Mechanical seal		
5	Top diffuser	Stainless steel	AISI304
6	Diffuser	Stainless steel	AISI304
7	Support diffuser	Stainless steel	AISI304
8	Inducer	Stainless steel	AISI304
11	Bearing	Tungsten carbide	
12	Impeller	Stainless steel	AISI304
13	Shaft	Stainless steel	AISI304 AISI316L

NO.	Name	Material	AISI/ASTM
14	Impeller sleeve	Stainless steel	AISI304
15	Cylinder	Stainless steel	AISI304
16	Coupling	Carbon steel	
PSMCF			
3	Seal base	Stainless steel	AISI304
9	Inlet and outlet chamber	Stainless steel	AISI304
10	Base plate	Cast iron	ASTM25B
PSM			
9	Inlet and outlet chamber	Cast iron	ASTM25B

● **Section drawing PSM/PSMCF120,150,200**

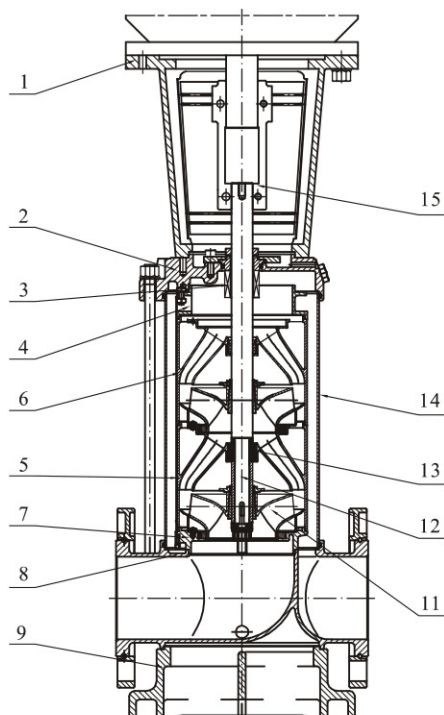

● **Material PSM/PSMCF 120,150,200**

NO.	Name	Material	AISI/ASTM
1	Bracket	Cast iron	ASTM25B
3	Mechanical seal		
4	Discharge	Stainless steel	AISI304
5	Support diffuser	Stainless steel	AISI304
6	Diffuser	Stainless steel	AISI304
7	Inducer	Stainless steel	AISI304
9	Base plate	Cast iron	ASTM 80-55-06
11	Impeller	Stainless steel	AISI304
12	Shaft	Stainless steel	AISI304

NO.	Name	Material	AISI/ASTM
13	Bearing	Tungsten carbide	
14	Cylinder	Stainless steel	AISI304
15	Coupling	Carbon steel	
	Rubber parts	NBR	
PSM			
2	Pump head	Cast iron	ASTM 80-55-06
8	Inlet and outlet chamber	Cast iron	ASTM 80-55-06
PSMCF			
2	Pump head	Stainless steel	AISI304
8	Inlet and outlet chamber	Stainless steel	AISI304

● **Section drawing PSM/PSMCF 32,42,65,85**

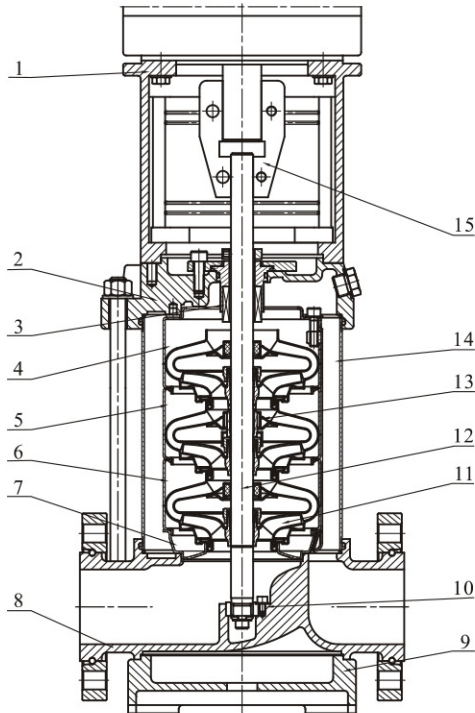

● **Material PSM/PSMCF 32,42,65,85**

NO.	Name	Material	AISI/ASTM
1	Bracket	Cast iron	ASTM25B
3	Mechanical seal		
4	Top diffuser	Stainless steel	AISI304
5	Support diffuser	Stainless steel	AISI304
6	Diffuser	Stainless steel	AISI304
7	Inducer	Stainless steel	AISI304
9	Base plate	Cast iron	ASTM25B
10	Bottom bearing	Tungsten carbide	
11	Impeller	Stainless steel	AISI304

NO.	Name	Material	AISI/ASTM
12	Shaft	Stainless steel	AISI316L AISI304 AISI431
13	Intermediate bearing	Tungsten carbide	
14	Cylinder	Stainless steel	AISI304
15	Coupling	Carbon steel	
	Rubber parts	NBR	
PSM			
2	Pump head	Cast iron	ASTM25B
8	Inlet and outlet chamber	Cast iron	ASTM25B
PSMCF			
2	Pump head	Stainless steel	AISI304
8	Inlet and outlet chamber	Stainless steel	AISI304

Performance curve ISO9906 Annex A 2900rpm

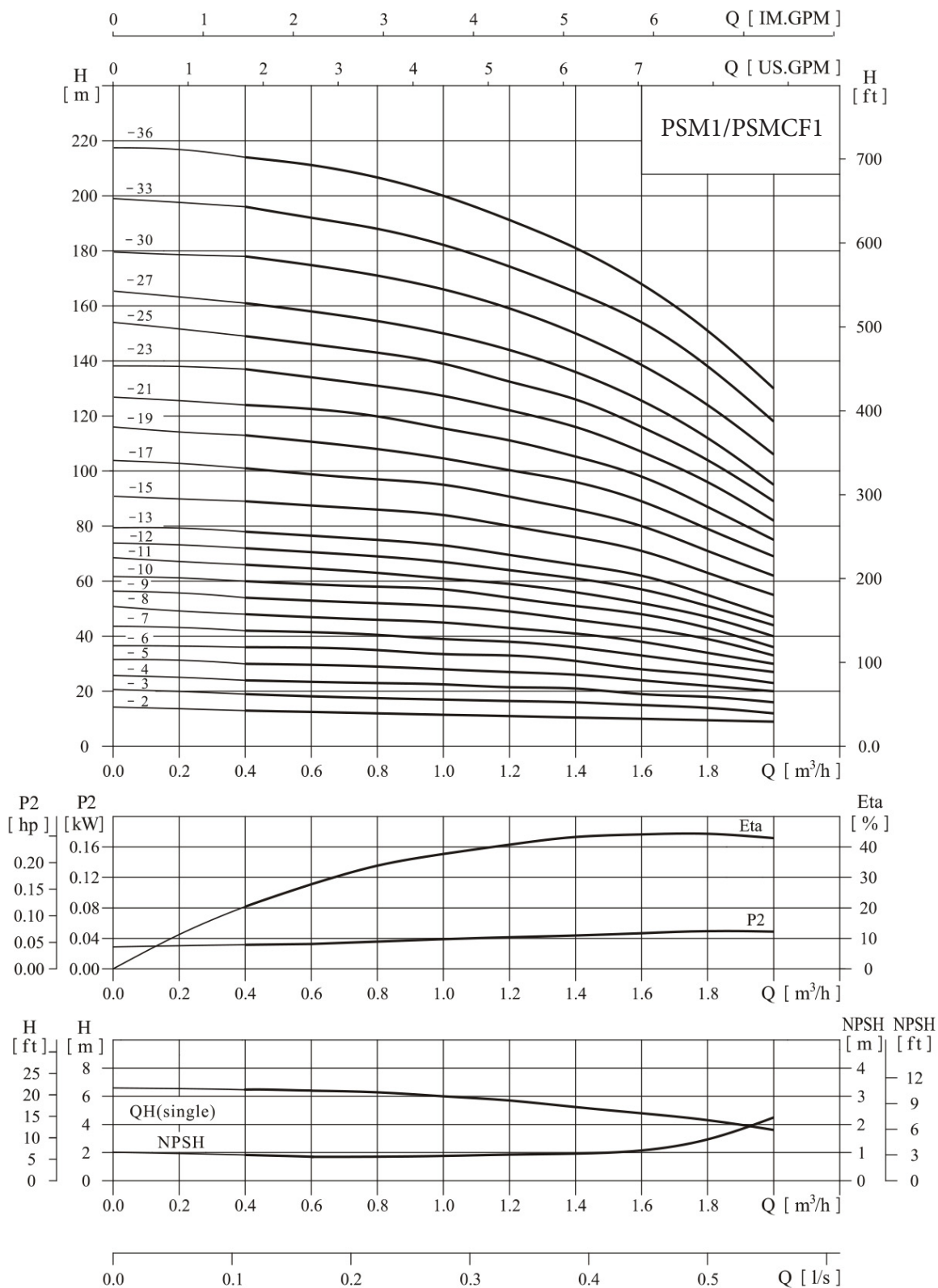

● Performance table

Model	Driving motor		Q (m ³ /h)	0.4	0.6	0.8	1.0	1.2	1.4	1.6	1.8	2.0
	(kW)	(hp)										
P S M 1	2	0.37	0.5	13	12.5	12	11.5	11	10.5	10	9.5	9
	3	0.37	0.5	19	18	17.5	17	16.5	16	15	14	12
	4	0.37	0.5	24	23.5	23	22.5	21.5	21	19	18	16
	5	0.37	0.5	30	29.6	29	28	27	26	24	22	20
	6	0.37	0.5	36	35.5	35	33.5	33	31	28	26	23
	7	0.37	0.5	42	41	40.5	39	38	36	33	30	27
	8	0.55	0.75	48	47	46	45	43	41	38	34	30
	9	0.55	0.75	54	53	52	51	49	46	43	39	33
	10	0.55	0.75	60	59	58	57	54	51	48	43	36
	11	0.55	0.75	66	65	63	61	59	56	52	47	40
	12	0.75	1	72	71	69	67	64	61	57	51	44
	13	0.75	1	78	77	75	73	69	66	62	55	47
	15	0.75	1	89	88	86	84	79	76	71	63	55
	17	1.1	1.5	101	99	97	95	89	86	80	71	62
	19	1.1	1.5	113	110	108	106	99	96	89	79	69
	21	1.1	1.5	124	122	120	117	110	106	98	87	75
	23	1.1	1.5	137	133	131	128	121	116	107	96	82
	25	1.5	2	149	145	143	139	131	126	116	104	89
27	1.5	2	161	157	155	150	141	136	125	112	95	
30	1.5	2	178	175	171	166	157	150	139	124	106	
33	2.2	3	196	192	188	183	173	165	154	137	118	
36	2.2	3	214	210	205	200	190	181	169	151	130	

PSM 1 MODEL	Size (mm)					Size (in)					Weight (kg/lbs)
	B1	B2	B1+B2	D1	D2	B1	B2	B1+B2	D1	D2	
2	258	210	468	148	117	10.16	8.27	18.43	5.83	4.60	20/44.09
3	276	210	486	148	117	10.87	8.27	19.13	5.83	4.60	20/44.09
4	294	210	504	148	117	11.57	8.27	19.84	5.83	4.60	21/46.30
5	312	210	522	148	117	12.28	8.27	20.55	5.83	4.60	21/46.30
6	330	210	540	148	117	12.99	8.27	21.26	5.83	4.60	22/48.50
7	348	210	558	148	117	13.70	8.27	21.97	5.83	4.60	23/50.71
8	366	210	576	148	117	14.40	8.27	22.68	5.83	4.60	24/52.91
9	384	210	594	148	117	15.12	8.27	23.39	5.83	4.60	25/55.11
10	402	210	612	148	117	15.83	8.27	24.09	5.83	4.60	26/57.32
11	420	210	630	148	117	16.54	8.27	24.80	5.83	4.60	26/57.32
12	448	245	693	170	142	17.64	9.65	27.28	6.69	5.59	29/63.93
13	466	245	711	170	142	18.35	9.65	27.99	6.69	5.59	30/66.14
15	502	245	747	170	142	19.76	9.65	29.41	6.69	5.59	31/68.34
17	538	245	783	170	142	21.18	9.65	30.83	6.69	5.59	33/72.75
19	574	245	819	170	142	22.60	9.65	32.24	6.69	5.59	34/74.96
21	610	245	855	170	142	24.02	9.65	33.66	6.69	5.59	35/77.16
23	646	245	891	170	142	25.43	9.65	35.07	6.69	5.59	36/79.36
25	692	290	982	190	155	27.24	11.42	38.66	7.48	6.10	42/92.59
27	728	290	1018	190	155	28.66	11.42	40.07	7.48	6.10	43/94.79
30	782	290	1072	190	155	30.79	11.42	42.20	7.48	6.10	45/99.21
33	836	290	1126	190	155	32.91	11.42	44.33	7.48	6.10	49/108.02
36	890	290	1180	190	155	35.04	11.42	46.46	7.48	6.10	51/112.43

Installation sketch

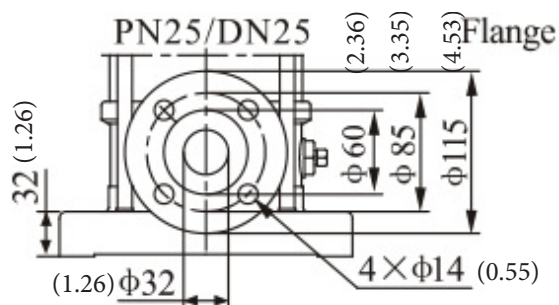
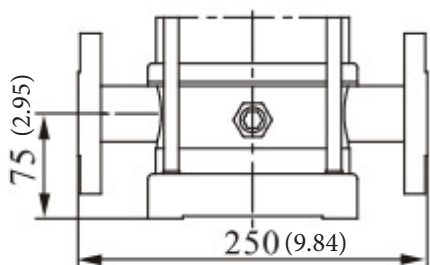
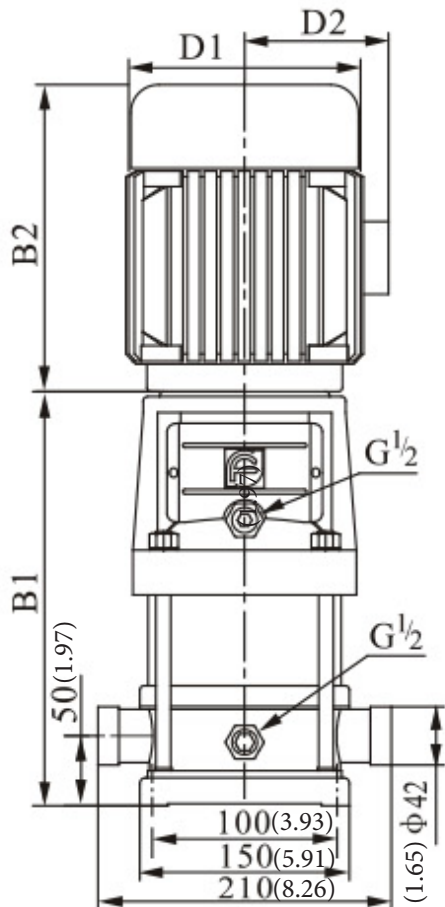



● Performance curve

ISO9906 Annex A 2900rpm

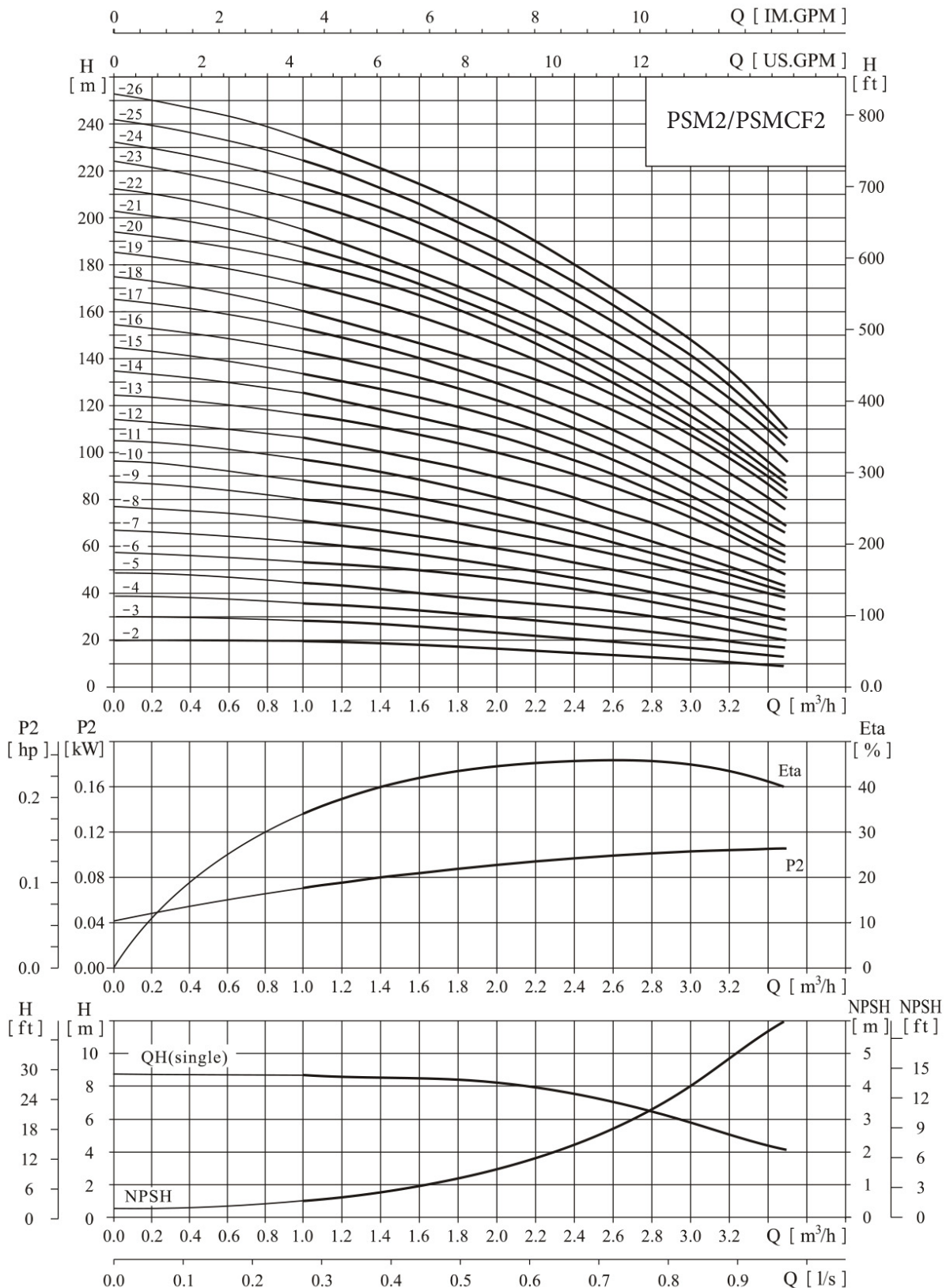

● Performance table

Model	Driving motor		Q (m ³ /h)	1	1.2	1.6	2.0	2.4	2.8	3.2	3.5	
	(kW)	(hp)										
P S M 2	2	0.37	H (m)	18	17	16	15	13	12	10	8	
	3	0.37		27	26	24	22	20	18	15	12	
	4	0.55		36	35	33	30	26	24	20	16	
	5	0.55		45	43	40	37	33	30	24	20	
	6	0.75		1	53	52	50	45	40	36	30	24
	7	0.75		1	63	61	57	52	47	41	35	28
	9	1.1		1.5	80	78	73	67	61	54	45	37
	11	1.1		1.5	98	95	89	82	73	64	54	44
	13	1.5		2	116	114	106	98	89	78	65	52
	15	1.5		2	134	130	123	112	100	90	73	60
	18	2.2		3	161	157	148	136	121	108	91	76
	22	2.2		3	197	192	180	165	148	130	110	90
	26	3.0		4	232	228	214	198	179	158	130	110

PSM 2 MODEL	Size (mm)					Size (in)					Weight (kg/lbs)
	B1	B2	B1+B2	D1	D2	B1	B2	B1+B2	D1	D2	
2	258	210	468	148	117	10.16	8.27	18.43	5.83	4.60	20/44.09
3	276	210	486	148	117	10.87	8.27	19.13	5.83	4.60	20/44.09
4	294	210	504	148	117	11.57	8.27	19.84	5.83	4.60	22/48.50
5	312	210	522	148	117	12.28	8.27	20.55	5.83	4.60	23/50.71
6	340	245	585	170	142	13.39	9.65	23.03	6.69	5.59	26/57.32
7	358	245	603	170	142	14.09	9.65	23.74	6.69	5.59	26/57.32
9	394	245	639	170	142	15.51	9.65	25.16	6.69	5.59	28/61.72
11	430	245	675	170	142	16.92	9.65	26.57	6.69	5.59	29/63.93
13	476	290	766	190	155	18.74	11.42	30.16	7.48	6.10	35/77.16
15	512	290	802	190	155	20.16	11.42	31.57	7.48	6.10	36/79.36
18	566	290	856	190	155	22.28	11.42	33.70	7.48	6.10	41/90.39
22	638	290	928	190	155	25.12	11.42	36.54	7.48	6.10	42/92.59
26	720	315	1035	197	165	28.35	12.40	40.75	7.76	6.50	52/114.64

Installation sketch

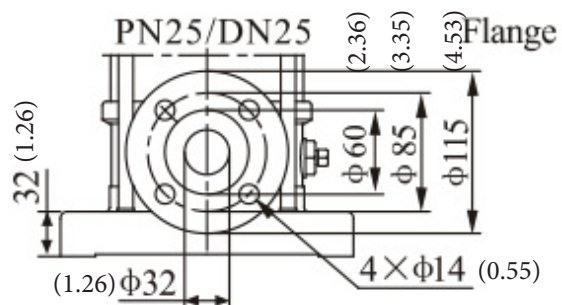
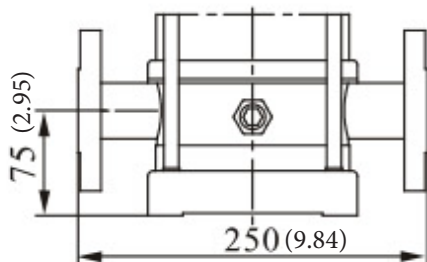
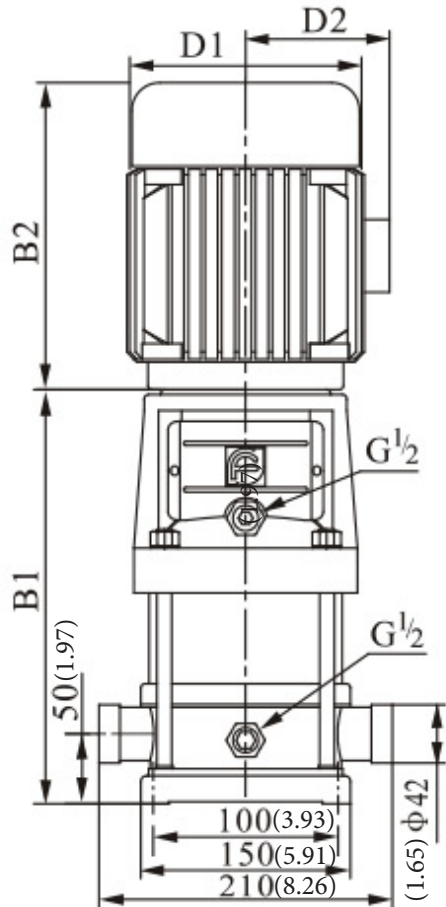

● Performance curve ISO9906 Annex A 2900rpm

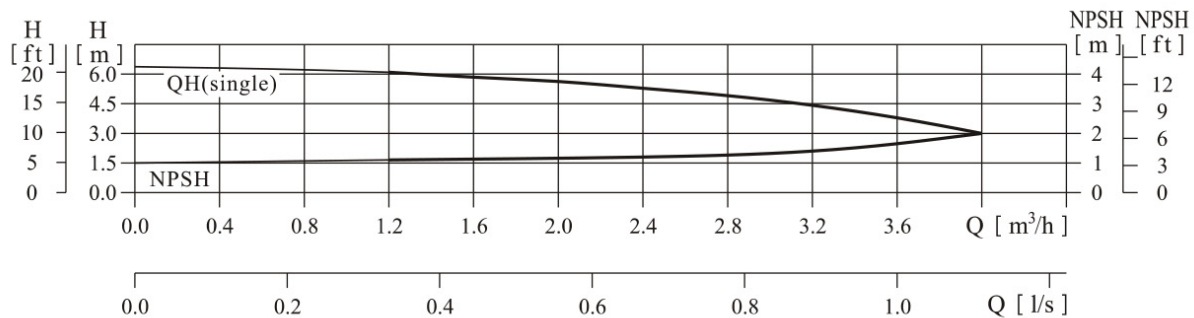
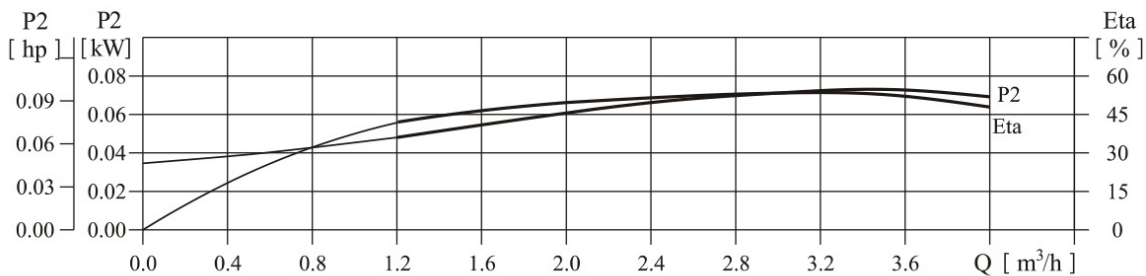
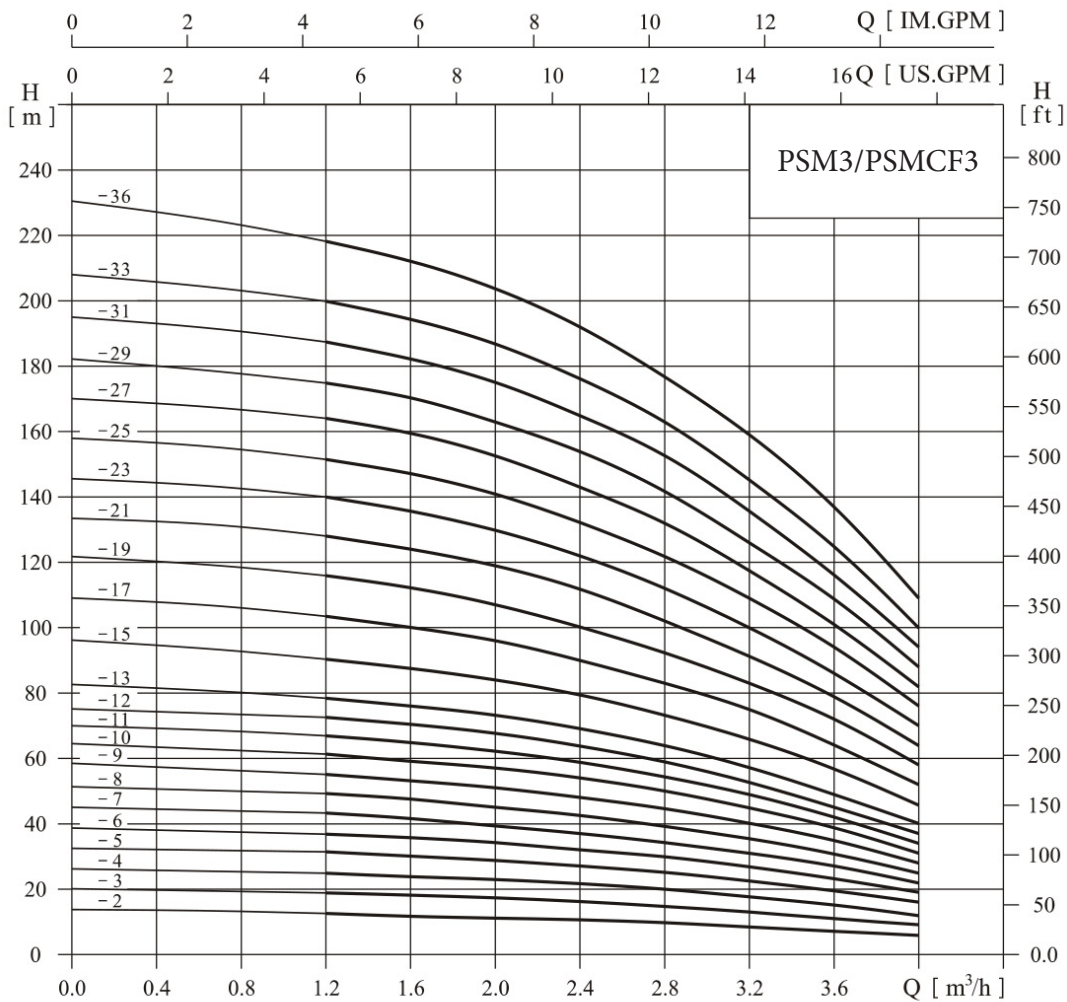

● Performance table

Model	Driving motor		Q (m ³ /h)	1.2	1.6	2.0	2.4	2.8	3.0	3.2	3.6	4.0
	(kW)	(hp)										
2	0.37	0.5	H (m)	12.5	11.5	11	10.5	10	9	8	7	6
3	0.37	0.5		19	18.5	17.5	16.5	15	14	13	11	9
4	0.37	0.5		25	24	23	21.5	20	19	18	15	12
5	0.37	0.5		31	30	29	27	25	23	22	19	16
6	0.55	0.75		36	35	34	32	30	28	27	23	19
7	0.55	0.75		43	41	39	37	34	32	31	27	22
8	0.75	1		49	47	45	43	39	37	35	31	25
9	0.75	1		55	53	51	48	45	42	40	35	28
10	0.75	1		61	59	57	54	50	47	45	39	31
11	1.1	1.5		67	64	61	58	54	51	49	42	34
12	1.1	1.5		73	70	67	63	58	55	52	45	37
13	1.1	1.5		78	76	73	69	64	60	57	49	40
15	1.1	1.5		90	88	84	79	73	69	66	57	46
17	1.5	2		103	100	96	90	83	79	75	64	52
19	1.5	2		115	112	107	100	92	88	83	72	58
21	2.2	3		128	124	119	112	102	98	91	79	64
23	2.2	3		140	135	130	122	112	107	100	86	70
25	2.2	3		151	147	141	131	122	116	109	94	76
27	2.2	3		164	159	152	143	132	124	117	101	82
29	2.2	3		175	170	163	153	142	133	126	109	88
31	3.0	4		187	182	175	165	153	142	135	116	94
33	3.0	4		199	194	187	176	163	151	145	125	100
36	3.0	4		218	212	204	192	178	168	159	137	109

PSM 3 MODEL	Size (mm)					Size (in)					Weight (kg/lbs)
	B1	B2	B1+B2	D1	D2	B1	B2	B1+B2	D1	D2	
2	258	210	468	148	117	10.16	8.27	18.43	5.83	4.60	20/44.09
3	276	210	486	148	117	10.87	8.27	19.13	5.83	4.60	20/44.09
4	294	210	504	148	117	11.57	8.27	19.84	5.83	4.60	21/46.30
5	312	210	522	148	117	12.28	8.27	20.55	5.83	4.60	21/46.30
6	330	210	540	148	117	12.99	8.27	21.26	5.83	4.60	23/50.71
7	348	210	558	148	117	13.70	8.27	21.97	5.83	4.60	24/52.91
8	376	245	621	170	142	14.80	9.65	24.45	6.69	5.59	27/59.52
9	394	245	639	170	142	15.51	9.65	25.16	6.69	5.59	28/61.72
10	412	245	657	170	142	16.22	9.65	25.87	6.69	5.59	28/61.72
11	430	245	675	170	142	16.93	9.65	26.57	6.69	5.59	29/63.93
12	448	245	693	170	142	17.64	9.65	27.28	6.69	5.59	30/66.14
13	466	245	711	170	142	18.35	9.65	27.99	6.69	5.59	31/68.34
15	502	245	747	170	142	19.76	9.65	29.41	6.69	5.59	32/70.55
17	548	290	838	190	155	21.57	11.42	32.99	7.48	6.10	38/83.77
19	584	290	874	190	155	22.99	11.42	34.40	7.48	6.10	39/85.98
21	620	290	910	190	155	24.40	11.42	35.83	7.48	6.10	42/92.59
23	656	290	946	190	155	25.83	11.42	37.24	7.48	6.10	43/94.80
25	692	290	982	190	155	27.24	11.42	38.66	7.48	6.10	44/97
27	728	290	1018	190	155	28.66	11.42	40.07	7.48	6.10	45/99.21
29	764	290	1054	197	165	30.07	11.42	41.50	7.76	6.50	46/101.41
31	810	315	1125	197	165	31.88	12.40	44.29	7.76	6.50	54/119.05
33	846	315	1161	197	165	33.31	12.40	45.70	7.76	6.50	55/121.25
36	900	315	1215	197	165	35.43	12.40	47.83	7.76	6.50	57/125.66

Installation sketch

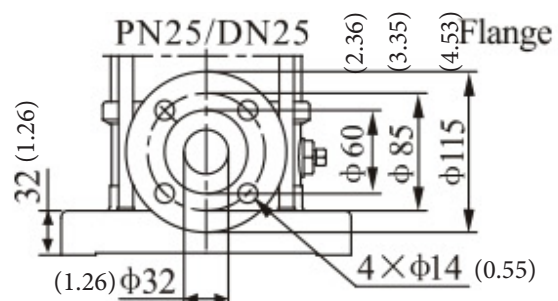
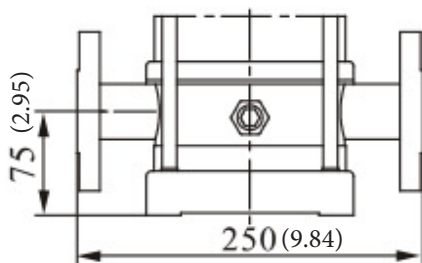
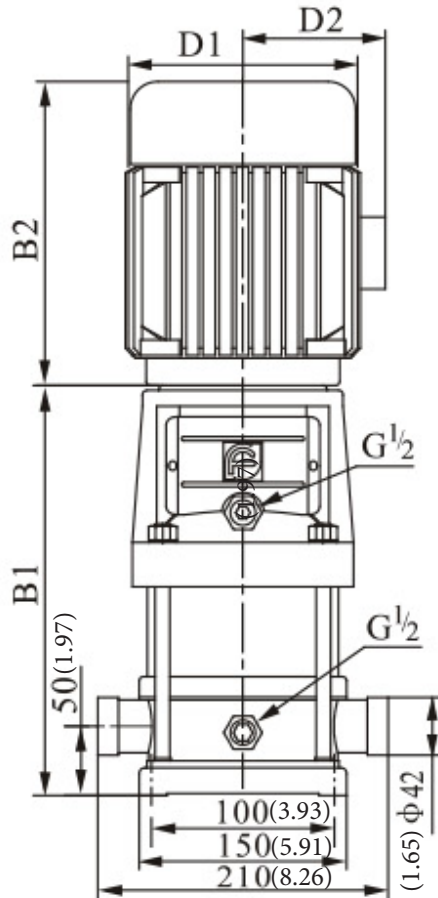



● Performance curve **ISO9906 Annex A 2900rpm**

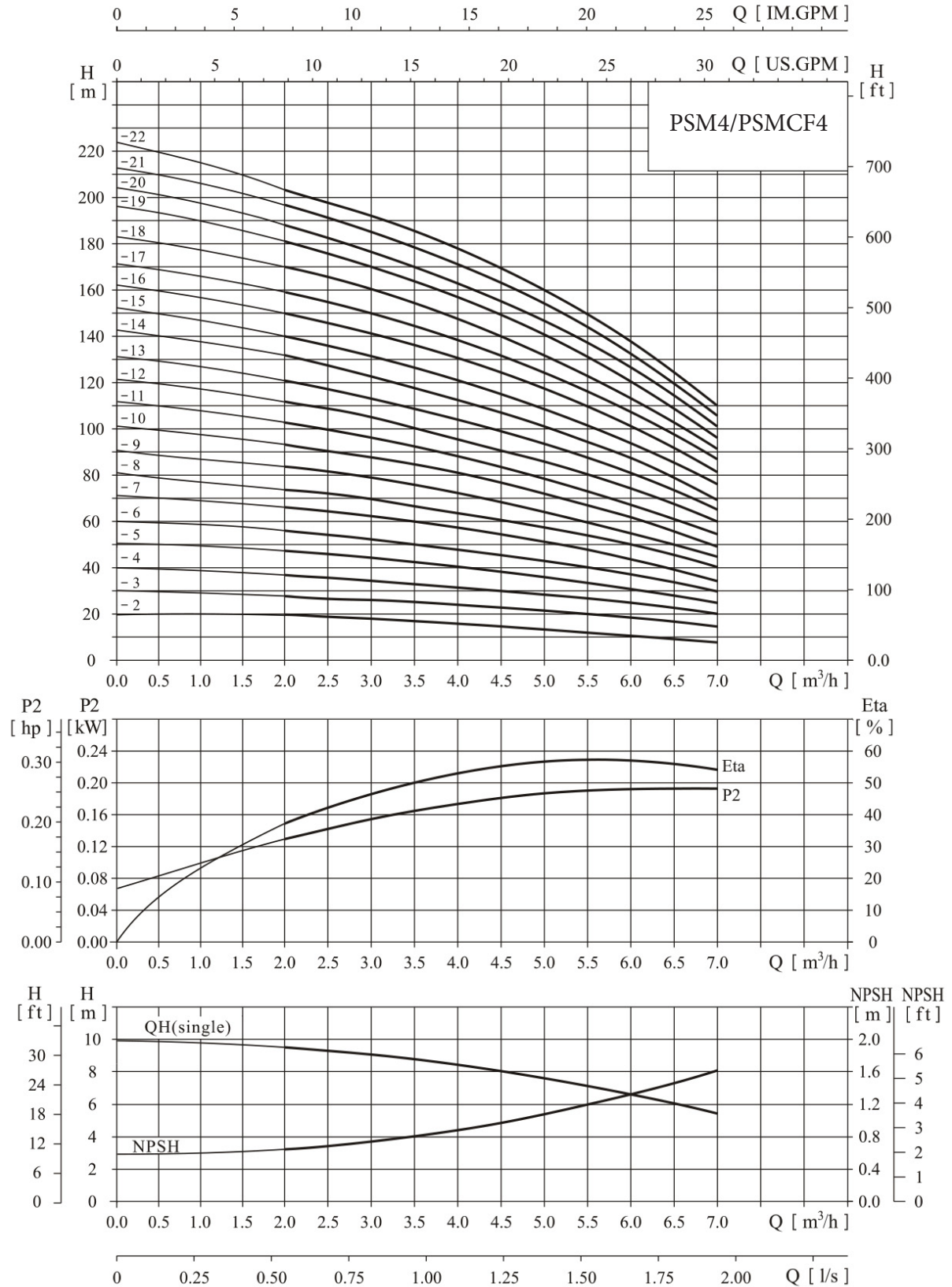

● Performance table

Model	Driving motor		Q (m ³ /h)	1.5	2.0	3.0	4.0	5.0	6.0	7.0
	(kW)	(hp)								
P S M 4	2	0.37	H (m)	19	18	17	15	13	10	8
	3	0.55		28	27	26	24	20	18	13
	4	0.75		38	36	34	32	27	24	19
	5	1.1		47	45	43	40	34	31	23
	6	1.1		56	54	52	48	41	37	28
	7	1.5		66	63	61	56	48	43	33
	8	1.5		74	72	70	64	55	50	38
	10	2.2		96	90	87	81	71	62	48
	12	2.2		114	108	104	95	85	75	58
	14	3.0		136	126	122	112	101	89	68
	16	3.0		152	144	140	129	115	101	78
	19	4.0		183	171	168	153	137	122	93
22	4.0	211	200	192	178	160	138	108		

PSM 4 MODEL	Size (mm)					Size (in)					Weight (kg/lbs)
	B1	B2	B1+B2	D1	D2	B1	B2	B1+B2	D1	D2	
2	276	210	486	148	117	10.87	8.27	19.13	5.83	4.60	21/46.30
3	303	210	513	148	117	11.93	8.27	20.20	5.83	4.60	22/48.50
4	340	245	585	170	142	13.39	9.65	23.03	6.69	5.59	25/55.11
5	367	245	612	170	142	14.45	9.65	24.09	6.69	5.59	27/59.52
6	394	245	639	170	142	15.51	9.65	25.15	6.69	5.59	27/59.52
7	431	290	721	190	155	16.97	11.42	28.39	7.48	6.10	33/72.75
8	458	290	748	190	155	18.03	11.42	29.45	7.48	6.10	33/72.75
10	512	290	802	190	155	20.16	11.42	31.57	7.48	6.10	37/81.57
12	566	290	856	190	155	22.28	11.42	33.70	7.48	6.10	38/83.77
14	630	315	945	197	165	24.80	12.40	37.20	7.76	6.50	46/101.41
16	684	315	999	197	165	26.92	12.40	39.33	7.76	6.50	48/105.82
19	765	335	1100	230	188	30.12	13.18	43.30	9.06	7.40	57/125.66
22	846	335	1181	230	188	33.31	13.18	46.50	9.06	7.40	59/130.07

Installation sketch

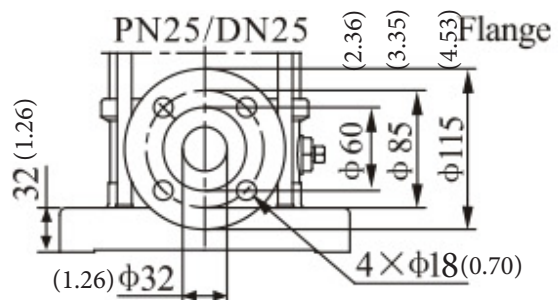
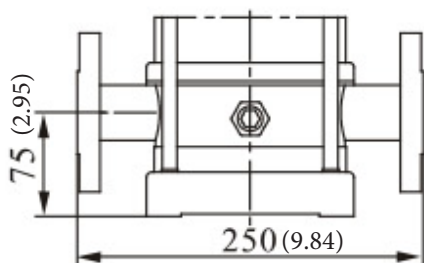
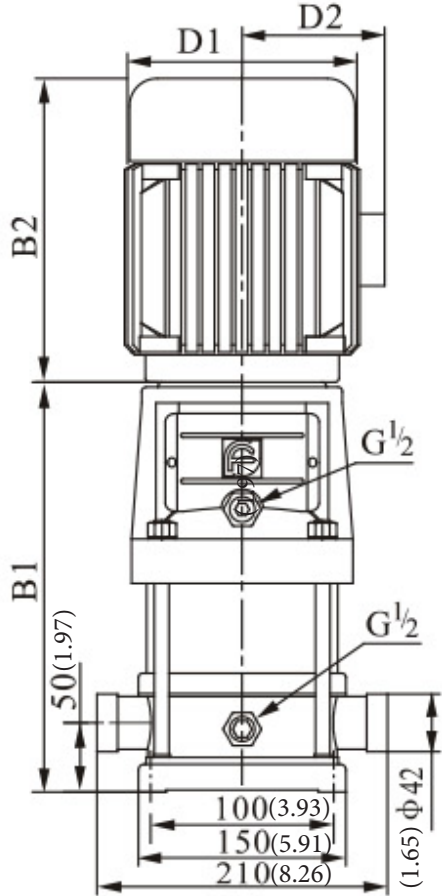



● Performance curve **ISO9906 Annex A 2900rpm**

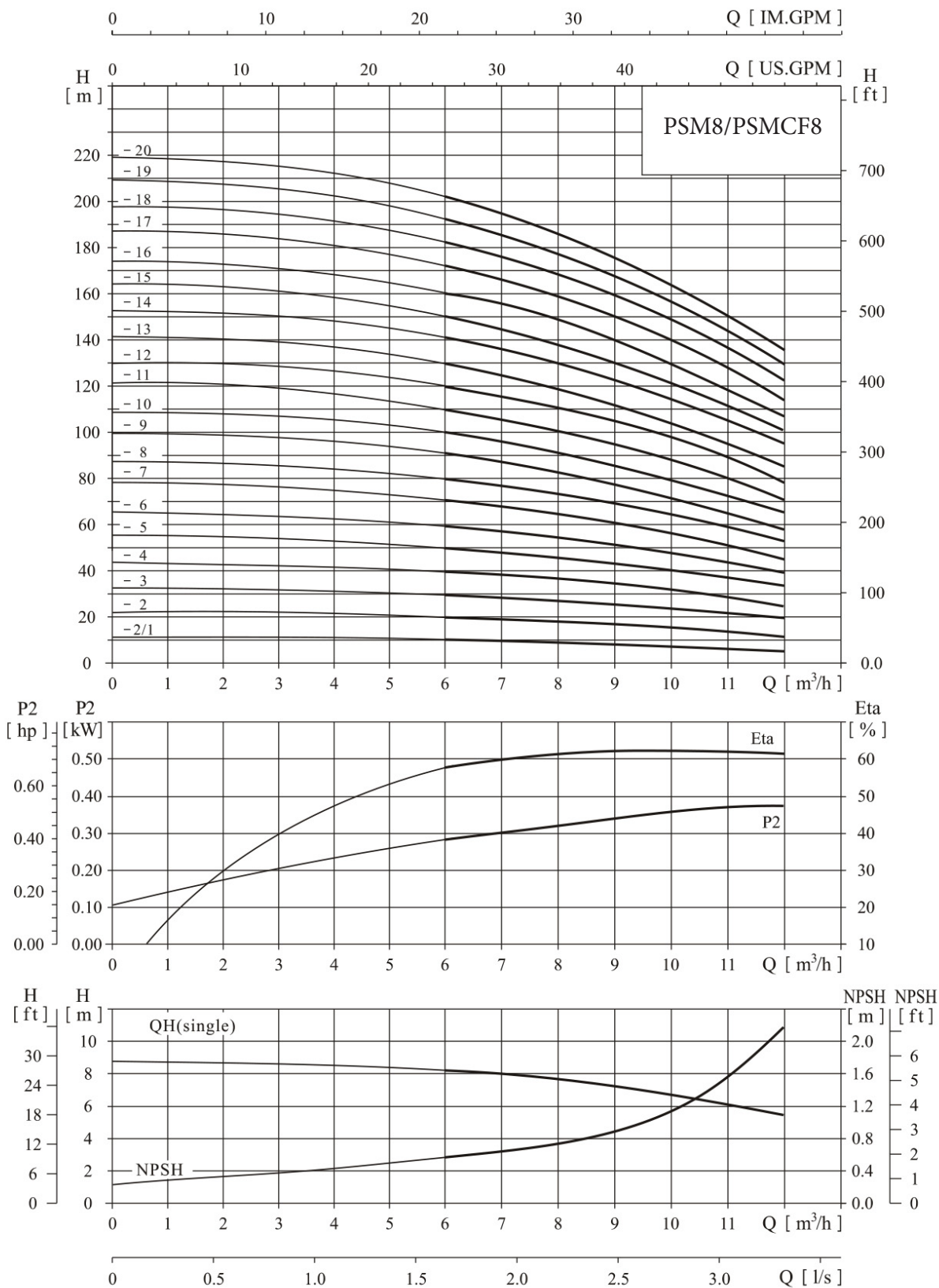

● Performance table

Model	Driving motor		Q (m ³ /h)	5	6	7	8	9	10	11	12
	(kW)	(hp)									
P S M 8	2/1	0.75	1	10	9.5	9.3	9	8.5	8	7	6
	2	0.75	1	20	19.5	19	18	17	16	14	13
	3	1.1	1.5	30	29.5	28.5	27	25	24	21	19
	4	1.5	2	41	39.5	38	36	34	32	28	26
	5	2.2	3	52	50	48	45	42	40	36	32
	6	2.2	3	62	60	57	54	51	48	43	39
	8	3.0	4	83	80	77	73	69	65	58	52
	10	4.0	5.5	104	100	97	92	87	81	73	65
	12	4.0	5.5	124	120	116	111	104	92	87	78
	14	5.5	7.5	145	141	136	130	122	113	102	92
	16	5.5	7.5	166	161	156	148	139	130	118	106
	18	7.5	10	187	182	175	167	157	146	134	120
20	7.5	10	208	202	195	186	175	163	150	135	

PSM 8 MODEL	Size (mm)					Size (in)					Weight (kg/lbs)
	B1	B2	B1+B2	D1	D2	B1	B2	B1+B2	D1	D2	
2/1	347	245	592	170	142	13.66	9.65	23.30	6.69	5.59	32/70.54
2	347	245	592	170	142	13.66	9.65	23.30	6.69	5.59	32/70.54
3	377	245	622	170	142	14.84	9.65	24.49	6.69	5.59	34/74.95
4	417	290	707	190	155	16.42	11.42	27.83	7.48	6.10	40/88.18
5	447	290	737	190	155	17.60	11.42	29.01	7.48	6.10	44/97.00
6	477	290	767	190	155	18.78	11.42	30.20	7.48	6.10	45/99.20
8	547	315	862	197	165	21.54	12.40	33.94	7.76	6.50	53/116.84
10	607	335	942	230	188	23.90	13.19	37.09	9.05	7.40	64/141.10
12	667	335	1002	230	188	26.25	13.19	39.45	9.05	7.40	66/145.50
14	747	430	1177	260	208	29.41	16.93	46.34	10.24	8.19	81/178.57
16	807	430	1237	260	208	31.77	16.93	48.70	10.24	8.19	84/185.18
18	867	430	1297	260	208	34.13	16.93	51.06	10.24	8.19	93/205.03
20	927	430	1357	260	208	36.49	16.93	54.06	10.24	8.19	94/207.23

Installation sketch

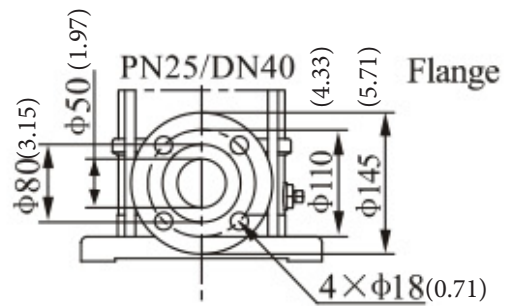
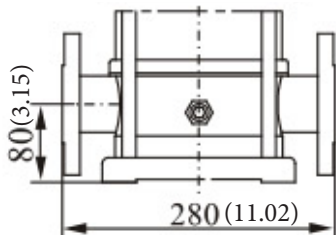
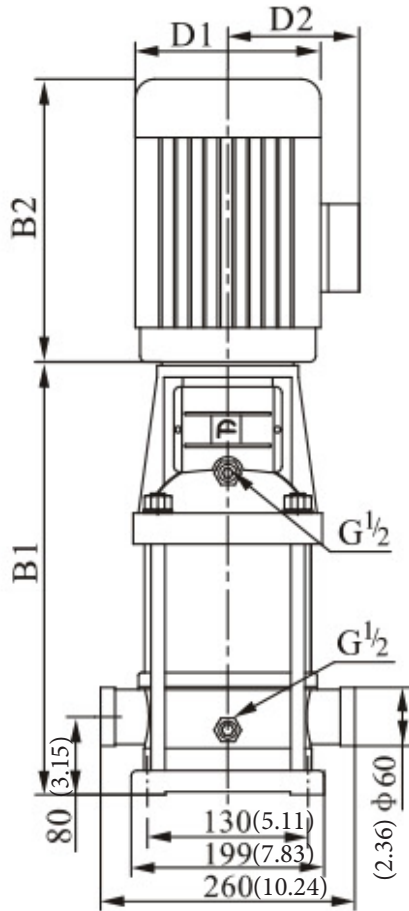



● Performance curve

ISO9906 Annex A 2900rpm

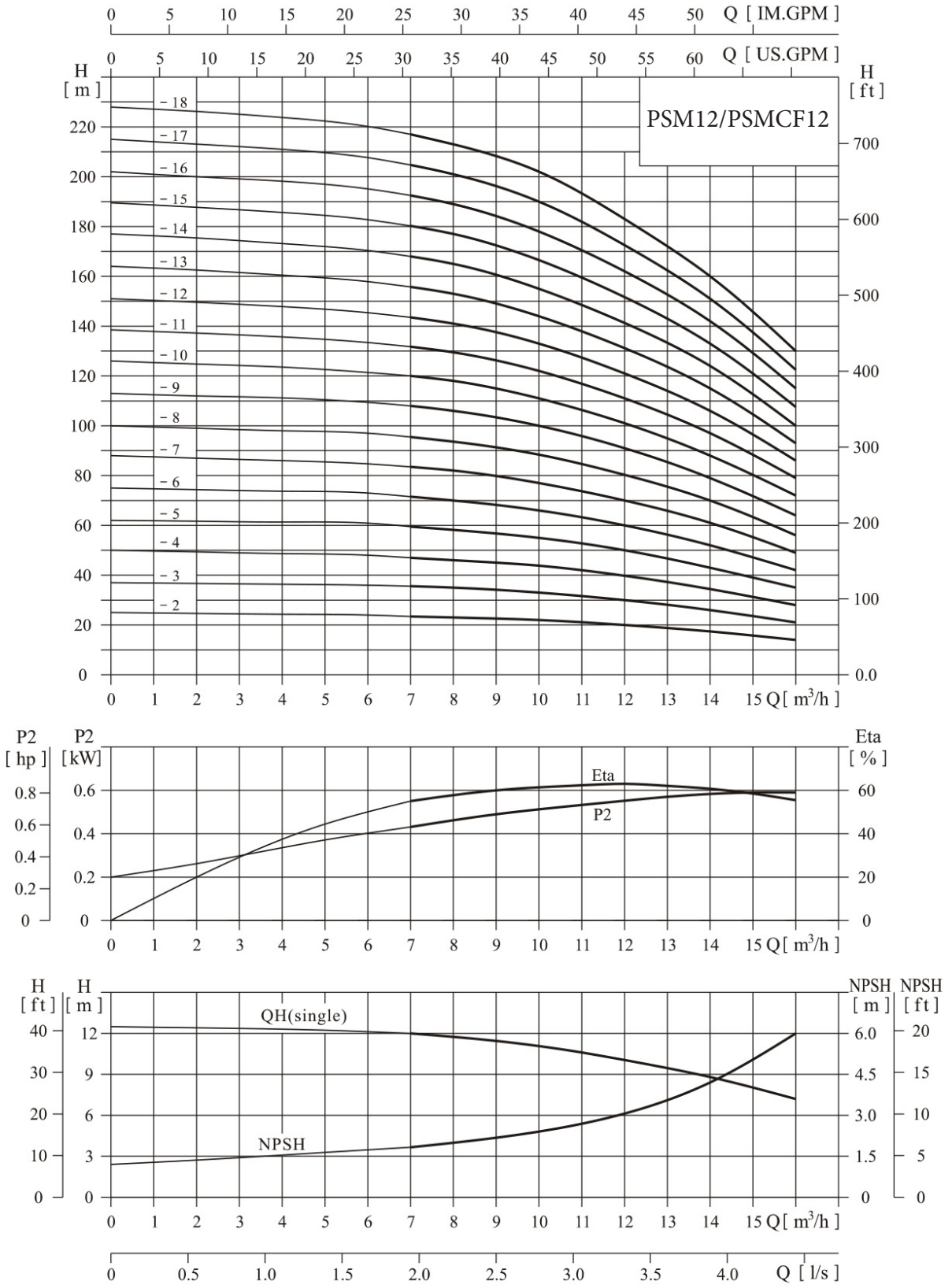

● Performance table

Model	Driving motor		Q (m ³ /h)	7	8	9	10	11	12	13	14	15	16	
	(kW)	(hp)												
P S M 12	2	1.5	2	H (m)	23.5	23	22.5	22	21	20	18.5	17	15.5	14
	3	2.2	3		35.5	35	34	33	31.5	30	28	26	23.5	21
	4	3	4		47	46	45	44	42	40	37	34	31	28
	5	3	4		59.5	58	56.5	55	52.5	50	46.5	43	39	35
	6	4	5.5		71.5	70	68	66	63	60	56	52	47	42
	7	5.5	7.5		83.5	82	79.5	77	73.5	70	65.5	61	55	49
	8	5.5	7.5		95.5	94	91	88	84	80	75	70	63	56
	9	5.5	7.5		108	106	103	100	95.5	91	85	79	71.5	64
	10	7.5	10		120	118	114.5	111	106	101	94.5	88	80	72
	12	7.5	10		143.5	141	137	133	127	121	113.5	106	96	86
	14	11	15		168	165	160	155	148	141	132.5	124	112	100
	16	11	15		192.5	189	183.5	178	170	162	152	142	128.5	115
18	11	15	217	213	207.5	202	192.5	183	171.5	160	145	130		

PSM 12 MODEL	Size (mm)					Size (in)					Weight (kg/lbs)
	B1	B2	B1+B2	D1	D2	B1	B2	B1+B2	D1	D2	
2	367	290	657	190	155	14.44	11.41	25.87	7.48	6.10	39/85.98
3	397	290	687	190	155	15.63	11.41	27.04	7.48	6.10	43/94.80
4	437	315	752	197	165	17.20	12.40	29.65	7.76	6.50	51/112.43
5	467	315	782	197	165	18.39	12.40	30.78	7.76	6.50	53/116.84
6	497	335	832	230	188	19.57	13.18	32.76	9.05	7.40	61/134.48
7	547	430	977	260	208	21.54	16.92	38.46	10.24	8.19	73/160.93
8	577	430	1007	260	208	22.71	16.92	39.65	10.24	8.19	74/163.14
9	607	430	1037	260	208	23.90	16.92	40.83	10.24	8.19	76/167.55
10	637	430	1067	260	208	25.08	16.92	42.00	10.24	8.19	83/182.98
12	697	430	1127	260	208	27.44	16.92	44.37	10.24	8.19	87/191.80
14	845	490	1335	330	255	33.27	19.29	52.56	12.99	10.03	157/346.13
16	905	490	1395	330	255	35.63	19.29	54.92	12.99	10.03	161/354.94
18	965	490	1455	330	255	37.99	19.29	57.28	12.99	10.03	164/361.56



● Performance curve **ISO9906 Annex A 2900rpm**

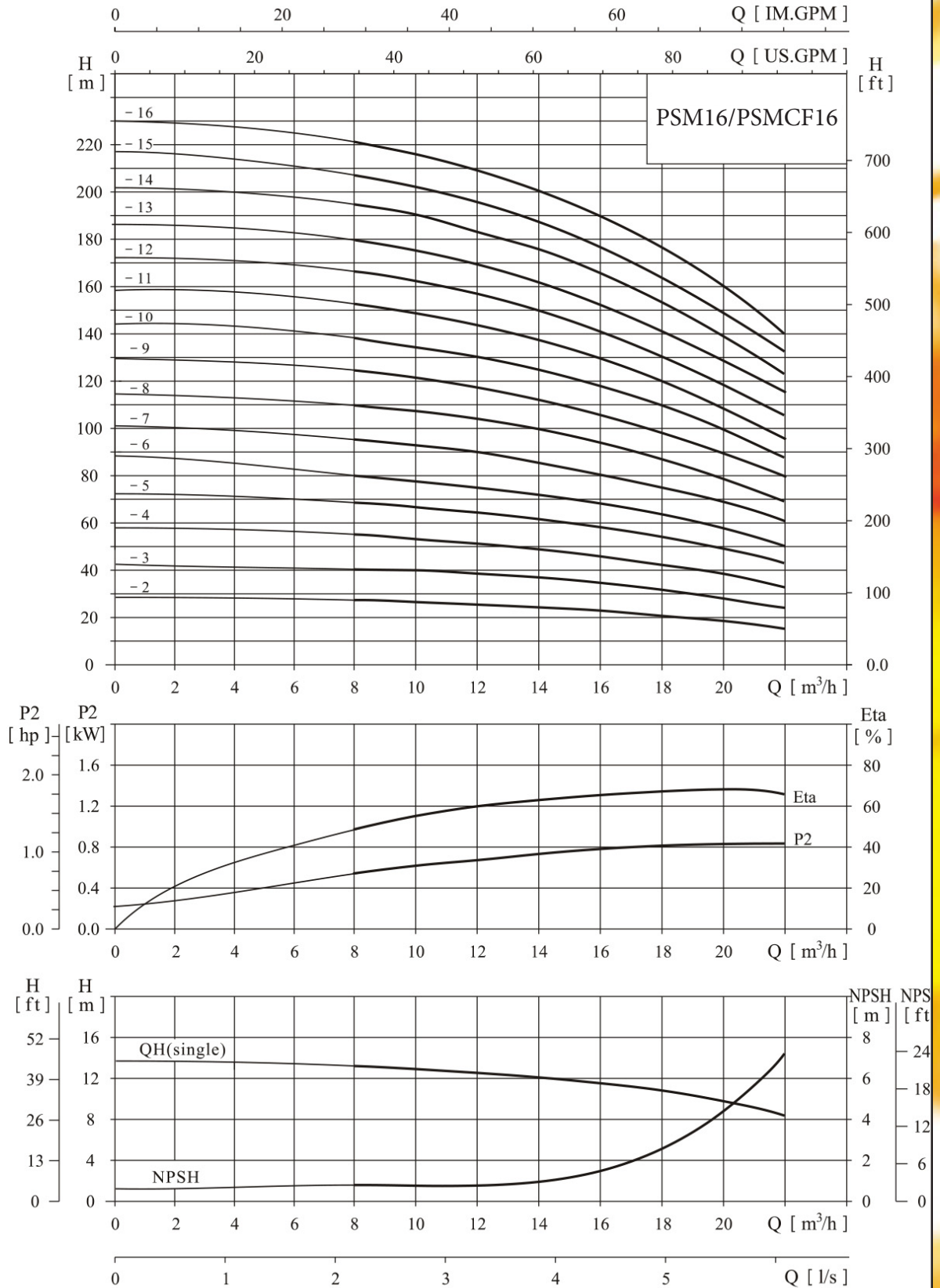

● Performance table

Model	Driving motor		Q (m ³ /h)	8	10	12	14	16	18	20	22	
	(kW)	(hp)										
P S M 16	2	2.2	3	H (m)	27	26	25	24	22	21	19	16
	3	3.0	4		41	40	38	37	34	32	29	25
	4	4.0	5.5		54	53	52	49	46	43	38	34
	5	5.5	7.5		68	67	65	62	58	54	48	43
	6	5.5	7.5		82	80	78	74	70	64	58	52
	7	7.5	10		96	95	91	87	82	76	68	61
	8	7.5	10		110	108	104	99	94	86	77	70
	10	11	15		138	136	131	125	118	109	97	87
	12	11	15		166	162	157	150	141	130	116	105
	14	15	20		194	190	184	175	166	152	136	122
16	15	20	222	217	210	200	189	174	156	140		

PSM 16 MODEL	Size (mm)					Size (in)					Weight (kg/lbs)
	B1	B2	B1+B2	D1	D2	B1	B2	B1+B2	D1	D2	
2	397	290	687	190	155	15.63	11.41	27.04	7.48	6.10	42/92.59
3	452	315	767	197	165	17.80	12.40	34.13	7.76	6.50	50/110.23
4	497	335	832	230	188	19.57	13.19	32.76	9.05	7.40	59/130.07
5	562	430	992	260	208	22.13	16.93	39.05	10.24	8.19	76/167.55
6	607	430	1037	260	208	23.90	16.93	40.83	10.24	8.19	77/169.75
7	652	430	1082	260	208	25.67	16.93	42.60	10.24	8.19	84/185.18
8	697	430	1127	260	208	27.44	16.93	44.37	10.24	8.19	86/189.60
10	875	490	1365	330	255	34.45	19.29	53.74	12.99	10.03	158/348.33
12	965	490	1455	330	255	37.99	19.29	57.28	12.99	10.03	161/354.94
14	1055	490	1545	330	255	41.54	19.29	60.83	12.99	10.03	174/383.60
16	1145	490	1635	330	255	45.08	19.29	64.37	12.99	10.03	178/392.42

● Installation sketch

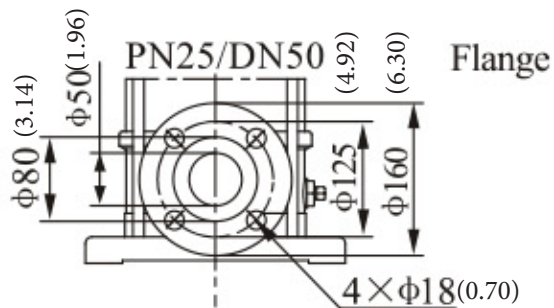
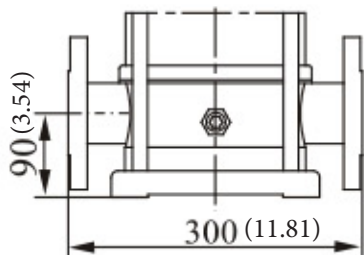
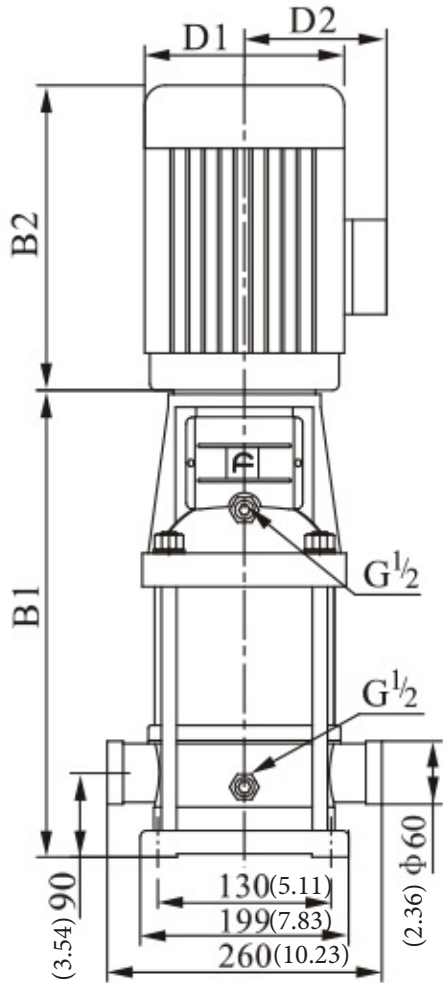



● Performance curve

ISO9906 Annex A 2900rpm

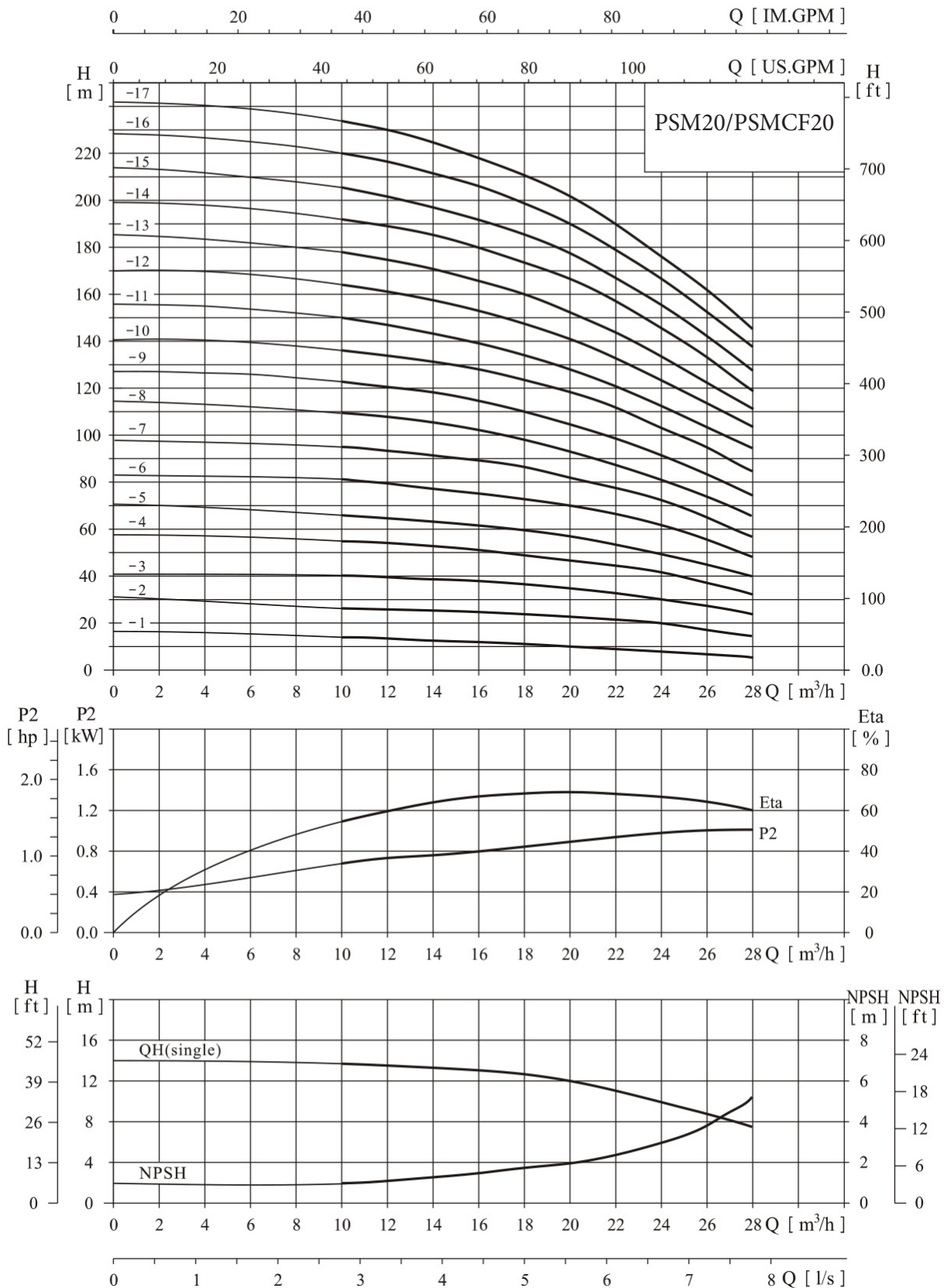

● Performance table

Model	Driving motor		Q (m ³ /h)	10	12	14	16	18	20	22	24	26	28	
	(kW)	(hp)												
P S M 20	1	1.1	1.5	H (m)	13.5	13	12.5	12	11	10	9	8	7	6
	2	2.2	3		27	26.5	26	25	24	23	22	20	18	15
	3	4.0	5.5		40	39.5	39	38	37	35	33	30	27	24
	4	5.5	7.5		54	53	52	51	49	47	44	41	37	33
	5	5.5	7.5		67	66	64	62	60	58	55	50	45	40
	6	7.5	10		81	79	77	75	73	70	66	61	55	49
	7	7.5	10		95	93	91	89	86	82	77	71	65	58
	8	11	15		109	107	105	102	99	94	89	82	75	67
	10	11	15		136	134	131	128	124	118	111	103	95	85
	12	15	20		164	162	158	154	149	142	133	124	114	102
	14	15	20		192	189	185	180	174	166	156	145	133	119
	17	18.5	25		234	230	225	219	212	202	190	177	162	145

PSM 20 MODEL	Size (mm)					Size (in)					Weight (kg/lbs)
	B1	B2	B1+B2	D1	D2	B1	B2	B1+B2	D1	D2	
1	387	245	632	170	142	15.24	9.65	24.88	6.69	5.59	33/72.75
2	397	290	687	190	155	15.63	11.41	27.04	7.48	6.10	42/92.59
3	452	335	787	230	188	17.80	13.19	30.98	9.06	7.40	58/127.87
4	517	430	947	260	208	20.35	16.93	37.28	10.24	8.19	74/163.14
5	562	430	992	260	208	22.13	16.93	39.05	10.24	8.19	76/167.55
6	607	430	1037	260	208	23.90	16.93	40.83	10.24	8.19	82/180.78
7	652	430	1082	260	208	25.67	16.93	42.60	10.24	8.19	84/185.88
8	785	490	1275	260	208	30.90	19.29	50.20	10.24	8.19	153/337.31
10	875	490	1365	330	255	34.45	19.29	53.74	12.99	10.03	157/346.13
12	965	490	1455	330	255	37.99	19.29	57.28	12.99	10.03	170/374.79
14	1055	490	1545	330	255	41.54	19.29	60.83	12.99	10.03	172/379.20
17	1190	550	1740	330	255	46.85	21.65	68.50	12.99	10.03	195/429.90

Installation sketch

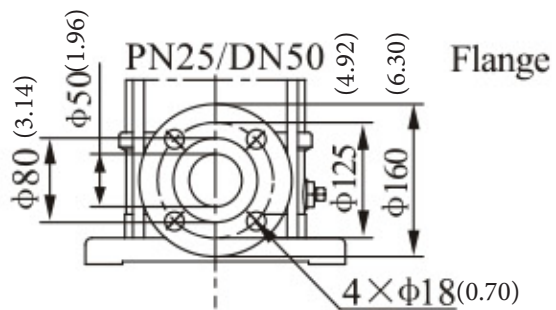
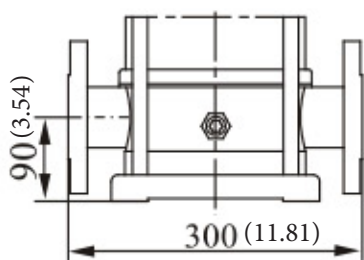
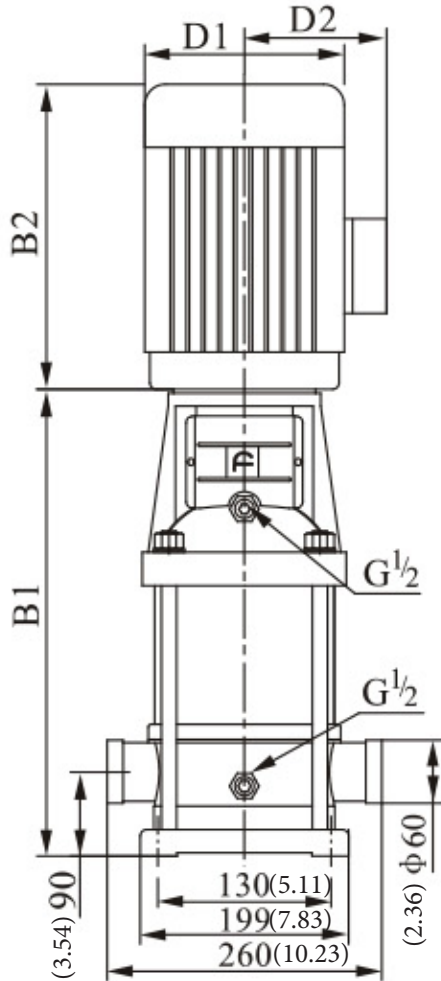



● Performance curve **ISO9906 Annex A 2900rpm**

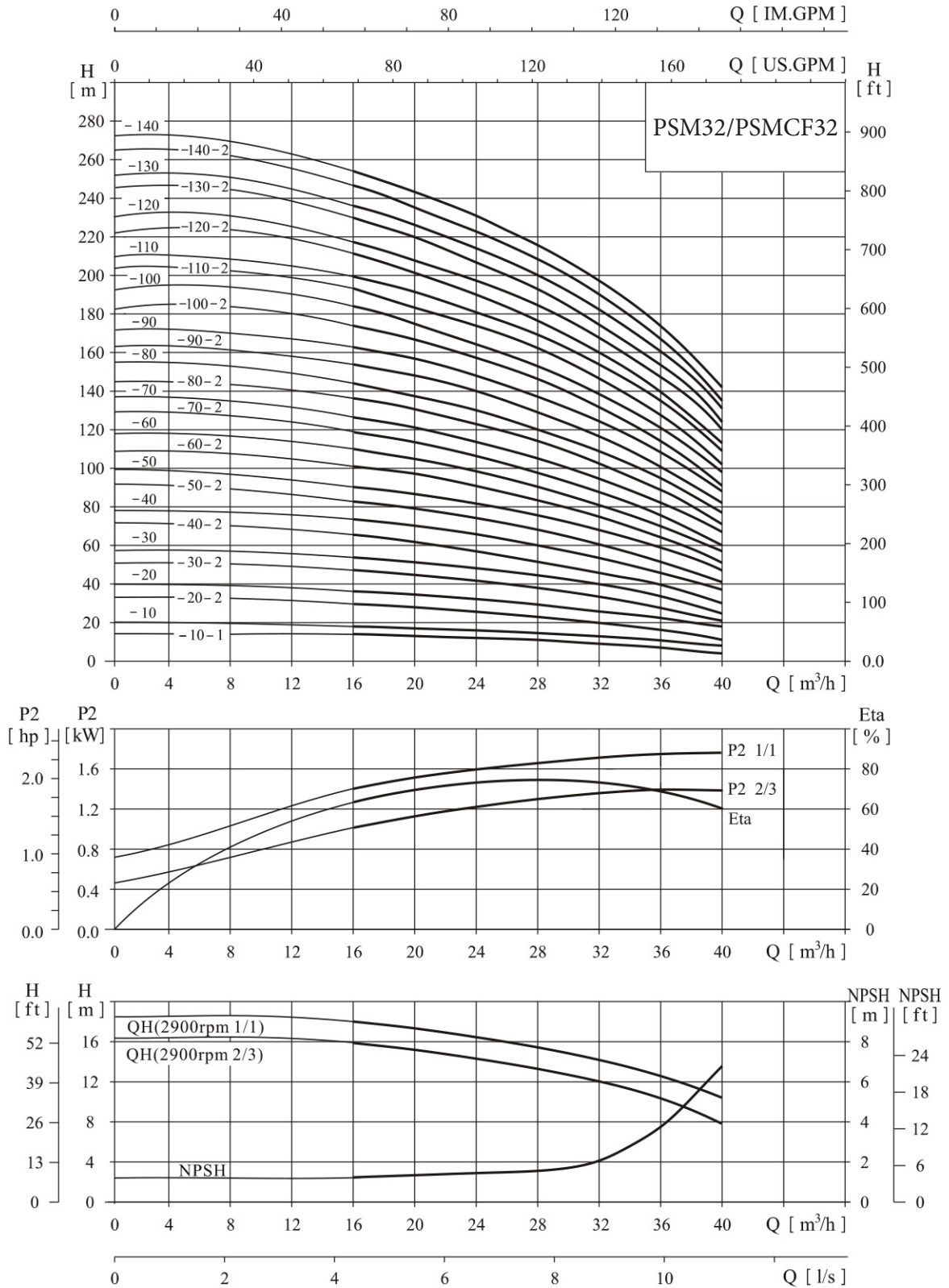



Performance table

Model	Driving motor		Q (m ³ /h)	16	20	24	28	32	36	40	Model	Driving motor		Q (m ³ /h)	16	20	24	28	32	36	40		
	(kW)	(hp)										(kW)	(hp)										
P S M	32-10-1	1.5	2	H (m)	14	13	12	11	9	7	4	CDL32-80-2	15	20	H (m)	136	131	123	114	102	90	71	
	32-10	2.2	3		18	17	15	14	13	11	8	8	CDL32-80	15		20	144	138	130	120	109	97	77
	32-20-2	3.0	4		29	28	26	23	20	16	11	11	CDL32-90-2	18.5		25	154	148	140	129	117	102	82
	32-20	4.0	5.5		36	34	32	29	27	23	18	18	CDL32-90	18.5		25	162	156	147	136	124	109	88
	32-30-2	5.5	7.5		47	44	41	38	33	28	21	21	CDL32-100-2	18.5		25	175	166	157	146	131	115	91
	32-30	5.5	7.5		54	51	48	44	40	35	27	27	CDL32-100	18.5		25	182	173	164	152	138	122	98
	32-40-2	7.5	10		65	62	58	53	46	40	30	30	CDL32-110-2	22		30	193	184	173	164	146	128	102
	32-40	7.5	10		72	69	65	59	53	47	37	37	CDL32-110	22		30	200	191	180	168	153	135	109
	32-50-2	11	15		83	79	74	68	60	52	41	41	CDL32-120-2	22		30	211	201	189	178	160	140	113
	32-50	11	15		90	86	81	74	67	59	47	47	CDL32-120	22		30	218	208	196	184	167	147	120
	32-60-2	11	15		101	97	90	83	74	65	51	51	CDL32-130-2	30		40	230	218	206	193	174	153	124
	32-60	11	15		108	104	97	90	81	72	57	57	CDL32-130	30		40	237	225	213	200	181	160	131
	32-70-2	15	20		119	114	107	98	88	78	60	60	CDL32-140-2	30		40	247	235	222	210	189	165	135
	32-70	15	20		126	121	113	105	95	85	67	67	CDL32-140	30		40	255	242	229	216	196	172	142

PSM 32 MODEL	Size (mm)					Size (in)					Weight (kg/lbs)
	B1	B2	B1+B2	D1	D2	B1	B2	B1+B2	D1	D2	
PSM-32-10-1/ PSMCF-32-10	505	290	795	190	155	19.88	11.41	31.30	7.48	6.10	64/68 141.09/ 149.91
PSM-32-20-2/ PSMCF-32-20	575	315/335	890/910	197/230	165/180	22.64	12.40/13.19	35.03/35.83	7.76/9.06	6.50/7.08	77/85 169.75/ 187.39
PSM-32-30-2/ PSMCF-32-30	645	430	1075	260	208	25.39	16.93	42.32	10.24	8.19	100/220.46
PSM-32-40-2/ PSMCF-32-40	715	430	1145	260	208	28.15	16.93	45.08	10.24	8.19	109/240.30
PSM-32-50-2/ PSMCF-32-50	890	490	1380	330	255	35.03	19.29	54.33	12.99	10.04	181/399.03
PSM-32-60-2/ PSMCF-32-60	960	490	1450	330	255	37.79	19.29	57.08	12.99	10.04	185/407.85
PSM-32-70-2/ PSMCF-32-70	1030	490	1520	330	255	40.55	19.29	59.84	12.99	10.04	199/438.72
PSM-32-80-2/ PSMCF-32-80	1100	490	1590	330	255	43.31	19.29	62.60	12.99	10.04	203/447.53
PSM-32-90-2/ PSMCF-32-90	1170	550	1720	330	255	46.06	21.65	67.72	12.99	10.04	222/489.42
PSM-32-100-2/ PSMCF-32-100	1240	550	1790	330	255	48.81	21.65	70.47	12.99	10.04	227/500.44
PSM-32-110-2/ PSMCF-32-110	1310	590	1900	360	285	51.57	23.23	74.80	14.17	11.22	272/599.66
PSM-32-120-2/ PSMCF-32-120	1380	590	1970	360	285	54.33	23.23	77.56	14.17	11.22	276/608.48
PSM-32-130-2/ PSMCF-32-130	1450	660	2110	400	310	57.09	25.98	83.07	15.75	12.20	337/742.96
PSM-32-140-2/ PSMCF-32-140	1520	660	2180	400	310	59.84	25.98	85.83	15.75	12.20	341/751.78

Installation sketch

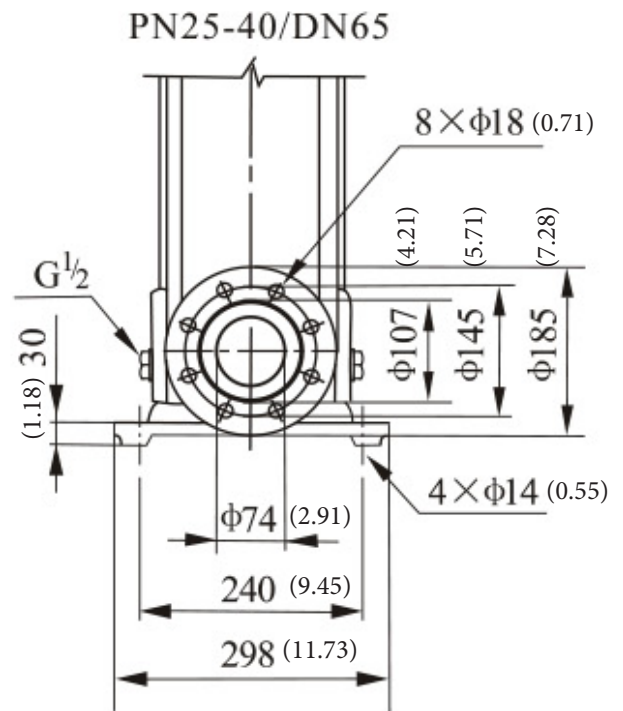
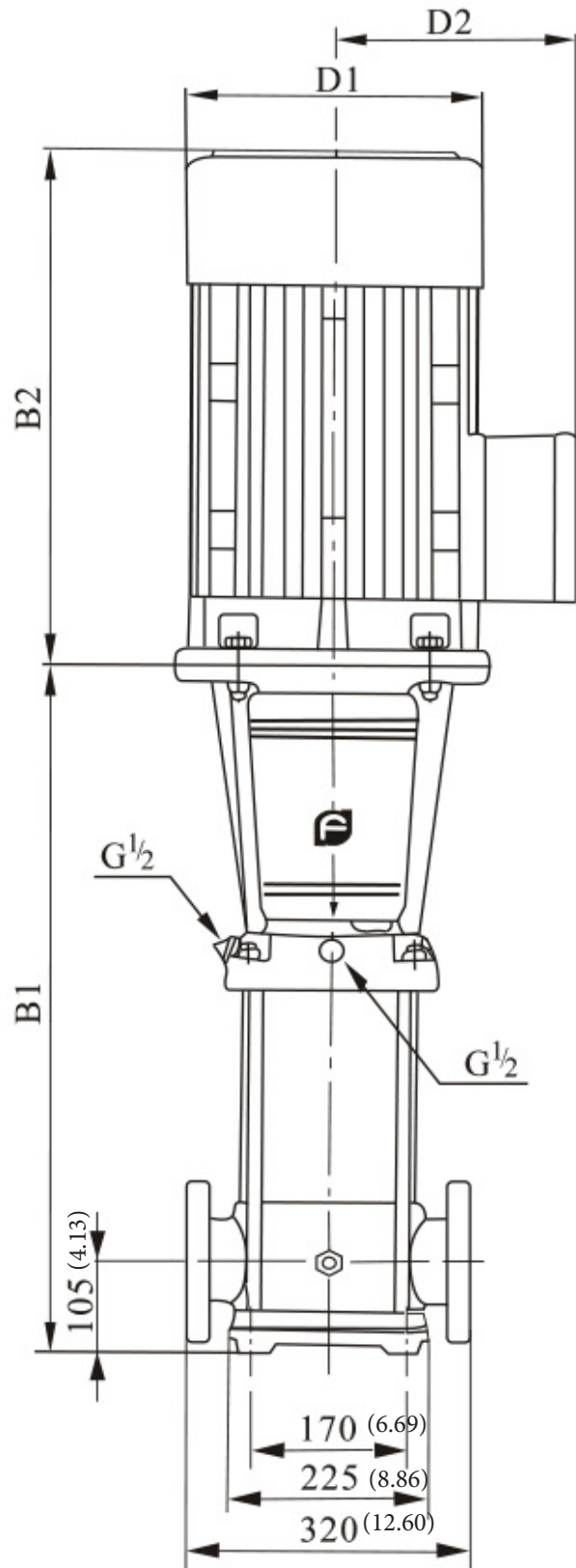



● Performance curve ISO9906 Annex A 2900rpm

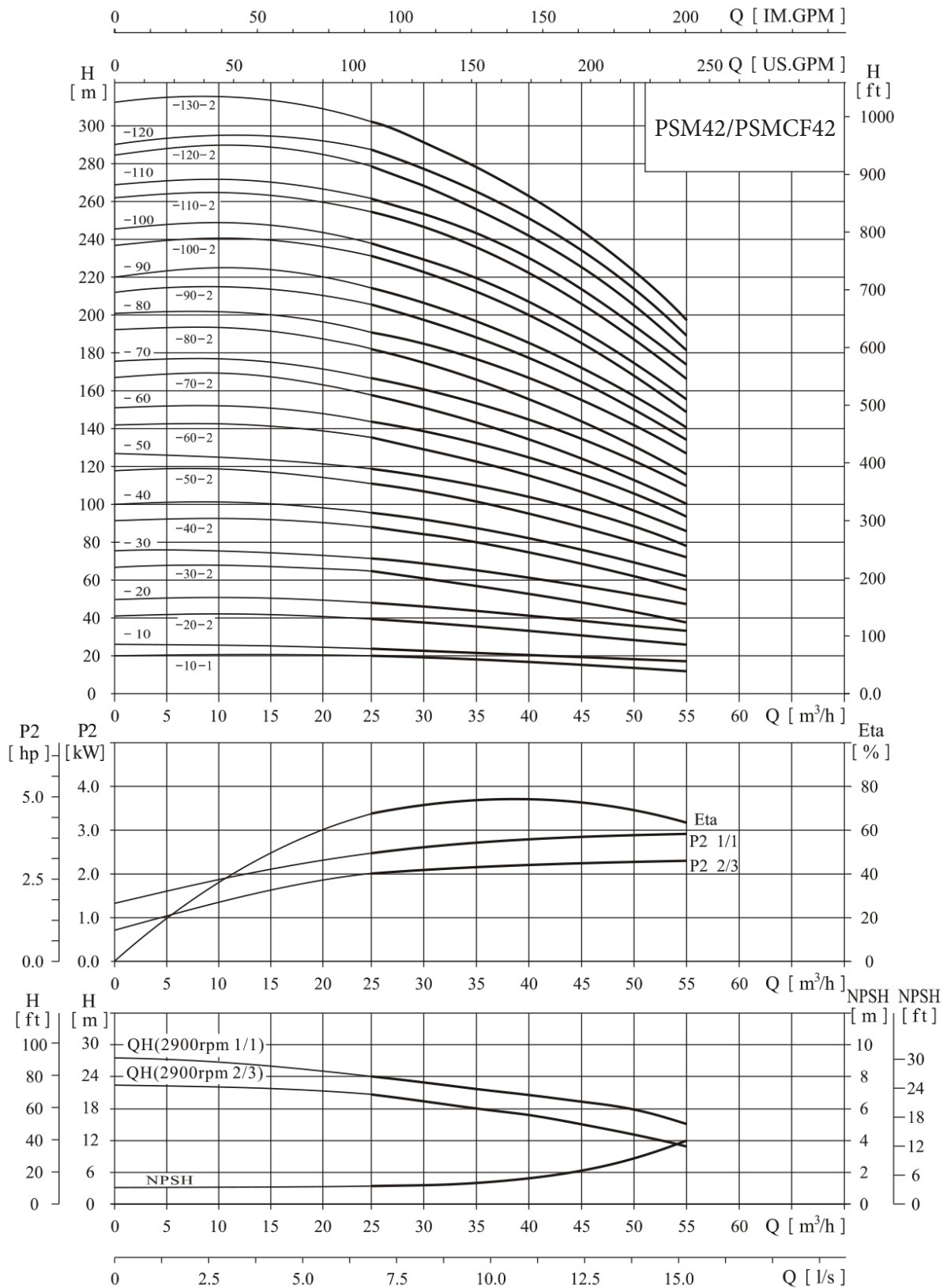

Performance table

Model	Driving motor		Q (m ³ /h)	25	30	35	40	42	45	50	55
	(kW)	(hp)									
42-10-1	3.0	4	H (m)	20	19	18	17	16	15	13	11
42-10	4.0	5.5		24	23	22	21	20	19	18	16
42-20-2	5.5	7.5		40	38	36	33	32	30	27	23
42-20	7.5	10		48	46	44	42	41	39	35	31
42-30-2	11	15		63	61	58	54	52	50	44	38
42-30	11	15		71	69	66	63	61	58	53	47
42-40-2	15	20		87	84	80	75	73	69	62	54
42-40	15	20		95	92	88	84	81	78	71	62
42-50-2	18.5	25		111	107	102	96	93	88	80	69
42-50	18.5	25		119	115	110	105	101	97	88	78
42-60-2	22	30		135	130	124	117	113	108	97	85
42-60	22	30		143	138	132	125	122	116	106	93
42-70-2	30	40		158	152	146	138	134	127	115	100
42-70	30	40		166	161	154	146	142	135	124	109
42-80-2	30	40		182	175	168	159	154	146	133	116
42-80	30	40		190	184	176	167	162	154	141	124
42-90-2	30	40		205	198	190	180	174	166	150	132
42-90	37	50		214	207	198	188	183	174	159	140
42-100-2	37	50		230	221	212	200	194	185	168	147
42-100	37	50		238	230	220	209	203	193	177	155
42-110-2	45	60	255	246	236	223	217	206	188	165	
42-110	45	60	263	255	244	232	225	214	196	173	
42-120-2	45	60	280	270	259	245	238	226	206	181	
42-120	45	60	289	280	268	255	247	236	216	190	
42-130-2	45	60	305	294	282	267	259	247	225	198	

PSM 42 MODEL	Size (mm)					Size (in)					Weight (kg/lbs)
	B1	B2	B1+B2	D1	D2	B1	B2	B1+B2	D1	D2	
PSM-42-10-1 PSM-42-10	561	315/335	876/896	197/230	165/188	22.08	12.40/ 13.19	34.48/ 35.28	7.76/ 9.05	6.50/ 7.40	83/90 182.98/ 198.42
PSM-42-20-2 PSM-42-20	641	430	1071	260	208	25.24	16.93	42.17	10.23	8.19	105/110 231.49/ 242.50
PSM-42-30-2 PSM-42-30	826	490	1316	330	255	32.52	19.29	51.81	12.99	10.04	183/403.44
PSM-42-40-2 PSM-42-40	906	490	1396	330	255	35.67	19.29	54.96	12.99	10.04	197/654.77
PSM-42-50-2 PSM-42-50	986	550	1536	330	255	38.82	21.65	60.47	12.99	10.04	221/487.22
PSM-42-60-2 PSM-42-60	1066	590	1656	360	285	41.97	23.23	65.20	14.17	11.22	261/575.40
PSM-42-70-2 PSM-42-70	1146	660	1806	400	310	45.12	25.98	71.10	15.75	12.20	320/705.48
PSM-42-80-2 PSM-42-80	1226	660	1886	400	310	48.27	25.98	74.25	15.75	12.20	324/714.30
PSM-42-90-2 PSM-42-90	1306	660	1966	400	310	51.42	25.98	77.40	15.75	12.20	328/352 723.12 /776.02
PSM-42-100-2 PSM-42-100	1386	660	2046	400	310	54.57	25.98	80.55	15.75	12.20	355/782.64
PSM-42-110-2 PSM-42-110	1466	700	2166	450	345	57.72	27.55	85.28	17.72	13.58	426/939.16
PSM-42-120-2 PSM-42-120	1546	700	2246	450	345	60.87	27.55	88.42	17.72	13.58	432/952.40
PSM-42-130-2	1626	700	2326	450	345	64.02	27.55	91.57	17.72	13.58	438/965.63

P
S
M
4
2

Installation sketch

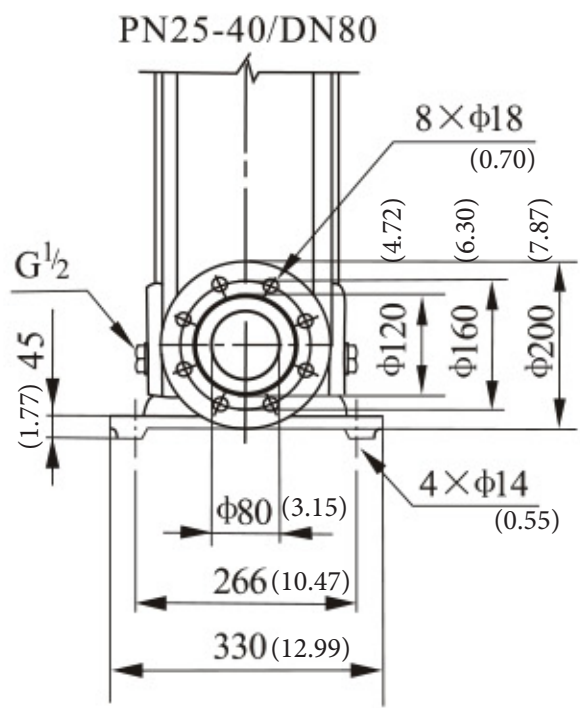
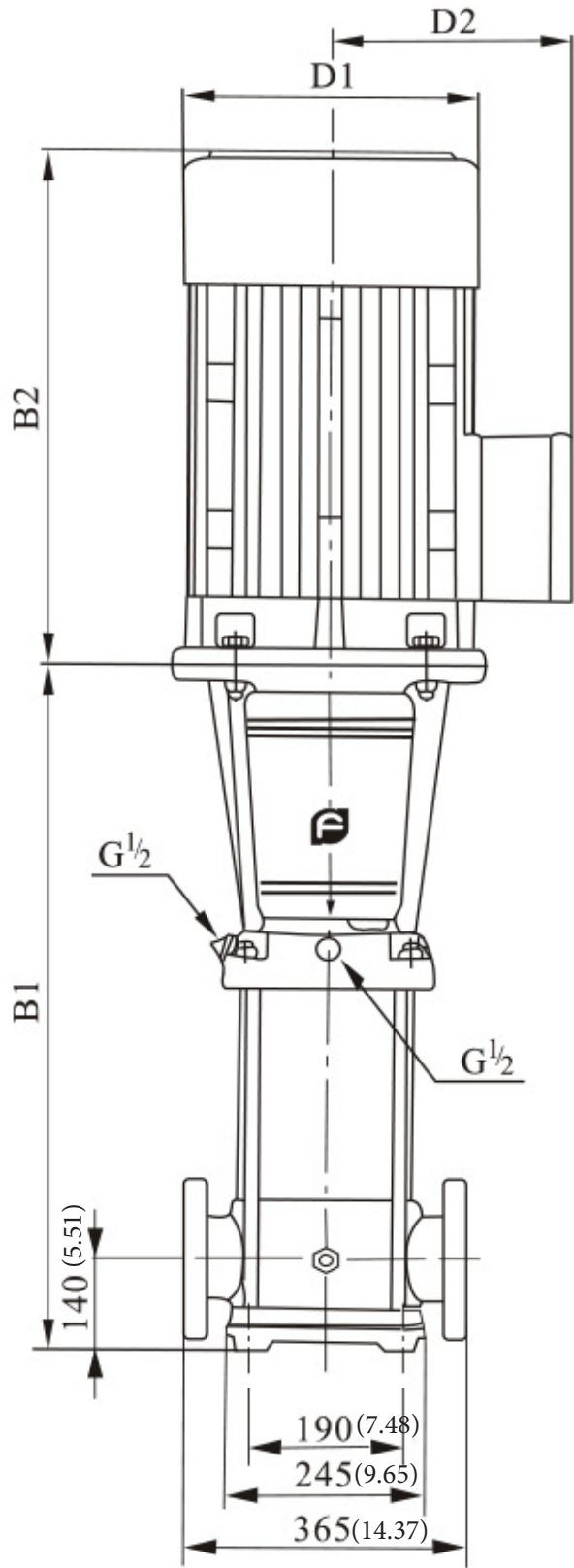



Performance curve ISO9906 Annex A 2900rpm

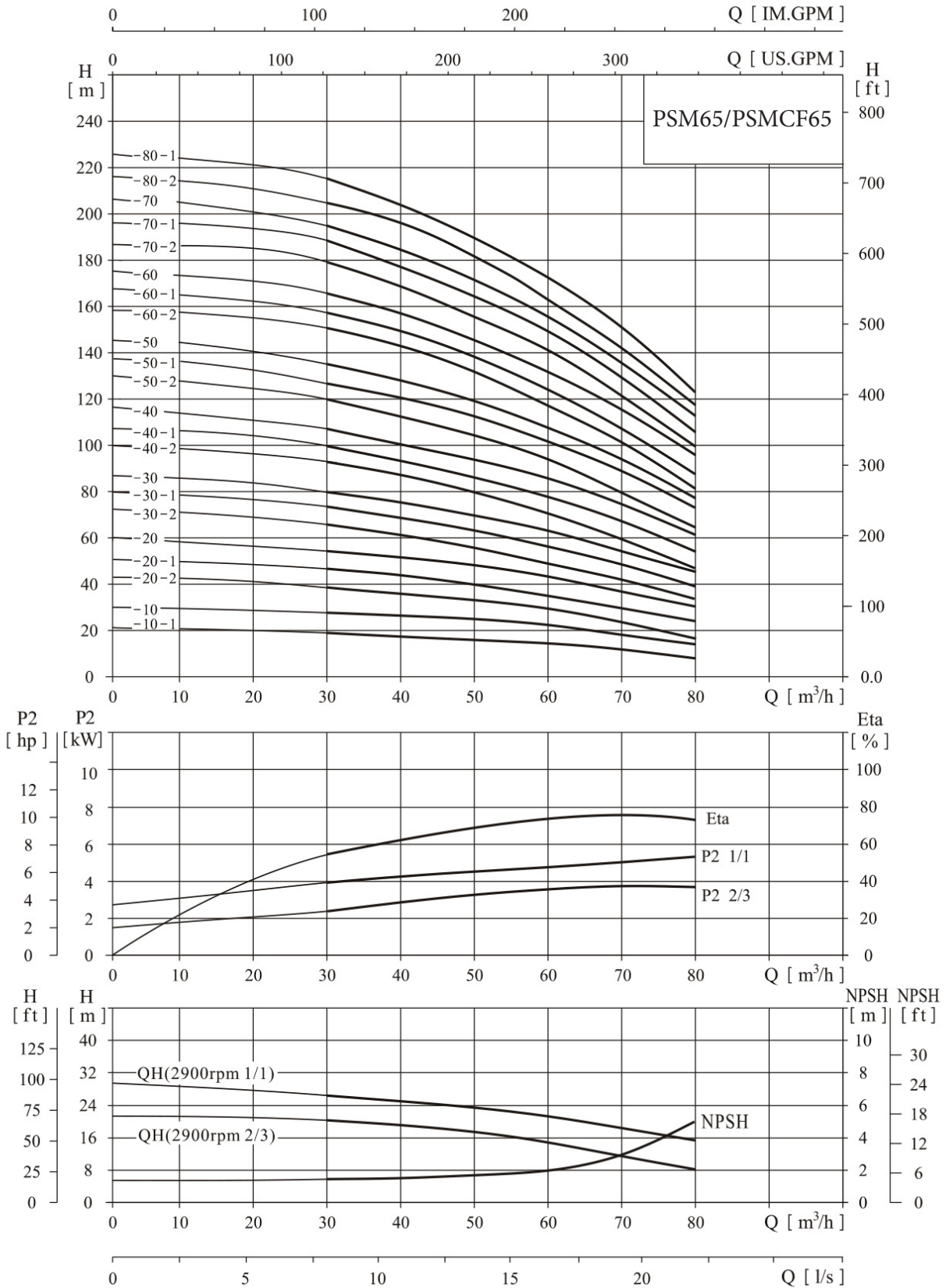

Performance table

Model	Driving motor		Q (m ³ /h)	30	40	50	60	65	70	80
	(kW)	(hp)								
P S M	65-10-1	4.0	5.5	19	18	16	14	13	11	8
	65-10	5.5	7.5	27	25	23	21	20	18	15
	65-20-2	7.5	10	39	36	33	29	26	23	17
	65-20-1	11	15	46	44	40	36	33	30	24
	65-20	11	15	53	51	47	43	40	37	30
	65-30-2	15	20	66	62	56	50	46	41	32
	65-30-1	15	20	73	69	63	57	53	48	39
	65-30	18.5	25	80	76	70	64	60	55	46
	65-40-2	18.5	25	92	87	80	71	66	60	47
	65-40-1	22	30	100	94	87	78	73	67	54
	65-40	22	30	107	101	94	85	80	74	61
	65-50-2	30	40	121	114	105	95	88	80	64
	65-50-1	30	40	128	121	112	102	95	87	71
	65-50	30	40	136	129	119	109	102	94	78
	65-60-2	30	40	150	142	131	118	110	101	81
	65-60-1	37	50	157	149	138	125	117	108	88
	65-60	37	50	164	156	145	132	124	115	95
	65-70-2	37	50	179	169	156	141	132	121	99
	65-70-1	37	50	186	176	163	148	139	128	106
	65-70	45	60	193	183	170	155	146	135	112
	65-80-2	45	60	207	196	182	164	154	142	116
	65-80-1	45	60	215	203	189	171	161	149	123

PSM 65 MODEL	Size (mm)					Size (in)					Weight (kg)
	B1	B2	B1+B2	D1	D2	B1	B2	B1+B2	D1	D2	
65-10-1	561	335	896	230	188	22.09	13.19	35.28	9.06	7.40	93/205.03
65-10	561	430	991	260	208	22.09	16.92	39.01	10.24	8.19	105/231.49
65-20-2	644	430	1074	260	208	25.35	16.92	42.28	10.24	8.19	110/242.51
65-20-1	754	490	1244	330	255	29.69	19.29	48.98	12.99	10.04	182/401.24
65-20	754	490	1244	330	255	29.69	19.29	48.98	12.99	10.04	182/401.24
65-30-2	836	490	1326	330	255	32.91	19.29	52.20	12.99	10.04	196/432.10
65-30-1	836	490	1326	330	255	32.91	19.29	52.20	12.99	10.04	197/434.31
65-30	836	550	1386	330	255	32.91	21.65	54.57	12.99	10.04	221/487.22
65-40-2	919	550	1469	330	255	36.18	21.65	57.83	12.99	10.04	225/496.04
65-40-1	919	590	1509	360	285	36.18	23.23	59.41	14.17	11.22	258/568.79
65-40	919	590	1509	360	285	36.18	23.23	59.41	14.17	11.22	258/568.79
65-50-2	1001	660	1661	400	310	39.41	25.98	65.39	15.75	12.20	319/703.27
65-50-1	1001	660	1661	400	310	39.41	25.98	65.39	15.75	12.20	319/703.27
65-50	1001	660	1661	400	310	39.41	25.98	65.39	15.75	12.20	320/705.48
65-60-2	1084	660	1744	400	310	42.68	25.98	68.66	15.75	12.20	325/716.50
65-60-1	1084	660	1744	400	310	42.68	25.98	68.66	15.75	12.20	349/769.41
65-60	1084	660	1744	400	310	42.68	25.98	68.66	15.75	12.20	349/769.41
65-70-2	1166	660	1826	400	310	45.90	25.98	71.89	15.75	12.20	353/778.23
65-70-1	1166	660	1826	400	310	45.90	25.98	71.89	15.75	12.20	353/778.23
65-70	1166	700	1866	460	340	45.90	27.56	73.46	18.11	13.39	420/925.94
65-80-2	1248	700	1948	460	340	49.13	27.56	76.69	18.11	13.39	424/934.76
65-80-1	1248	700	1948	460	340	49.13	27.56	76.69	18.11	13.39	424/934.76

Installation sketch

P
S
M
6
5

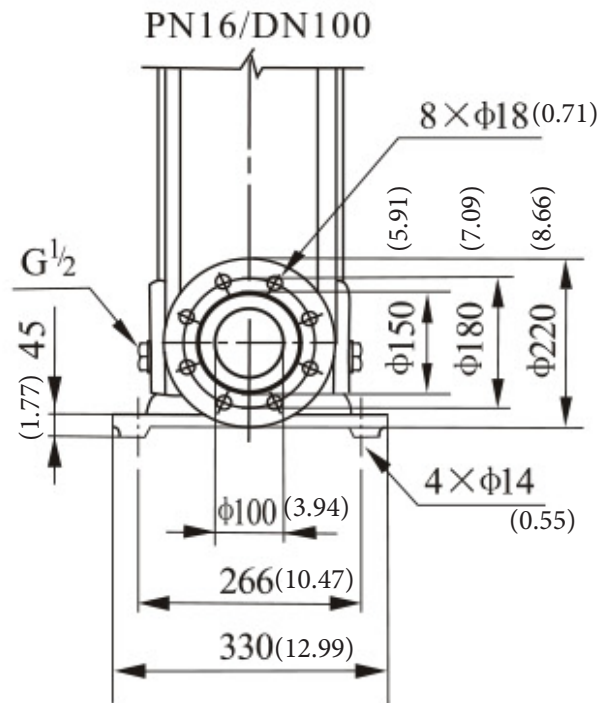
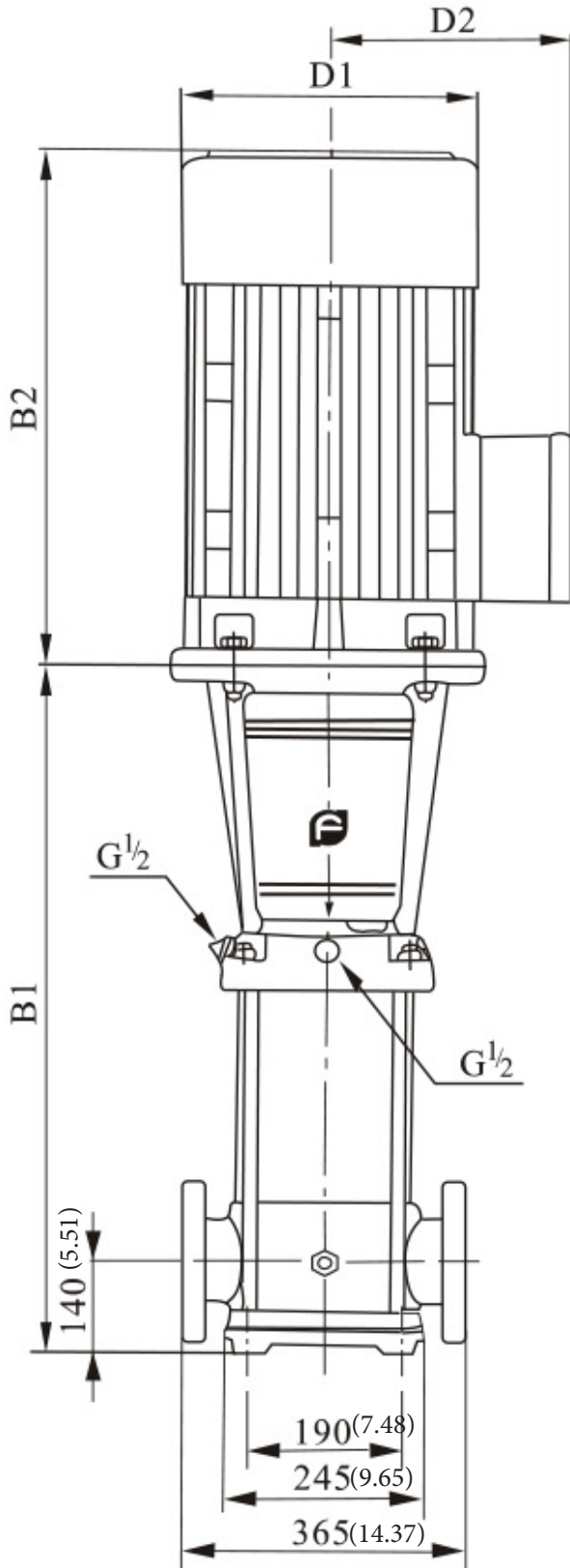



Performance curve ISO9906 Annex A 2900rpm

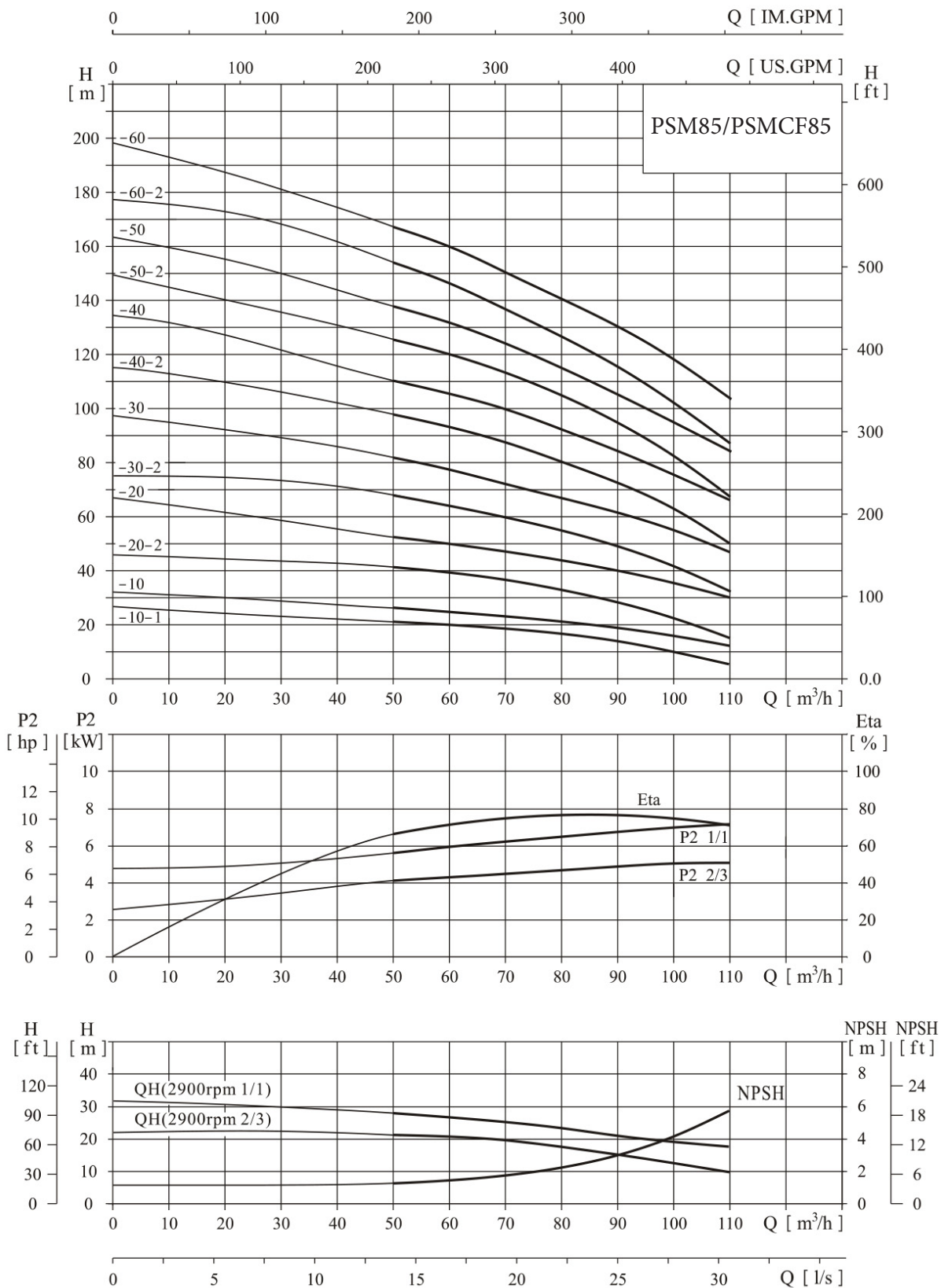



● Performance table

Model	Driving motor		Q (m ³ /h)	50	60	70	80	85	90	100	110	
	(kW)	(hp)										
P S M	85-10-1	5.5	7.5	H (m)	22	19	17	16	14	13	10	6
	85-10	7.5	10		25	24	22	21	20	19	16	12
	85-20-2	11	15		41	39	36	32	30	28	22	15
	85-20	15	20		53	50	47	44	41	40	36	30
	85-30-2	18.5	25		68	65	60	55	52	49	41	32
	85-30	22	30		81	77	72	67	64	62	55	48
	85-40-2	30	40		98	93	87	80	75	72	62	50
	85-40	30	40		110	105	100	92	86	84	76	66
	85-50-2	37	50		126	120	113	104	98	93	81	68
	85-50	37	50		139	131	124	115	110	106	94	83
	85-60-2	45	60		155	148	139	129	122	117	102	86
	85-60	45	60		168	160	150	141	134	130	117	103

PSM 85 MODEL	Size (mm)					Size (in)					Weight (kg/lbs)
	B1	B2	B1+B2	D1	D2	B1	B2	B1+B2	D1	D2	
85-10-1	571	430	1001	260	208	22.48	16.92	39.41	10.24	8.19	105/231.48
85-10	571	430	1001	260	208	22.48	16.92	39.41	10.24	8.19	110/242.50
85-20-2	773	490	1263	330	255	30.43	19.29	49.72	12.99	10.04	181/399.03
85-20	773	490	1263	330	255	30.43	19.29	49.72	12.99	10.04	192/423.28
85-30-2	865	550	1415	330	255	34.05	21.65	55.70	12.99	10.04	215/473.99
85-30	865	590	1455	360	285	34.05	23.23	57.28	14.17	11.22	252/555.57
85-40-2	957	660	1617	400	310	37.68	25.98	63.66	15.75	12.20	312/387.84
85-40	957	660	1617	400	310	37.68	25.98	63.66	15.75	12.20	312/387.84
85-50-2	1049	660	1709	400	310	41.30	25.98	67.28	15.75	12.20	336/740.75
85-50	1049	660	1709	400	310	41.30	25.98	67.28	15.75	12.20	336/740.75
65-60-2	1141	700	1841	460	340	44.92	27.56	72.48	18.11	13.39	407/897.28
65-60	1141	700	1841	460	340	44.92	27.56	72.48	18.11	13.39	407/897.28

P
S
M
8
5

Installation sketch

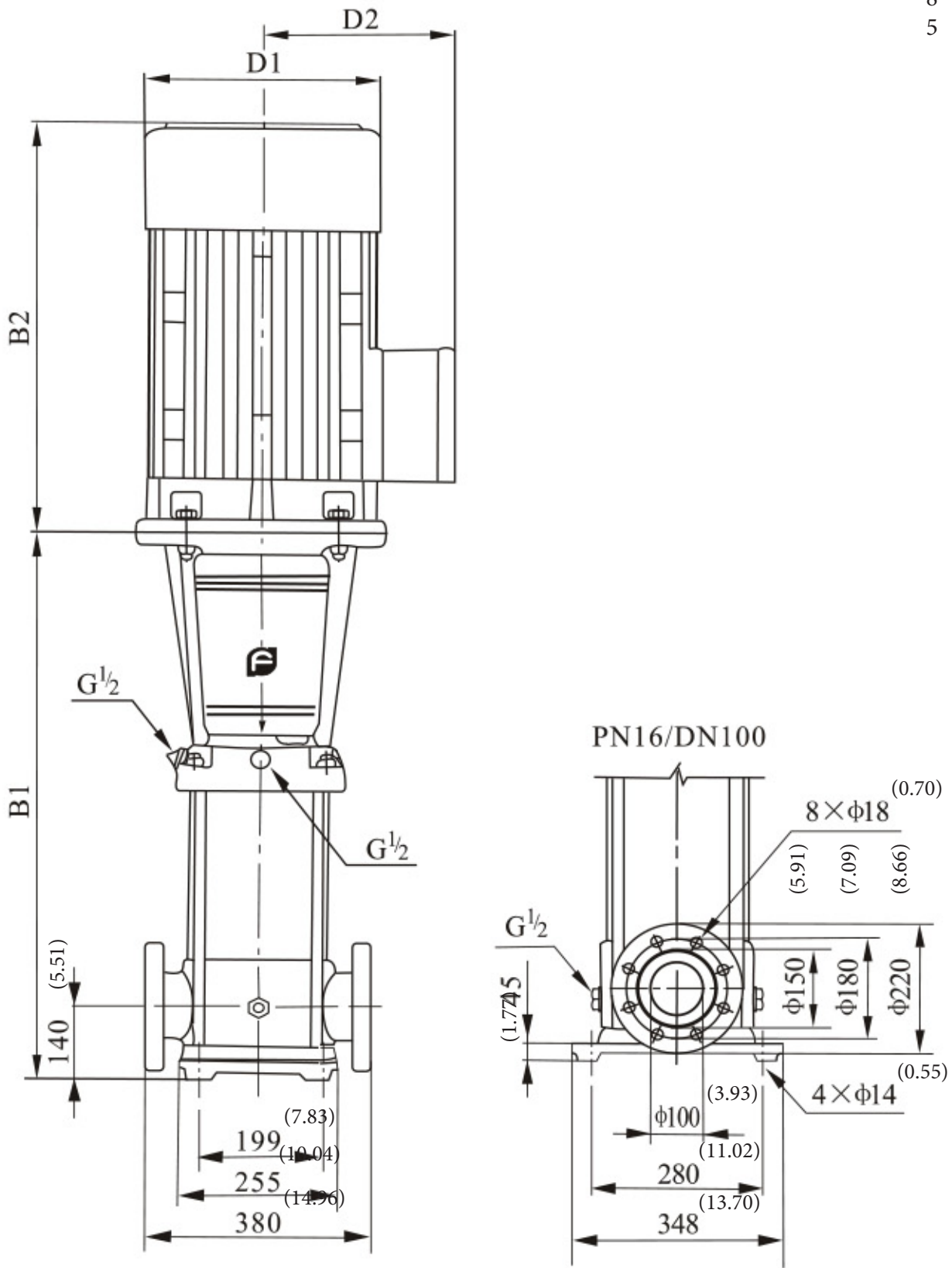



● Performance curve **ISO9906 Annex A 2950rpm**

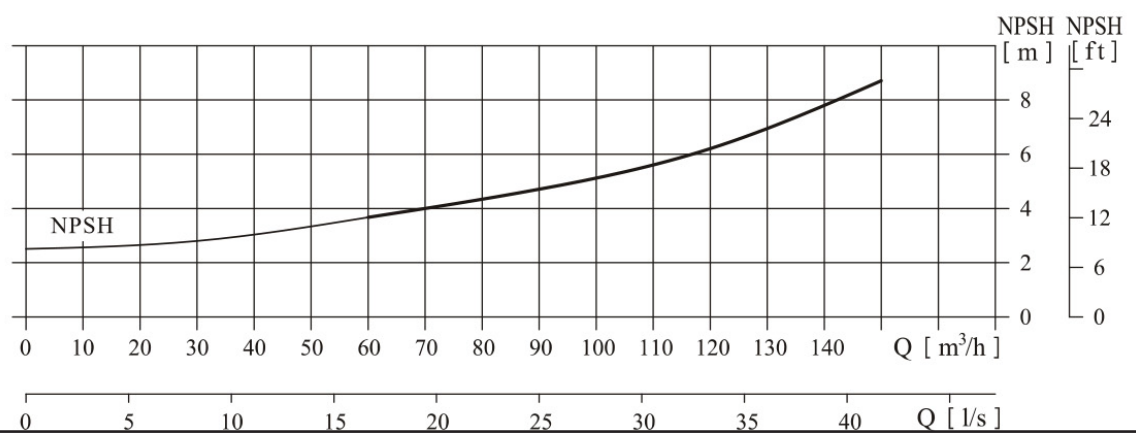
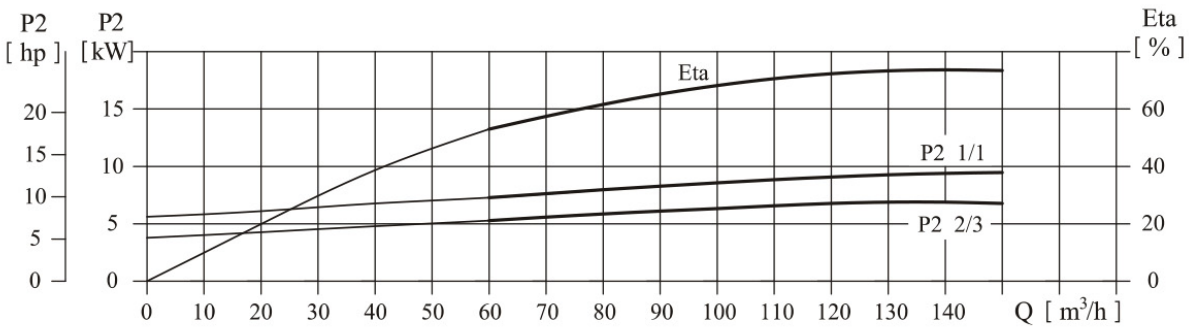
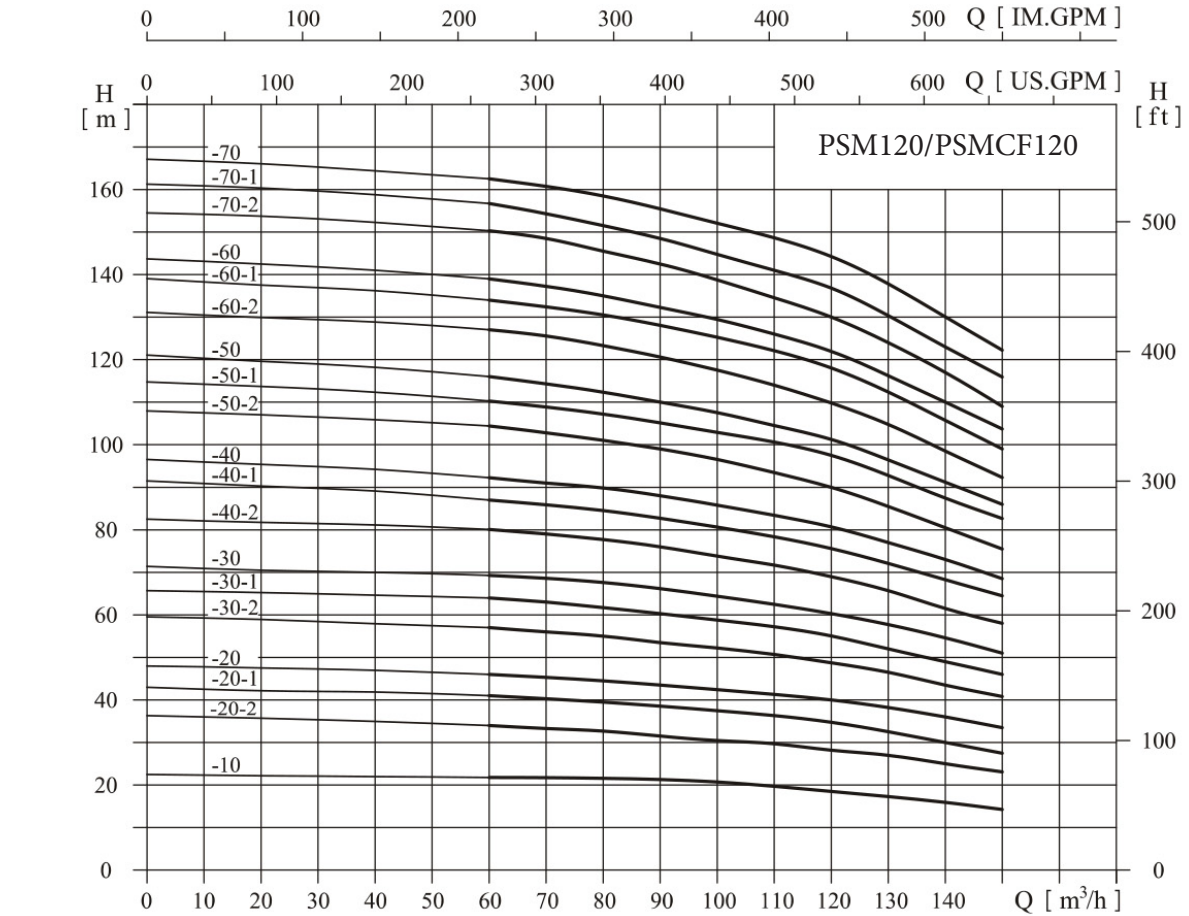

● Performance table

Model	Driving motor		Q (m ³ /h)	60	70	80	90	100	110	120	130	140	150
	(kW)	(hp)											
P S M	120-10	11	H (m)	22	21.8	21.6	21	20.5	19.5	18.5	17	16	15
	120-20-2	15		34	33.6	33	31	30.2	30	28.5	27	25	24
	120-20-1	18.5		41	40	39.5	38.5	37	36.5	34.5	32.5	30	27.5
	120-20	22		46	45	44.5	43.5	42.4	41	40	38	36	33.5
	120-30-2	30		57	56	55	53.5	52	51	49	46.5	43.5	41
	120-30-1	30		64	63	62	60	58.5	57.5	55.5	52	49	46
	120-30	30		69.5	68.5	67.5	66	64.4	62.5	61	57.5	54.5	51
	120-40-2	37		80.5	79	78	76	73.5	72	69	66	61.5	58
	120-40-1	37		87	86	84.5	82	80	78	76	72	68	64.5
	120-40	45		92.5	91	90	88	85.5	83	81	77	73	68.5
	120-50-2	45		104.5	103	101	99	96	93	90	85.5	80.5	75.5
	120-50-1	45		110.5	109	107.5	105	102	100	97	92	86.5	83
	120-50	55		115.5	114	113	110	107.5	104.5	101.5	96	91	86
	120-60-2	55		128	125.5	123	121	117.3	113.5	110	104.5	98.5	92.5
	120-60-1	55		134	132	130.5	127	124	121	118	111	105	100
	120-60	75		139	137	135	132	128.8	126	123	116	110	104
	120-70-2	75		151	148	145.5	143	138.6	134	130	123.5	116.5	109
120-70-1	75	156.5	154	152	148.5	144.5	141	137.5	130	123	116.5		
120-70	75	162.5	160.5	158.5	155	151	148	145	137	129	123		

PSM 120 MODEL	Size (mm)					Size (in)					Weight (kg/lbs)
	B1	B2	B1+B2	D1	D2	B1	B2	B1+B2	D1	D2	
120-10	840	490	1330	330	255	33.07	19.29	52.36	12.99	10.04	230/507.06
120-20-2	1000	490	1490	330	255	39.37	19.29	58.66	12.99	10.04	245/540.13
120-20-1	1000	550	1550	330	255	39.37	21.65	61.02	12.99	10.04	250/551.15
120-20	1000	590	1590	360	285	39.37	23.22	62.60	14.17	11.22	285/628.32
120-30-2	1160	660	1820	400	310	45.67	25.98	71.65	15.75	12.20	360/793.67
120-30-1	1160	660	1820	400	310	45.67	25.98	71.65	15.75	12.20	360/793.67
120-30	1160	660	1820	400	310	45.67	25.98	71.65	15.75	12.20	360/793.67
120-40-2	1320	660	1980	400	310	51.97	25.98	77.95	15.75	12.20	400/881.85
120-40-1	1320	660	1980	400	310	51.97	25.98	77.95	15.75	12.20	400/881.85
120-40	1320	700	2020	460	340	51.97	27.56	79.53	18.11	13.39	460/1014.13
120-50-2	1480	700	2180	460	340	58.26	27.56	85.82	18.11	13.39	470/1036.17
120-50-1	1480	700	2180	460	340	58.26	27.56	85.82	18.11	13.39	470/1036.17
120-50	1510	770	2280	540	370	59.45	30.32	89.76	21.26	14.57	575/1267.66
120-60-2	1670	770	2440	540	370	65.75	30.32	96.06	21.26	14.57	585/1289.7
120-60-1	1670	770	2440	540	370	65.75	30.32	96.06	21.26	14.57	585/1289.7
120-60	1670	845	2515	580	410	65.75	33.27	99.01	22.83	16.14	705/1554.26
120-70-2	1830	845	2675	580	410	72.04	33.27	105.32	22.83	16.14	715/1576.31
120-70-1	1830	845	2675	580	410	72.04	33.27	105.32	22.83	16.14	715/1576.31
120-70	1830	845	2675	580	410	72.04	33.27	105.32	22.83	16.14	715/1576.31

P
S
M
1
2
0

Installation sketch

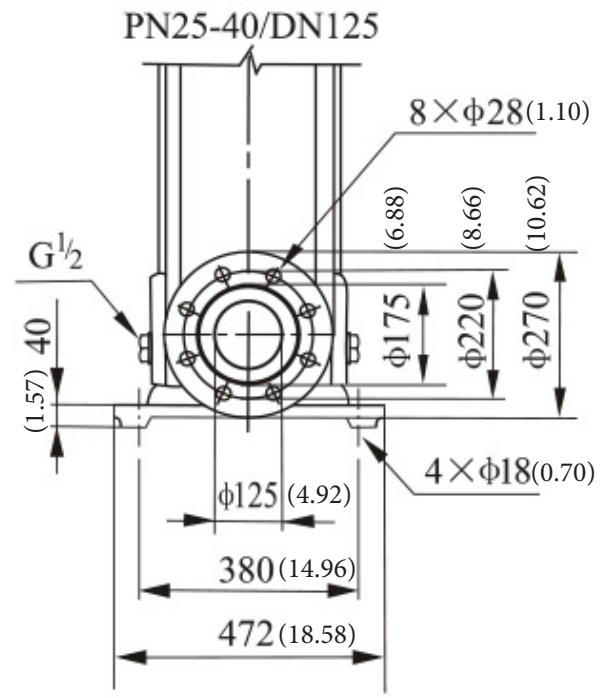
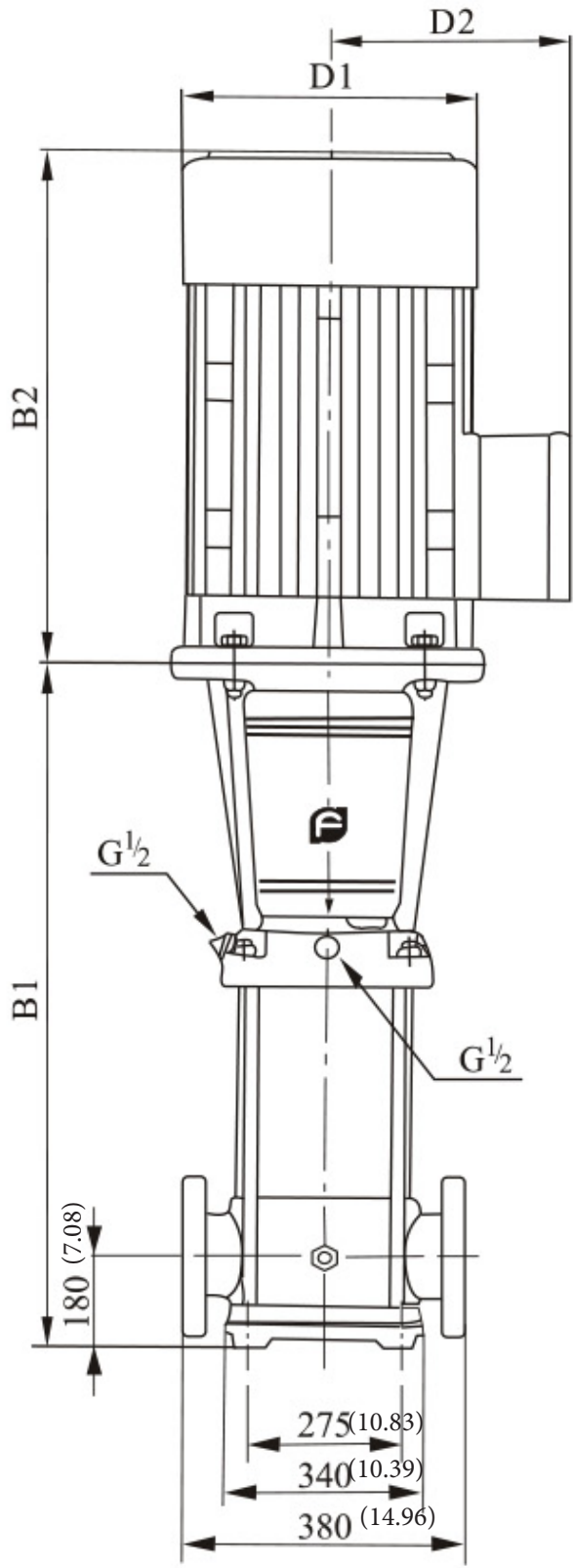

Performance curve

ISO9906 Annex A 2950rpm

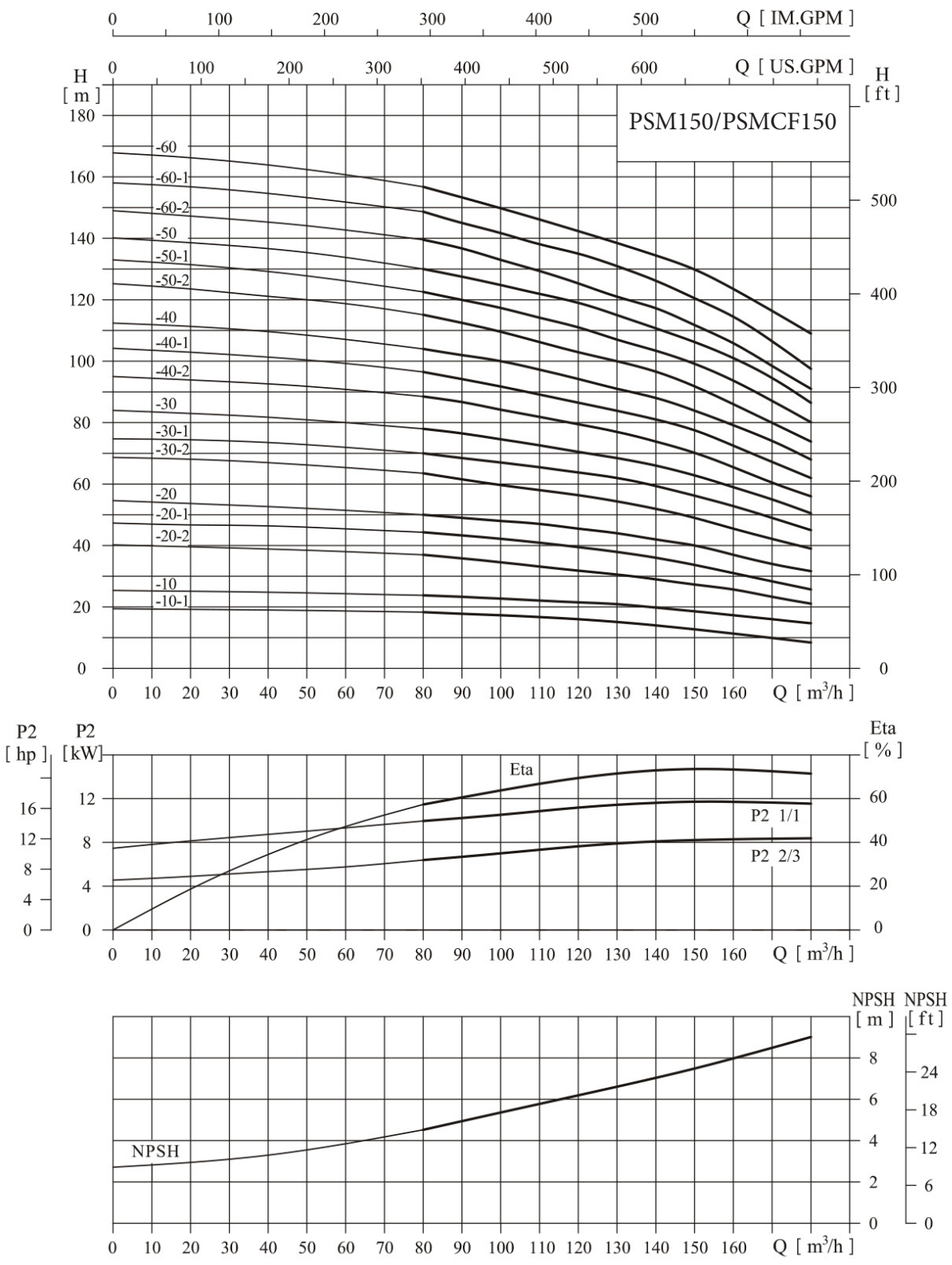

● Performance table

Model	Driving motor		Q (m ³ /h)	80	90	100	110	120	130	140	150	160	170	180	
	(kW)	(hp)													
P S M	150-10-1	11	15	H (m)	18.3	17.8	17.3	17	16	15	14	12.5	11	10	8.5
	150-10	15	20		24	23	22.5	22	21.5	20.5	20	18.5	17	16	15
	150-20-2	18.5	25		37	35.5	34	33	32	31	29	27.5	26	23	21
	150-20-1	22	30		44.3	43	42	40	39	38.5	37.5	35	33	30	27
	150-20	30	40		50	49	48	47	45.5	44	42	40	37	34	32
	150-30-2	30	40		63.5	61	59	57.5	56	54.5	53	49	45.5	42	39
	150-30-1	37	50		70	68	67	65	63	62	60	56	53	49	45
	150-30	37	50		78	76.5	75	73	70.5	68	66	63	59	55	50.5
	150-40-2	45	60		89	87	84	81.5	79	77	74.5	70.5	65.5	60	56
	150-40-1	45	60		96.5	94	91.5	89	86.5	84	81.5	77	72.5	67	62
	150-40	55	75		104	102	100	97	95	91	88	84	79.5	74	68
	150-50-2	55	75		115.5	112	109	106	102.5	100	97	92	86	79	73.5
	150-50-1	75	100		122.5	119.5	117	113.5	111.5	107.5	104.5	99	93.5	87	80
	150-50	75	100		130	127.5	125	121	119	115	111.5	106.5	101	94.5	86.5
	150-60-2	75	100		140	137	133	130	126	121	118	112	106	98	91
	150-60-1	75	100		148.5	145	141.7	137.5	135	131	127	120.5	114.5	106.5	97.5
	150-60	75	100		157	153	149	145	142	139.5	137	130	123.5	116	109

PSM 150 MODEL	Size (mm)					Size (in)					Weight (kg)
	B1	B2	B1+B2	D1	D2	B1	B2	B1+B2	D1	D2	
150-10-1	840	490	1330	330	255	33.07	19.29	52.36	12.99	10.04	230/507.06
150-10	840	490	1330	330	255	33.07	19.29	52.36	12.99	10.04	235/518.09
150-20-2	1000	550	1550	330	255	39.37	21.65	61.02	12.99	10.04	250/551.16
150-20-1	1000	590	1590	360	285	39.37	23.22	62.60	14.17	11.22	295/650.36
150-20	1000	660	1660	400	310	39.37	25.98	65.35	15.75	12.20	350/771.62
150-30-2	1160	660	1820	400	310	45.67	25.98	71.65	15.75	12.20	360/793.66
150-30-1	1160	660	1820	400	310	45.67	25.98	71.65	15.75	12.20	360/793.66
150-30	1160	660	1820	400	310	45.67	25.98	71.65	15.75	12.20	385/848.78
150-40-2	1320	700	2020	460	340	51.97	27.56	79.53	18.11	13.39	460/1014.13
150-40-1	1320	700	2020	460	340	51.97	27.56	79.53	18.11	13.39	460/1014.13
150-40	1350	770	2120	540	370	53.14	30.32	83.46	21.26	14.57	560/1234.59
150-50-2	1510	770	2180	540	370	59.44	30.32	85.83	21.26	14.57	570/1256.63
150-50-1	1510	845	2355	580	410	59.44	33.27	92.72	22.83	16.14	690/1521.19
150-50	1510	845	2355	580	410	59.44	33.27	92.72	22.83	16.14	690/1521.19
150-60-2	1670	845	2515	580	410	65.75	33.27	99.01	22.83	16.14	700/ 1543.24
150-60-1	1670	845	2515	580	410	65.75	33.27	99.01	22.83	16.14	700/ 1543.24
150-60	1670	845	2515	580	410	65.75	33.27	99.01	22.83	16.14	700/ 1543.24

P
S
M
1
5
0

Installation sketch

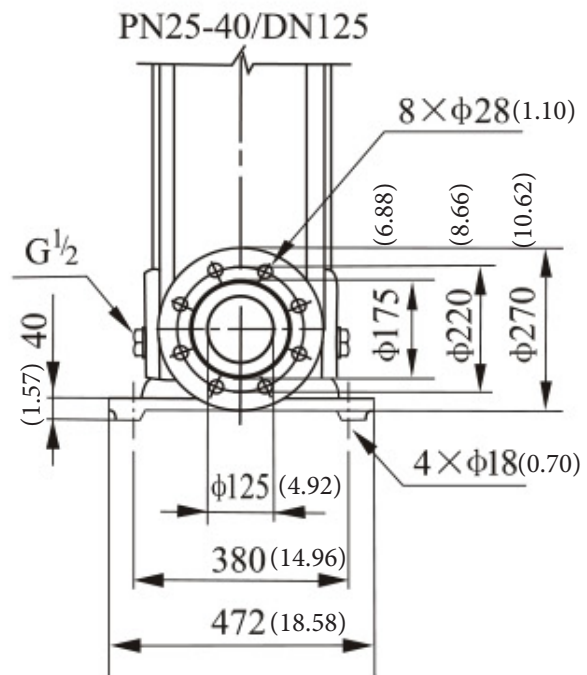
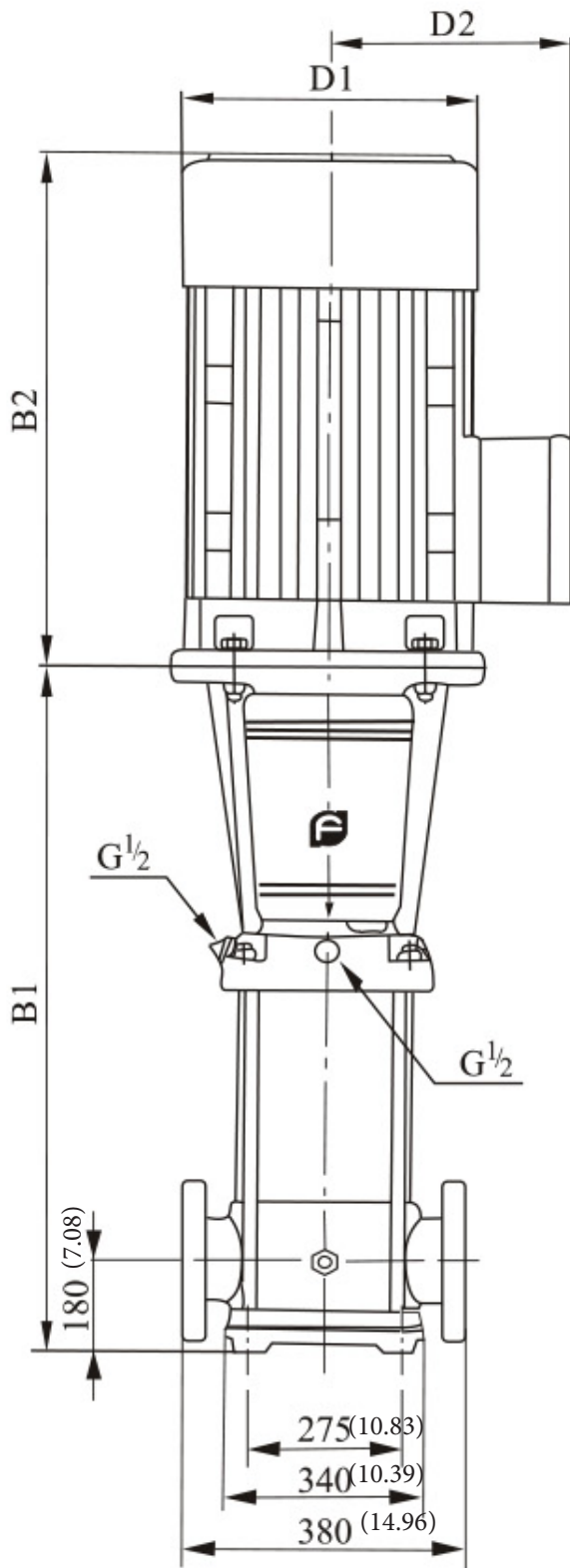



● Performance curve **ISO9906 Annex A 2950rpm**

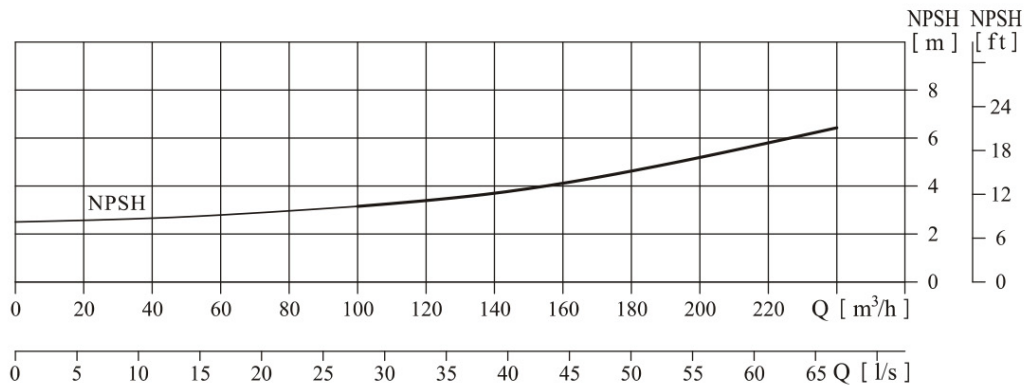
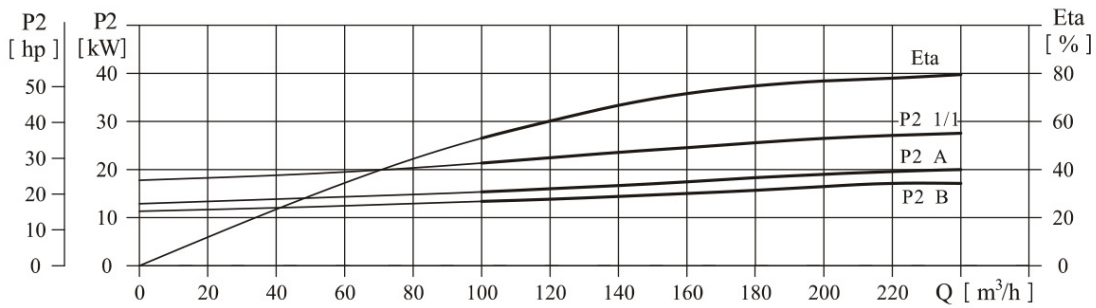
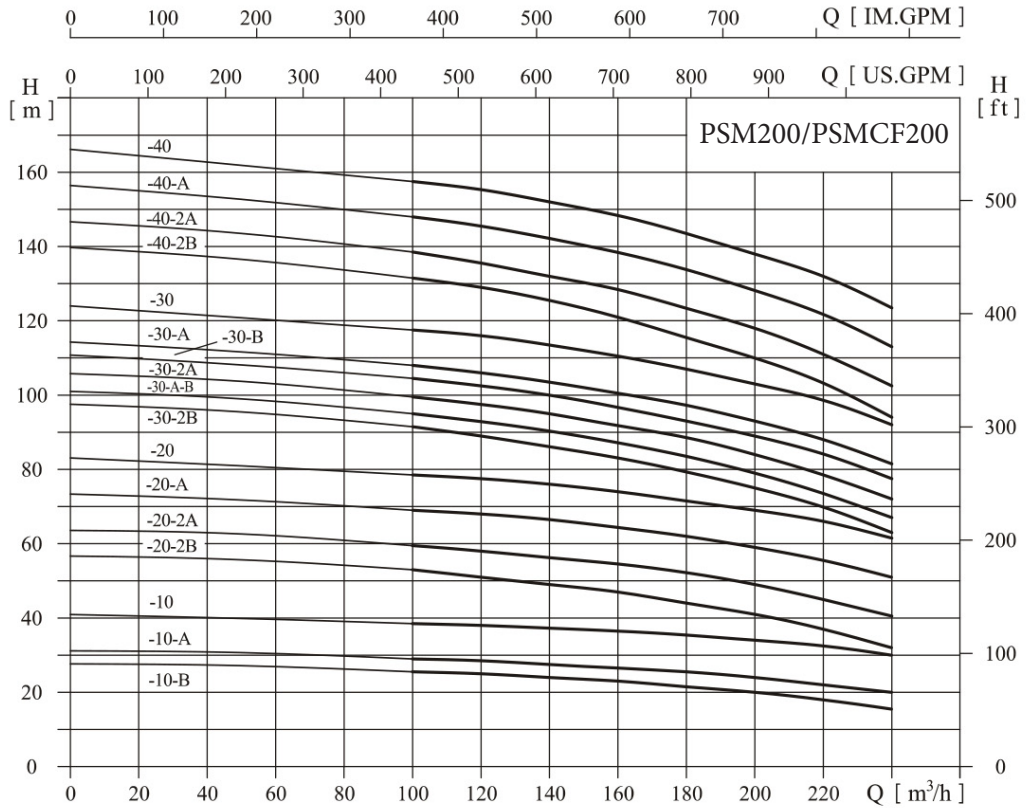

Performance table

Model	Driving motor		Q (m ³ /h)	100	120	140	160	180	200	220	240
	(kW)	(hp)									
P S M	200-10-B	18.5	25	25.5	25	24	23	21.5	20	18	15.5
	200-10-A	22	30	29	28.5	27.5	26.5	25.5	24	22	20
	200-10	30	40	38.5	38	37.5	36.5	35	34	32.5	30
	200-20-2B	37	50	53	51	49	47	44	41	37	32
	200-20-2A	45	60	59.5	58	56	54	52.5	49	44.5	40.5
	200-20-A	55	75	69	68	66	64	62	59	55.5	51
	200-20	55	75	78.5	77.5	76	74	71.5	69	66	61.5
	200-30-2B	75	100	91.5	89	86.5	83.5	79	75	70	63
	200-30-A-B	75	100	95	93	90	87	83.5	79	73.5	67
	200-30-2A	75	100	99.5	97.5	94.5	91.5	89	84	78.5	72
	200-30-B	75	100	104.5	102.5	100	97	93	89	84.5	77.5
	200-30-A	75	100	108	106	103.5	100.5	97.5	93	88	81.5
	200-30	90	120	117.5	116	113.5	110.5	107	103	99	92
	200-40-2B	90	120	131.5	129	125.5	121	115.5	110	103.5	94
	200-40-2A	110	150	138.5	136	132	128	124	118	111	102.5
	200-40-A	110	150	148	145.5	142.5	138	134	128	122	113
	200-40	110	150	157.5	155.5	152.5	148	143.5	138	132.5	123.5

PSM 200 MODEL	Size (mm)					Size (in)					Weight (kg)
	B1	B2	B1+B2	D1	D2	B1	B2	B1+B2	D1	D2	
200-10-B	907	550	1457	330	255	35.71	21.65	57.36	12.99	10.03	311/685.63
200-10-A	907	590	1497	360	285	35.71	23.23	58.94	14.17	11.22	347/765
200-10	907	660	1567	400	310	35.71	25.98	61.69	15.75	12.20	403/888.46
200-20-2B	1101	660	1761	400	310	43.34	25.98	69.33	15.75	12.20	447/985.46
200-20-2A	1101	700	1801	460	340	43.34	27.56	70.90	18.11	13.39	504/1111.13
200-20-A	1131	770	1901	540	370	44.53	30.31	74.84	21.26	14.56	595/1311.75
200-20	1131	770	1901	540	370	44.53	30.31	74.84	21.26	14.56	595/1311.75
200-30-2B	1325	845	2170	580	410	52.17	33.27	85.43	22.83	16.14	748/1649.06
200-30-A-B	1325	845	2170	580	410	52.17	33.27	85.43	22.83	16.14	748/1649.06
200-30-2A	1325	845	2170	580	410	52.17	33.27	85.43	22.83	16.14	748/1649.06
200-30-B	1325	845	2170	580	410	52.17	33.27	85.43	22.83	16.14	748/1649.06
200-30-A	1325	845	2170	580	410	52.17	33.27	85.43	22.83	16.14	748/1649.06
200-30	1325	895	2220	580	410	52.17	35.23	87.40	22.83	16.14	817/1801.18
200-40-2B	1519	895	2414	580	410	59.80	35.23	95.03	22.83	16.14	830/1829.84
200-40-2A	1519	1140	2659	645	550	59.80	44.88	104.69	25.39	21.65	1180/2601.45
200-40-A	1519	1140	2659	645	550	59.80	44.88	104.69	25.39	21.65	1180/2601.45
200-40	1519	1140	2659	645	550	59.80	44.88	104.69	25.39	21.65	1180/2601.45

Installation sketch

P
S
M
2
0
0
0

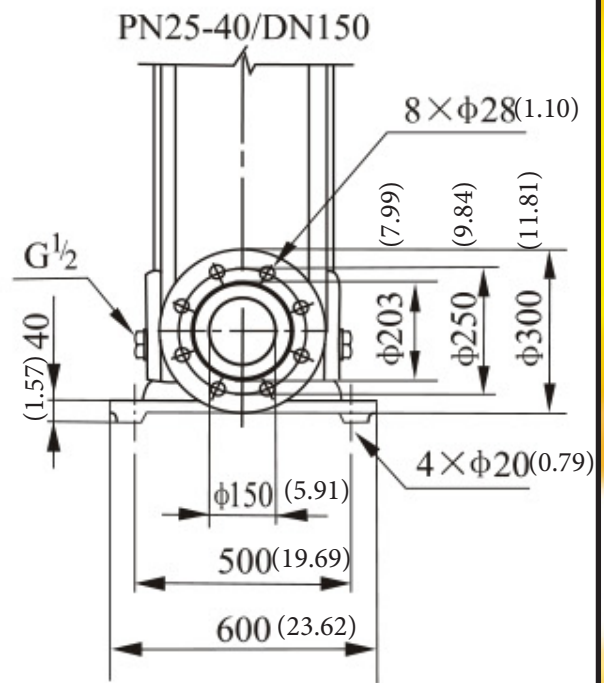
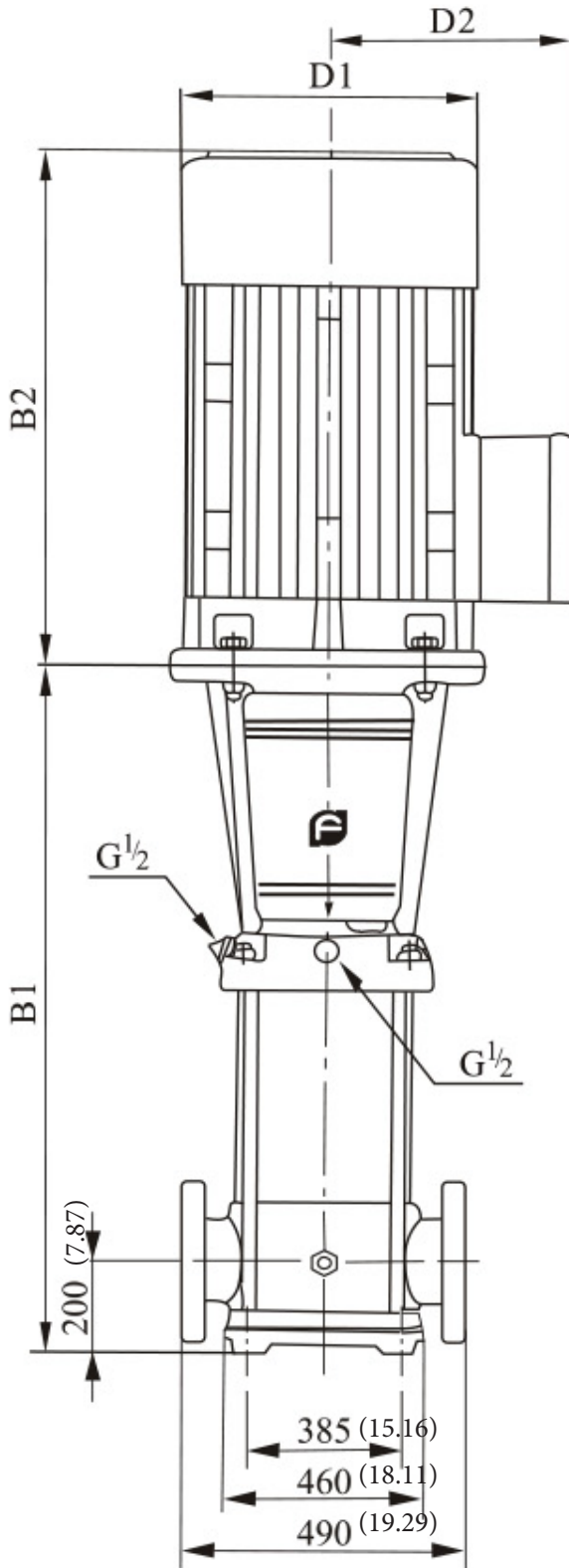

We are proud supplier for the following completed and on going projects :



Bethware Elementary High School
115 Bethware Dr, Kings Mountain, NC, United States



Old Montreal College
255 Ontario East
Montreal, Quebec, CA



Ratiopharm Inc.
17800 Rue Lapointe,
Mirabel, QC, CA



Campus 99
5151 Côte Ste-Catherine
Montréal, QC, CA

Sales and Service:

Quebec, Canada
Tel. : (450) 621-2995
Fax : (450) 621-4995

Lake Worth
Florida, USA
33467-5749

Toronto, Canada
Tel. : +1 (647) 544-2995

www.flofab.com

SERVICE 24/7 : parts@flofab.com

