



# Jockey Fire Pump

## PSM/PSMCF Series

### 60HZ



**PSM**



**PSMCF**



**90% FINISH  
DOCUMENT**

[www.flofab.com](http://www.flofab.com)

001-cat-2016-psmf60





# TABLE OF CONTENTS

## GENERAL DATA

<b>PERFORMANCE SCOPE &amp; PRODUCT RANGE.....</b>	<b>3</b>
<b>PRODUCT INFORMATIONS.....</b>	<b>4</b>
<b>PRODUCT SPECIFICATIONS.....</b>	<b>5</b>
<b>CURVE ILLUSTRATION.....</b>	<b>6</b>
<b>MINIMUM INLET PRESSURE/OPERATION IN PARALLEL.....</b>	<b>7</b>
<b>SECTION DRAWING/MATERIAL.....</b>	<b>8-11</b>
<b>PERFORMANCE TABLE, INSTALLATION SKETCH, SIZE AND WEIGHT.....</b>	<b>12</b>

## TECHNICAL DATA

<b>PERFORMANCE CURVE.....</b>	<b>13-41</b>
<b>PERFORMANCE DATA.....</b>	<b>13-41</b>
<b>INSTALLATION SKETCH.....</b>	<b>13-41</b>
<b>SIZE AND WEIGHT.....</b>	<b>13-41</b>

# HISTORY

Flo Fab was established in 1981 by Denis Gauvreau who created and developed the products line and constantly being perfected by Marc Gauvreau, as well as by a team of professional engineers and designers. It's a combination of existing designs from several renowned products and the innovative ideas of a new generation professionals.

Through the years, Flo Fab has acquired several companies and service entities including : AQUA-PROFAB (ASME Tanks manufacturer), MÉNARD, LÉONARD ÉLECTRIQUE, PMA. , Furthermore Flo Fab purchased equipment, fabrication designs and patterns from IDEALCO, a manufacturer of shell and tube type heat exchangers.

The after sales services, sales, engineering, R&D, production, quality control, accounting and administration departments of all the above companies share the same location.

In December 2014, Marc Gauvreau, son of the founder, acquired all shares of The company. Flo Fab and is constantly investing in new state of the art innovations new product like the XRI series and Prefab Skid for Hydronic Heating 8 cooling system, pumping systems. This has allowed Flo Fab to retain competent and experienced staff of professionals with varied and specialized abilities that constantly work on improving our existing products and add new engineered solutions that exceeding customer's expectations .

Flo Fab has grown quite rapidly and now proudly offers of a wide range of products available directly from one manufacturer. This includes pumps & pump packages, tanks, heat exchangers & hydronic accessories. This allows each project stakeholders to enjoy economical savings, peace of mind, best value for their investment and optimized total cost of ownership.



# FLO FAB'S SERIES PSM 60HZ - TECHNICAL DATA

## Performance Scope & Product Range

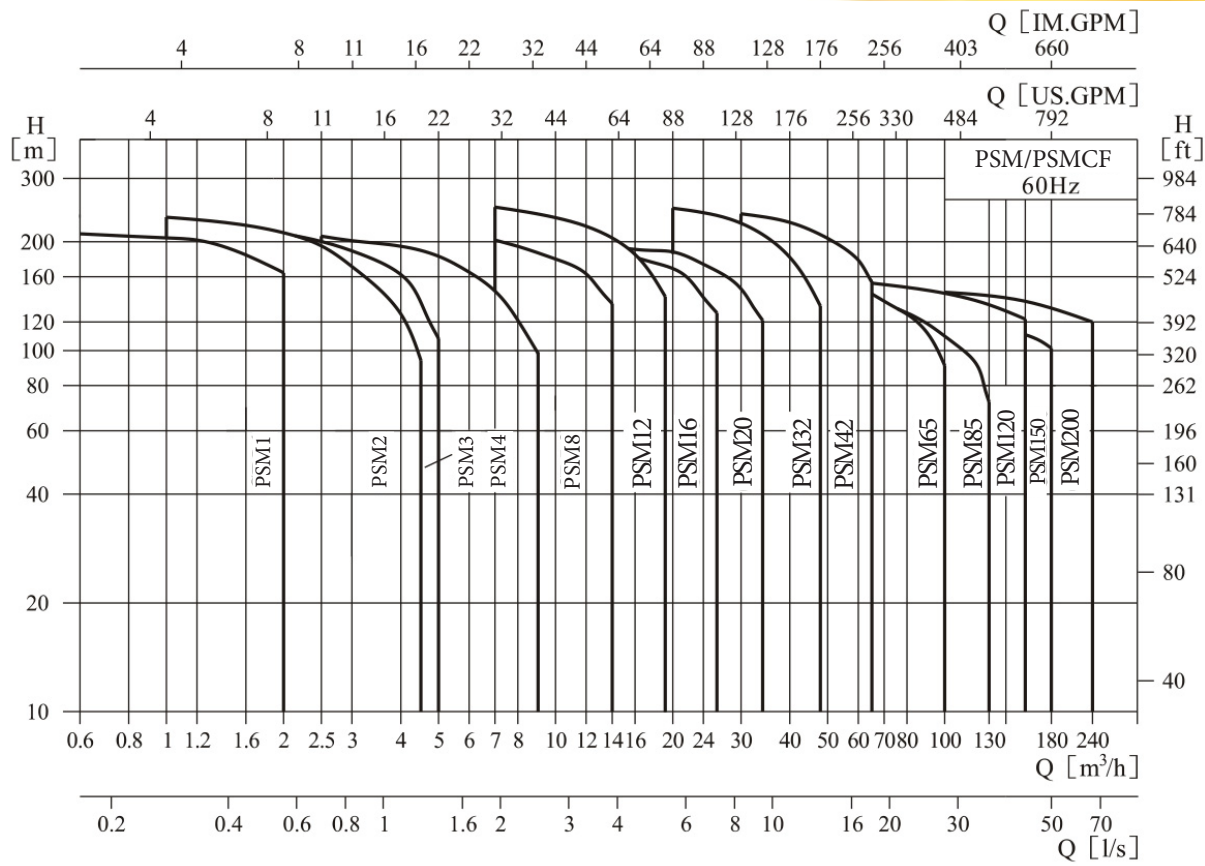

Description	PSM1	PSM2	PSM3	PSM4	PSM8	PSM12	PSM16	PSM20	PSM32	PSM42	PSM65	PSM85	PSM120	PSM150	PSM200
Rated flow [m³/h]	1	2	3	4	8	12	16	20	32	42	65	85	120	150	200
Rated flow [l/s]	0.28	0.56	0.83	1.1	2.2	3.3	4.4	5.6	8.9	11.7	18	24	33	41.6	55.6
Flow range [m³/h]	0.6-2	1-4.5	1.5-5	2.5-8	7-14	7-19	10-26	12-34	20-48	30-65	40-100	60-130	60-160	80-180	100-240
Flow range [l/s]	0.17-0.56	0.28-1.25	0.42-1.4	0.7-2.2	1.9-3.9	1.9-5.3	2.8-7.2	3.3-9.4	5.5-13.3	8.3-18	11.1-27.7	16.7-36.1	16.7-44.4	22-50	27.8-66.7
Max.pressure [bar]	22	23.5	23	21	20	25	20	20	25	26	18	15	15	14	15
Motor power [kW]	0.37-3	0.55-4	0.37-4	0.75-5.5	0.75-11	1.1-15	2.2-18.5	2.2-18.5	3-30	5.5-45	7.5-45	11-45	18.5-75	15-75	30-110
Temperature range [°C]	-15~+120														
Max. efficiency [%]	44	46	54	57	62	63	66	69	73	75	76	77	74	73	78
Type															
CDL	●	●	●	●	●	●	●	●	●	●	●	●	●	●	●
CDLF	●	●	●	●	●	●	●	●	●	●	●	●	●	●	●
CDL Pipe connection															
DIN Flange	DN25	DN25	DN25	DN32	DN40	DN50	DN50	DN50	DN65	DN80	DN100	DN100	DN125	DN125	DN150
Oval Flange	G1	G1	G1	G1¼	G1½										
CDLF Pipe connection															
DIN Flange	DN25	DN25	DN25	DN32	DN40	DN50	DN50	DN50	DN65	DN80	DN100	DN100	DN125	DN125	DN150
Cutting ferrule joint	●	●	●	●	●	●	●	●							
Pipe thread	●	●	●	●	●	●	●	●							

# FLO FAB'S SERIES PSM 60HZ - TECHNICAL DATA

## ● Pump

PSM/PSMCF is a kind of vertical non-self priming multistage centrifugal pump, which is driven by a standard electric motor. The motor output shaft directly connects with the pump shaft through a coupling. The pressure-resistant cylinder and flow passage components are fixed between pump head and inlet & outlet section with stay bolts. The inlet and outlet are located at the pump bottom at the same plane. This kind of pump can be equipped with an intelligent protector to effectively prevent it from dry-running, out-of-phase and overload.

## ● Motor

- Full-enclosed air-blast two-pole standard motor
- Protection class: IP55
- Insulation class: F
- Standard voltage: 60Hz: 3 × 200-230 / 346-400V  
3 × 220-255 / 380-440V  
3 × 220-277 / 380-480V

## ● Definition of Model

PSM/PSMCF 1,2,3,4,8,12,16 and 20

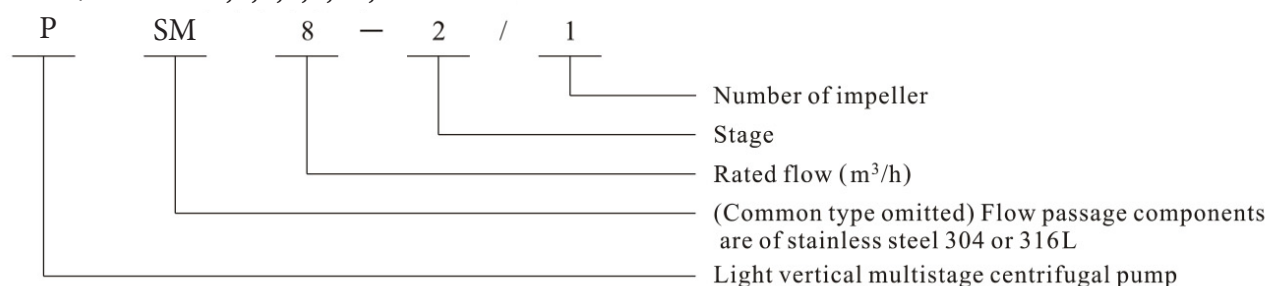

PSM/PSMCF 32,42,65,85,120,150 and 200

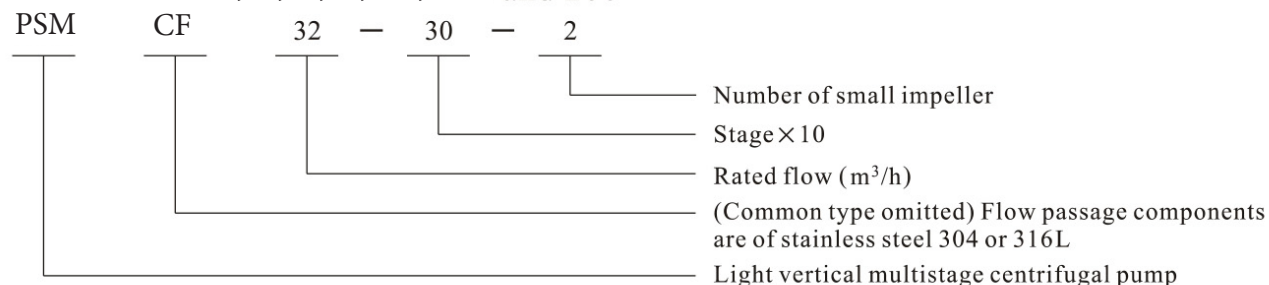

## ● Application

PSM/PSMCF is a kind of multifunctional products. It can be used to convey various medium from tap water to industrial liquid at different temperature and with different flow rate and pressure. CDL type is applicable to conveying non-corrosive liquid while PSMCF is suitable for slightly corrosive liquid.

- Water supply: Water filter and transport in Waterworks, boosting of main pipeline, boosting in high-rise buildings.
- Industrial boosting: Process flow water system, cleaning system, high-pressure washing system, fire fighting system.
- Industrial liquid conveying: Cooling and air-conditioning system, boiler water supply and condensing system, machine-associated purpose, acids and alkali.
- Water treatment: Ultrafiltration system, reverse osmosis system, distillation system, separator, swimming pool.
- Irrigation: Farmland irrigation, spray irrigation, drip-irrigation.

## ● Operation conditions

- Thin, clean, non-flammable and non-explosive liquid containing no solid granules and fibers.
- Liquid temperature:  
Normal temperature type: -15°C ~ +70°C,  
Hot water type: -15°C ~ +120°C
- Ambient temperature: up to +40°C
- Altitude: up to 1000m

# FLO FAB'S SERIES PSM 60HZ - TECHNICAL DATA

## PSM/PSMCF

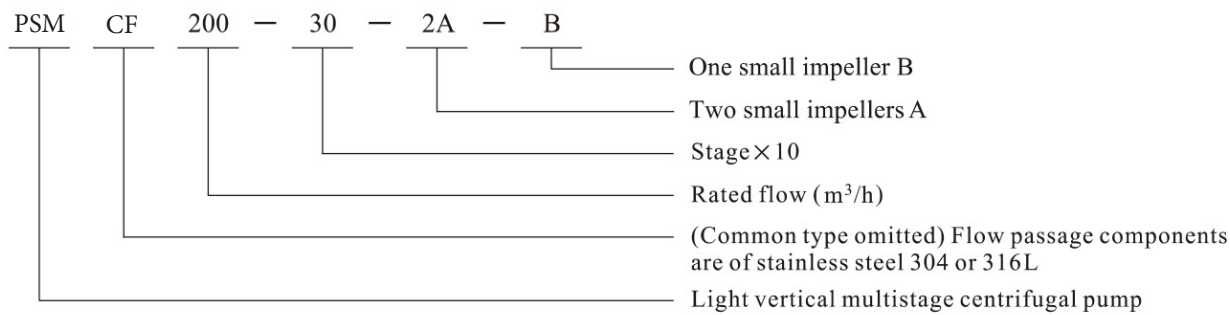

### ● Max working pressure

Model	Curve number
PSM 1,2,3,4 Flange	2
PSM 1,2,3,4 Oval Flange	1
PSMCF 1,2,3,4	2
PSM 8,12,16,20 Flange	3
PSM 8 Oval Flange	1
PSMCF 8,12,16,20	3
PSM, PSMCF 32	
32-10-1~32-50-2	1
32-50~32-90-2	4
32-90~32-100-2	5
PSM, PSMCF 42	
42-10-1~42-30	1
42-40-2~42-60	4
42-70-2~42-70	5
PSM, PSMCF 65	
65-10-1~65-30	1
65-40-2~65-50-2	4
PSM, PSMCF 85	
85-10-1~85-30	1
85-40-2	4
PSM, PSMCF 120,150,200	6

The following figure shows the limitation of pressure and temperature, which shall be in the scope as shown in the figure.

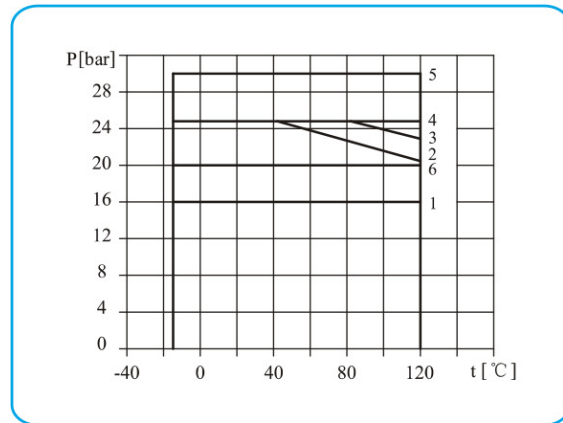

### ● Max. Ambient temperature

When the pump operates under ambient temperature higher than 40°C or under altitude higher than 1000m, because of low air density and poor cooling effects, the motor output power P2 will be decreased to certain extent. If the pump is operated under the above-said conditions, it should be equipped with motor of higher power.

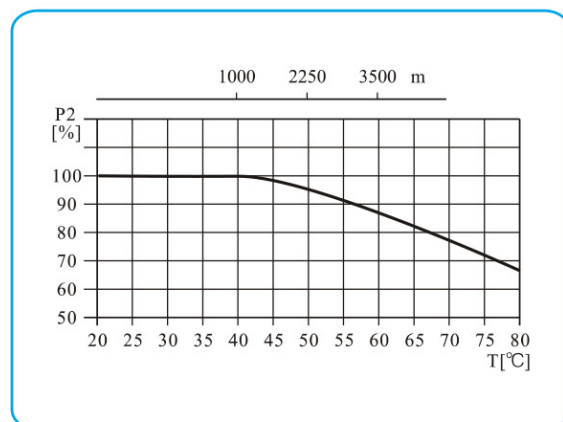

# FLO FAB'S SERIES PSM 60HZ - TECHNICAL DATA

## Curve illustration

Stage  
First number:  
Stage × 10  
Second number:  
Number of small impeller

The power curve presents the input power of each stage, which is divided into integrate impeller t-type(1/1) and the type with small impeller (2/3)

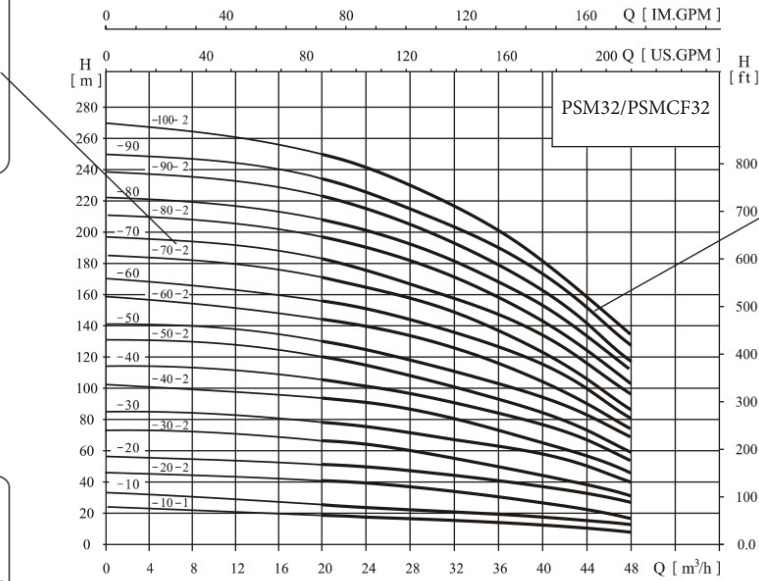

Pump Q-H curve, the thickened line presents recommended performance region

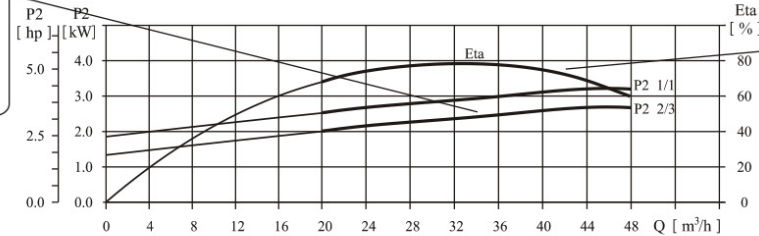

Eta curve presents efficiency of the pump, For the pump equipped with small impeller, its efficiency will be 2% lower than that shown by the curve.

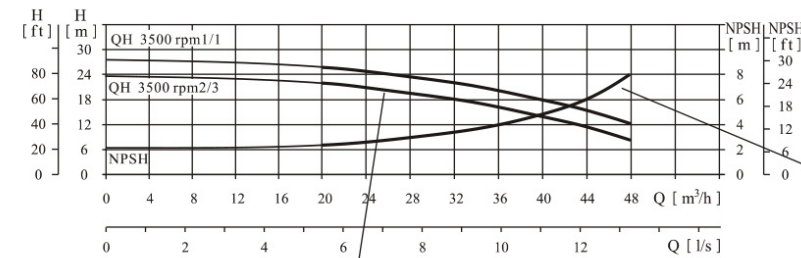

NPSH curve expresses the average value of all curves of this series. A safety margin of 0.5m shall be taken into consideration when making selection.

The Q-H curve of each stage, presenting integrate impeller type(1/1)and the type equipped with small impeller(2/3).

## Performance curve

Following conditions are suitable for the performance curves shown below:

- 1、 All curves are based on the measured values of 60Hz: constant motor speed 3500 rpm or 3540rpm.
- 2、 Curve tolerance in conformity with ISO9906 Annex A.
- 3、 Measurement is done with 20°C air-free water, kinematic viscosity of 1mm<sup>2</sup>/sec.

matic viscosity of 1mm<sup>2</sup>/sec.

- 4、 The operation of pump shall refer to the performance region indicated by the thickened curve to prevent overheating due to too small flow rate or overload of motor due to too large flow rate.

# FLO FAB'S SERIES PSM 60HZ - TECHNICAL DATA

## ● Minimum inlet pressure NPSH

In case that the pressure in pump is lower than the steam pressure used to convey liquid, the cavitations will occur. To avoid cavitations, a minimum pressure at the inlet side of the pump shall be guaranteed. The maximum suction stroke can be calculated with following formula:

$$H = P_b \times 10.2 - NPSH - H_f - H_v - H_s$$

$P_b$  = atmosphere pressure [bar]

(can be set as 1bar)

In a closed system,  $P_b$  means system pressure [bar]

NPSH = Net positive suction head [m]

(It can be read out from the point of possible max.

flow rate shown on NPSH curve)

$H_f$  = Pipeline loss at the inlet [m]

$H_v$  = Steam pressure [m]

$H_s$  = Safety margin = Minimum 0.5m delivery head

If the calculated result  $H$  is positive, the pump may run under the max. Suction stroke  $H$ .

In case the calculated result  $H$  is negative, a delivery head of min. Inlet pressure is necessary.

## ● Operation in parallel

Connecting several pumps in parallel running will benefit much more than running a single large pump.

- Applicable to different working states necessary in a variable flow system.

- Increasing the possibility of water supply when the pump is in failure. Because in case of pump failure, only part of the system flow is effected.

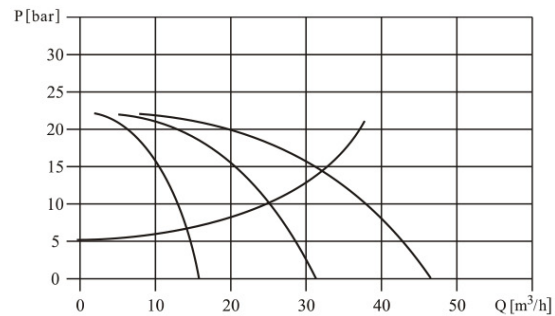

Two pumps or more can be connected in parallel running if necessary.

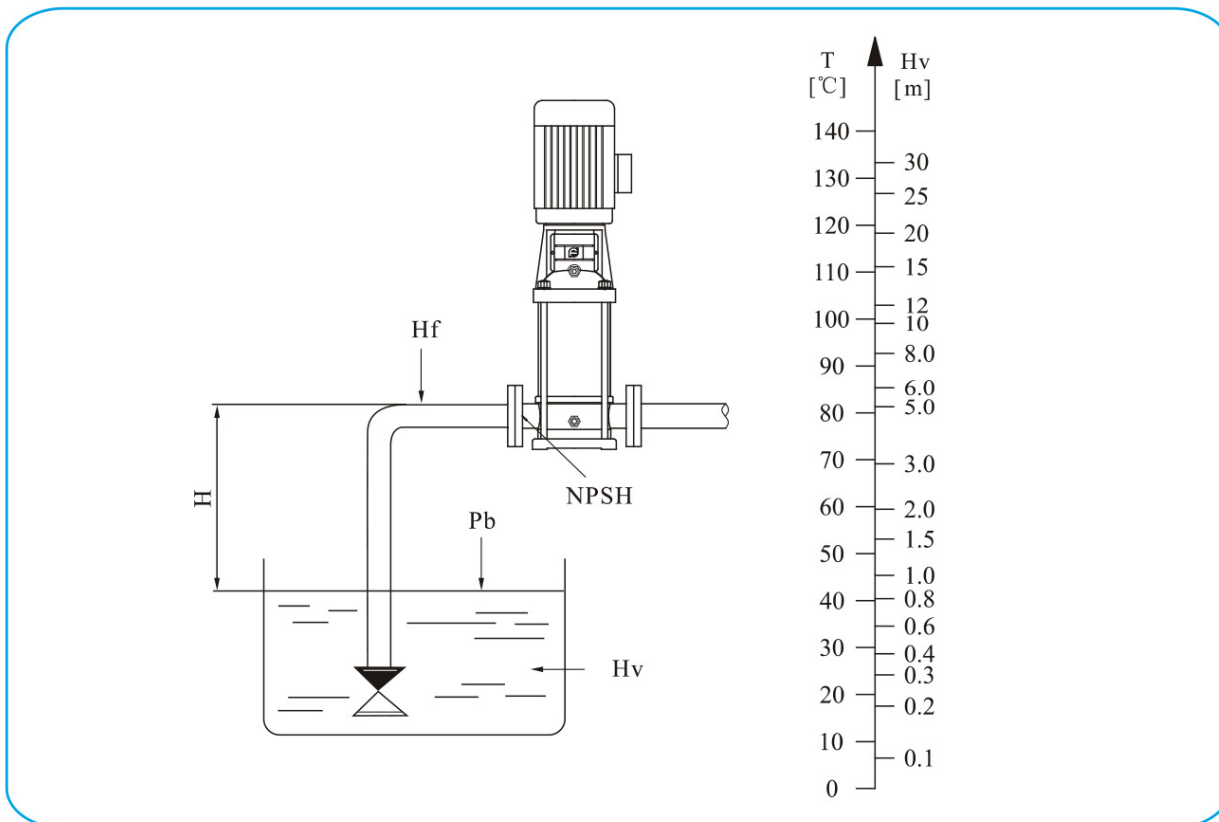

Check and ensure that the pump is not at cavitations state.

# FLO FAB'S SERIES PSM 60HZ - TECHNICAL DATA

## Section drawing PSM/PSMCF1,2,3,4

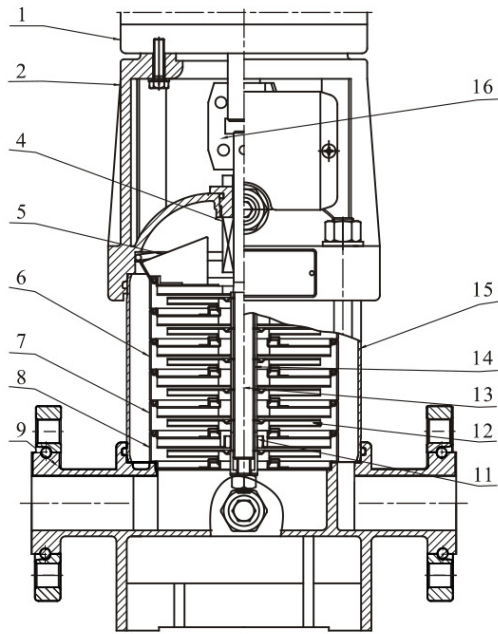

PSM

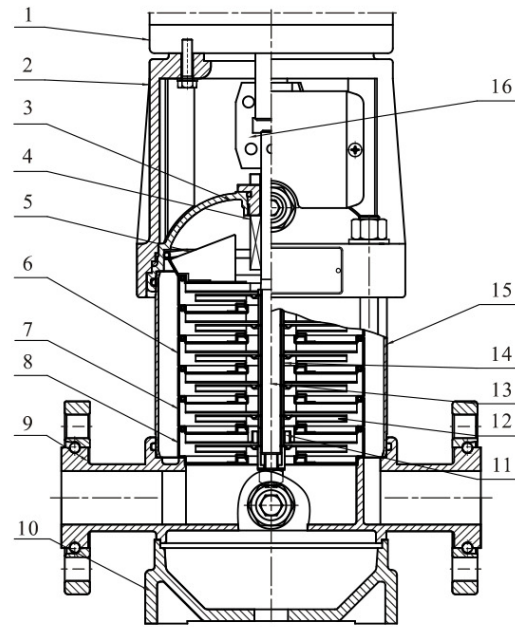

PSMFC

## Material PSM/PSMCF 1,2,3,4

NO.	Name	Material	AISI/ASTM
1	Motor		
2	Pump head	Cast iron	ASTM25B
4	Mechanical seal		
5	Top diffuser	Stainless steel	AISI304
6	Diffuser	Stainless steel	AISI304
7	Support diffuser	Stainless steel	AISI304
8	Inducer	Stainless steel	AISI304
11	Bearing	Tungsten carbide	
12	Impeller	Stainless steel	AISI304
13	Shaft	Stainless steel	AISI304 AISI316L

NO.	Name	Material	AISI/ASTM
14	Impeller sleeve	Stainless steel	AISI304
15	Cylinder	Stainless steel	AISI304
16	Coupling	Carbon steel	

PSMCF

3	Seal base	Stainless steel	AISI304
9	Inlet and outlet chamber	Stainless steel	AISI304
10	Base plate	Cast iron	ASTM25B

PSM

9	Inlet and outlet chamber	Cast iron	ASTM25B
---	--------------------------	-----------	---------



# FLO FAB'S SERIES PSM 60HZ - TECHNICAL DATA

## Section drawing PSM/PSMCF 8,12,16,20

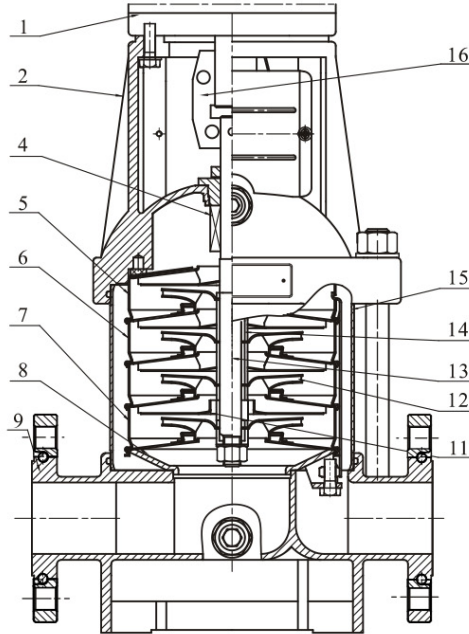

PSM

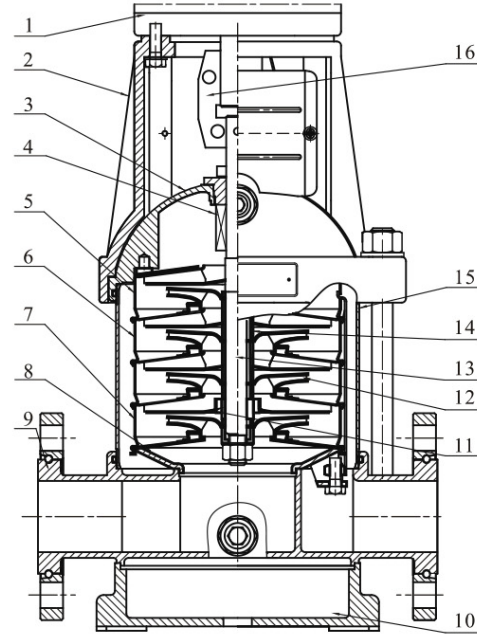

PSMCF

## Material PSM/PSMCF 8,12,16,20

NO.	Name	Material	AISI/ASTM
1	Motor		
2	Pump head	Cast iron	ASTM25B
4	Mechanical seal		
5	Top diffuser	Stainless steel	AISI304
6	Diffuser	Stainless steel	AISI304
7	Support diffuser	Stainless steel	AISI304
8	Inducer	Stainless steel	AISI304
11	Bearing	Tungsten carbide	
12	Impeller	Stainless steel	AISI304
13	Shaft	Stainless steel	AISI304 AISI316L

NO.	Name	Material	AISI/ASTM
14	Impeller sleeve	Stainless steel	AISI304
15	Cylinder	Stainless steel	AISI304
16	Coupling	Carbon steel	

### PSMCF

3	Seal base	Stainless steel	AISI304
9	Inlet and outlet chamber	Stainless steel	AISI304
10	Base plate	Cast iron	ASTM25B

### PSM

9	Inlet and outlet chamber	Cast iron	ASTM25B
---	--------------------------	-----------	---------

# FLO FAB'S SERIES PSM 60HZ - TECHNICAL DATA

## Section drawing PSM/PSMCF 32,42,65,85

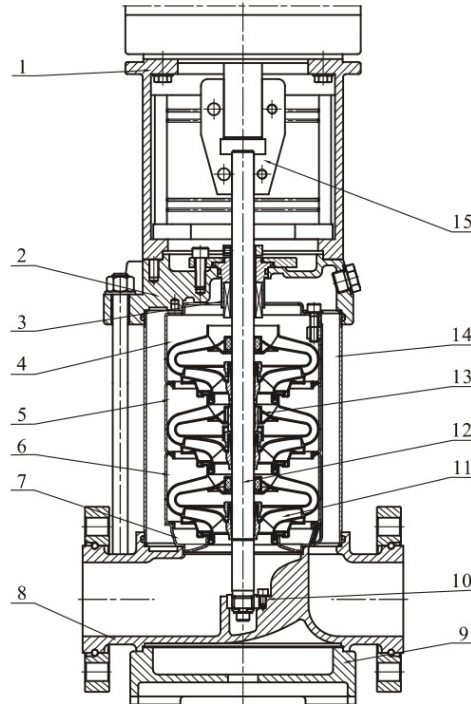

## Material PSM/PSMCF 32,42,65,85

NO.	Name	Material	AISI/ASTM	NO.	Name	Material	AISI/ASTM
1	Bracket	Cast iron	ASTM25B	12	Shaft	Stainless steel	AISI316L AISI304 AISI431
3	Mechanical seal			13	Intermediate bearing	Tungsten carbide	
4	Top diffuser	Stainless steel	AISI304	14	Cylinder	Stainless steel	AISI304
5	Support diffuser	Stainless steel	AISI304	15	Coupling	Carbon steel	
6	Diffuser	Stainless steel	AISI304		Rubber parts	NBR	
7	Inducer	Stainless steel	AISI304	PSM			
9	Base plate	Cast iron	ASTM25B	2	Pump head	Cast iron	ASTM25B
10	Bottom bearing	Tungsten carbide		8	Inlet and outlet chamber	Cast iron	ASTM25B
11	Impeller	Stainless steel	AISI304	PSMCF			
				2	Pump head	Stainless steel	AISI304
				8	Inlet and outlet chamber	Stainless steel	AISI304

# FLO FAB'S SERIES PSM 60HZ - TECHNICAL DATA

## ● Section drawing PSM/PSMCF 20,150,200

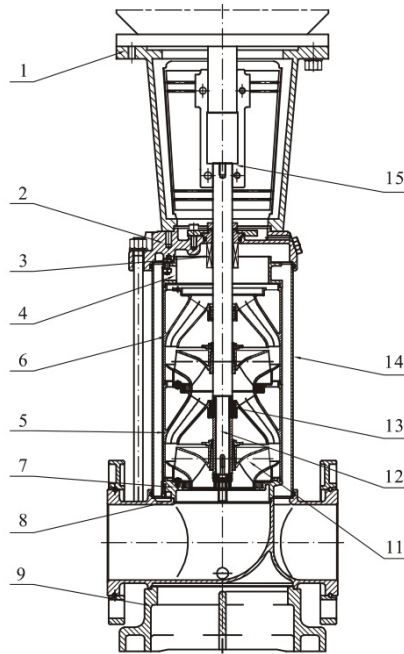

## ● Material PSM/PSMCF 20,150,200

NO.	Name	Material	AISI/ASTM	NO.	Name	Material	AISI/ASTM
1	Bracket	Cast iron	ASTM25B	13	Bearing	Tungsten carbide	
3	Mechanical seal			14	Cylinder	Stainless steel	AISI304
4	Discharge	Stainless steel	AISI304	15	Coupling	Carbon steel	
5	Support diffuser	Stainless steel	AISI304		Rubber parts	NBR	
6	Diffuser	Stainless steel	AISI304	PSM			
7	Inducer	Stainless steel	AISI304	2	Pump head	Cast iron	ASTM 80-55-06
9	Base plate	Cast iron	ASTM 80-55-06	8	Inlet and outlet chamber	Cast iron	ASTM 80-55-06
11	Impeller	Stainless steel	AISI304	PSMCF			
12	Shaft	Stainless steel	AISI304	2	Pump head	Stainless steel	AISI304
				8	Inlet and outlet chamber	Stainless steel	AISI304



# FLO FAB'S SERIES PSM 60HZ - TECHNICAL DATA

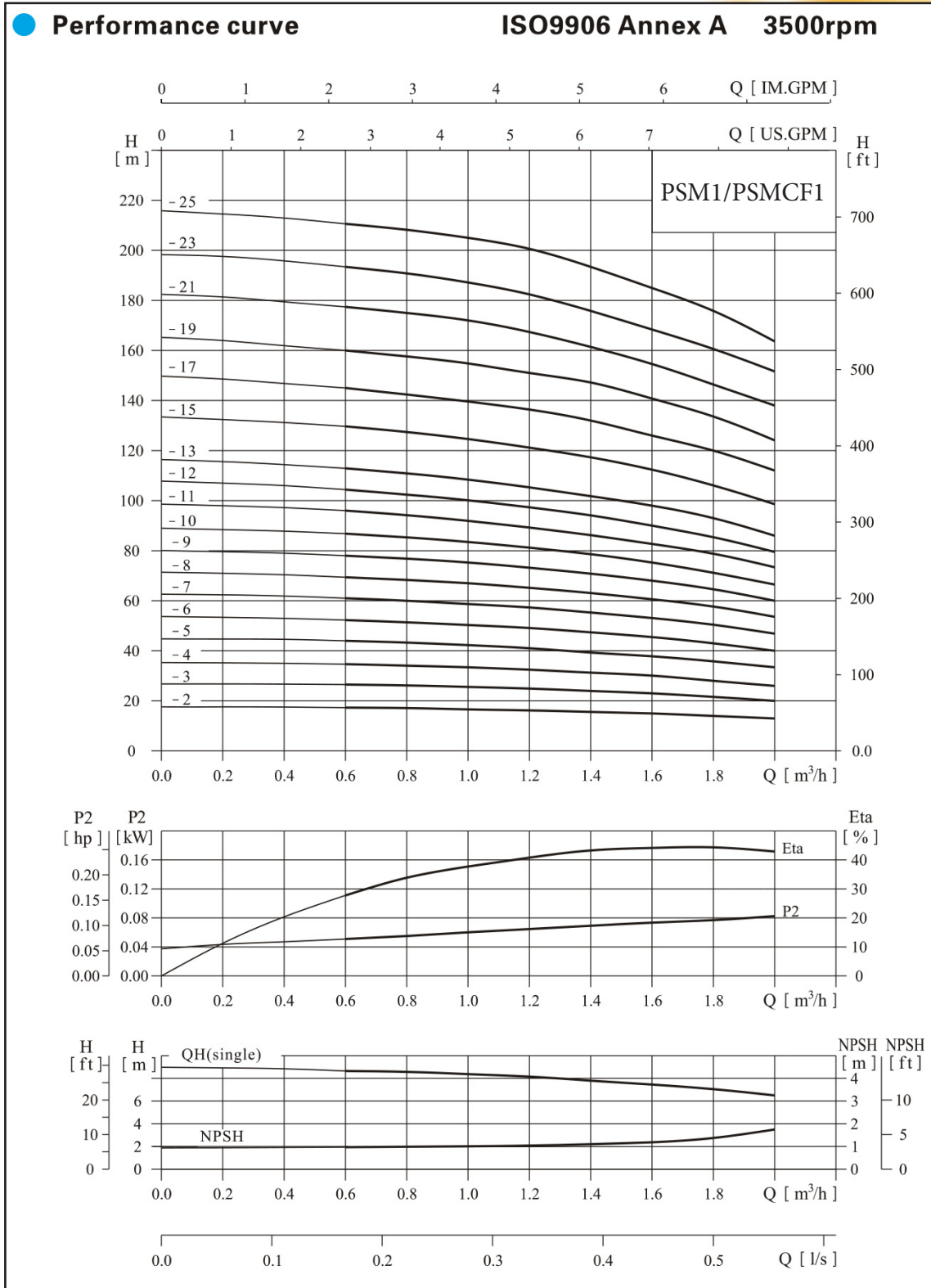

# FLO FAB'S SERIES PSM 60HZ - TECHNICAL DATA

## Performance table

Model	Driving motor		Q (m <sup>3</sup> /h)	0.6	0.8	1	1.2	1.4	1.6	1.8	2
	(kW)	(hp)									
P S M 1	2	0.37	0.5	17.5	17	16.5	16	15.5	15	14	13
	3	0.37	0.5	26.5	26	25	24	23	22	21	20
	4	0.37	0.5	35	34	33	32	31	30	28	26
	5	0.55	0.75	43	42	41	40	39	38	35	33
	6	0.55	0.75	52	51	50	48	47	45	43	39
	7	0.75	1	60	59	58	56	55	52	50	46
	8	0.75	1	68	67	65	64	62	59	57	53
	9	0.75	1	76	75	74	73	71	66	64	60
	10	1.1	1.5	85	84	83	81	78	74	72	67
	11	1.1	1.5	95	93	90	87	85	81	78	73
	12	1.1	1.5	103	102	98	96	92	88	86	79
	13	1.1	1.5	112	110	107	105	100	95	93	86
	15	1.5	2	127	125	123	121	117	112	107	99
	17	1.5	2	144	141	139	137	132	124	120	112
	19	2.2	3	160	157	155	153	147	141	134	124
21	2.2	3	177	174	172	168	162	153	147	138	
23	2.2	3	193	190	188	184	174	167	161	152	
25	3	4	210	207	205	202	192	184	176	164	

## Installation sketch

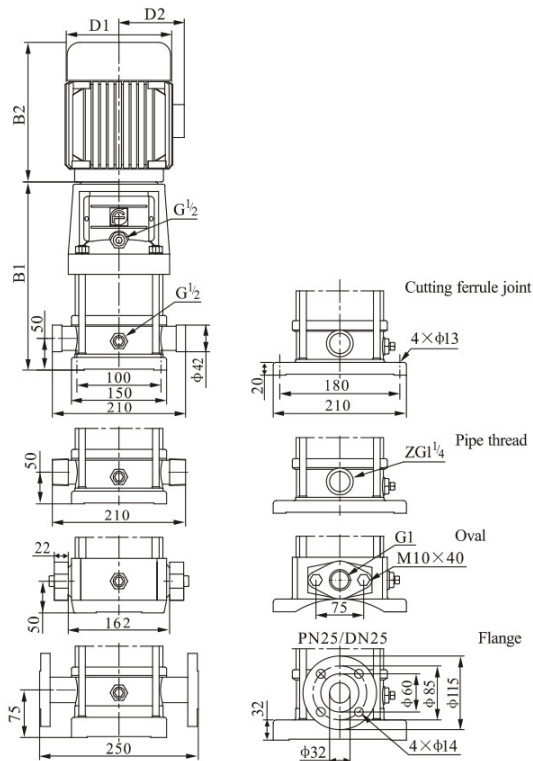

PSM1-19 ~ 1-25 sub-connection of pipeline has no oval flange connection.  
The overall dimensions of the single-phase motor and explosion-proof motor are a little different. Pls contact us for details.

## Size and weight

Model	Size (mm)					Weight (kg)	
	B1	B2	B1+B2	D1	D2		
P S M 1	2	258	210	468	148	117	20
	3	276	210	486	148	117	20
	4	294	210	504	148	117	21
	5	312	210	522	148	117	22
	6	330	210	540	148	117	23
	7	358	245	603	170	142	26
	8	376	245	621	170	142	27
	9	394	245	639	170	142	28
	10	412	245	657	170	142	29
	11	430	245	675	170	142	29
	12	448	245	693	170	142	30
	13	466	245	711	170	142	31
	15	512	290	802	190	155	37
	17	548	290	838	190	155	38
	19	584	290	874	190	155	41
21	620	290	910	190	155	42	
23	656	290	946	190	155	43	
25	702	315	1017	197	165	51	

# FLO FAB'S SERIES PSM 60HZ - TECHNICAL DATA

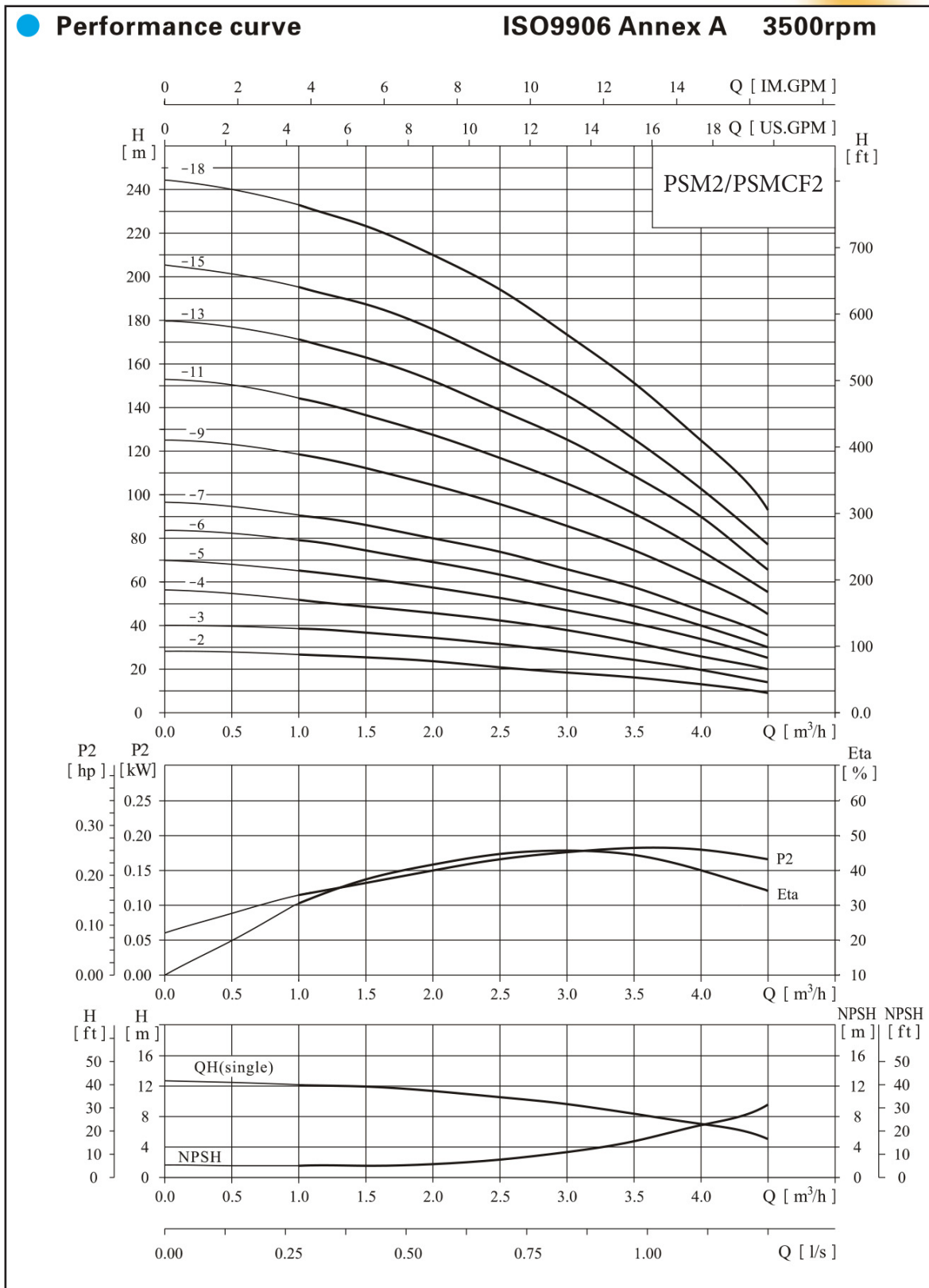

# FLO FAB'S SERIES PSM 60HZ - TECHNICAL DATA

## Performance table

Model	Driving motor		Q (m <sup>3</sup> /h)	1	1.5	2	2.5	3	3.5	4	4.5
	(kW)	(hp)									
P S M 2	2	0.55	H (m)	26	24	22	21	18	16	12	9
	3	0.75		39	36	33	31	27	24	19	15
	4	1.1		52	48	45	42	36	32	26	20
	5	1.1		65	60	57	52	46	41	32	25
	6	1.1		78	74	69	63	56	49	40	30
	7	1.5		91	86	81	74	66	57	47	35
	9	2.2		117	111	104	95	86	75	61	45
	11	2.2		143	136	128	116	104	90	75	56
	13	3		171	163	152	139	126	108	90	66
	15	3		195	186	176	160	142	125	103	77
18	4	234	228	212	195	171	151	126	94		

## Installation sketch

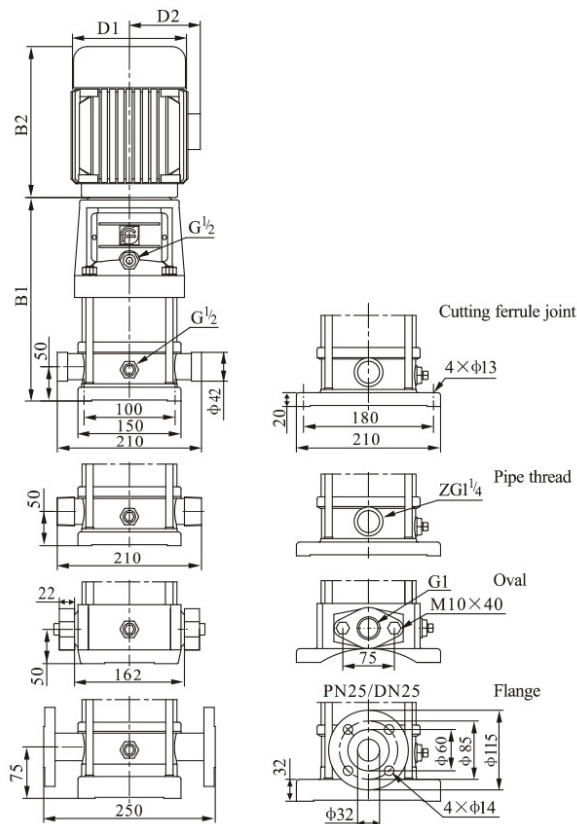

PSM2-13 ~ 2-18 sub-connection of pipeline has no oval flange connection.  
The overall dimensions of the single-phase motor and explosion-proof motor are a little different. Pls contact us for details.

## Size and weight

Model	Size (mm)					Weight (kg)	
	B1	B2	B1+B2	D1	D2		
P S M 2	2	258	210	468	148	117	21
	3	286	245	531	170	142	24
	4	304	245	549	170	142	25
	5	322	245	567	170	142	26
	6	340	245	585	170	142	26
	7	368	290	658	190	155	32
	9	404	290	694	190	155	36
	11	440	290	730	190	155	37
	13	486	315	801	197	165	44
	15	522	315	837	197	165	45
18	576	335	911	230	188	54	

# FLO FAB'S SERIES PSM 60HZ - TECHNICAL DATA

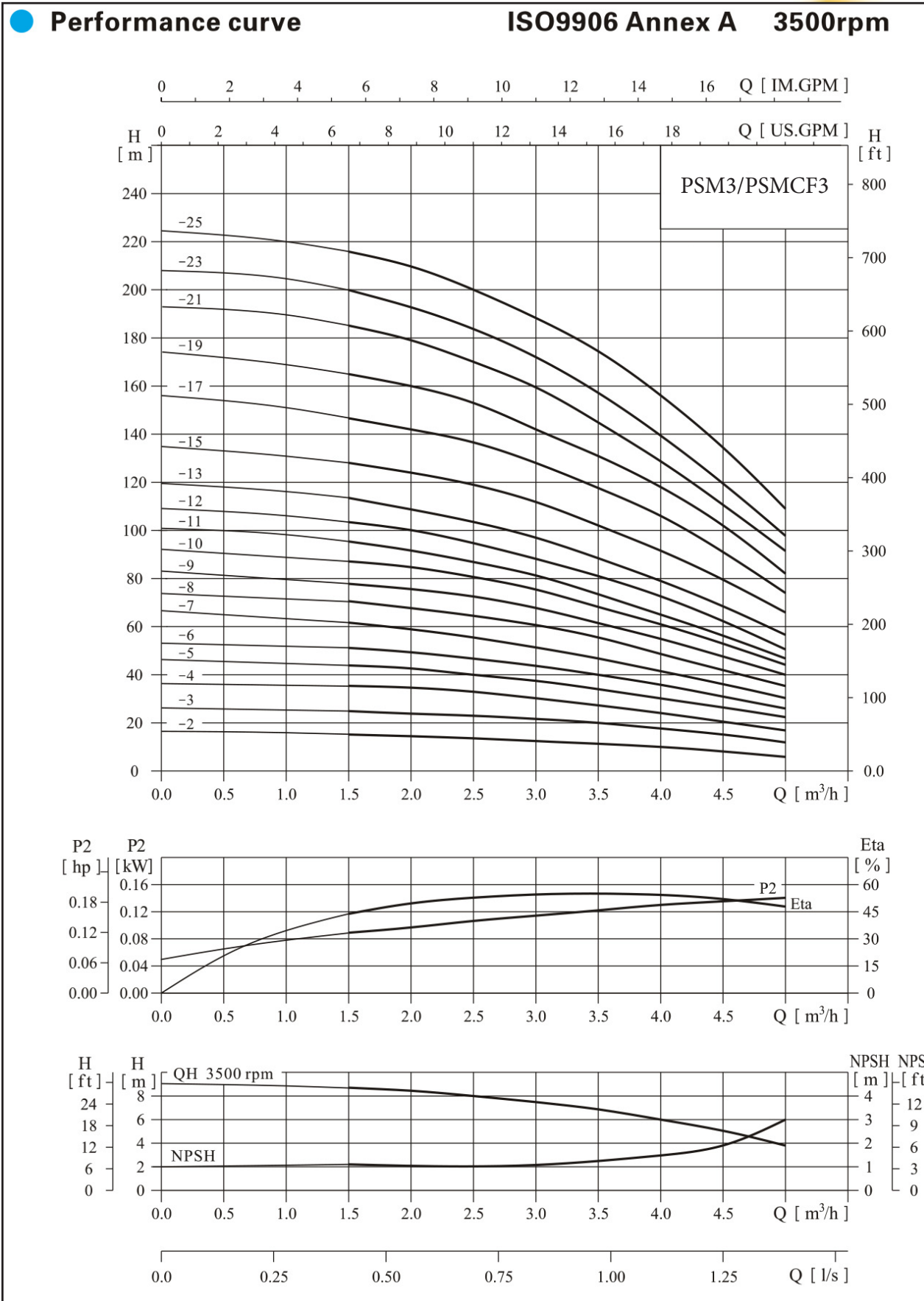



# FLO FAB'S SERIES PSM 60HZ - TECHNICAL DATA

## Performance table

Model	Driving motor		Q (m <sup>3</sup> /h)	1.5	2	2.5	3	3.5	4	4.5	5
	(kW)	(hp)									
P S M 3	2	0.37	0.5	17.5	16	15	14	13	11	9	8
	3	0.55	0.75	26.5	25	24	23	20	18	15	12
	4	0.55	0.75	35	34	32	30	27	25	20	17
	5	0.75	1	44	42	40	38	33	31	26	23
	6	1.1	1.5	51	50	48	45	40	37	32	27
	7	1.1	1.5	61	59	56	52	46	43	38	31
	8	1.1	1.5	70	67	64	61	53	49	44	35
	9	1.5	2	78	77	72	68	60	56	50	40
	10	1.5	2	87	84	81	76	68	63	55	44
	11	1.5	2	96	92	87	82	74	69	59	48
	12	2.2	3	104	100	96	90	79	73	63	52
	13	2.2	3	112	109	104	98	86	80	69	57
	15	2.2	3	129	126	120	112	99	93	81	65
	17	2.2	3	147	143	137	128	114	106	91	74
	19	3	4	165	160	153	142	126	118	102	82
21	3	4	183	178	170	160	141	129	112	91	
23	3	4	200	194	185	174	154	142	122	98	
25	4	5.5	217	211	202	187	167	154	134	108	

## Installation sketch

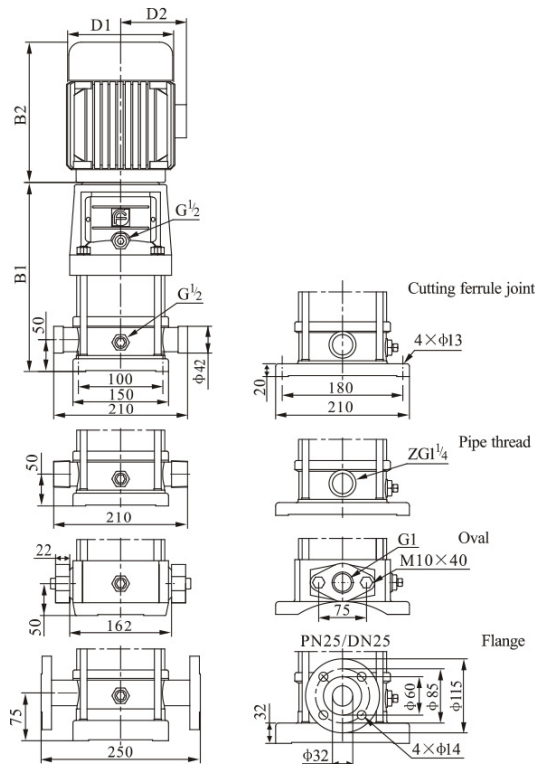

PSM3-17 ~ 3-25 sub-connection of pipeline has no oval flange connection.  
The overall dimensions of the single-phase motor and explosion-proof motor are a little different. Pls contact us for details.

## Size and weight

Model	Size (mm)					Weight (kg)	
	B1	B2	B1+B2	D1	D2		
P S M 3	2	258	210	468	148	117	20
	3	276	210	486	148	117	21
	4	294	210	504	148	117	22
	5	322	245	567	170	142	25
	6	340	245	585	170	142	26
	7	358	245	603	170	142	27
	8	376	245	621	170	142	27
	9	404	290	694	190	155	33
	10	422	290	712	190	155	34
	11	440	290	730	190	155	34
	12	458	290	748	190	155	37
	13	476	290	766	190	155	38
	15	512	290	802	190	155	39
	17	548	290	838	190	155	40
	19	594	315	909	197	165	48
21	630	315	945	197	165	49	
23	666	315	981	197	165	50	
25	702	335	1037	230	188	58	

# FLO FAB'S SERIES PSM 60HZ - TECHNICAL DATA

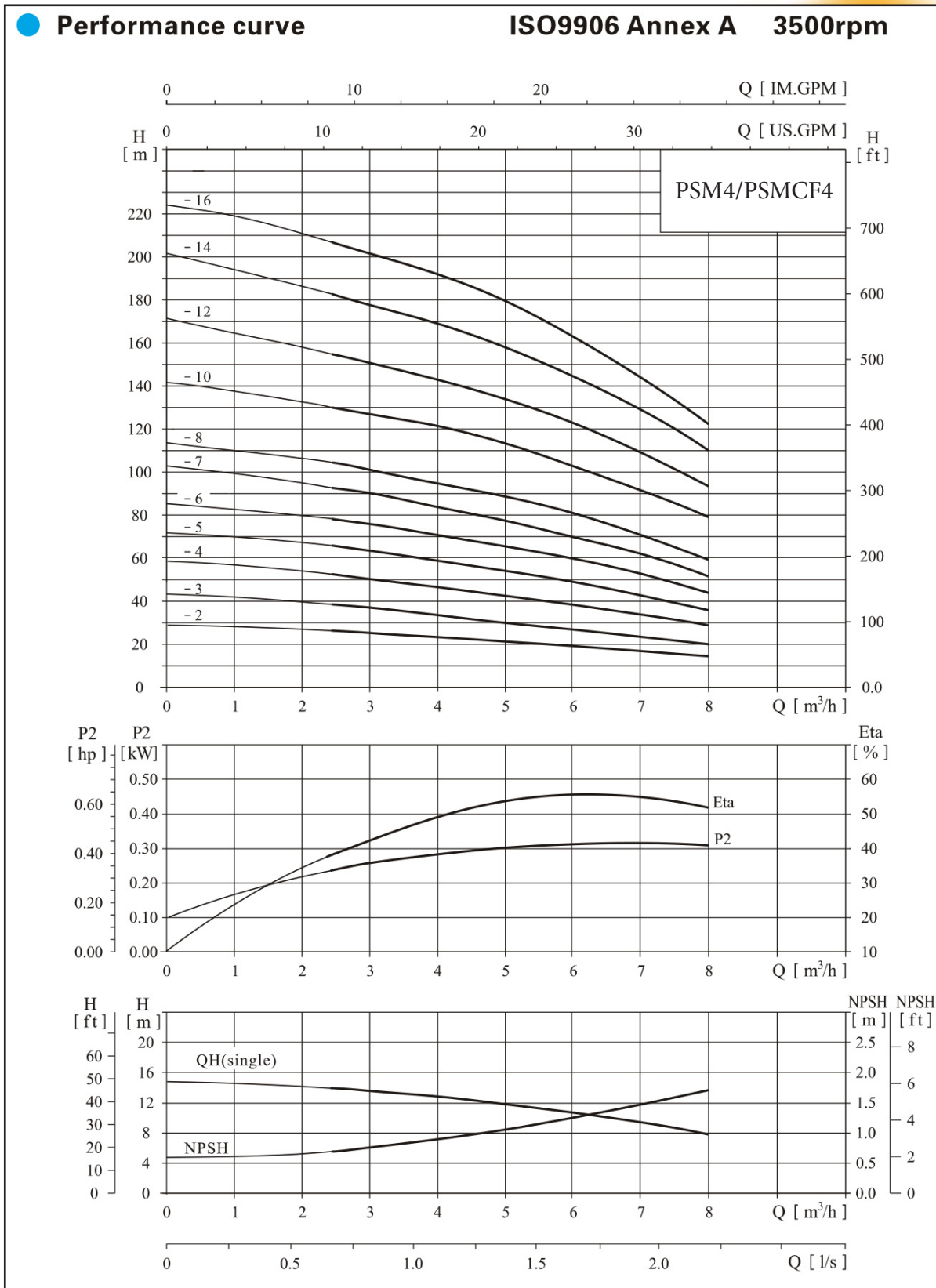

# FLO FAB'S SERIES PSM 60HZ - TECHNICAL DATA

## ● Performance table

Model	Driving motor		Q (m <sup>3</sup> /h)	2.5	3	4	5	6	7	8
	(kW)	(hp)								
P S M 4	2	0.75	1	26	25	23	21	19	16	14
	3	1.1	1.5	39	38	36	32	28	24	21
	4	1.5	2	52	50	48	44	38	35	31
	5	2.2	3	65	62	60	55	49	44	39
	6	2.2	3	78	75	72	67	59	54	47
	7	3	4	92	88	84	78	69	62	55
	8	3	4	104	100	95	90	79	72	63
	10	4	5.5	130	125	120	113	102	90	80
	12	4	5.5	156	150	145	136	122	109	96
	14	5.5	7.5	182	176	170	159	145	129	112
	16	5.5	7.5	207	201	196	183	165	146	128

## ● Installation sketch

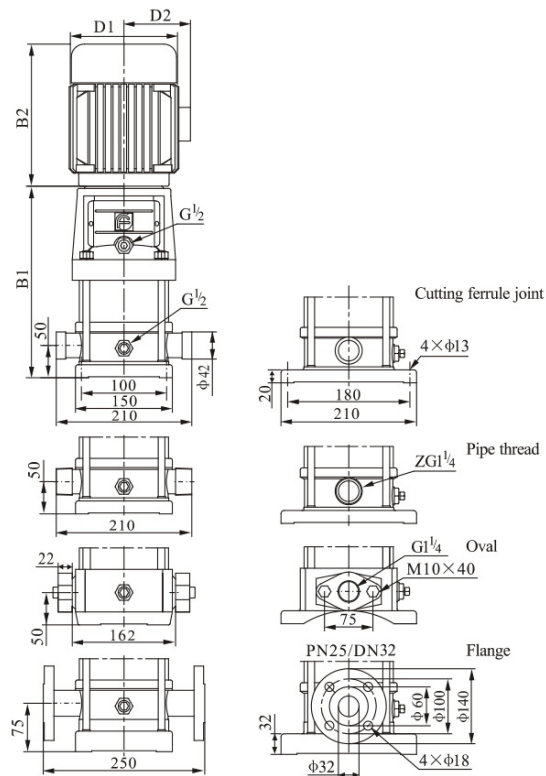

## ● Size and weight

Model	Size (mm)					Weight (kg)	
	B1	B2	B1+B2	D1	D2		
P S M 4	2	286	245	531	170	142	24
	3	313	245	558	170	142	25
	4	350	290	640	190	155	31
	5	376	290	667	190	155	34
	6	404	290	694	190	155	35
	7	441	315	756	197	165	42
	8	468	315	783	197	165	42
	10	522	335	857	230	188	51
	12	576	335	911	230	188	52
	14	650	430	1080	260	208	64
	16	704	430	1134	260	208	66

PSM4-12 ~ 4-16 sub-connection of pipeline has no oval flange connection.  
The overall dimensions of the single-phase motor and explosion-proof motor are a little different. Pls contact us for details.

# FLO FAB'S SERIES PSM 60HZ - TECHNICAL DATA

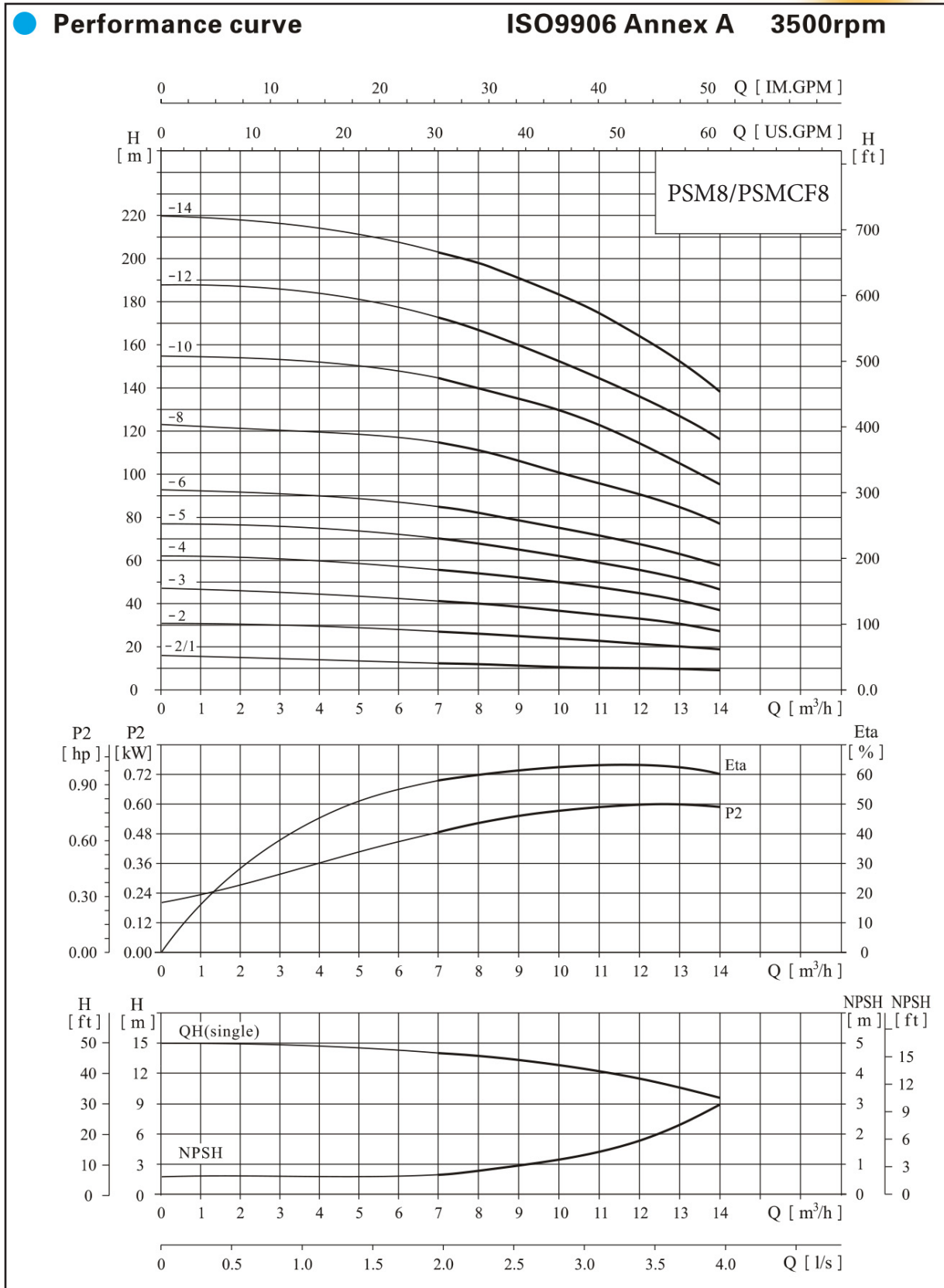

# FLO FAB'S SERIES PSM 60HZ - TECHNICAL DATA

## Performance table

Model	Driving motor		Q (m <sup>3</sup> /h)	7	8	9	10	11	12	13	14
	(kW)	(hp)									
P S M 8	2/1	0.75	1	13	12	11.5	11	10.5	10	9.5	9
	2	1.5	2	27	26	25	24	23	22	20	18
	3	2.2	3	41	40	38	37	35	33	30	28
	4	3	4	55	54	52	50	47	45	41	38
	5	3	4	70	68	65	63	59	56	52	47
	6	4	5.5	85	82	78	76	72	68	62	57
	8	5.5	7.5	115	110	105	101	97	91	84	75
	10	7.5	10	145	140	132	126	122	115	105	95
	12	7.5	10	173	167	160	152	147	132	125	115
	14	11	15	202	195	188	179	174	163	147	135

## Installation sketch

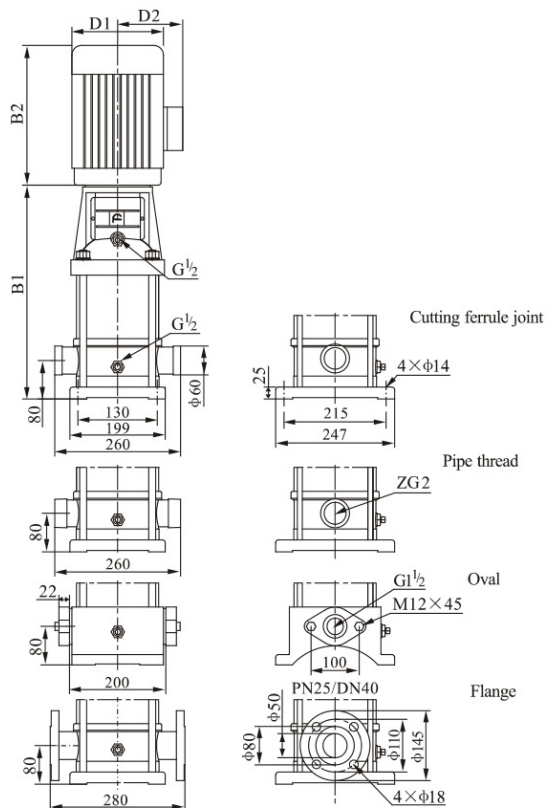

PSM8-10 ~ 8-14 sub-connection of pipeline has no oval flange connection.  
The overall dimensions of the single-phase motor and explosion-proof motor are a little different. Pls contact us for details.

## Size and weight

Model	Size (mm)					Weight (kg)	
	B1	B2	B1+B2	D1	D2		
P S M 8	2/1	347	245	592	170	142	32
	2	357	290	647	190	155	38
	3	387	290	677	190	155	41
	4	427	315	742	197	165	49
	5	457	315	772	197	165	50
	6	487	335	822	230	188	58
	8	567	430	997	260	208	71
	10	627	430	1057	260	208	80
	12	687	430	1117	260	208	82
	14	835	490	1325	330	255	153

# FLO FAB'S SERIES PSM 60HZ - TECHNICAL DATA

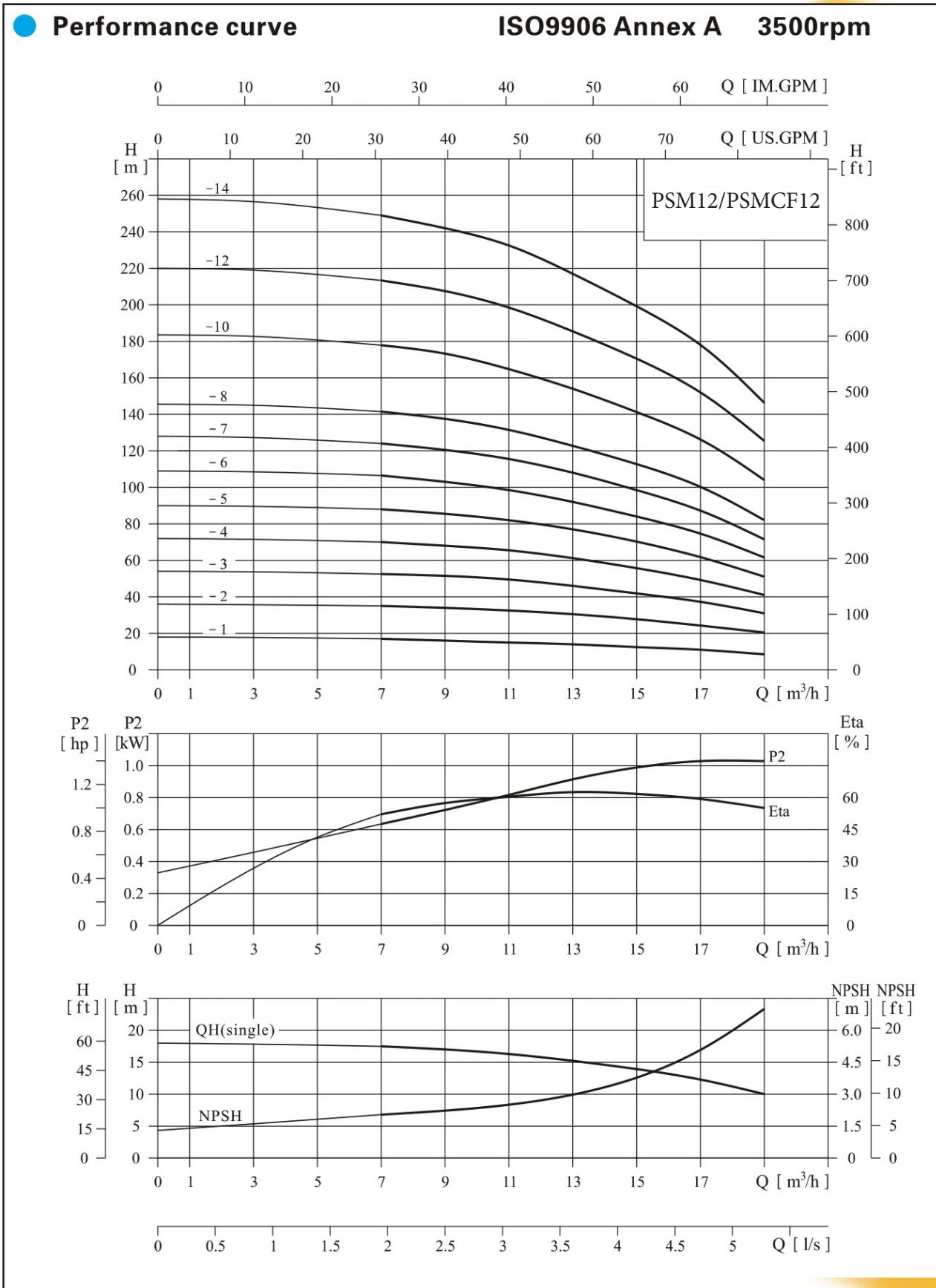



# FLO FAB'S SERIES PSM 60HZ - TECHNICAL DATA

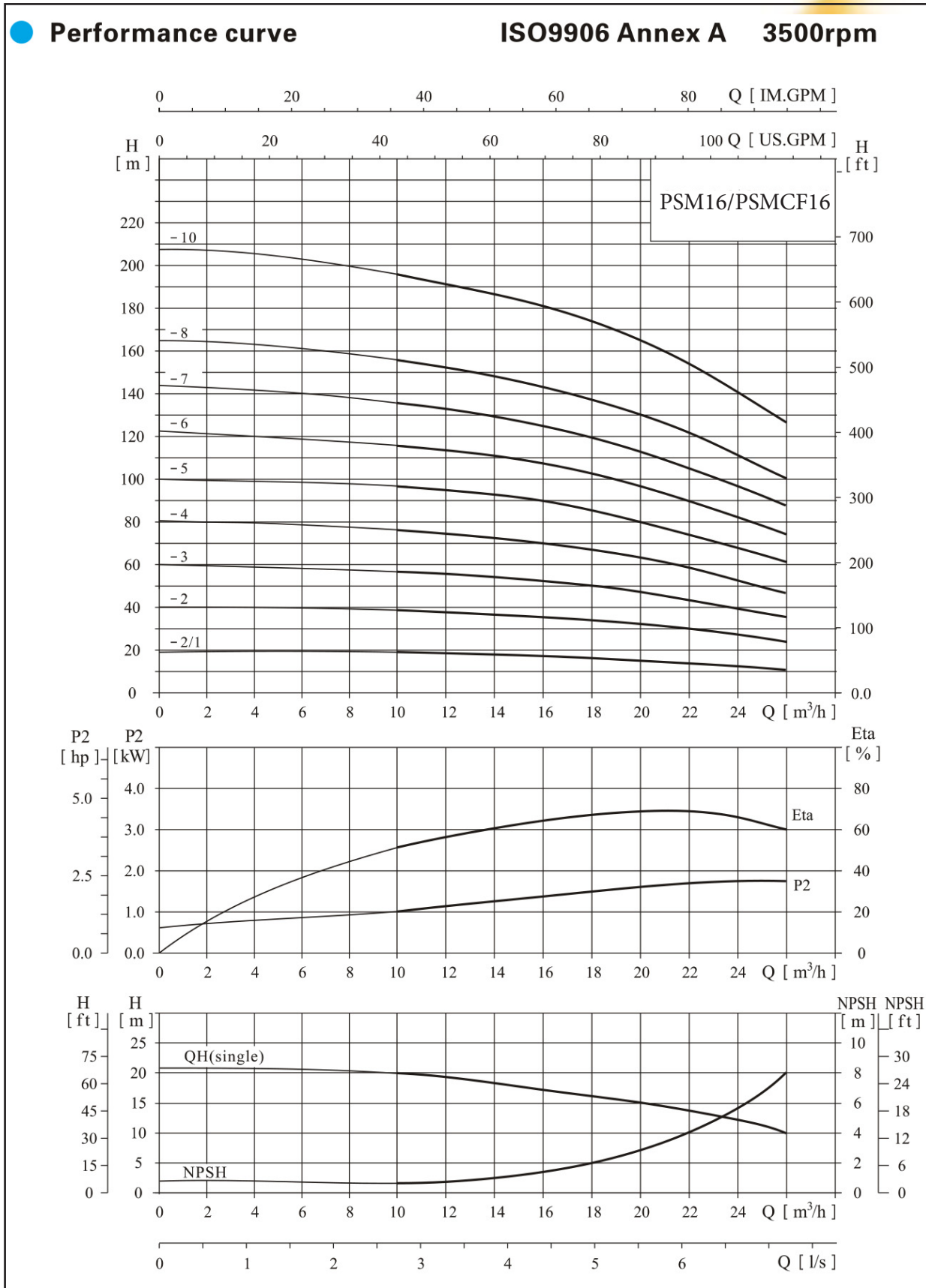



# FLO FAB'S SERIES PSM 60HZ - TECHNICAL DATA

## Performance table

Model	Driving motor		Q (m <sup>3</sup> /h)	10	12	14	16	18	20	22	24	26	
	(kW)	(hp)											
P S M 16	2/1	2.2	3	H (m)	19	18.5	18	17	16	15	14	13	11
	2	4	5.5		38	37	36	35	34	32	30	27	24
	3	5.5	7.5		57	56	55	54	51	48	45	40	36
	4	7.5	10		76	75	73	72	68	64	60	54	49
	5	11	15		96	94	92	90	85	80	75	68	62
	6	11	15		115	113	111	108	102	96	91	82	75
	7	15	20		135	132	129	126	119	113	106	96	88
	8	15	20		155	152	148	144	137	130	122	111	101
	10	18.5	25		197	192	187	181	174	165	153	139	127

## Installation sketch

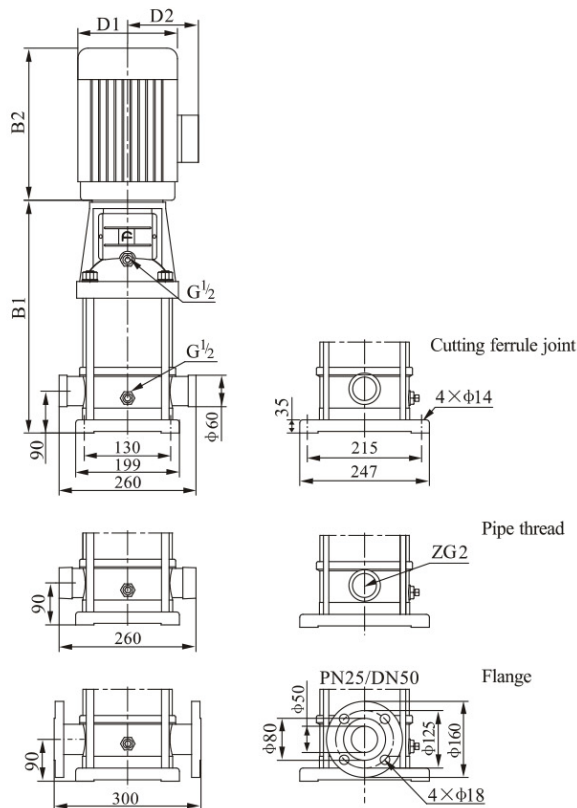

## Size and weight

Model	Size (mm)					Weight (kg)	
	B1	B2	B1+B2	D1	D2		
P S M 16	2/1	397	290	687	190	155	42
	2	407	335	742	230	188	56
	3	472	430	902	260	208	68
	4	517	430	947	260	208	75
	5	650	490	1140	330	255	148
	6	695	490	1185	330	255	150
	7	740	490	1230	330	255	161
	8	785	490	1275	330	255	163
	10	875	550	1425	330	255	186

The overall dimensions of the single-phase motor and explosion-proof motor are a little different. Pls contact us for details.

# FLO FAB'S SERIES PSM 60HZ - TECHNICAL DATA

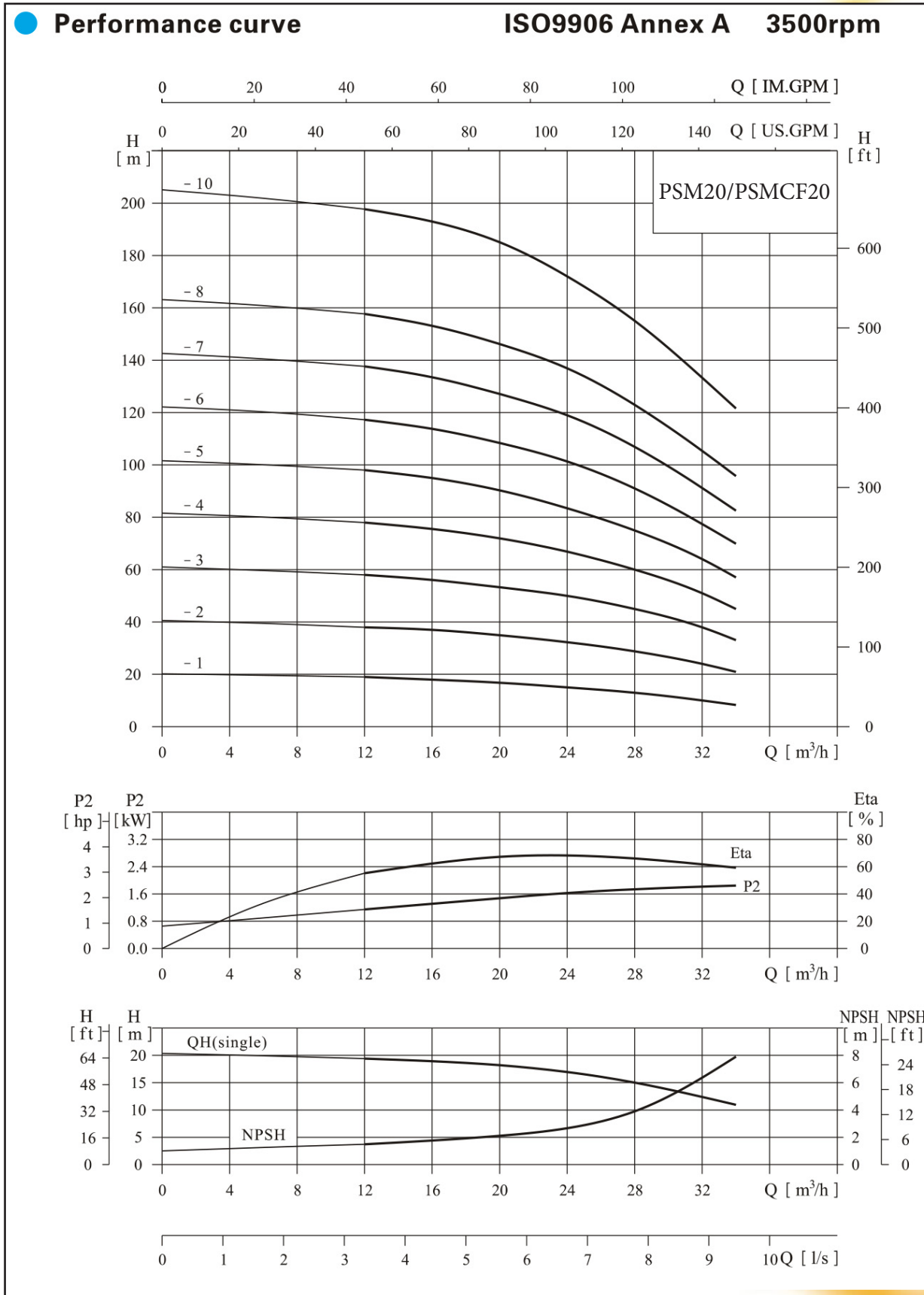

# FLO FAB'S SERIES PSM 60HZ - TECHNICAL DATA

## ● Performance table

Model	Driving motor		Q (m <sup>3</sup> /h)	12	16	20	24	28	32	34
	(kW)	(hp)								
P S M 20	1	2.2	3	19	18	17	15	13	10	8.5
	2	4.0	5.5	38	37	35	32	29	24	21
	3	5.5	7.5	58	56	53	50	45	38	33
	4	7.5	10	78	75	72	67	60	51	45
	5	11	15	98	94	90	85	75	64	57
	6	11	15	118	113	108	102	91	77	70
	7	15	20	138	133	127	119	107	91	83
	8	15	20	158	153	146	137	123	105	96
	10	18.5	25	198	193	185	172	155	133	122

## ● Installation sketch

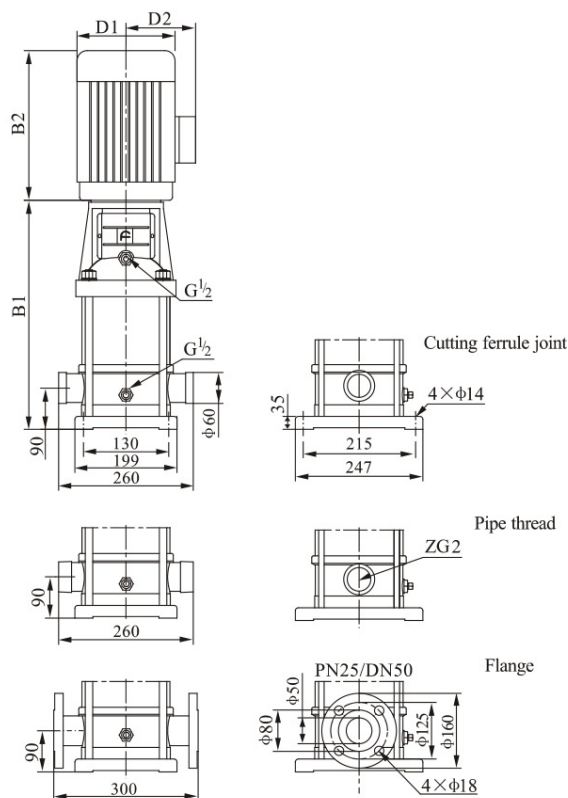

## ● Size and weight

Model	Size (mm)					Weight (kg)	
	B1	B2	B1+B2	D1	D2		
P S M 20	1	397	290	687	190	155	41
	2	407	335	742	230	188	56
	3	472	430	902	260	208	69
	4	517	430	947	260	208	79
	5	650	490	1140	330	255	148
	6	695	490	1185	330	255	150
	7	740	490	1230	330	255	162
	8	785	490	1275	330	255	163
	10	875	550	1425	330	255	187

The overall dimensions of the single-phase motor and explosion-proof motor are a little different. Pls contact us for details.

# FLO FAB'S SERIES PSM 60HZ - TECHNICAL DATA

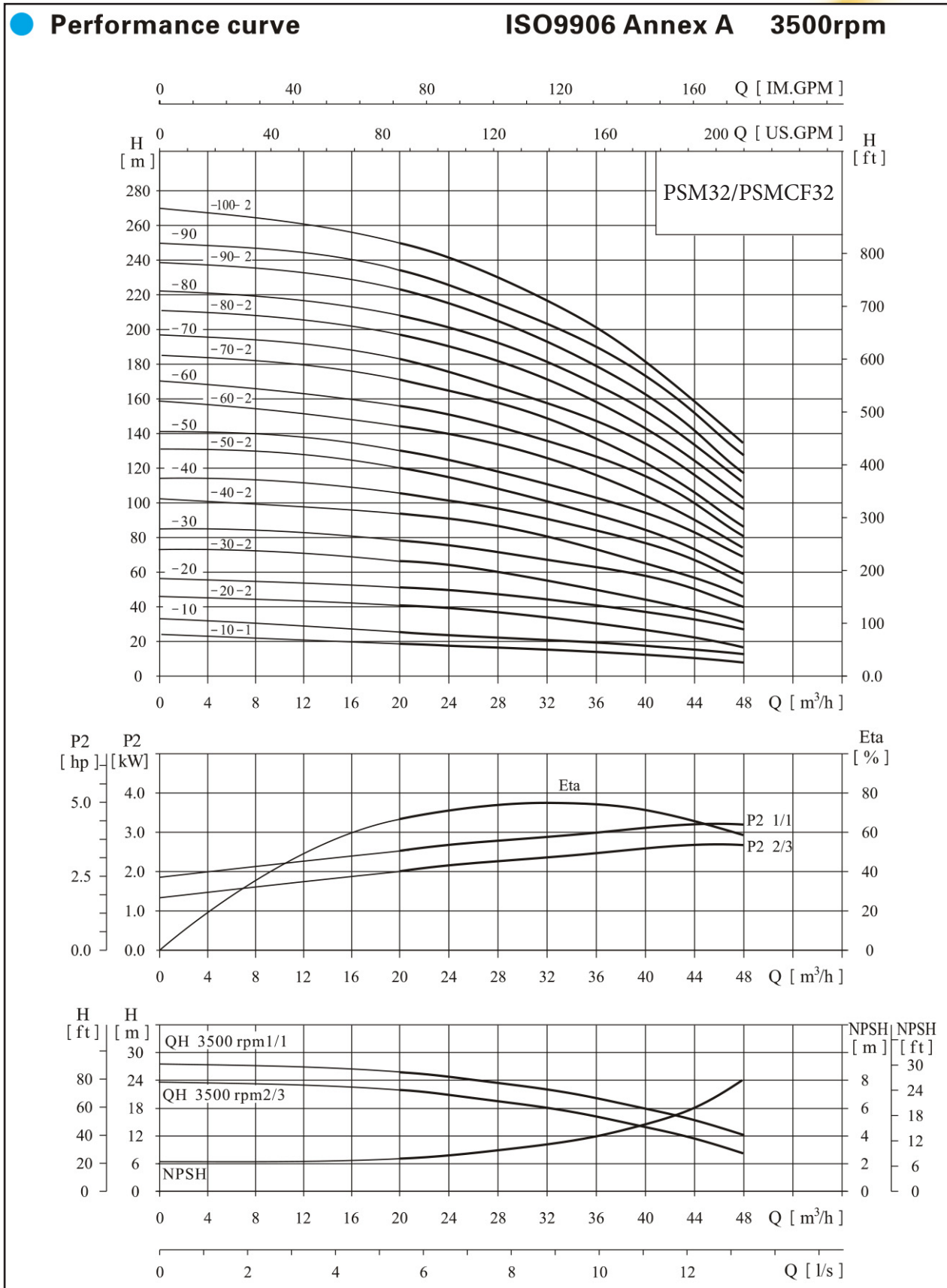

# FLO FAB'S SERIES PSM 60HZ - TECHNICAL DATA

## Performance table

Model	Driving motor		Q (m <sup>3</sup> /h)	20	24	28	32	36	40	44	48
	(kW)	(hp)									
P S M 32	-10-1	3.0	H (m)	20	19	18	17	15	13	10	7
	-10	4.0		26	25	24	23	21	19	17	14
	-20-2	5.5		41	40	38	35	31	27	22	17
	-20	7.5		52	50	48	45	41	37	33	27
	-30-2	7.5		67	64	61	57	52	46	39	31
	-30	11		78	75	71	67	62	56	50	40
	-40-2	11		94	91	87	81	73	65	56	45
	-40	15		104	101	96	91	83	75	66	55
	-50-2	15		119	115	109	102	94	84	73	59
	-50	18.5		130	125	119	112	104	94	83	69
	-60-2	18.5		145	140	134	126	116	104	90	74
	-60	18.5		155	150	144	136	126	114	100	81
	-70-2	22		172	166	158	149	137	123	106	86
	-70	22		182	176	168	159	148	133	118	97
	-80-2	22		196	190	182	172	159	143	124	102
	-80	30		208	201	192	181	167	152	132	111
	-90-2	30		223	216	206	194	179	162	142	117
	-90	30		234	226	216	204	189	172	152	127
100-2	30	248	241	231	217	201	181	159	133		

## Installation sketch

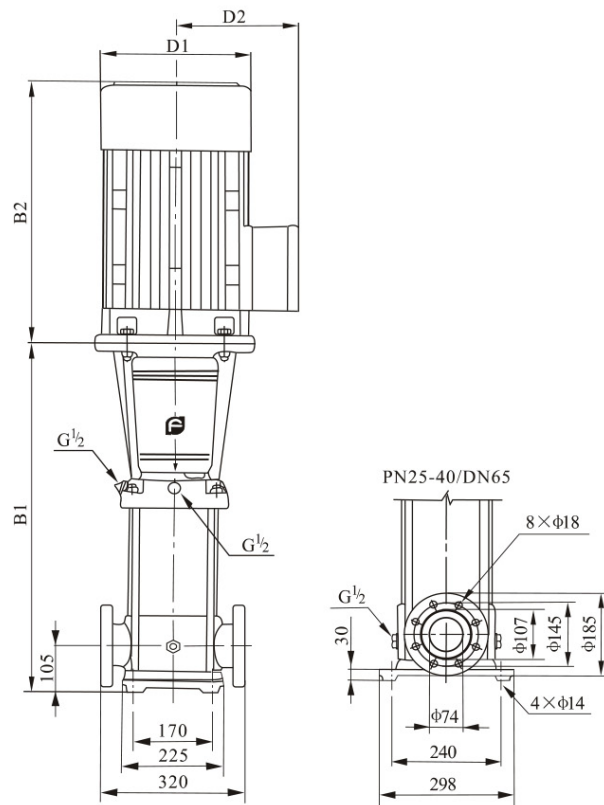

## Size and weight

Model	Size (mm)					Weight (kg)	
	B1	B2	B1+B2	D1	D2		
P S M 32	-10-1	505	315	820	197	165	73
	-10	505	335	840	230	188	81
	-20-2	575	430	1005	260	208	95
	-20	575	430	1005	260	208	101
	-30-2	645	490	1135	330	255	104
	-30	750	490	1240	330	255	172
	-40-2	820	490	1310	330	255	176
	-40	820	490	1310	330	255	186
	-50-2	890	490	1380	330	255	191
	-50	890	550	1440	330	255	211
	-60-2	960	550	1510	330	255	216
	-60	960	550	1510	330	255	216
	-70-2	1030	590	1620	360	285	255
	-70	1030	590	1620	360	285	255
	-80-2	1100	590	1690	400	310	259
	-80	1100	660	1760	400	310	315
	-90-2	1170	660	1830	400	310	319
	-90	1170	660	1830	400	310	319
100-2	1240	660	1900	400	310	324	

The overall dimensions of explosion-proof motor is a little different. Pls contact us for details.

# FLO FAB'S SERIES PSM 60HZ - TECHNICAL DATA

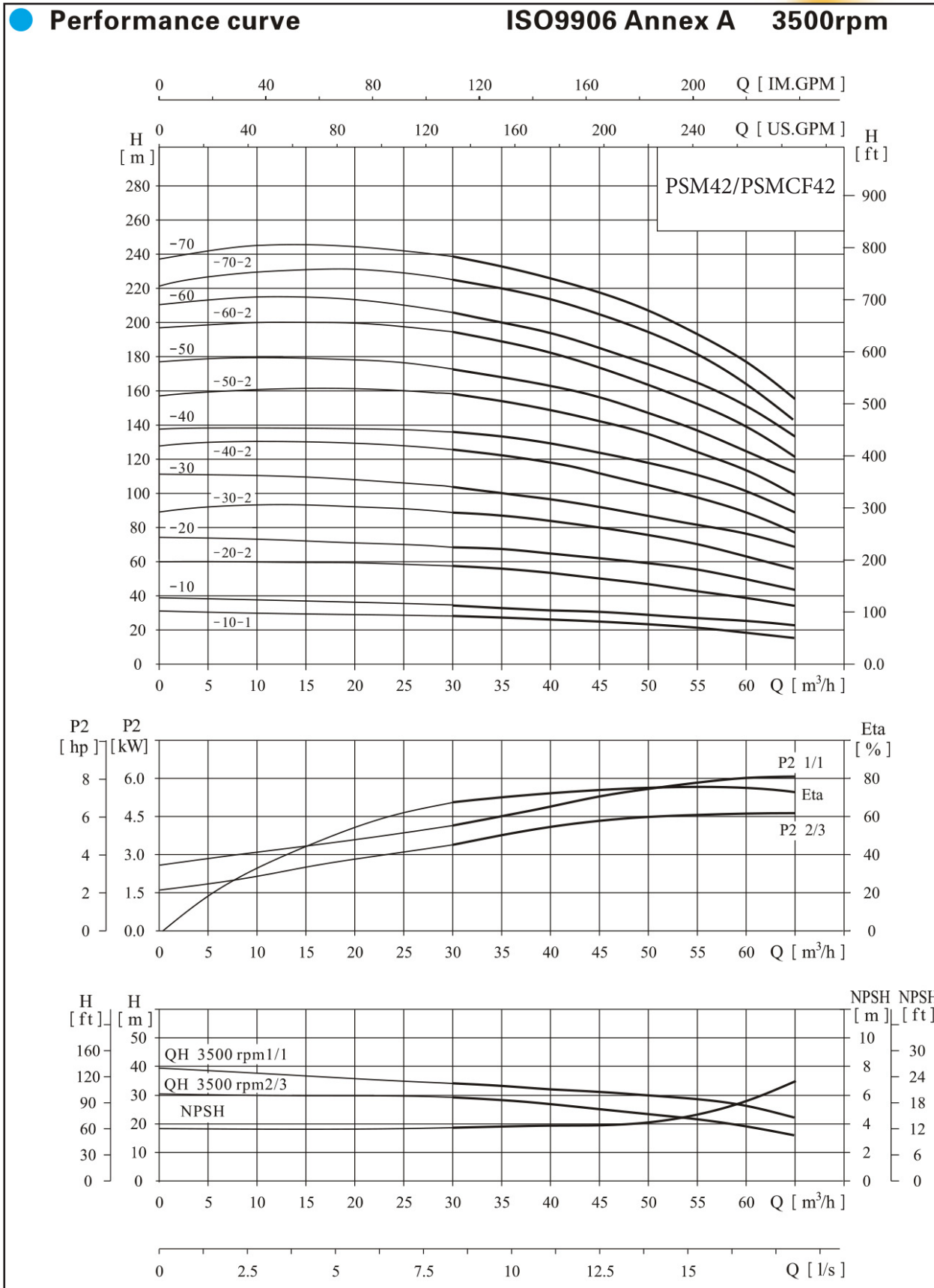

# FLO FAB'S SERIES PSM 60HZ - TECHNICAL DATA

## Performance table

Model	Driving motor		Q (m <sup>3</sup> /h)	30	35	40	42	45	50	55	60	65
	(kW)	(hp)										
P S M 42	10-1	5.5	7.5	29	28	27	26	25	23	21	19	16
	10	7.5	10	34	33	32	31.5	30	29	27	25	22
	20-2	11	15	57	55	53	52	49	46	43	38	33
	20	15	20	69	67	65	63	61	59	55	50	44
	30-2	18.5	25	90	88	85	83	80	75	72	63	55
	30	18.5	25	102	100	97	95	92	88	82	76	68
	40-2	22	30	125	121	118	115	112	105	98	89	78
	40	30	40	136	133	129	126	123	117	112	102	89
	50-2	30	40	159	154	149	146	142	134	121	115	99
	50	30	40	171	166	161	158	154	145	138	126	112
	60-2	37	50	194	188	182	178	173	163	155	139	122
	60	37	50	205	200	193	190	186	176	166	152	134
	70-2	45	60	227	220	213	210	205	193	182	165	144
	70	45	60	239	232	226	221	216	204	194	178	157

## Installation sketch

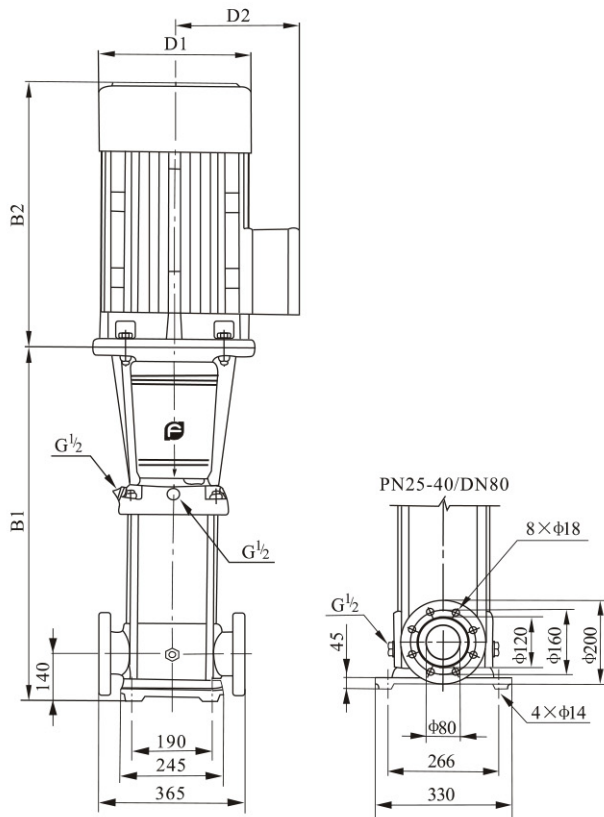

The overall dimensions of explosion-proof motor is a little different. Pls contact us for details.

## Size and weight

Model	Size (mm)					Weight (kg)
	B1	B2	B1+B2	D1	D2	
10-1	561	430	992	260	208	101
10	561	430	992	260	208	106
20-2	748	490	1238	330	255	178
20	748	490	1238	330	255	188
30-2	828	550	1378	330	255	213
30	828	550	1378	330	255	213
40-2	908	590	1498	360	285	253
40	908	660	1568	400	310	309
50-2	988	660	1648	400	310	313
50	988	660	1648	400	310	313
60-2	1068	660	1728	400	310	340
60	1068	660	1728	400	310	340
70-2	1148	700	1848	460	340	404
70	1148	700	1848	460	340	404

# FLO FAB'S SERIES PSM 60HZ - TECHNICAL DATA

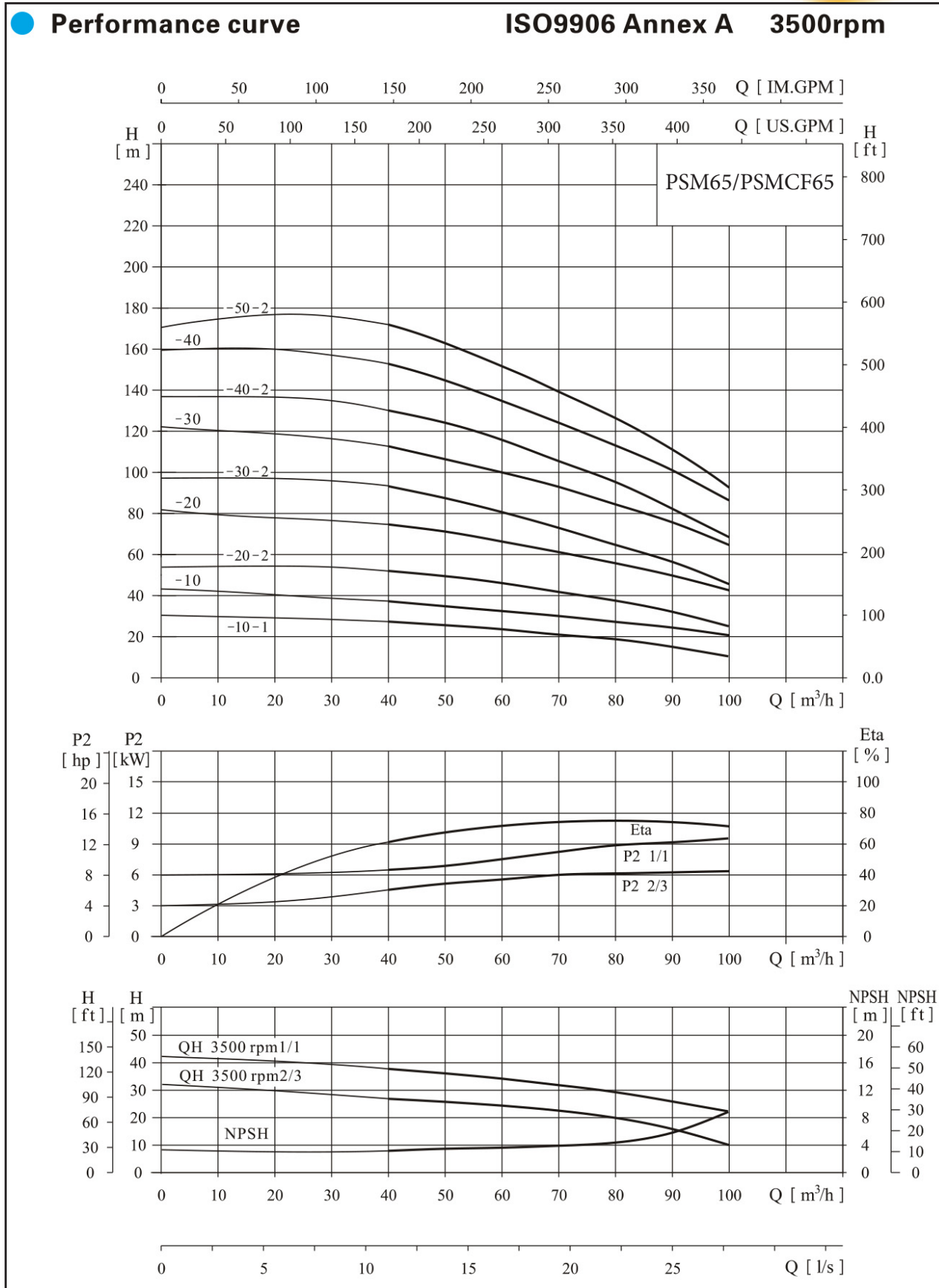



# FLO FAB'S SERIES PSM 60HZ - TECHNICAL DATA

## Performance table

Model	Driving motor		Q (m <sup>3</sup> /h)	40	50	60	65	70	80	90	100	
	(kW)	(hp)										
P S M 65	10-1	7.5	10	H (m)	26	25	23	22	21	18	14	10
	10	11	15		37	35	33	32	31	28	24	21
	20-2	15	20		53	50	47	44	42	37	31	23
	20	22	30		74	72	67	64	62	57	51	42
	30-2	22	30		93	88	80	76	72	65	56	45
	30	30	40		112	108	100	96	93	86	77	65
	40-2	37	50		130	124	115	110	103	94	83	66
	40	45	60		152	144	135	130	123	114	102	86
	50-2	45	60		172	162	151	144	137	126	112	91

## Installation sketch

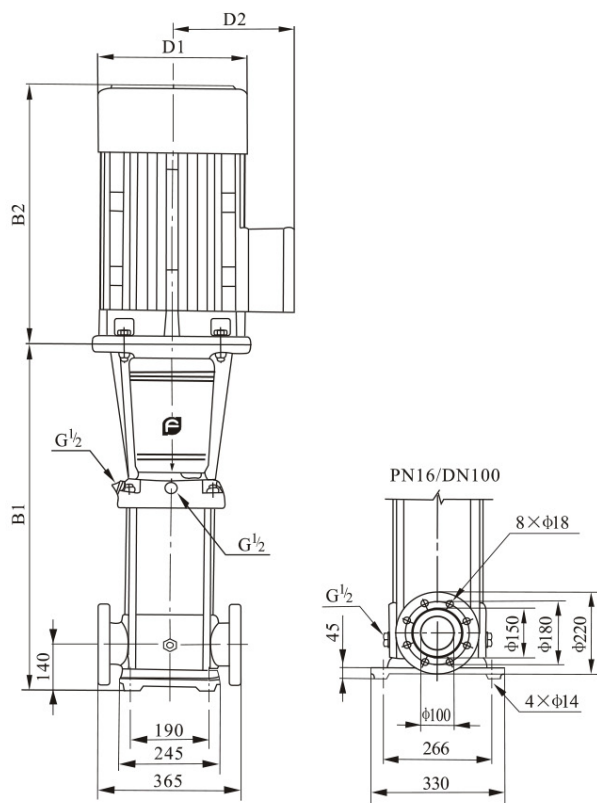

## Size and weight

Model	Size (mm)					Weight (kg)	
	B1	B2	B1+B2	D1	D2		
P S M 65	10-1	561	430	991	260	208	109
	10	671	490	1161	330	255	177
	20-2	754	490	1244	330	255	187
	20	754	590	1344	360	285	248
	30-2	836	590	1426	360	285	252
	30	836	660	1496	400	310	313
	40-2	919	660	1579	400	310	336
	40	919	700	1619	460	340	398
	50-2	1001	700	1701	460	340	402

The overall dimensions of explosion-proof motor is a little different. Pls contact us for details.  
(For PSM65 series, PN25-40/DN100 standard flange is also available if required)

# FLO FAB'S SERIES PSM 60HZ - TECHNICAL DATA

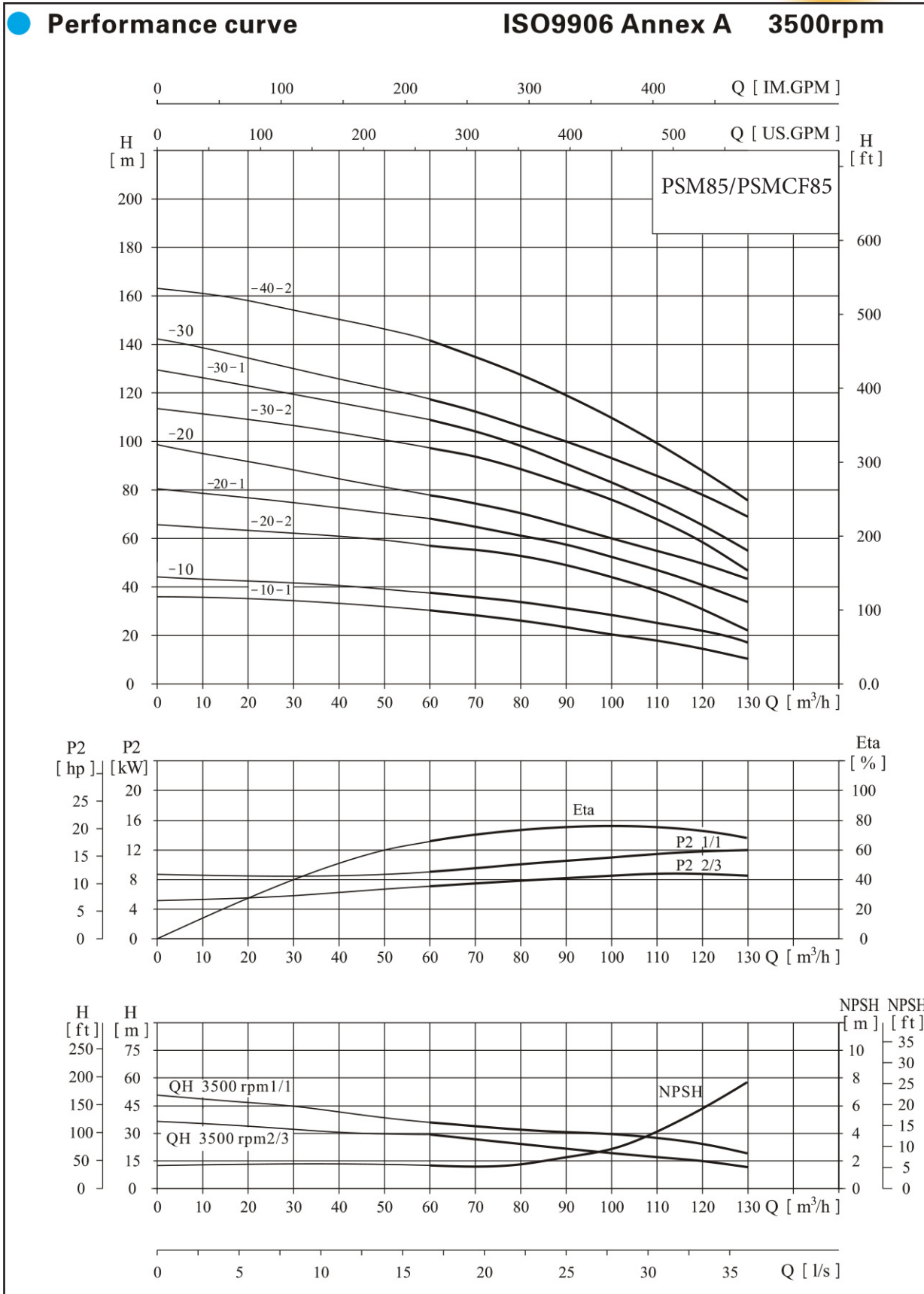

# FLO FAB'S SERIES PSM 60HZ - TECHNICAL DATA

## ● Performance table

Model	Driving motor		Q (m <sup>3</sup> /h)	60	70	80	85	90	100	110	120	130
	(kW)	(hp)										
P S M 85	10-1	11	H (m)	31	27	25	24	23	21	18	14	9
	10	15		36	35	33	31	30	29	26	23	18
	20-2	18.5		59	57	54	51	48	44	39	32	22
	20-1	22		67	65	62	59	57	51	47	41	33
	20	30		76	73	69	66	64	60	56	52	44
	30-2	37		98	94	88	85	82	75	69	59	46
	30-1	37		108	104	98	94	90	83	78	69	56
	30	45		116	111	105	102	97	93	88	79	69
	40-2	45		141	135	128	124	118	109	102	89	72

## ● Installation sketch

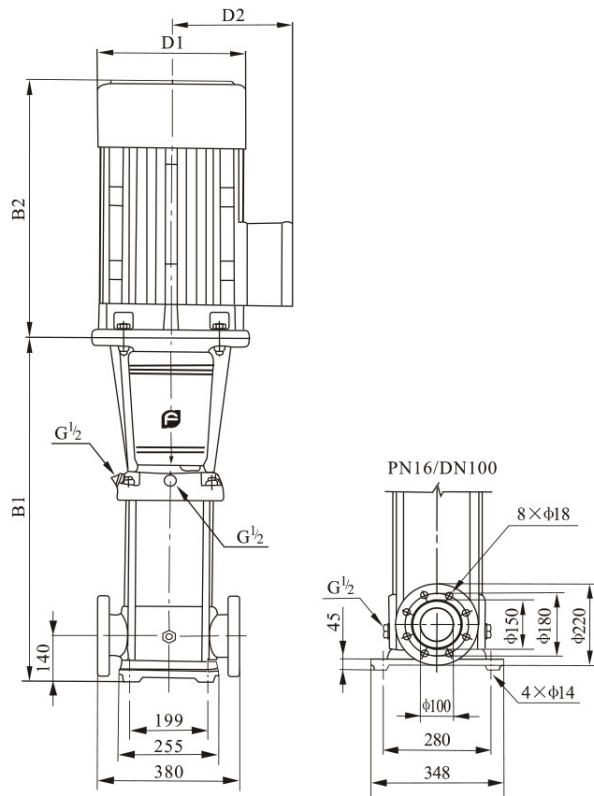

The overall dimensions of explosion-proof motor is a little different. Pls contact us for details.  
(For PSM85 series, PN25-40/DN100 standard flange is also available if required)

## ● Size and weight

Model	Size (mm)					Weight (kg)	
	B1	B2	B1+B2	D1	D2		
P S M 85	10-1	571	490	1061	330	255	177
	10	571	490	1061	330	255	188
	20-2	773	550	1323	330	255	211
	20-1	773	590	1363	360	285	248
	20	773	660	1433	400	310	304
	30-2	865	660	1525	400	310	330
	30-1	865	660	1525	400	310	330
	30	865	700	1565	460	340	392
	40-2	957	700	1657	460	340	396

# FLO FAB'S SERIES PSM 60HZ - TECHNICAL DATA

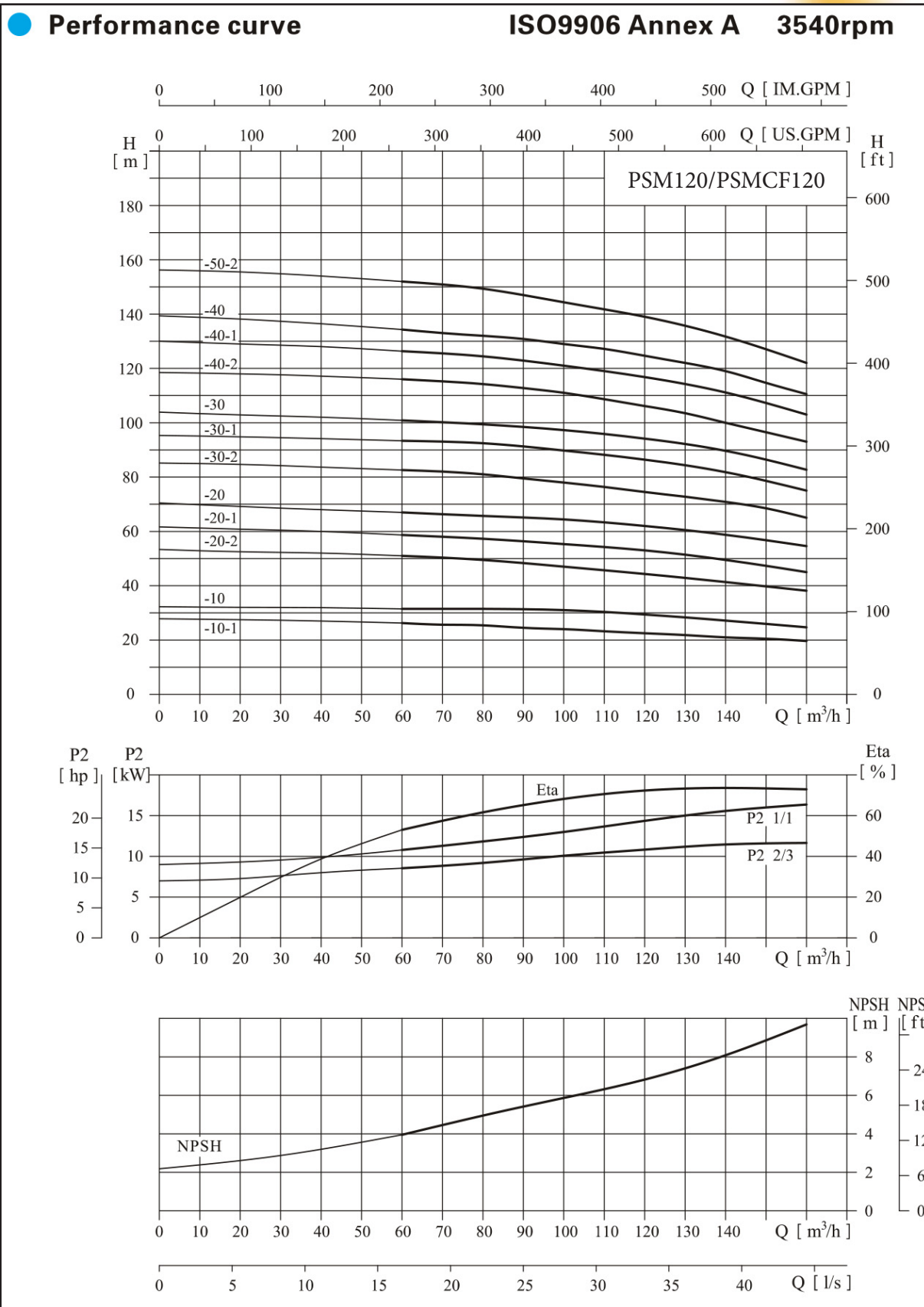

# FLO FAB'S SERIES PSM 60HZ - TECHNICAL DATA

## Performance table

Model	Driving motor		Q (m <sup>3</sup> /h)	H (m)										
	(kW)	(hp)		60	70	80	90	100	110	120	130	140	150	160
P S M 120	.10-1	15	20	26.5	26	25	24.5	23.8	23	22.5	21.5	21.3	21	20
	.10	18.5	25	30.8	30.7	30.7	30.5	30.3	29.5	28.8	27.6	26.4	25.4	24.4
	.20-2	30	40	51.5	50.5	49.5	47.5	46	45.5	44.8	43	41	39.7	38.5
	.20-1	30	40	58.3	58	57.3	56	54.7	54	53	51.5	50	47.4	45
	.20	37	50	66.3	66	65.7	65	64.4	63	62	60.7	59.6	57	54.6
	.30-2	45	60	83	82	81	79.5	78	76	74.5	73.5	71	68.5	65
	.30-1	45	60	91.3	91	90.4	89	87.7	86	84.4	82	80	76.7	73.3
	.30	55	75	100.3	100	99.4	98.3	97.3	95.5	94	92	90	86.3	82.7
	.40-2	75	100	116	115.5	114	113	111	109	105.5	104	100	97	93
	.40-1	75	100	126	125.4	124.6	122.6	120.6	118.5	116.5	114	111.3	107	103
	.40	75	100	134	133	132	131	129.5	127.5	125	122	119	114.5	109.5
	.50-2	75	100	152	151	149.7	147	144	141.5	139	135.5	132	127	122

## Installation sketch

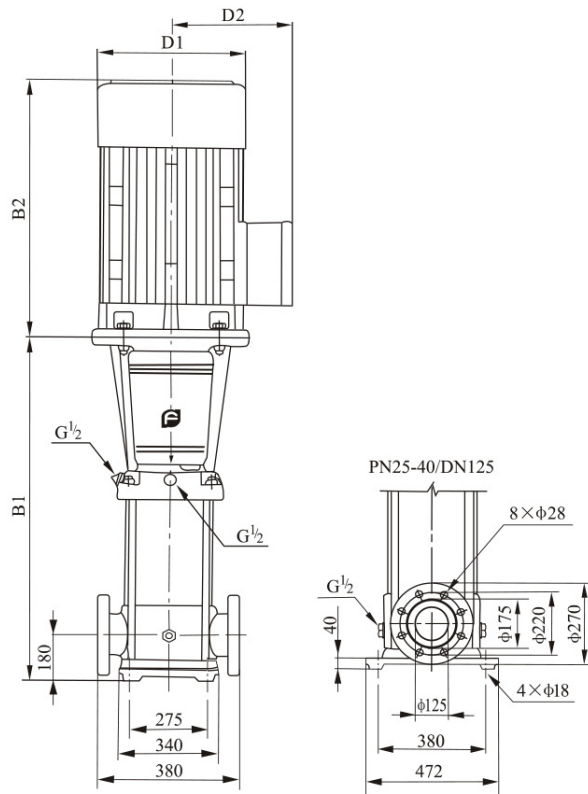

## Size and weight

Model	Size (mm)					Weight (kg)	
	B1	B2	B1+B2	D1	D2		
P S M 120	.10-1	840	490	1330	330	255	235
	.10	840	550	1390	330	255	250
	.20-2	1000	660	1660	400	310	350
	.20-1	1000	660	1660	400	310	350
	.20	1000	660	1660	400	310	380
	.30-2	1160	700	1860	460	340	445
	.30-1	1160	700	1860	460	340	445
	.30	1190	770	1960	510	370	545
	.40-2	1350	845	2195	580	410	675
	.40-1	1350	845	2195	580	410	675
	.40	1350	845	2195	580	410	675
	.50-2	1510	845	2355	580	410	690

The overall dimensions of explosion-proof motor is a little different. Pls contact us for details.

# FLO FAB'S SERIES PSM 60HZ - TECHNICAL DATA

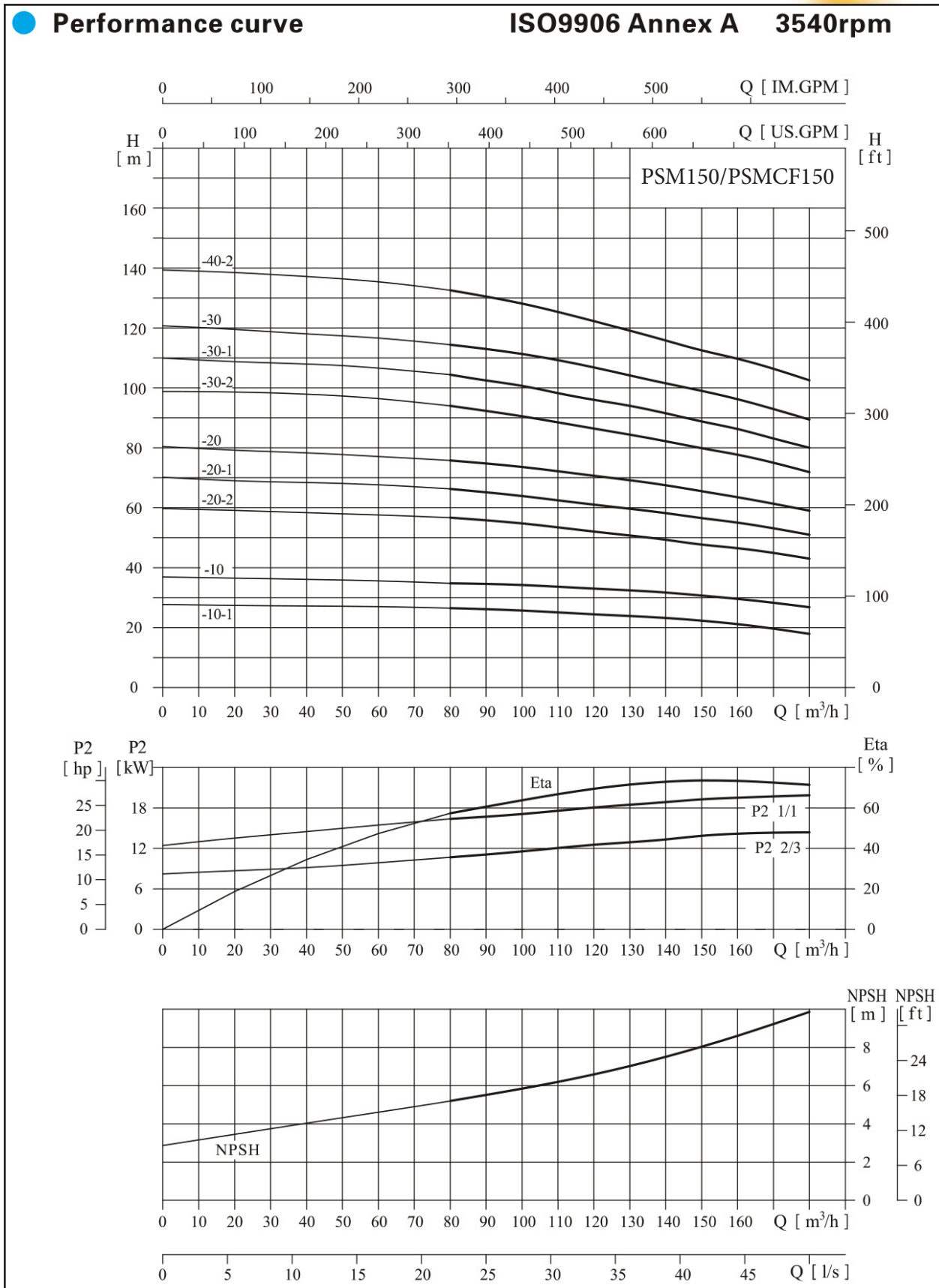

# FLO FAB'S SERIES PSM 60HZ - TECHNICAL DATA

## ● Performance table

Model	Driving motor		Q (m <sup>3</sup> /h)	80	90	100	110	120	130	140	150	160	170	180
	(kW)	(hp)												
P S M 150	10-1	15	20	26.5	26	25.7	25	24.3	23.8	23.2	22.3	21.2	19.5	18
	10	22	30	35	34.5	34	33.6	33	32.3	31.7	30.7	29.6	28	27
	20-2	30	40	57	55.5	53	52	51.3	50	49	48	47	45	43
	20-1	37	50	67	65	63.5	62	61	60	58.5	56	55	53	51
	20	45	60	75.5	74.5	73.6	72	70.4	69	67.5	65.5	63.5	61	59
	30-2	55	75	94	92	90.5	88.4	86.4	83.8	81	80	78	75.3	72.5
	30-1	75	100	104	102.5	100	98	96	94	92	89	87	84	80
	30	75	100	114.4	113	111.3	109	106.5	104	101.5	99	96	93	89.4
	40-2	75	100	133	130.3	127.6	124.6	121.7	118.3	115	112.5	110	106.3	102.5

## ● Installation sketch

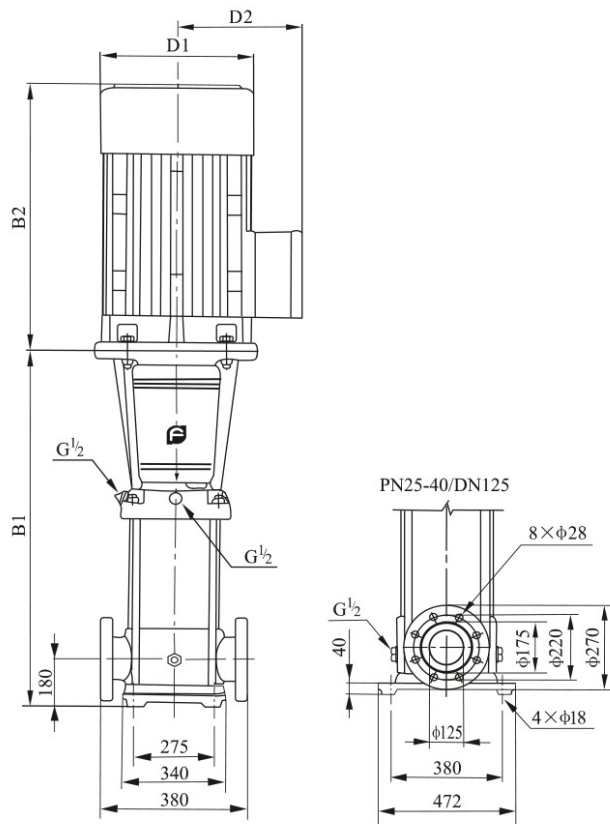

## ● Size and weight

Model	Size (mm)					Weight (kg)
	B1	B2	B1+B2	D1	D2	
10-1	840	490	1330	330	255	235
10	840	590	1430	360	285	280
20-2	1000	660	1660	400	310	360
20-1	1000	660	1660	400	310	380
20	1000	700	1700	460	340	435
30-2	1190	770	1960	510	370	545
30-1	1190	845	2035	580	410	665
30	1190	845	2035	580	410	665
40-2	1350	845	2195	580	410	680

The overall dimensions of explosion-proof motor is a little different. Pls contact us for details.

# FLO FAB'S SERIES PSM 60HZ - TECHNICAL DATA

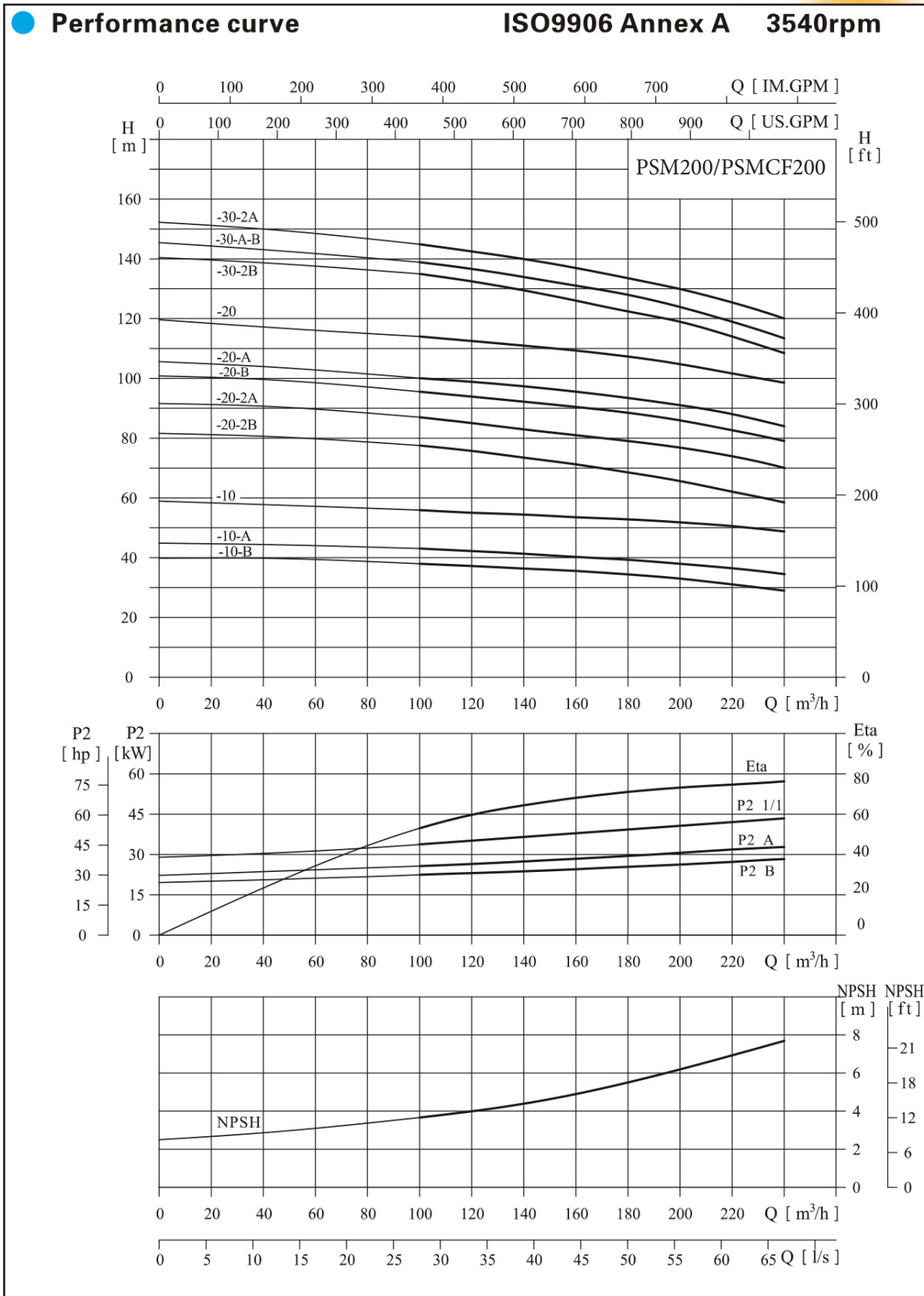



# FLO FAB'S SERIES PSM 60HZ - TECHNICAL DATA

## ● Performance table

Model	Driving motor		Q (m <sup>3</sup> /h)	100	120	140	160	180	200	220	240	
	(kW)	(hp)										
P S M 200	-10-B	30	40	H (m)	38	37	36.5	35.5	34	33	31	29
	-10-A	37	50		43	42	41.5	40	39	38	36.5	34.5
	-10	45	60		56	55	54.5	53.5	53	52	50.5	48.5
	-20-2B	55	75		77.5	75.5	73.5	71	68.5	66	62	58.5
	-20-2A	75	100		87	85	83	81	79	77	74	70
	-20-B	75	100		95.5	93.5	92.5	90.5	88.5	86	82.5	79
	-20-A	90	120		100	98.5	97.5	95.5	93.5	91	88	84
	-20	90	120		114	112.5	111	109.5	107.5	105	101.5	98.5
	-30-2B	110	150		135	132.5	129.5	126	122.5	119	114	108.5
	-30-A-B	110	150		139	136.5	134	131	128	124	119	113.5
	-30-2A	110	150		145	142.5	140	137	133.5	130	125.5	120

## ● Installation sketch

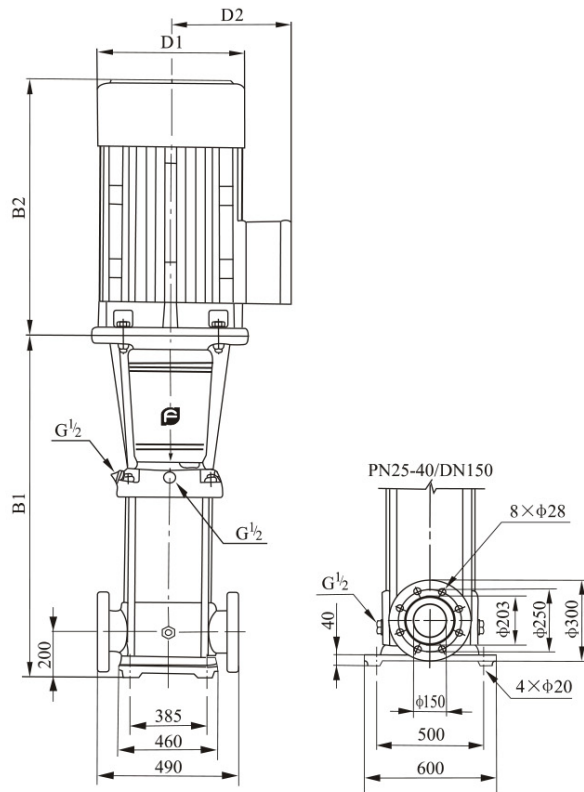

The overall dimensions of explosion-proof motor is a little different. Pls contact us for details.

## ● Size and weight

Model	Size (mm)					Weight (kg)	
	B1	B2	B1+B2	D1	D2		
P S M 200	10-B	907	660	1567	400	310	403
	10-A	907	660	1567	400	310	426
	10	907	700	1607	450	345	484
	20-2B	1131	770	1901	540	370	595
	20-2A	1131	845	1976	580	410	718
	20-B	1131	845	1976	580	410	718
	20-A	1131	895	2026	580	410	787
	20	1131	895	2026	580	410	787
	30-2B	1325	1140	2465	645	550	1158
	30-A-B	1325	1140	2465	645	550	1158
	30-2A	1325	1140	2465	645	550	1158



We are proud supplier for the following completed and on going projects :



**Bethware Elementary  
High School**

115 Bethware Dr, Kings Mountain, NC, United States



**Cegep du Vieux  
Montreal**

Old Montreal College.  
255 Ontario Est  
Montreal, Quebec, CA



**Ratiopharm Inc.**  
17800 Rue Lapointe,  
Mirabel, QC, CA



**Campus 99**  
5151 Côte Ste-Catherine  
Montréal, QC, CA

**Sales and Service:**

Quebec, Canada  
Tel. : (450) 621-2995  
Fax : (450) 621-4995

Lake Worth  
Florida, USA  
33467-5749

Toronto, Canada  
Tel. : +1 (647) 544-2995

**www.flofab.com**

SERVICE 24/7 : parts@flofab.com

