



SB,SBI,SBN 1,3,5,10,15,20,32,45,64,90,120,150 series

Vertical Multistage Centrifugal
In-line Pumps

NEMA 60Hz



Contents

Vertical Multistage Centrifugal In-line Pumps



SB, SBI, SBN Series Performance range 60Hz

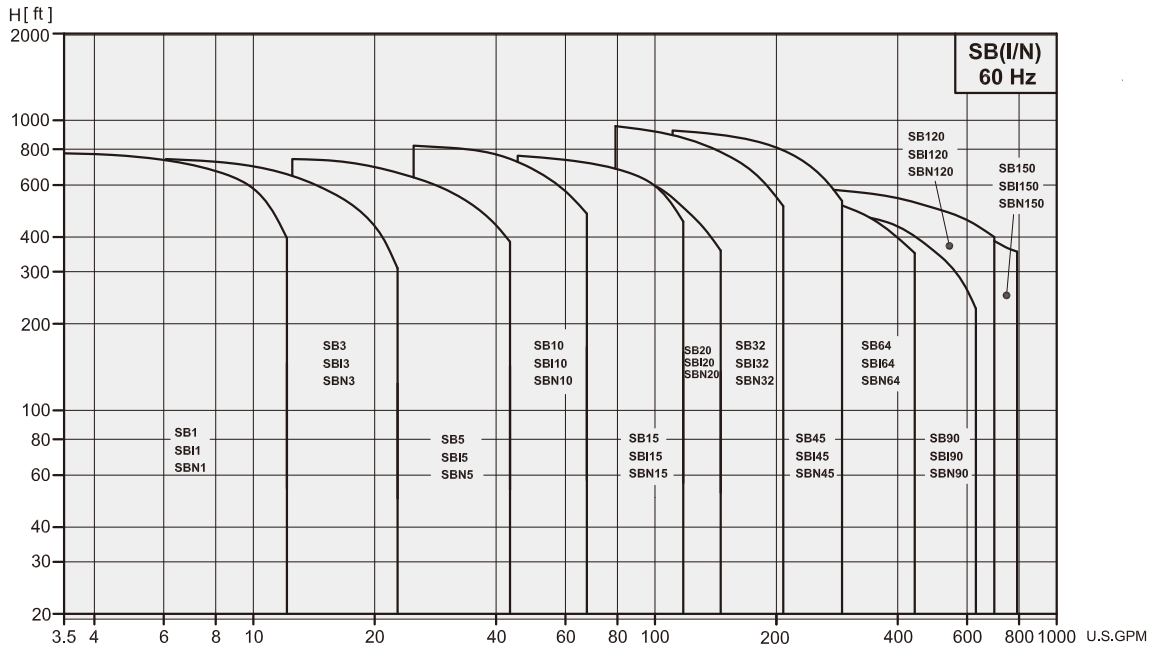

Contents

Vertical Multistage Centrifugal In-line Pumps



Product data

Range	1	3	5	10	15	20
Nominal flow [US gpm]	8.5	15	30	55	95	110
Flow range [US gpm]	3.5 - 12.8	6.6 - 23.8	13.2 - 44	26.4 - 68	46.2 - 123	55 - 154
Max pressure [psi]	341	338	334	355	341	297
Fluid temperature [°F]	5 to 250					
Motor power [HP]	0.33-3	0.33-5	0.75-7.5	0.75-15	2-25	3-25

Vesion						
SB: Cast iron and Stainless steel EN 1.4301/AISI 304	●	●	●	●	●	●
SBI: Stainless steel EN 1.4301/AISI 304	●	●	●	●	●	●
SBN: Stainless steel EN 1.4401/AISI 316	●	●	●	●	●	●

SB Pipe Connection						
Flange (ANSI) - size	1.25"	1.25"	1.25"	2"	2"	2"
Flange (ANSI) - class	250 lb.	250 lb.	250 lb.	250 lb.	250 lb.	250 lb.
Oval (NPT)	1"	1"	1.25"	2"	2"	2"

SBI Pipe Connection						
Flange (ANSI) - size	1.25"	1.25"	1.25"	2"	2"	2"
Flange (ANSI) - class	300 lb.	300 lb.	300 lb.	300 lb.	300 lb.	300 lb.
Oval (NPT)	1"	1"	1.25"	2"	2"	2"

SBN Pipe Connection						
Flange (ANSI) - size	1.25"	1.25"	1.25"	2"	2"	2"
Flange (ANSI) - class	300 lb.	300 lb.	300 lb.	300 lb.	300 lb.	300 lb.
Victaulic	1.25"	1.25"	1.25"	2"	2"	2"

Mechanical Seals	
SiC/SiC	Standard

Seals	
EPDM	Standard
Viton	

*Flange standards : Refer to dimensional drawings

Contents

Vertical Multistage Centrifugal In-line Pumps



Product data

Range	32	45	64	90	120	150
Nominal flow [US gpm]	140	220	340	440	610	750
Flow range [US gpm]	79 - 210	116 - 308	159 - 449	237 - 630	264 - 700	330 - 790
Max pressure [psi]	429	408	258	257	268	242
Fluid temperature [°F]	5 to 250					
Motor power [HP]	3-40	7.5-60	7.5-60	15-60	20-100	25-100

Version						
SB: Cast iron and Stainless steel EN 1.4301/AISI 304	●	●	●	●	●	●
SBI: Stainless steel EN 1.4301/AISI 304	●	●	●	●	●	●
SBN: Stainless steel EN 1.4401/AISI 316	●	●	●	●	●	●

SB, SBI, SBN Pipe Connection						
Flange (ANSI) - size	2.5"	3"	4"	4"	5"	5"
Flange (ANSI) - class	125/250 lb.	125/250 lb.	125/250 lb.	125/250 lb.	125/250 lb.	125/250 lb.

Mechanical Seals	
SiC/SiC	Standard

Seals	
EPDM	Standard
Viton	

*Flange standards : Refer to dimensional drawings

Contents

Vertical Multistage Centrifugal In-line Pumps



Model Code

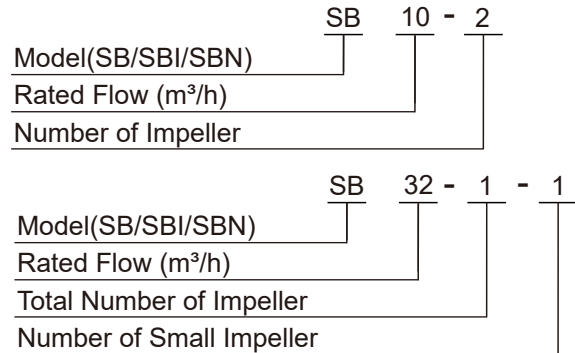

* Impeller with small diameter

Applications

- Water supply and pressure boosting
Pressure boosting in buildings, hotels, residential complexes
Pressure booster stations, supply of water networks
Pressure boosting for industrial water supply
- Light industry
Washing and cleaning systems
Car washing facilities
Fire fighting systems
Process water systems
Machine tools (cooling lubricants)
- Heating, ventilation and air-conditioning
Boilers
Induction heating
Heat exchangers
Refrigerators
Cooling towers and systems
Temperature control systems
- Irrigation and agriculture
Greenhouses
Sprinkler irrigation
Field irrigation (flooding)
- Water treatment
Water softeners and de-mineralization
Reverse Osmosis systems
Distillation systems
Filtration
Ultra-filtration systems

Pump

The SB, SBI and SBN pumps are non-self priming vertical multistage pump of in-line design, flange or with Victaulic coupling with equally sized suction and discharge ports.

Stage construction with stainless steel impellers, chambers and pressure casing.

All pumps are equipped with a cartridge type mechanical seal for easy maintenance.

SB, SBI and SBN pumps have different pump sizes and various numbers of stages to provide the flow and the pressure required.

Contents

Vertical Multistage Centrifugal In-line Pumps



Pump Nameplate Information

Type	①	
Model	②	⑧
f	③	Hz
P2	⑨	kW
n	④	min ⁻¹
H _{max}	⑩	m
Q	⑤	m ³ /h
H	⑪	m
p _{max} /t _{max}	⑥	bar/°C
Serial No.	⑦	⑫

CE

- ① Pump Type
- ② Pump Model
- ③ Frequency
- ④ Revolutions Per Minute
- ⑤ Flow rate
- ⑥ Max. Operating Pressure / Max. temperature
- ⑦ Date of manufacture
- ⑧ Seal Type
- ⑨ Rated Output Power
- ⑩ Maximum Head
- ⑪ Rated Head
- ⑫ Serial number

Mechanical Seals

Standard Cartridge type mechanical seal made of Silicon Carbide/Silicon Carbide/EPDM or Viton. Based on the type of application, alternative materials are available for the seal and the elastomers. The cartridge type mechanical seal can be replaced in minutes without special tools and without dismantling the pump.

Seal Type	SB,SBI,SBN		
	1,3,5,10,15, 20,32,45,64,90	120,150	
		0.5-60HP	75.0-100.0HP
S: O-ring seal Cartridge type	●	●	-
B: Rubber bellows seal Cartridge type	-	-	●
Seals Face Material			
QQ	●	●	●
UU	○	○	-
QB	○	○	-
UB	○	○	-
Rubber Material			
E	●	●	●
V	○	○	○

List of Materials	
Q : Silicon Carbide	E: EPDM
U: Tungsten Carbide	V: Viton
B: Carbon	



● Std. ○ Opt. - N/A

Contents

Vertical Multistage Centrifugal In-line Pumps



Motor Data

60Hz

Motor Type				Frame	
Pole	HP	kW	Ph	TEFC motors (C-face)	ODP motors (C-face)
2	1/3	0.25	1	56C	- - -
			3		
	1/2	0.37	1	56C	- - -
			3		
	3/4	0.55	1	56C	- - -
			3		
	1	0.75	1	56C	- - -
			3		
	1 1/2	1.1	1	56C	- - -
			3		
	2	1.5	1	56C	- - -
			3		
	3	2.2	1	182TC	- - -
			3		
	5	3.7	1	213TC	- - -
			3	182TC	
	7 1/2	5.5	1	213TC	- - -
			3		
	10	7.5	1	213TC	- - -
			3		
15	11	3	254TC	254TC	
20	15	3	254TC	254TC	
25	18.5	3	284TSC	284TSC	
30	22	3	286TSC	284TSC	
40	30	3	286TSC	286TSC	
50	37	3	326TSC	324TSC	
60	45	3	364TSC	324TSC	
75	55	3	365TSC	364TSC	
100	75	3	405TSC	365TSC	

Contents

Vertical Multistage Centrifugal In-line Pumps



Maximum operating and inlet pressures

Max. Operating Pressure				Stage	Max. inlet Pressures
Stage	flange(ANSI) / Victaulic	Stage	Oval flange		
SB, SBI, SBN 1		SB, SBI 1		SB, SBI, SBN 1	
2-27	362 Psi	2-17	232 Psi	2-25	145 Psi
				27	217 Psi
SB, SBI, SBN 3		SB, SBI 3		SB, SBI, SBN 3	
2-25	362 Psi	2-17	232 Psi	2-17	145 Psi
				19-25	217 Psi
SB, SBI, SBN 5		SB, SBI 5		SB, SBI, SBN 5	
2-24	362 Psi	2-16	232 Psi	2-9	145 Psi
				10-24	217 Psi
SB, SBI, SBN 10		SB, SBI 10		SB, SBI, SBN 10	
SB, SBI 1-10	232 Psi	SB 1-6	145 Psi	1-5	116 Psi
SB, SBI 12-17	362 Psi				
SBN 1-17	362 Psi	SBI 1-10	232 Psi	6-17	145 Psi
SB, SBI, SBN 15		SB, SBI 15		SB, SBI, SBN 15	
SB, SBI 1-8	232 Psi	SB 1-5	145 Psi	1-2	116 Psi
SB, SBI 9-12	362 Psi				
SBN 1-12	362 Psi	SBI 1-8	232 Psi	3-12	145 Psi
SB, SBI, SBN 20		SB, SBI 20		SB, SBI, SBN 20	
SB, SBI 1-7	232 Psi	SB 1-5	145 Psi	1	116 Psi
SB, SBI 8-10	362 Psi				
SBN 1-10	362 Psi	SBI 1-7	232 Psi	2-10	145 Psi
Stage	Max. Operating Pressure			Stage	Max. inlet Pressures
SB, SBI, SBN 32					
(1-1) -(5)	232 Psi			(1-1)-2	58 Psi
				(3-2)-6	145 Psi
(6-2)-(11-2)	435 Psi			(7-2)-(11-2)	217 Psi
SB, SBI, SBN 45					
(1-1) -(4-2)	232 Psi			(1-1)-1	58 Psi
				(2-2)-3	145 Psi
(4-1)-(8-1)	435 Psi			(4-2)-(8-1)	217 Psi
SB, SBI, SBN 64					
(1-1) -3	232 Psi			(1-1)	58 Psi
				1-(2-1)	145 Psi
(4-2)-(5-2)	435 Psi			2-(5-2)	217 Psi
SB, SBI, SBN 90					
(1-1) -3	232 Psi			(1-1)-1	145 Psi
(4-2) -(4-1)	435 Psi			(2-2)-(4-1)	217 Psi
SB, SBI, SBN 120					
(1-1) -(5-2)	435 Psi			(1-1)-1	145 Psi
				(2-2)-3	217 Psi
				(4-2)-(5-2)	290 Psi
SB, SBI, SBN 150					
(1-1) -(4-1)	435 Psi			(1-1)	145 Psi
				1-2	217 Psi
				(3-2)-(4-1)	290 Psi

*Rule to follow: The inlet pressure + the pressure against a closed valve < Max. Operating pressure.

Contents

Vertical Multistage Centrifugal In-line Pumps



Construction

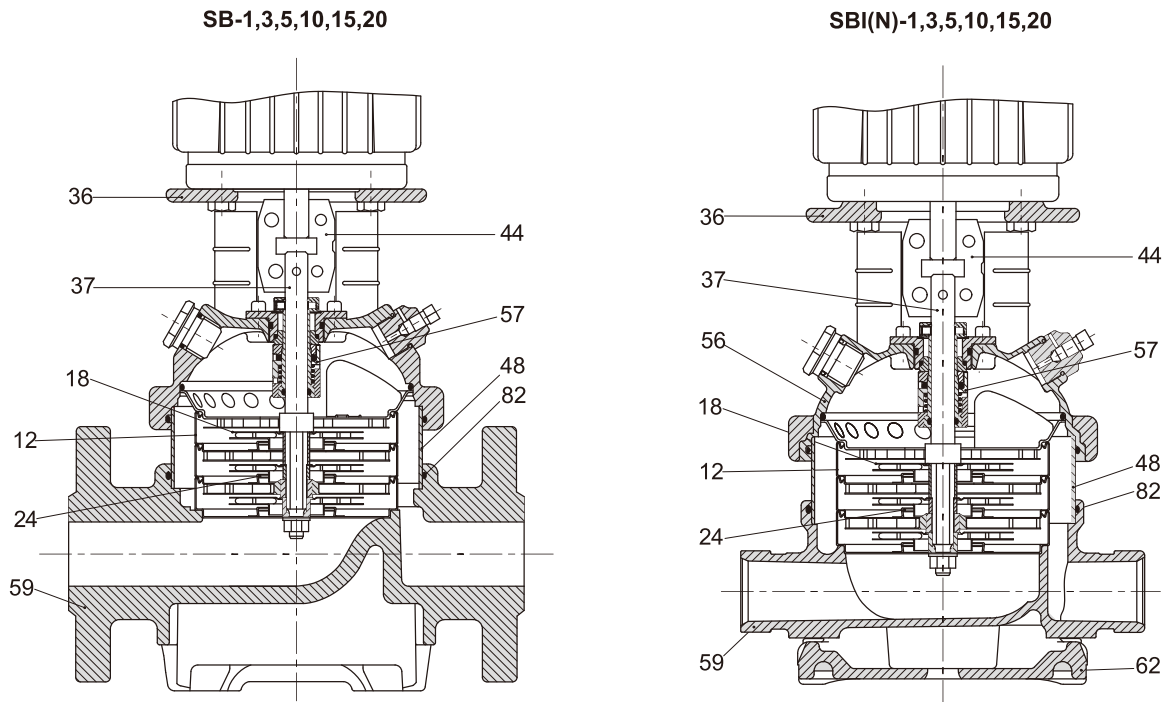

CONSTRUCTION

Pos.	Name	Material	SB 1,3,5,10,15,20	SBI 1,3,5,10,15,20	SBN 1,3,5,10,15,20
			Standard	Standard	Standard
			USA	USA	USA
36	Pump head	Cast Iron	ASTM 25B	ASTM 65-45-12	ASTM 65-45-12
56	Pump head cover	Stainless steel	N/A	AISI 304	AISI 316
18	Impeller	Stainless steel	AISI 304	AISI 304	AISI 316
37	Shaft	Stainless steel	AISI 431	AISI 431	AISI 316
48	Outer sleeve	Stainless steel	AISI 304	AISI 304	AISI 316
82	O-ring for outer sleeve	EPDM			
12	Chamber	Stainless steel	AISI 304	AISI 304	AISI 316
24	Neck ring	PTFE			
59	Base	Cast Iron	ASTM 35B	N/A	
		Stainless steel	N/A	AISI 304	AISI 316
62	Base plate	Cast Iron		ASTM 25B	ASTM 25B
44	coupling	Sintered metal			
57	Mechanical seal	Cartridge type			

Contents

Vertical Multistage Centrifugal In-line Pumps



Construction

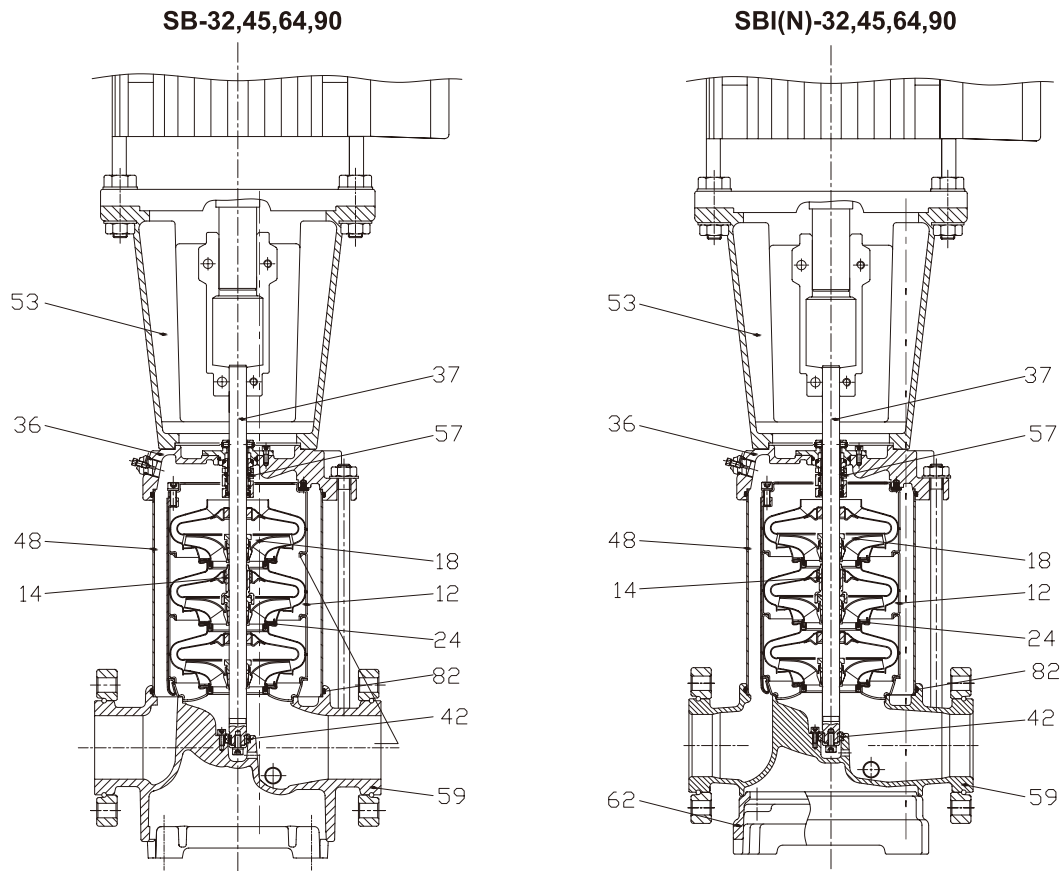

CONSTRUCTION

Pos.	Name	Material	SB 32,45,64,90	SBI 32,45,64,90	SBN 32,45,64,90
			Standard	Standard	Standard
			USA	USA	USA
36	Pump head	Cast Iron	ASTM 35B		
		Stainless steel		AISI 304	AISI 316
53	Motor Bracket	Cast Iron	ASTM 35B	ASTM 35B	ASTM 35B
18	Impeller	Stainless steel	AISI 304	AISI 304	AISI 316
37	Shaft	Stainless steel	AISI 431	AISI 431	AISI 316
48	Outer sleeve	Stainless steel	AISI 304	AISI 304	AISI 316
82	O-ring for outer sleeve	EPDM			
12	Chamber	Stainless steel	AISI 304	AISI 304	AISI 316
24	Neck ring	Carbon Fiber+ POB+PTFE			
59	Base	Cast Iron	ASTM 35B	N/A	
		Stainless steel	N/A	AISI 304	AISI 316
62	Base plate	Cast Iron	N/A	ASTM 35B	ASTM 35B
57	Mechanical seal	Cartridge type			
14	Bearing ring		Bronze		POB+Graphite+PTFE
42	Bottom bearing ring	Tungsten carbide/ Tungsten carbide			

Contents

Vertical Multistage Centrifugal In-line Pumps



SB-120,150

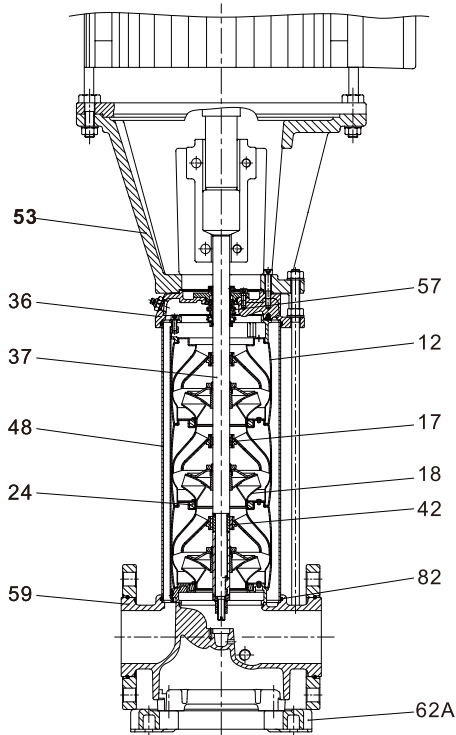

SBI/N-120,150

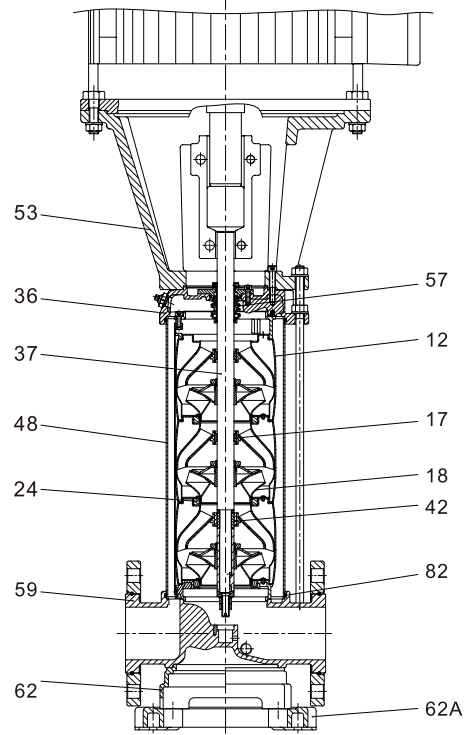

CONSTRUCTION

Pos.	Name	Material	SB 120,150	SBI 120,150	SBN 120,150
			Standard	Standard	Standard
			USA	USA	USA
36	Pump head	Cast Iron	ASTM 35B	N/A	
		Stainless steel	N/A	AISI 304	AISI 316
53	Motor Bracket (15HP~60HP)	Cast Iron	ASTM 35B	ASTM 35B	ASTM 35B
	Motor Bracket (75HP~100HP)	Cast Iron	ASTM 65-45-12	ASTM 65-45-12	ASTM 65-45-12
17	Bearing ring	PTFE			
18	Impeller	Stainless steel	AISI 304	AISI 304	AISI 316
37	Shaft	Stainless steel	AISI 431	AISI 431	AISI 316
48	Outer sleeve	Stainless steel	AISI 304	AISI 304	AISI 316
82	O-ring for outer sleeve	EPDM			
12	Chamber	Stainless steel	AISI 304	AISI 304	AISI 316
24	Neck ring	PTFE			
59	Base	Cast Iron	ASTM 35B	N/A	
		Stainless steel	N/A	AISI 304	AISI 316
62	Base plate	Cast Iron	N/A	ASTM 65-45-12	ASTM 65-45-12
62A	Base plate	Cast Iron	ASTM 65-45-12	ASTM 65-45-12	ASTM 65-45-12
57	Mechanical seal	Cartridge type			
42	Bottom bearing ring	SiC / SiC			

Contents

Vertical Multistage Centrifugal In-line Pumps



SB, SBI, SBN 1

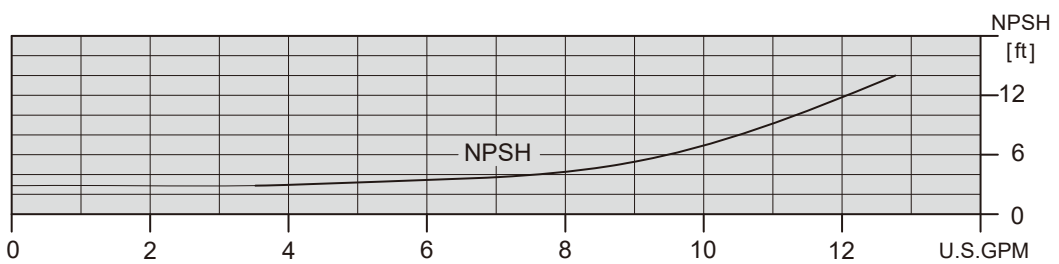
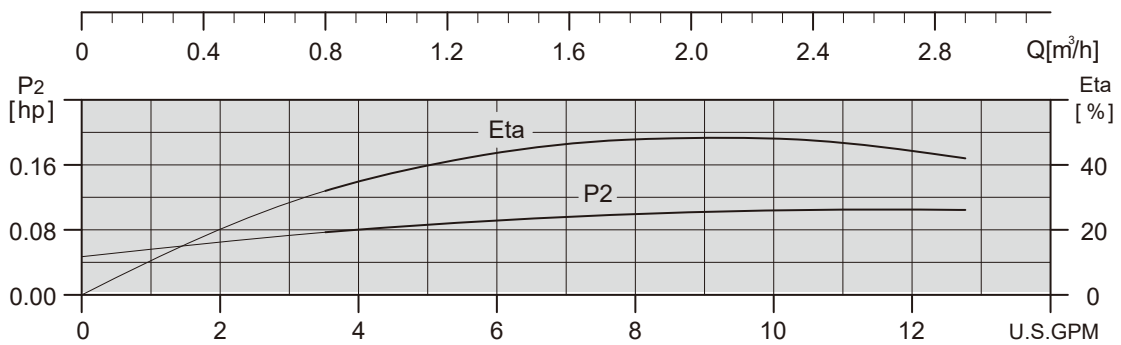
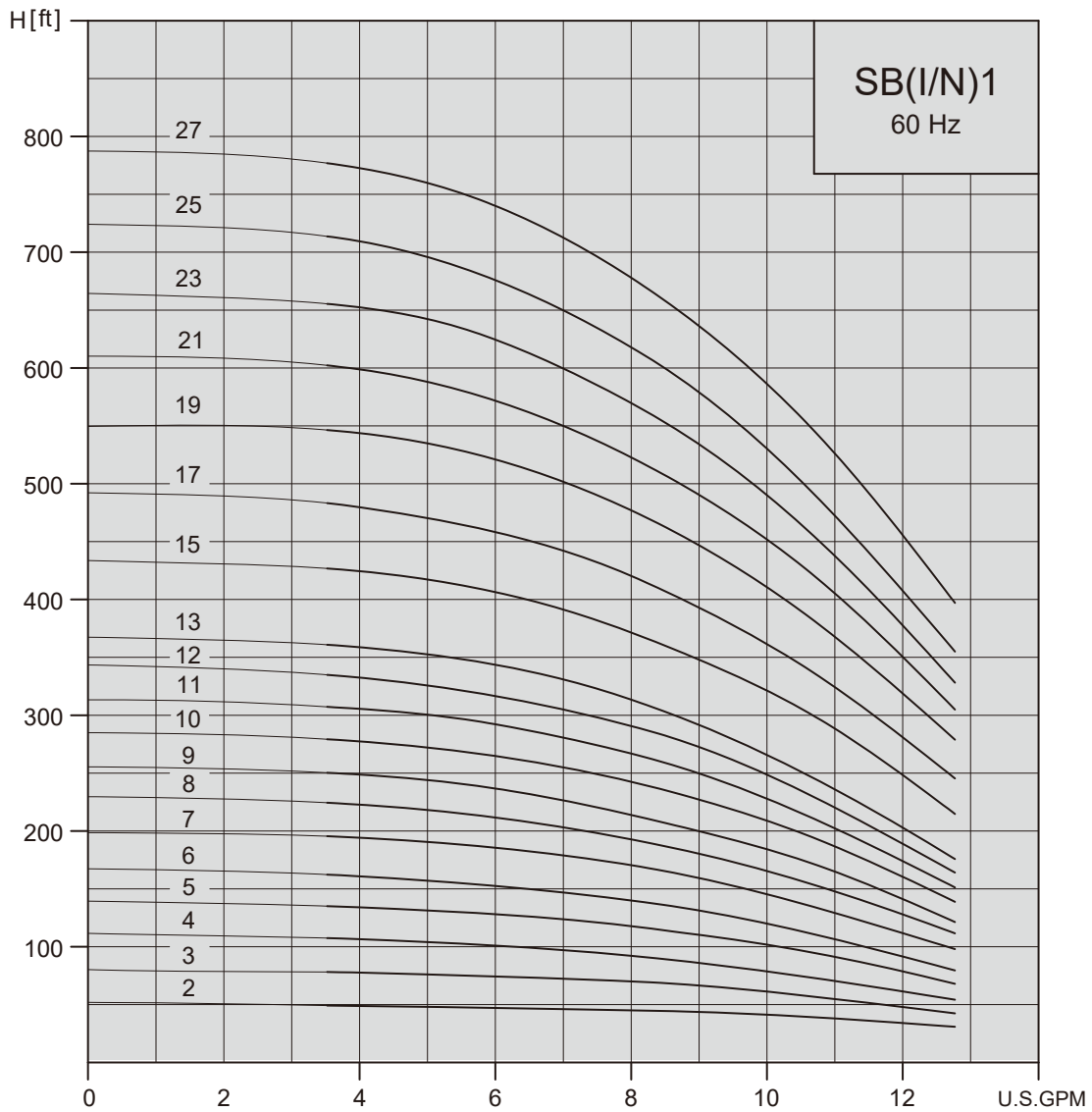

Contents

Vertical Multistage Centrifugal In-line Pumps



Dimension and weights-SB 1

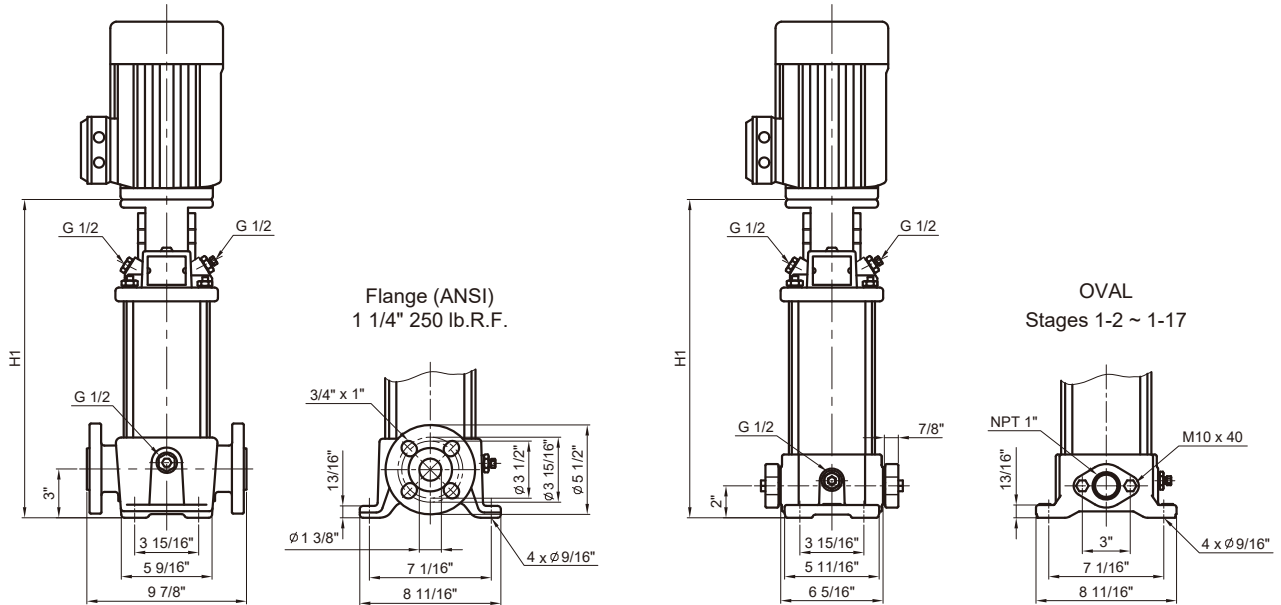

Pump type	Recommend motor of HP			NEMA Frame TEFC motors	SB			
	P ₂				Dimension[inch]		Weights[lbs]	
	[HP]	[kW]	[Ph]		ANSI flange	OVAL	ANSI flange	OVAL
				H1	H1			
SB1-2	1/3	0.25	1 / 3	56C	11.93	10.94	40.6	31.3
SB1-3	1/3	0.25	1 / 3	56C	11.93	10.94	40.6	31.4
SB1-4	1/2	0.37	1 / 3	56C	12.64	11.65	41.5	32.2
SB1-5	1/2	0.37	1 / 3	56C	13.35	12.36	42.2	33.0
SB1-6	3/4	0.55	1 / 3	56C	14.06	13.07	43.0	33.8
SB1-7	3/4	0.55	1 / 3	56C	14.76	13.78	43.8	34.5
SB1-8	1	0.75	1 / 3	56C	15.47	14.49	44.6	35.3
SB1-9	1	0.75	1 / 3	56C	16.18	15.20	45.4	36.1
SB1-10	1	0.75	1 / 3	56C	16.89	15.91	46.2	37.0
SB1-11	1 1/2	1.1	1 / 3	56C	17.60	16.61	47.0	37.8
SB1-12	1 1/2	1.1	1 / 3	56C	18.31	17.32	47.8	38.6
SB1-13	1 1/2	1.1	1 / 3	56C	19.02	18.03	48.6	39.4
SB1-15	2	1.5	1 / 3	56C	20.43	19.45	50.1	40.9
SB1-17	2	1.5	1 / 3	56C	21.85	20.87	51.7	42.4
SB1-19	2	1.5	1 / 3	56C	23.27	-	53.3	-
SB1-21	3	2.2	1 / 3	182TC	25.63	-	60.8	-
SB1-23	3	2.2	1 / 3	182TC	27.05	-	62.4	-
SB1-25	3	2.2	1 / 3	182TC	28.46	-	63.9	-
SB1-27	3	2.2	1 / 3	182TC	29.84	-	65.5	-

Contents

Vertical Multistage Centrifugal In-line Pumps



Dimension and weights-SBI 1

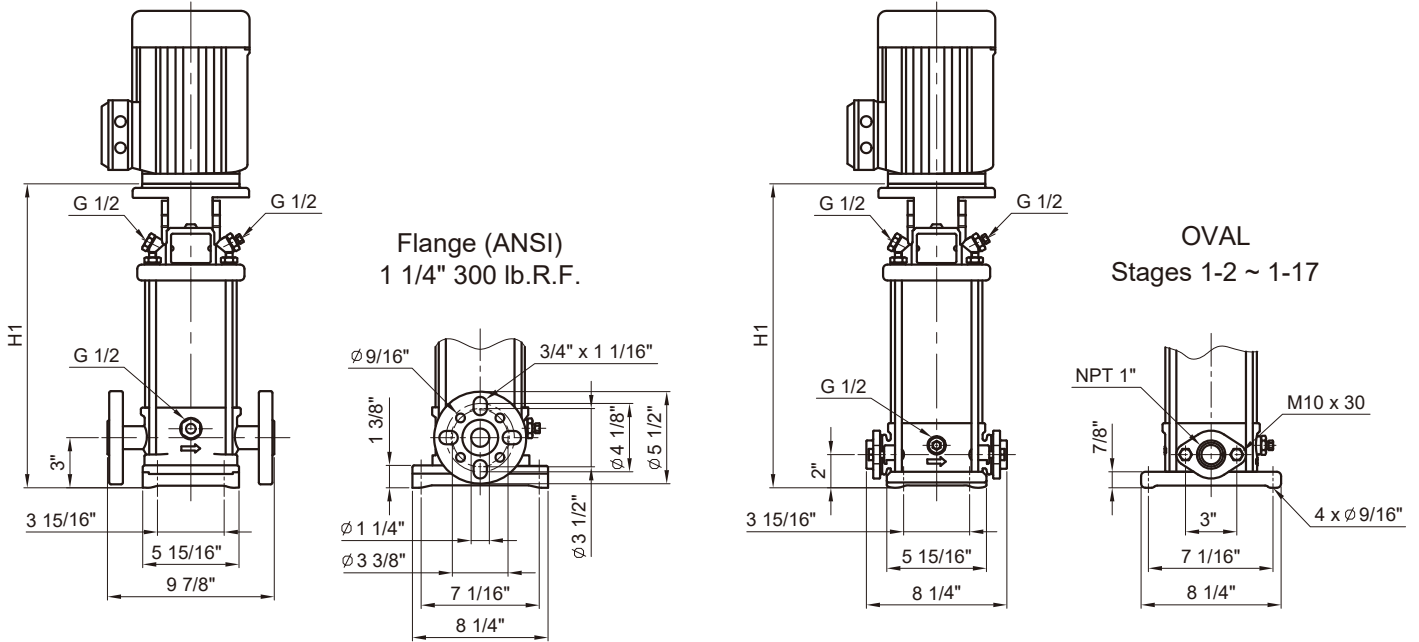

Pump type	Recommend motor of HP			NEMA Frame TEFC motors	SBI			
	P ₂				Dimension[inch]		Weights[lbs]	
	[HP]	[kW]	[PH]		ANSI flange	OVAL	ANSI flange	OVAL
				H1	H1			
SBI 1-2	1/3	0.25	1 / 3	56C	12.05	11.06	33.1	30.3
SBI 1-3	1/3	0.25	1 / 3	56C	12.05	11.06	33.2	30.4
SBI 1-4	1/2	0.37	1 / 3	56C	12.76	11.77	34.1	31.2
SBI 1 -5	1/2	0.37	1 / 3	56C	13.46	12.48	34.8	32.0
SBI 1-6	3/4	0.55	1 / 3	56C	14.17	13.19	35.6	32.8
SBI 1-7	3/4	0.55	1 / 3	56C	14.84	13.86	36.4	33.6
SBI 1-8	1	0.75	1 / 3	56C	15.55	14.57	37.2	34.4
SBI 1-9	1	0.75	1 / 3	56C	16.26	15.28	38.0	35.1
SBI 1-10	1	0.75	1 / 3	56C	16.97	15.98	38.8	35.9
SBI 1-11	1 1/2	1.1	1 / 3	56C	17.68	16.69	39.6	36.8
SBI 1-12	1 1/2	1.1	1 / 3	56C	18.39	17.40	40.4	37.6
SBI 1-13	1 1/2	1.1	1 / 3	56C	19.09	18.11	41.2	38.4
SBI 1-15	2	1.5	1 / 3	56C	20.55	19.57	42.7	39.9
SBI 1-17	2	1.5	1 / 3	56C	21.97	20.98	44.3	41.5
SBI 1-19	2	1.5	1 / 3	56C	23.39	-	45.8	-
SBI 1-21	3	2.2	1 / 3	182TC	25.73	-	53.4	-
SBI 1-23	3	2.2	1 / 3	182TC	27.15	-	55.1	-
SBI 1-25	3	2.2	1 / 3	182TC	28.56	-	56.5	-
SBI 1-27	3	2.2	1 / 3	182TC	29.98	-	58.1	-

Contents

Vertical Multistage Centrifugal In-line Pumps



Dimension and weights-SBN 1

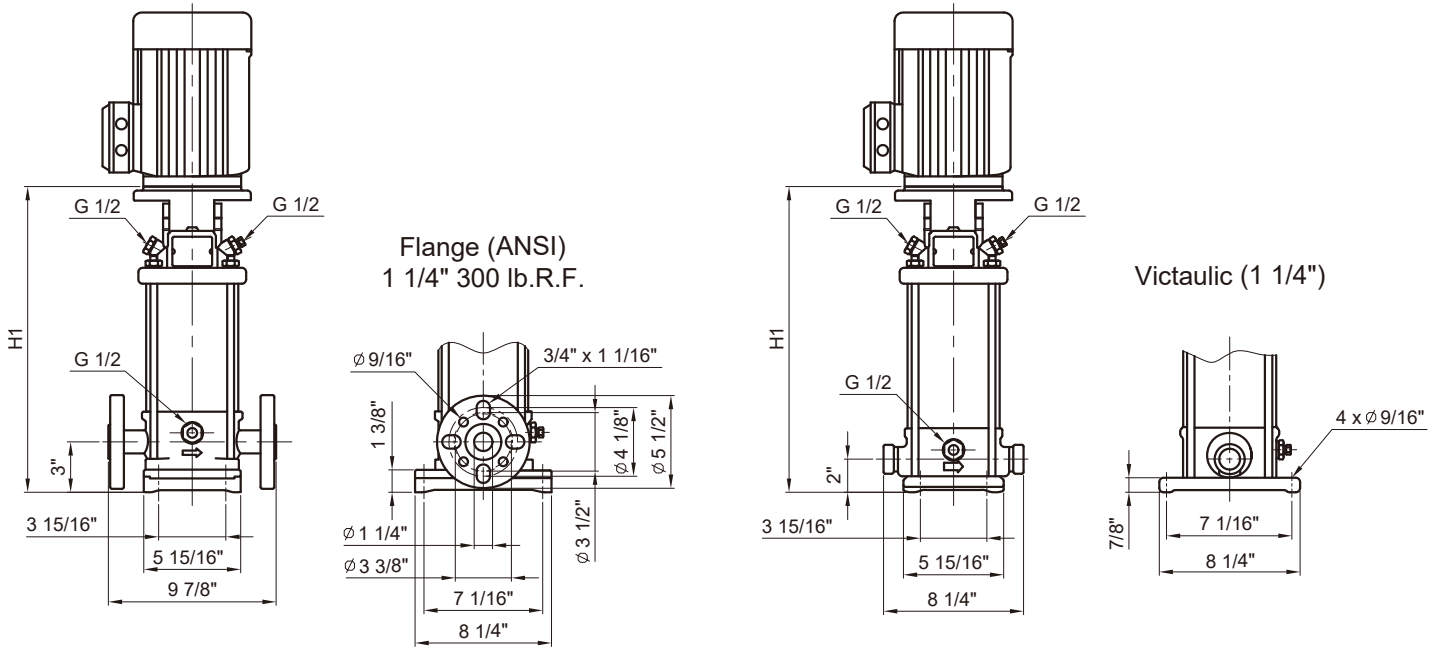

Pump type	Recommend motor of HP			NEMA Frame TEFC motors	SBN			
	P ₂				Dimension[inch]		Weights[lbs]	
	[HP]	[kW]	[PH]		ANSI flange	Victaulic	ANSI flange	Victaulic
				H1	H1			
SBN1-2	1/3	0.25	1 / 3	56C	12.05	11.06	33.1	31.1
SBN1-3	1/3	0.25	1 / 3	56C	12.05	11.06	33.2	31.2
SBN1-4	1/2	0.37	1 / 3	56C	12.76	11.77	34.1	32.0
SBN1-5	1/2	0.37	1 / 3	56C	13.46	12.48	34.8	32.8
SBN1-6	3/4	0.55	1 / 3	56C	14.17	13.19	35.6	33.6
SBN1-7	3/4	0.55	1 / 3	56C	14.84	13.86	36.4	34.3
SBN1-8	1	0.75	1 / 3	56C	15.55	14.57	37.2	35.1
SBN1-9	1	0.75	1 / 3	56C	16.26	15.28	38.0	35.9
SBN1-10	1	0.75	1 / 3	56C	16.97	15.98	38.8	36.7
SBN1-11	1 1/2	1.1	1 / 3	56C	17.68	16.69	39.6	37.6
SBN1-12	1 1/2	1.1	1 / 3	56C	18.39	17.40	40.4	38.4
SBN1-13	1 1/2	1.1	1 / 3	56C	19.09	18.11	41.2	39.2
SBN1-15	2	1.5	1 / 3	56C	20.55	19.57	42.7	40.7
SBN1-17	2	1.5	1 / 3	56C	21.97	20.98	44.3	42.3
SBN1-19	2	1.5	1 / 3	56C	23.39	22.40	45.8	43.8
SBN1-21	3	2.2	1 / 3	182TC	25.73	24.74	53.4	51.4
SBN1-23	3	2.2	1 / 3	182TC	27.15	26.16	55.1	53.0
SBN1-25	3	2.2	1 / 3	182TC	28.56	27.58	56.5	54.5
SBN1-27	3	2.2	1 / 3	182TC	29.98	29.00	58.1	56.1

Contents

Vertical Multistage Centrifugal In-line Pumps



SB, SBI, SBN 3

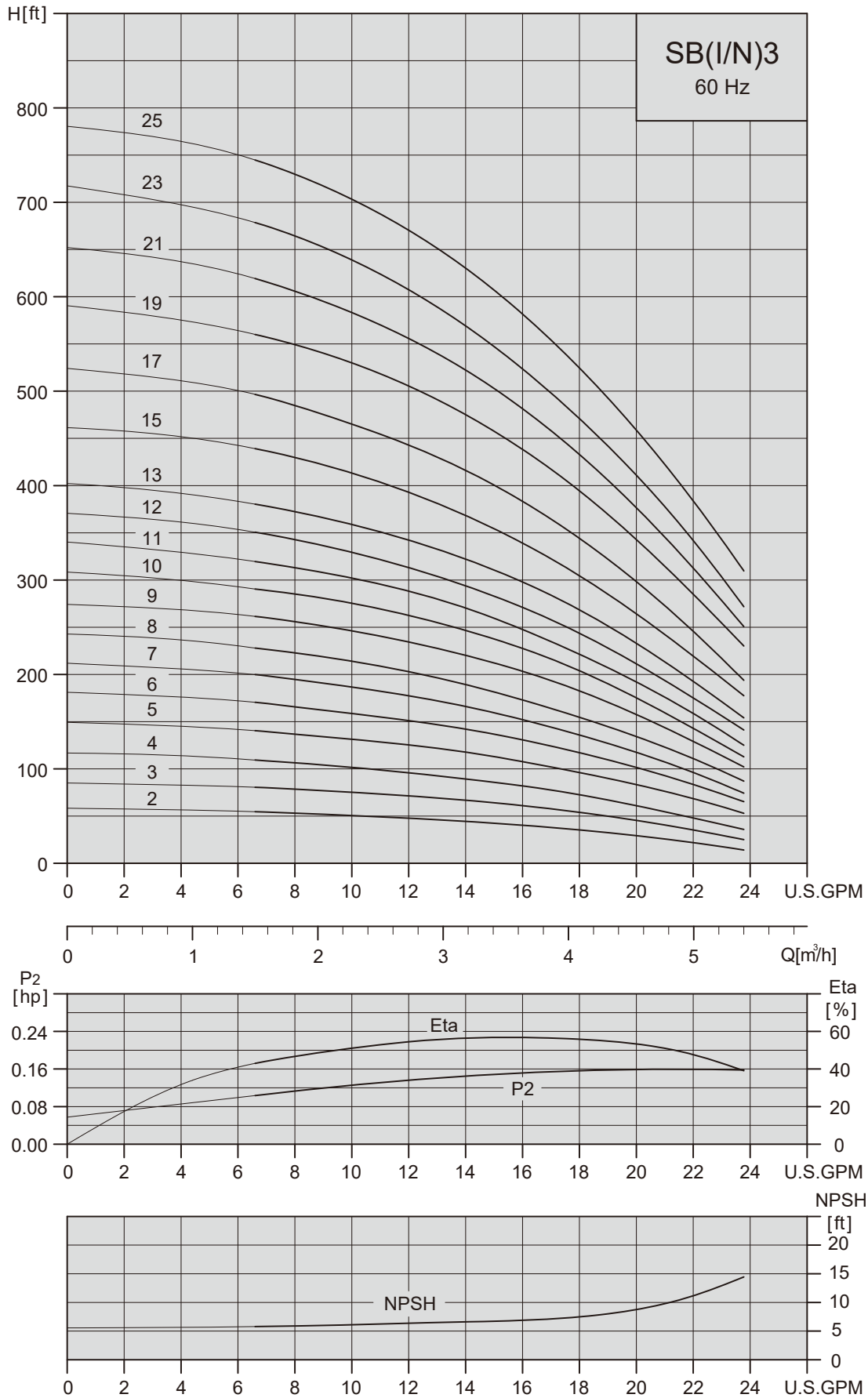

Contents

Vertical Multistage Centrifugal In-line Pumps



Dimension and weights-SB 3

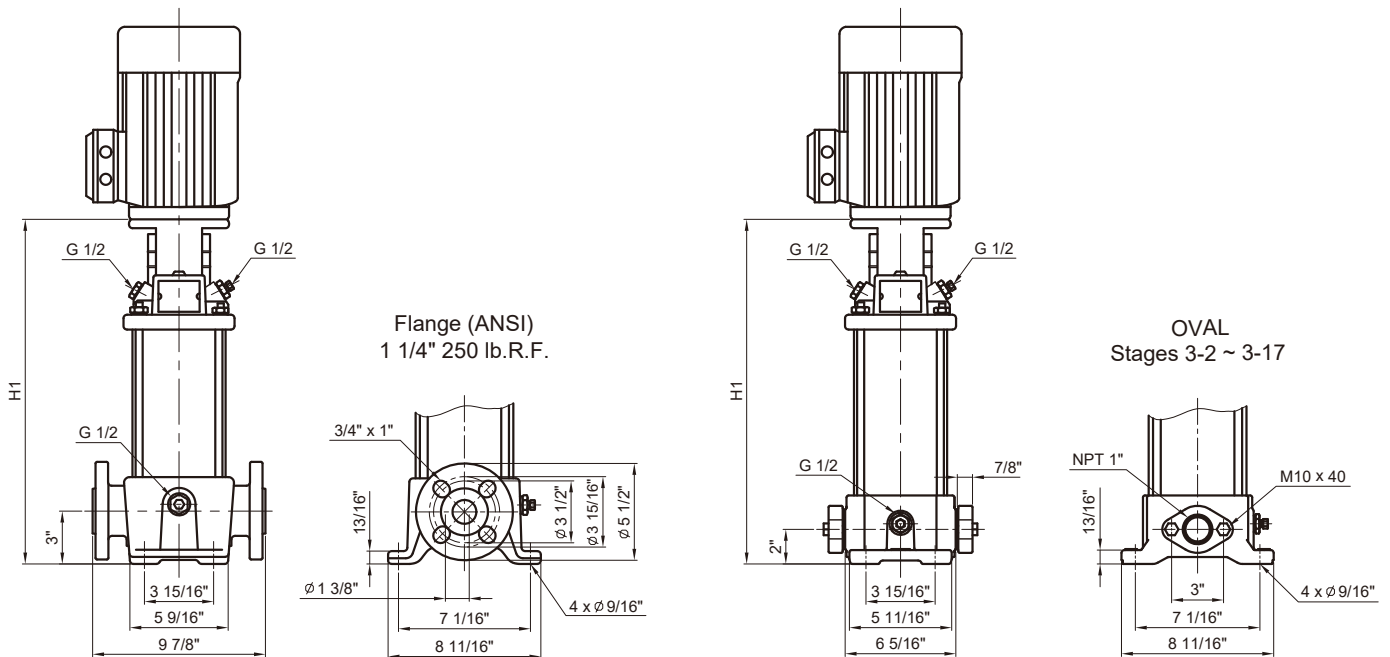

Pump type	Recommend Motor of HP		NEMA Frame TEFC motors	SB			
	P2			Dimension[inch]		Weights[lbs]	
	[HP]	[Ph]		ANSI flange	OVAL	ANSI flange	OVAL
			H1	H1			
SB 3-2	1/3	1 / 3	56C	11.93	10.94	40.6	31.3
SB 3-3	1/2	1 / 3	56C	11.93	10.94	40.6	31.4
SB 3-4	3/4	1 / 3	56C	12.64	11.65	41.5	32.2
SB 3-5	3/4	1 / 3	56C	13.35	12.36	42.2	33.0
SB 3-6	1	1 / 3	56C	14.06	13.07	43.0	33.8
SB 3-7	1 1/2	1 / 3	56C	14.76	13.78	43.8	34.5
SB 3-8	1 1/2	1 / 3	56C	15.47	14.49	44.6	35.3
SB 3-9	1 1/2	1 / 3	56C	16.18	15.20	45.4	36.1
SB 3-10	2	1 / 3	56C	16.89	15.91	46.2	37.0
SB 3-11	2	1 / 3	56C	17.60	16.61	47.0	37.8
SB 3-12	2	1 / 3	56C	18.31	17.32	47.8	38.6
SB 3-13	3	1 / 3	182TC	19.96	18.98	54.5	45.3
SB-3-15	3	1 / 3	182TC	21.38	20.39	56.0	46.8
SB-3-17	3	1 / 3	182TC	22.80	21.81	57.6	48.4
SB-3-19	3	1 / 3	182TC	24.17	-	59.2	-
SB-3-21	5	1	213TC	26.18	-	65.7	-
		3	182TC	25.59	-	60.8	-
SB-3-23	5	1	213TC	27.60	-	67.3	-
		3	182TC	27.01	-	62.4	-
SB-3-25	5	1	213TC	29.02	-	68.8	-
		3	182TC	28.43	-	63.9	-

Contents

Vertical Multistage Centrifugal In-line Pumps



Dimension and weights-SBI 3

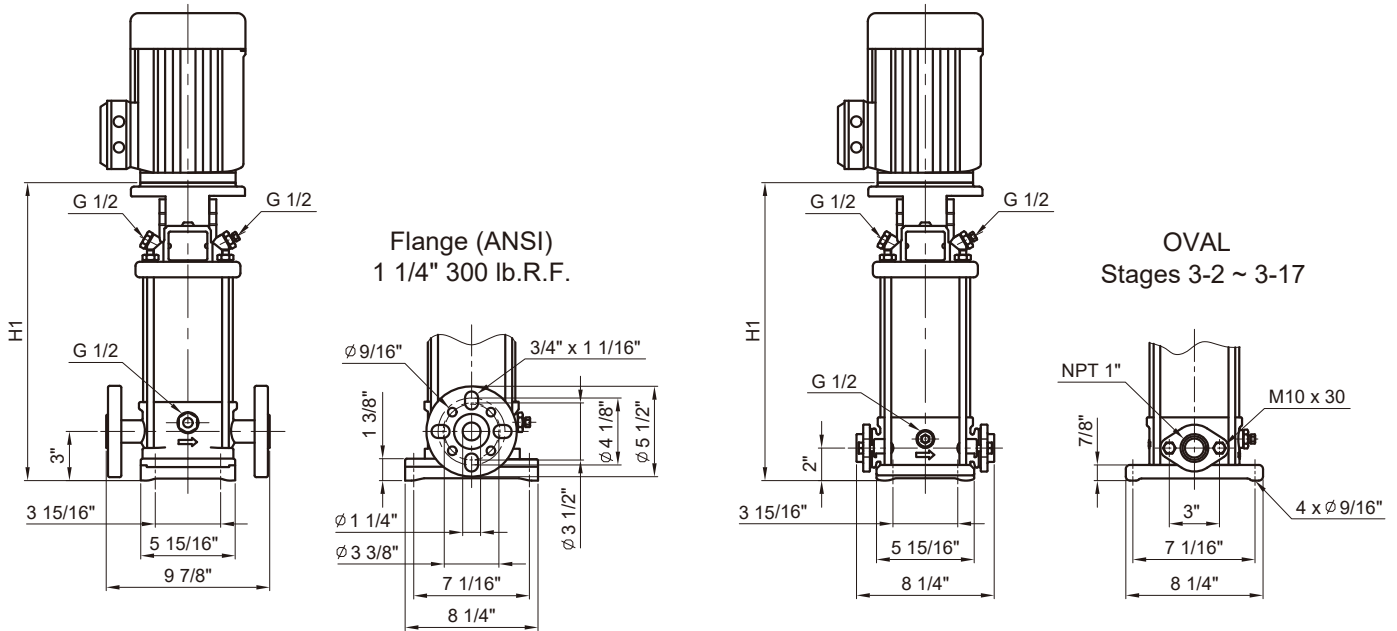

Pump type	Recommend Motor of HP		NEMA Frame TEFC motors	SBI			
	P ₂			Dimension[inch]		Weights[lbs]	
	[HP]	[Ph]		ANSI flange	OVAL	ANSI flange	OVAL
				H1	H1		
SBI 3-2	1/3	1 / 3	56C	12.05	11.06	33.1	30.3
SBI 3-3	1/2	1 / 3	56C	12.05	11.06	33.2	30.4
SBI 3-4	3/4	1 / 3	56C	12.76	11.77	34.1	31.2
SBI 3-5	3/4	1 / 3	56C	13.43	12.44	34.8	32.0
SBI 3-6	1	1 / 3	56C	14.13	13.15	35.6	32.8
SBI 3-7	1 1/2	1 / 3	56C	14.84	13.86	36.4	33.6
SBI 3-8	1 1/2	1 / 3	56C	15.55	14.57	37.2	34.4
SBI 3-9	1 1/2	1 / 3	56C	16.30	15.31	38.0	35.1
SBI 3-10	2	1 / 3	56C	17.01	16.02	38.8	35.9
SBI 3-11	2	1 / 3	56C	17.72	16.73	39.6	36.8
SBI 3-12	2	1 / 3	56C	18.43	17.44	40.4	37.6
SBI 3-13	3	1 / 3	182TC	20.06	19.07	47.2	44.4
SBI 3-15	3	1 / 3	182TC	21.48	20.49	48.6	45.8
SBI 3-17	3	1 / 3	182TC	22.89	21.91	50.2	47.4
SBI 3-19	3	1 / 3	182TC	24.50	-	51.8	-
SBI 3-21	5	1	213TC	26.32	-	58.3	-
		3	182TC	25.73	-	53.4	-
SBI 3-23	5	1	213TC	27.74	-	60.0	-
		3	182TC	27.15	-	55.1	-
SBI 3-25	5	1	213TC	29.15	-	61.4	-
		3	182TC	28.56	-	56.5	-

Contents

Vertical Multistage Centrifugal In-line Pumps



Dimension and weights-SBN 3

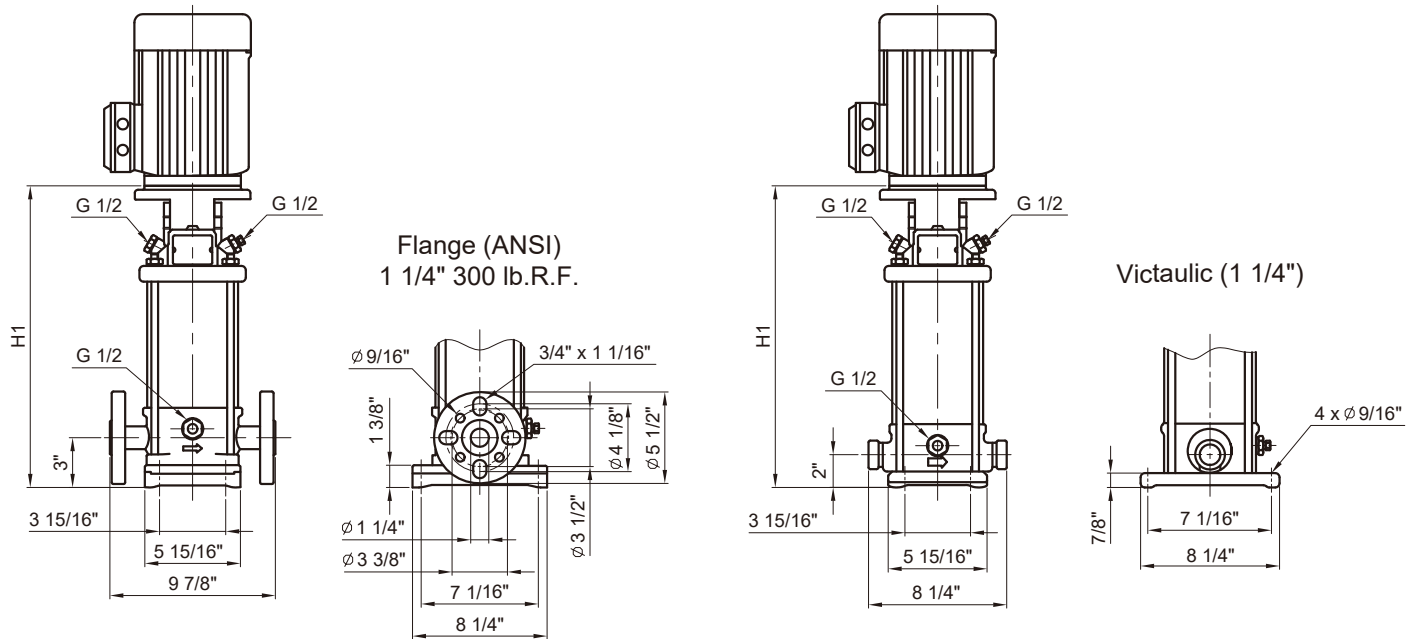

Pump type	Recommend Motor of HP		NEMA Frame TEFC motors	SBN			
	P 2			Dimension[inch]		Weights[lbs]	
	[HP]	[Ph]		ANSI flange	Victaulic	ANSI flange	Victaulic
SBN 3-2	1/3	1 / 3	56C	H1	H1		
SBN 3-3	1/2	1 / 3	56C	12.05	11.06	33.1	31.1
SBN 3-4	3/4	1 / 3	56C	12.76	11.77	34.1	32.0
SBN 3-5	3/4	1 / 3	56C	13.43	12.44	34.8	32.8
SBN 3-6	1	1 / 3	56C	14.13	13.15	35.6	33.6
SBN 3-7	1 1/2	1 / 3	56C	14.84	13.86	36.4	34.3
SBN 3-8	1 1/2	1 / 3	56C	15.55	14.57	37.2	35.1
SBN 3-9	1 1/2	1 / 3	56C	16.30	15.31	38.0	35.9
SBN 3-10	2	1 / 3	56C	17.01	16.02	38.8	36.7
SBN 3-11	2	1 / 3	56C	17.72	16.73	39.6	37.6
SBN 3-12	2	1 / 3	56C	18.43	17.44	40.4	38.4
SBN 3-13	3	1 / 3	182TC	20.06	19.07	47.2	45.1
SBN 3-15	3	1 / 3	182TC	21.48	20.49	48.6	46.6
SBN 3-17	3	1 / 3	182TC	22.89	21.91	50.2	48.2
SBN 3-19	3	1 / 3	182TC	24.50	23.50	51.8	49.7
SBN 3-21	5	1	213TC	26.32	25.33	58.3	56.3
		3	182TC	25.73	24.74	53.4	51.4
SBN 3-23	5	1	213TC	27.74	26.74	60.0	57.9
		3	182TC	27.15	26.16	55.1	53.0
SBN 3-25	5	1	213TC	29.15	28.17	61.4	59.4
		3	182TC	28.56	27.58	56.5	54.5

Contents

Vertical Multistage Centrifugal In-line Pumps



SB, SBI, SBN 5

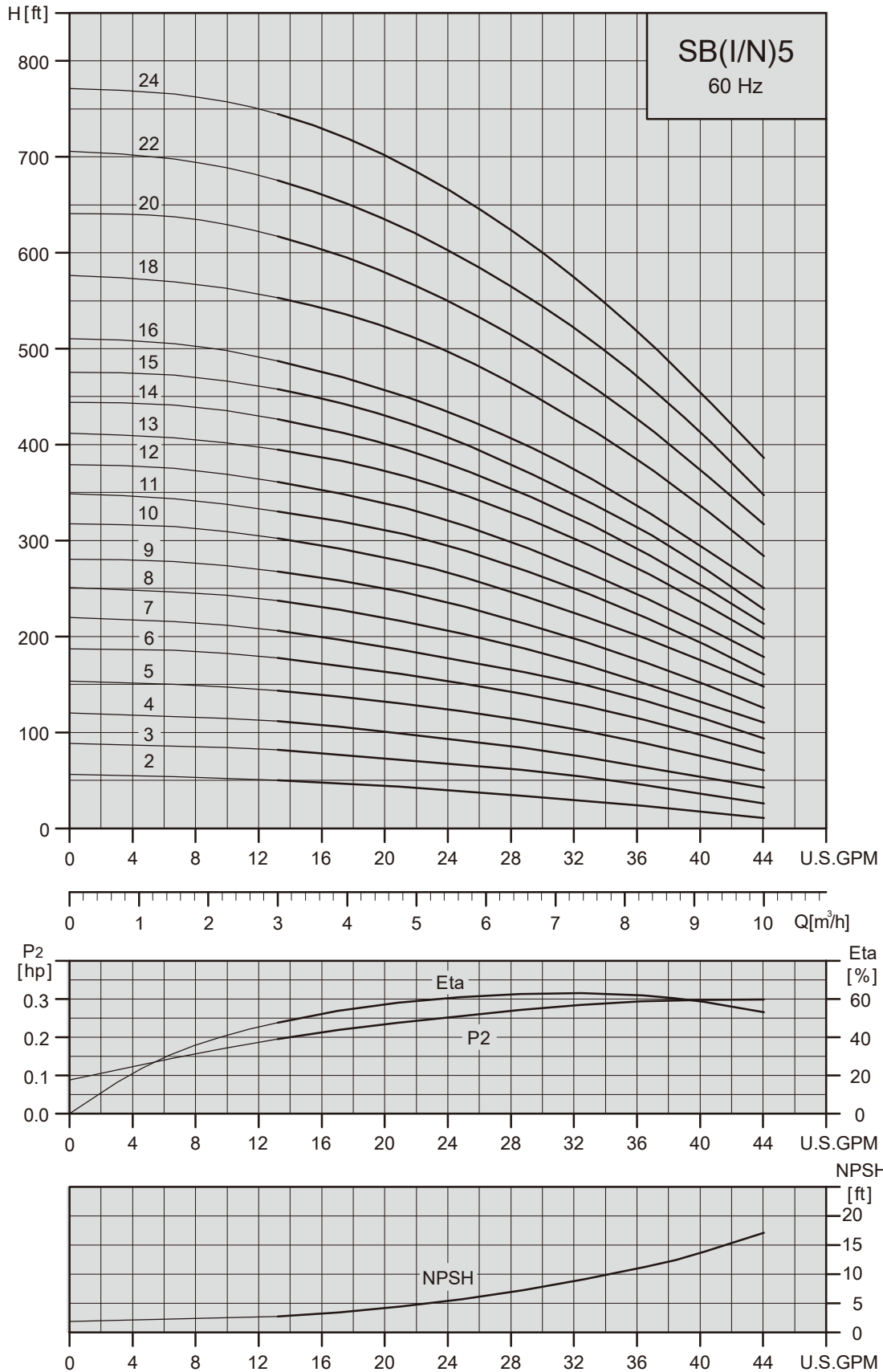

Contents

Vertical Multistage Centrifugal In-line Pumps



Dimension and weights-SB 5

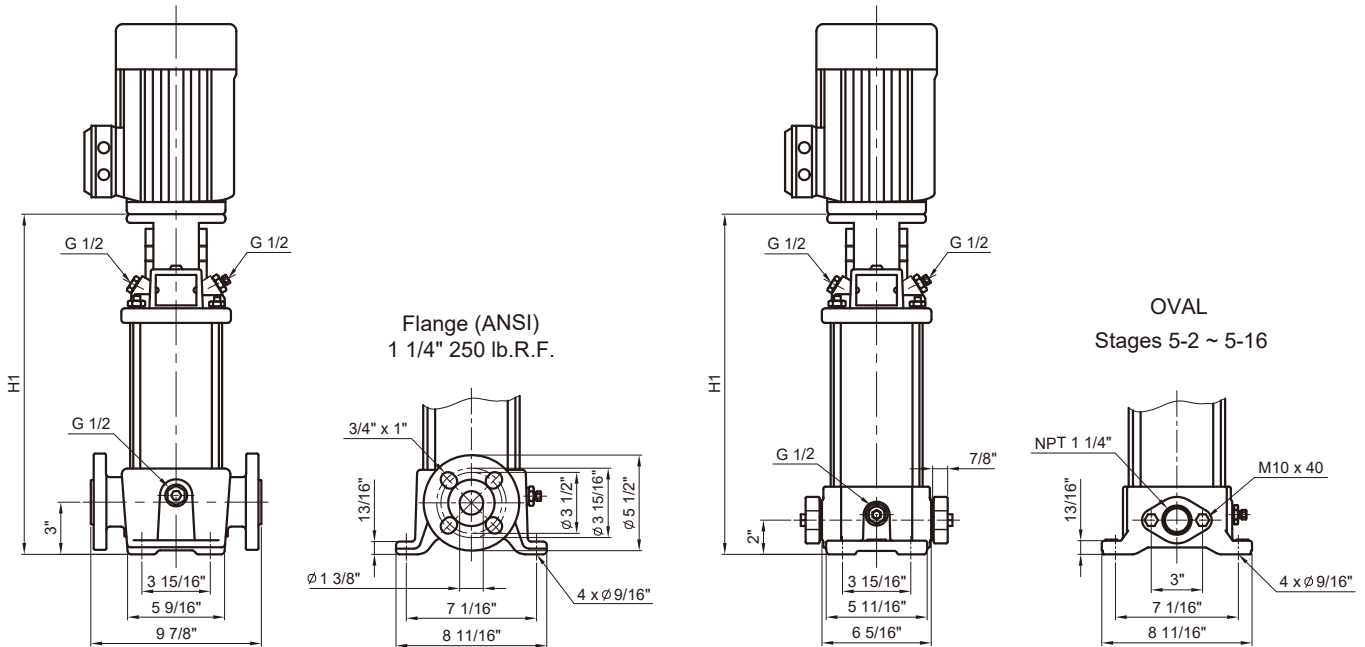

Pump type	Recommend Motor of HP		NEMA Frame TEFC motors	SB			
	P2			Dimension[inch]		Weights[lbs]	
	[HP]	[Ph]		ANSI flange	OVAL	ANSI flange	OVAL
				H1	H1		
SB5-2	3/4	1 / 3	56C	11.93	10.94	40.4	31.6
SB5-3	1	1 / 3	56C	12.99	12.01	41.3	32.5
SB5-4	1 1/2	1 / 3	56C	14.06	13.07	42.4	33.6
SB5-5	1 1/2	1 / 3	56C	15.12	14.30	43.5	34.7
SB5-6	2	1 / 3	56C	16.18	15.20	44.7	35.9
SB5-7	2	1 / 3	56C	17.24	16.26	45.7	36.9
SB5-8	3	1 / 3	182TC	19.25	18.27	52.8	44.0
SB5-9	3	1 / 3	182TC	20.31	19.33	53.9	45.1
SB5-10	3	1 / 3	182TC	21.34	20.35	55.0	46.3
SB5-11	5	1	213TC	22.99	22.01	61.1	52.3
		3	182TC	22.40	21.42	56.2	47.4
SB5-12	5	1	213TC	24.05	23.07	62.2	53.4
		3	182TC	23.46	22.48	57.3	48.5
SB5-13	5	1	213TC	25.12	24.13	63.3	54.5
		3	182TC	24.53	23.54	58.4	49.6
SB5-14	5	1	213TC	26.18	25.20	64.6	55.8
		3	182TC	25.59	24.61	59.7	50.9
SB5-15	5	1	213TC	27.24	26.26	65.3	56.5
		3	182TC	26.65	25.67	60.4	51.6
SB5-16	5	1	213TC	28.31	27.32	66.6	57.8
		3	182TC	27.72	26.73	61.7	52.9
SB5-18	7 1/2	1 / 3	213TC	30.47	-	69.2	-
SB5-20	7 1/2	1 / 3	213TC	32.60	-	71.8	-
SB5-22	7 1/2	1 / 3	213TC	34.72	-	73.7	-
SB5-24	7 1/2	1 / 3	213TC	36.85	-	75.9	-

* For the 5HP single phase TEFC motor, we provide 213TC Frame

Contents

Vertical Multistage Centrifugal In-line Pumps



Dimension and weights-SBI 5

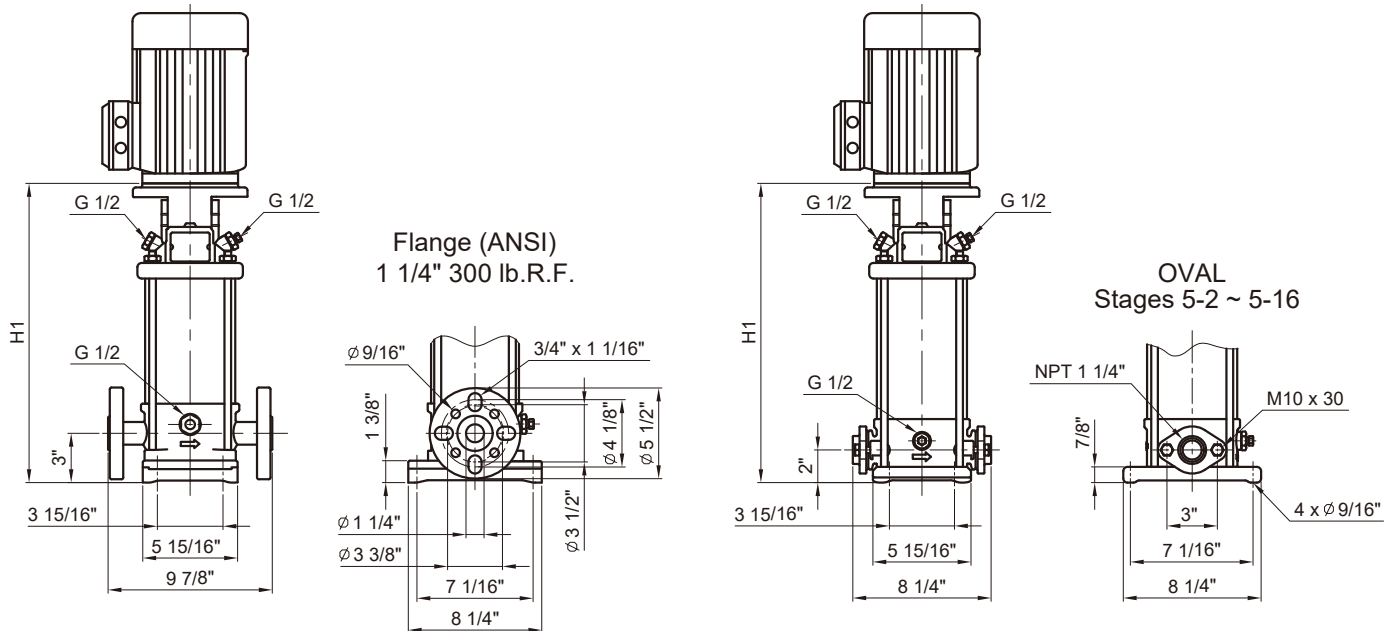

Pump type	Recommend Motor of HP		NEMA Frame TEFC motors	SBI			
	P 2			Dimension[inch]		Weights[lbs]	
	[HP]	[Ph]		ANSI flange	OVAL	ANSI flange	OVAL
			H1	H1			
SBI 5-2	3/4	1 / 3	56C	12.05	11.06	33.0	30.1
SBI 5-3	1	1 / 3	56C	13.07	12.09	34.3	31.5
SBI 5-4	1 1/2	1 / 3	56C	14.13	13.15	35.4	33.6
SBI 5-5	1 1/2	1 / 3	56C	15.24	14.25	36.6	34.7
SBI 5-6	2	1 / 3	56C	16.30	15.31	37.8	35.9
SBI 5-7	2	1 / 3	56C	17.36	16.38	38.9	37.0
SBI 5-8	3	1 / 3	182TC	19.35	18.37	45.9	44.1
SBI 5-9	3	1 / 3	182TC	20.41	19.43	47.1	45.2
SBI 5-10	3	1 / 3	182TC	21.50	20.50	48.4	46.5
SBI 5-11	5	1	213TC	23.09	22.19	54.4	52.5
		3	182TC	22.54	21.56	49.5	47.6
SBI 5-12	5	1	213TC	24.19	23.19	55.5	53.7
		3	182TC	23.60	22.62	50.6	48.8
SBI 5-13	5	1	213TC	25.29	24.29	56.7	54.9
		3	182TC	24.67	23.68	51.8	50.0
SBI 5-14	5	1	213TC	26.29	25.29	57.8	56.0
		3	182TC	25.73	24.74	52.9	51.1
SBI 5-15	5	1	213TC	27.39	26.39	59.1	57.2
		3	182TC	26.79	25.81	54.2	52.3
SBI 5-16	5	1	213TC	28.49	27.49	60.2	58.4
		3	182TC	27.85	26.90	55.3	53.5
SBI 5-18	7 1/2	1 / 3	213TC	30.57	-	62.9	-
SBI 5-20	7 1/2	1 / 3	213TC	32.70	-	65.6	-
SBI 5-22	7 1/2	1 / 3	213TC	34.82	-	67.4	-
SBI 5-24	7 1/2	1 / 3	213TC	36.95	-	69.7	-

* For the 5HP single phase TEFC motor, we provide 213TC Frame

Contents

Vertical Multistage Centrifugal In-line Pumps



Dimension and weights-SBN 5

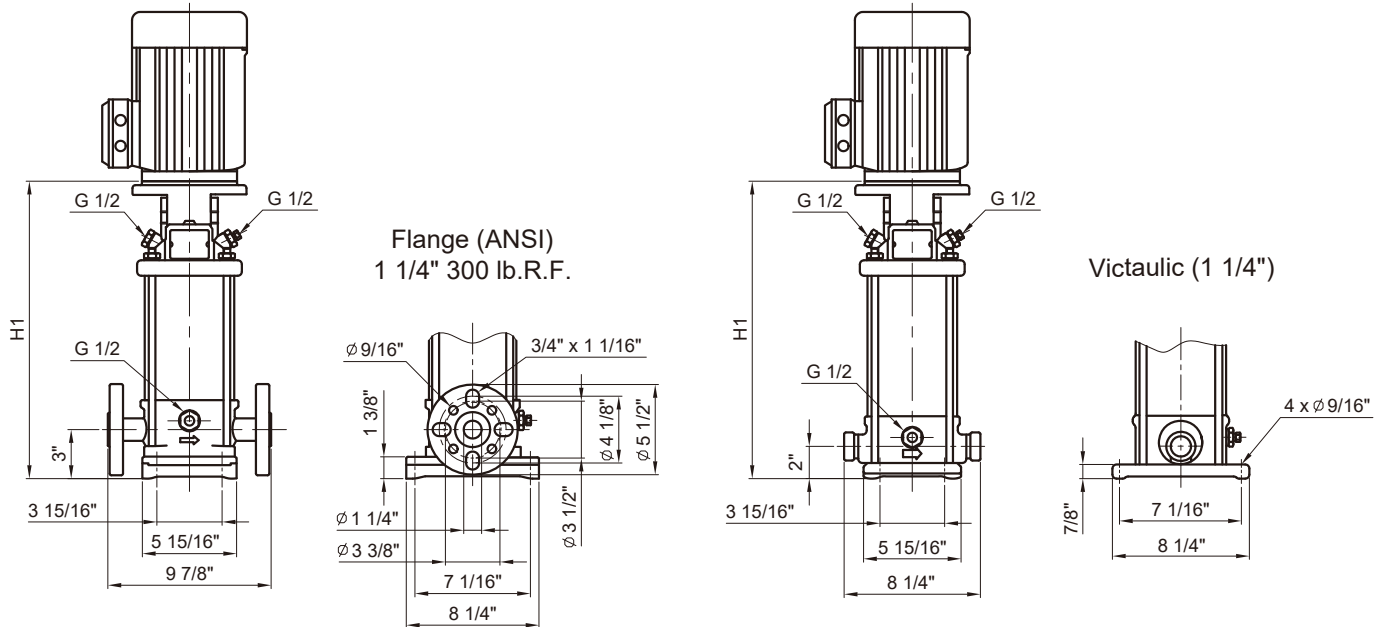

Pump type	Recommend Motor of HP		NEMA Frame TEFC motors	SBN			
	P ₂			Dimension[inch]		Weights[lbs]	
	[HP]	[Ph]		ANSI flange H1	Victaulic H1	ANSI flange	Victaulic
SBN 5-2	3/4	1 / 3	56C	12.05	11.06	33.0	30.9
SBN 5-3	1	1 / 3	56C	13.07	12.09	34.3	32.2
SBN 5-4	1 1/2	1 / 3	56C	14.13	13.15	35.4	33.4
SBN 5-5	1 1/2	1 / 3	56C	15.24	14.25	36.6	34.5
SBN 5-6	2	1 / 3	56C	16.30	15.31	37.8	35.8
SBN 5-7	2	1 / 3	56C	17.36	16.38	38.9	36.8
SBN 5-8	3	1 / 3	182TC	19.35	18.37	45.9	43.9
SBN 5-9	3	1 / 3	182TC	20.41	19.43	47.1	45.1
SBN 5-10	3	1 / 3	182TC	21.50	20.50	48.4	46.3
SBN 5-11	5	1	213TC	23.09	22.19	54.4	52.3
		3	182TC	22.54	21.56	49.5	47.4
SBN 5-12	5	1	213TC	24.19	23.19	55.5	53.5
		3	182TC	23.60	22.62	50.6	48.6
SBN 5-13	5	1	213TC	25.29	24.29	56.7	54.7
		3	182TC	24.67	23.68	51.8	49.8
SBN 5-14	5	1	213TC	26.29	25.29	57.8	55.8
		3	182TC	25.73	24.74	52.9	50.9
SBN 5-15	5	1	213TC	27.39	26.39	59.1	57.1
		3	182TC	26.79	25.81	54.2	52.2
SBN 5-16	5	1	213TC	28.49	27.49	60.2	58.2
		3	182TC	27.85	26.87	55.3	53.3
SBN 5-18	7 1/2	1 / 3	213TC	30.57	29.59	62.9	60.9
SBN 5-20	7 1/2	1 / 3	213TC	32.70	31.71	65.6	63.6
SBN 5-22	7 1/2	1 / 3	213TC	34.82	33.84	67.4	65.4
SBN 5-24	7 1/2	1 / 3	213TC	36.95	35.96	69.7	67.7

* For the 5HP single phase TEFC motor, we provide 213TC Frame

Contents

Vertical Multistage Centrifugal In-line Pumps



SB, SBI, SBN 10

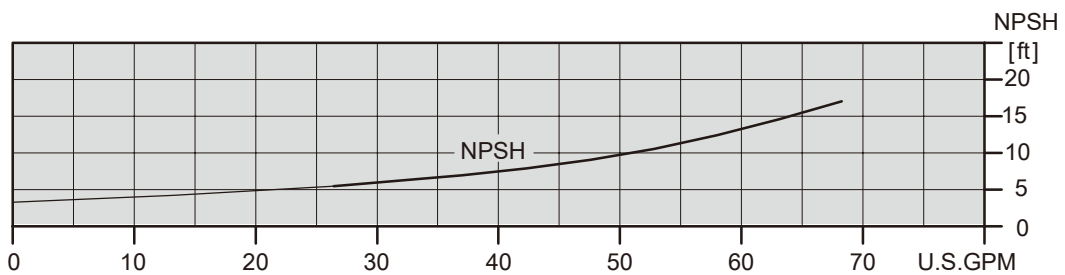
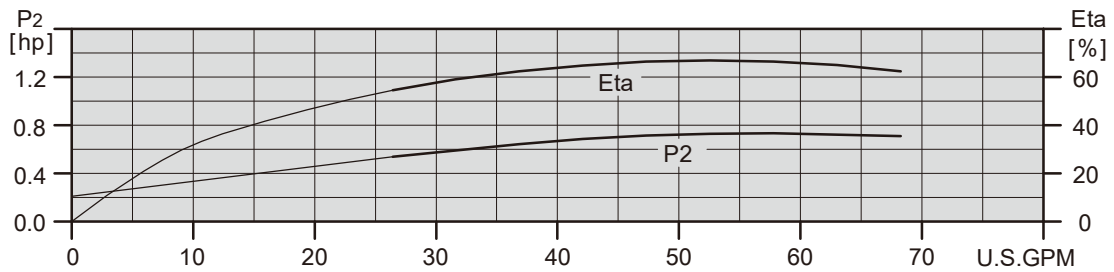
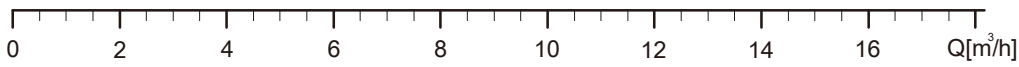
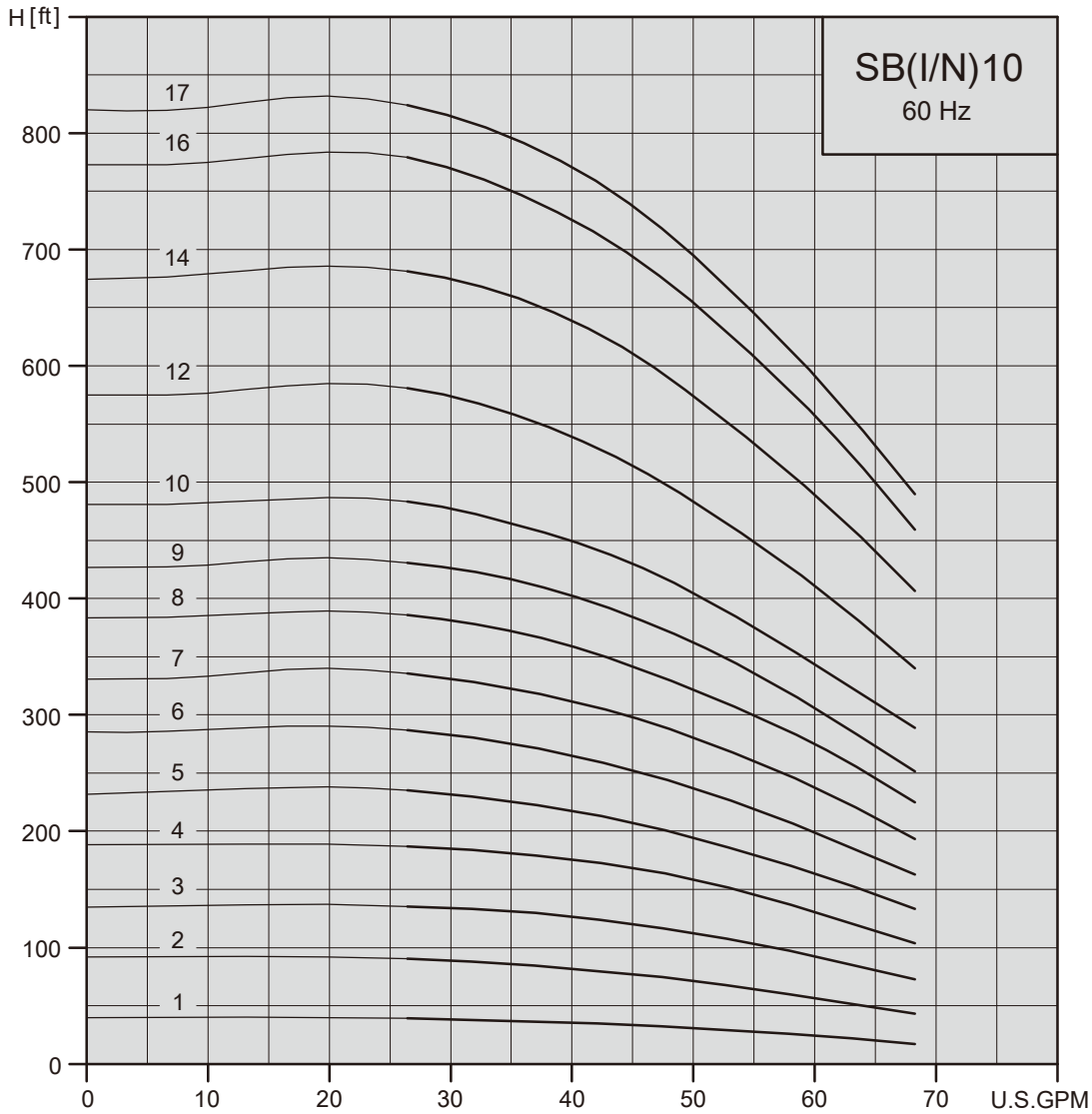

Contents

Vertical Multistage Centrifugal In-line Pumps

Dimension and weights-SB 10

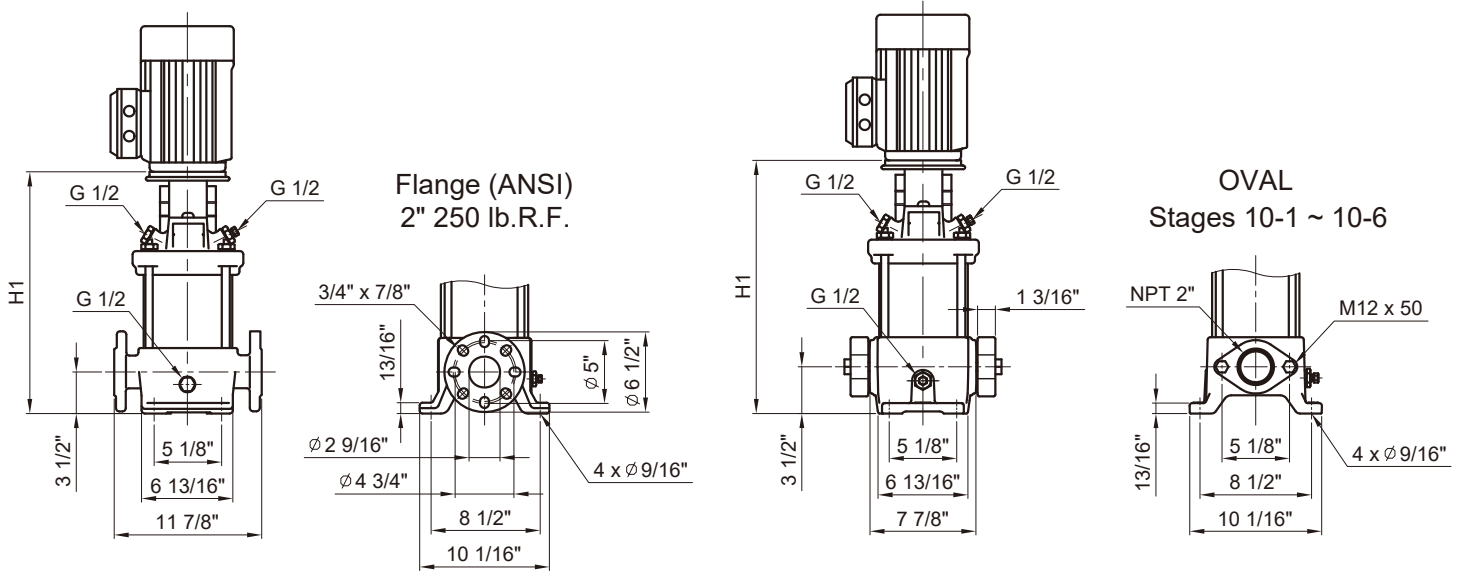

Pump type	Recommend Motor of HP		SB					
	P 2		NEMA Frame TEFC motors	NEMA Frame ODP motors	Dimension[inch]		Weights[lbs]	
	[HP]	[Ph]			HI		ANSI flange	OVAL
					ANSI flange	OVAL		
SB 10-1	3/4	1 / 3	56C	-	15.08	15.08	75.8	63.9
SB 10-2	1 1/2	1 / 3	56C	-	15.08	15.08	76.2	64.3
SB 10-3	3	1 / 3	182TC	-	17.20	17.20	92.1	80.2
SB 10-4	3	1 / 3	182TC	-	18.39	18.39	94.4	82.5
SB 10-5	5	1	213TC	-	20.16	20.16	101.5	89.6
		3	182TC	-	19.57	19.57	96.6	84.7
SB 10-6	5	1	213TC	-	21.34	21.34	103.7	91.7
		3	182TC	-	20.75	20.75	98.8	86.8
SB 10-7	5	1	213TC	-	22.50	-	105.9	-
		3	182TC	-	21.91	-	101.0	-
SB 10-8	7 1/2	1 / 3	213TC	-	23.68	-	110.4	-
SB 10-9	7 1/2	1 / 3	213TC	-	24.86	-	112.6	-
SB 10-10	7 1/2	1 / 3	213TC	-	26.04	-	114.8	-
SB 10-12	10	1 / 3	213TC	-	28.40	-	119.2	-
SB 10-14	10	1 / 3	213TC	-	30.80	-	123.7	-
SB 10-16	15	3	254TC	254TC	35.75	-	137.3	-
SB 10-17	15	3	254TC	254TC	36.93	-	139.5	-

* For the 5HP single phase TEFC motor, we provide 213TC Frame

Contents

Vertical Multistage Centrifugal In-line Pumps

Dimension and weights-SBI 10

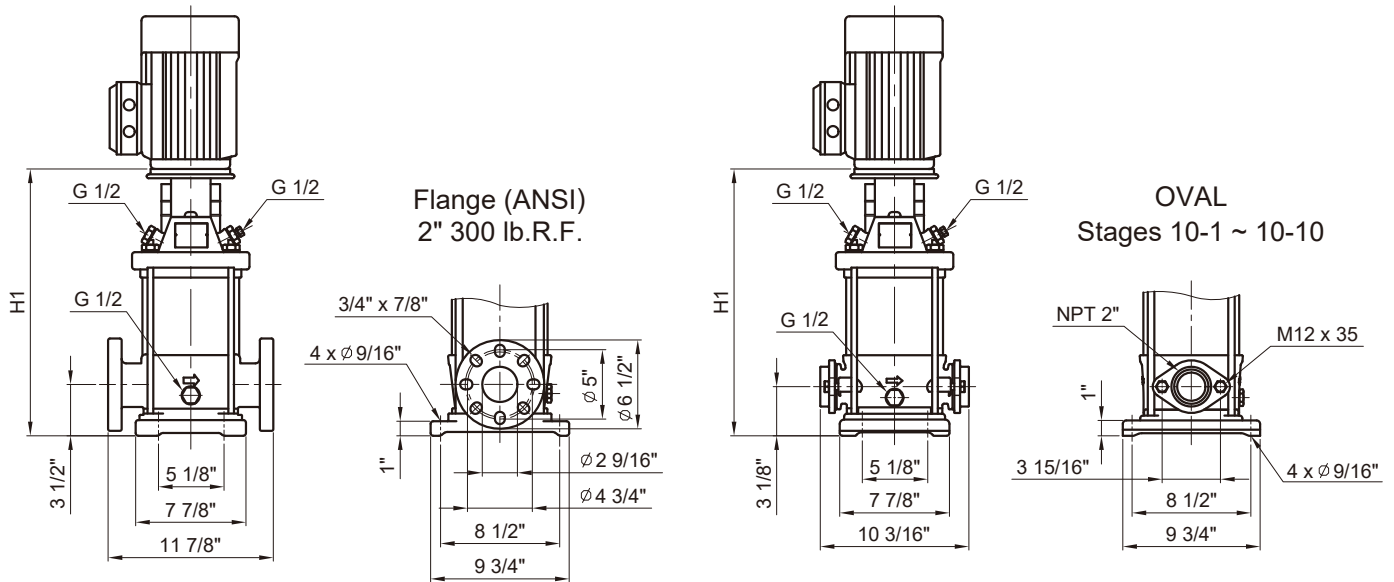

Pump type	Recommend Motor of HP		SBI					
	P 2		NEMA Frame TEFC motors	NEMA Frame ODP motors	Dimension[inch]		Weights[lbs]	
	[HP]	[Ph]			H1		ANSI flange	OVAL
					ANSI flange	OVAL		
SBI 10-1	3/4	1 / 3	56C	-	14.96	14.53	59.3	55.4
SBI 10-2	1 1/2	1 / 3	56C	-	14.96	14.53	59.7	55.8
SBI 10-3	3	1 / 3	182TC	-	17.15	16.71	84.0	80.1
SBI 10-4	3	1 / 3	182TC	-	18.35	17.91	86.2	82.3
SBI 10-5	5	1	213TC	-	20.12	19.68	93.3	89.4
		3	182TC	-	19.53	19.09	88.4	84.5
SBI 10-6	5	1	213TC	-	21.30	20.87	95.5	91.6
		3	182TC	-	20.71	20.28	90.6	86.7
SBI 10-7	5	1	213TC	-	22.44	22.00	97.8	93.9
		3	182TC	-	21.85	21.41	92.9	89.0
SBI 10-8	7 1/2	1 / 3	213TC	-	23.62	23.19	102.2	98.4
SBI 10-9	7 1/2	1 / 3	213TC	-	24.80	24.37	104.4	100.5
SBI 10-10	7 1/2	1 / 3	213TC	-	25.98	25.55	106.6	102.7
SBI 10-12	10	1 / 3	213TC	-	28.34	-	111.0	-
SBI 10-14	10	1 / 3	213TC	-	30.74	-	115.4	-
SBI 10-16	15	3	254TC	254TC	35.69	-	129.7	-
SBI 10-17	15	3	254TC	254TC	36.89	-	132.1	-

* For the 5HP single phase TEFC motor, we provide 213TC Frame

Contents

Vertical Multistage Centrifugal In-line Pumps



Dimension and weights-SBN 10

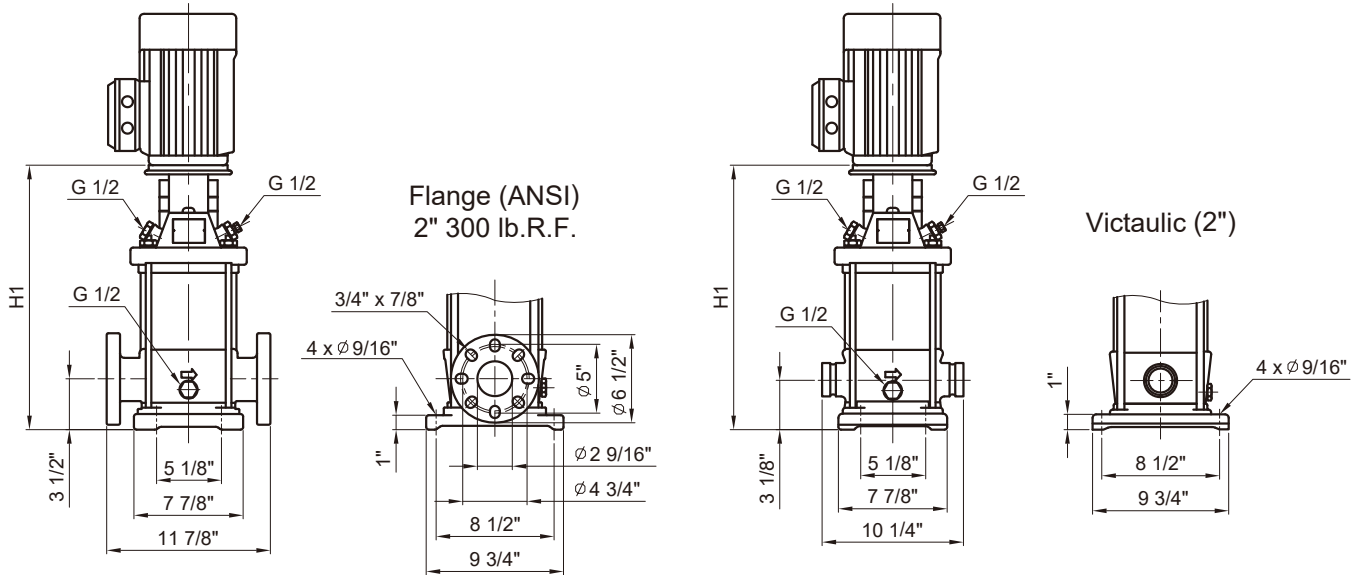

Pump type	Recommend Motor of HP		SBN					
	P 2		NEMA Frame TEFC motors	NEMA Frame ODP motors	Dimension[inch]		Weights[lbs]	
	[HP]	[Ph]			H1		ANSI flange	Victaulic
					ANSI flange	Victaulic		
SBN 10-1	3/4	1 / 3	56C	-	14.96	14.53	59.3	58.0
SBN 10-2	1 1/2	1 / 3	56C	-	14.96	14.53	59.7	58.4
SBN 10-3	3	1 / 3	182TC	-	17.15	16.71	84.0	82.6
SBN 10-4	3	1 / 3	182TC	-	18.35	17.91	86.2	84.9
SBN 10-5	5	1	213TC	-	20.12	19.68	93.3	91.9
		3	182TC	-	19.53	19.09	88.4	87.0
SBN 10-6	5	1	213TC	-	21.30	20.87	95.5	94.1
		3	182TC	-	20.71	20.28	90.6	89.2
SBN 10-7	5	1	213TC	-	22.44	22.00	97.8	96.4
		3	182TC	-	21.85	21.41	92.9	91.5
SBN 10-8	7 1/2	1 / 3	213TC	-	23.62	23.19	102.2	100.9
SBN 10-9	7 1/2	1 / 3	213TC	-	24.80	24.37	104.4	103.0
SBN 10-10	7 1/2	1 / 3	213TC	-	25.98	25.55	106.6	105.3
SBN 10-12	10	1 / 3	213TC	-	28.34	27.91	111.0	109.7
SBN 10-14	10	1 / 3	213TC	-	30.74	30.31	115.4	114.1
SBN 10-16	15	3	254TC	254TC	35.69	35.26	129.7	128.3
SBN 10-17	15	3	254TC	254TC	36.89	37.62	132.1	130.8

* For the 5HP single phase TEFC motor, we provide 213TC Frame

Contents

Vertical Multistage Centrifugal In-line Pumps



SB, SBI, SBN 15

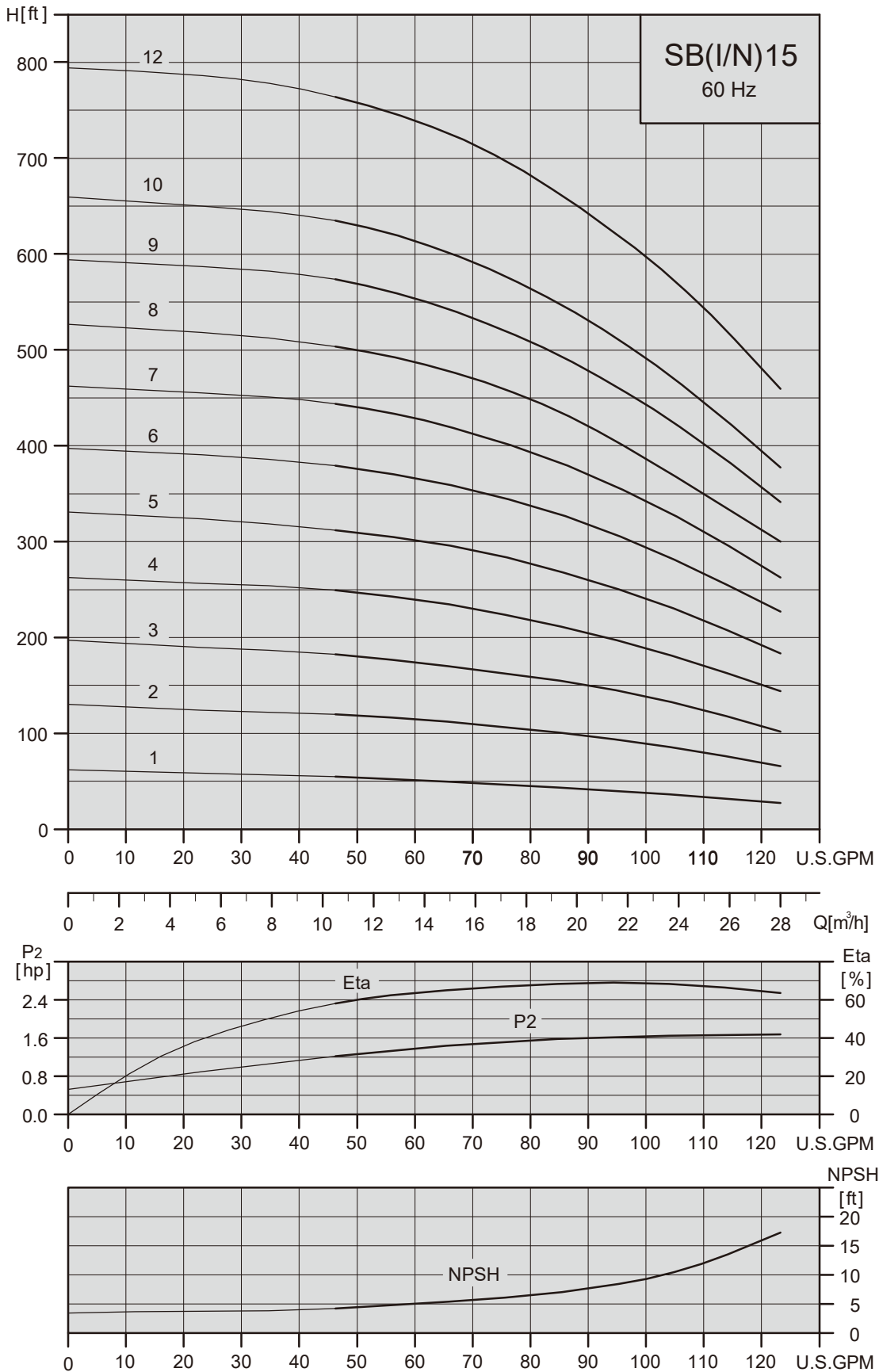

Contents

Vertical Multistage Centrifugal In-line Pumps



Dimension and weights-SB 15

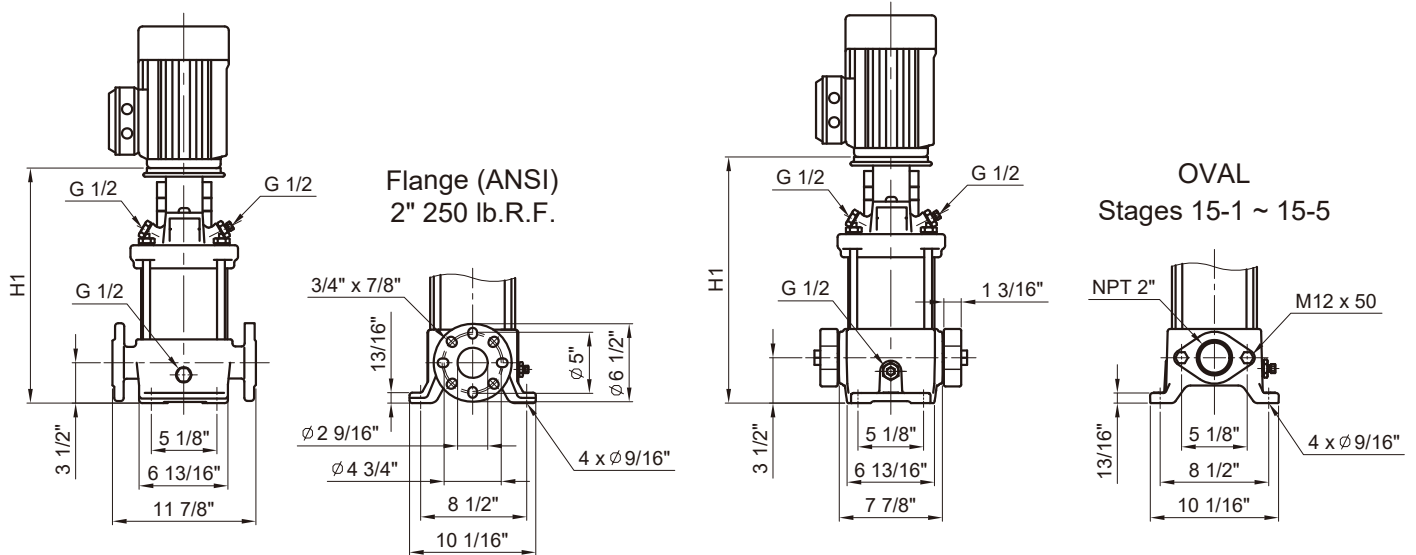

Pump type	Recommend Motor of HP		SB					
			NEMA Frame TEFC motors	NEMA Frame ODP motors	Dimension[inch]		Weights[lbs]	
	P2				H1		ANSI flange	OVAL
	[HP]	[Ph]			ANSI flange	OVAL		
SB 15-1	2	1 / 3	56C	-	16.24	16.24	77.4	65.5
SB 15-2	5	1	213TC	-	19.55	19.55	96.6	84.7
		3	182TC	-	18.37	18.37	91.7	79.8
SB 15-3	5	1	213TC	-	21.89	21.89	99.7	87.6
		3	182TC	-	18.96	18.96	94.8	82.7
SB 15-4	7 1/2	1 / 3	213TC	-	21.30	21.30	105.0	93.1
SB 15-5	10	1 / 3	213TC	-	23.07	23.07	108.1	96.2
SB 15-6	10	1 / 3	213TC	-	24.87	-	111.2	-
SB 15-7	15	3	254TC	254TC	29.24	-	123.5	-
SB 15-8	15	3	254TC	254TC	31.01	-	126.6	-
SB 15-9	15	3	254TC	254TC	32.78	-	129.7	-
SB 15-10	20	3	254TC	254TC	34.55	-	132.8	-
SB 15-12	25	3	284TSC	284TSC	37.40	-	140.4	-

* For the 5HP single phase TEFC motor, we provide 213TC Frame

Contents

Vertical Multistage Centrifugal In-line Pumps



Dimension and weights-SBI 15

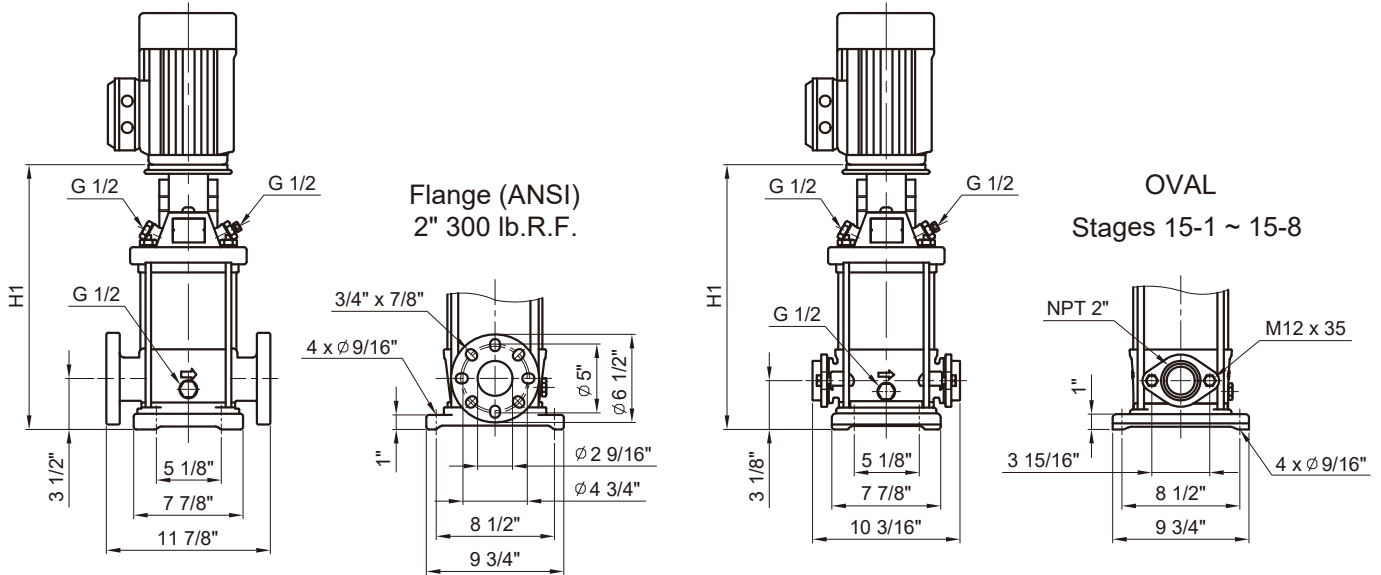

Pump type	Recommend Motor of HP		SBI					
	P2		NEMA Frame TEFC motors	NEMA Frame ODP motors	Dimension[inch]		Weights[lbs]	
	[HP]	[Ph]			H1		ANSI flange	OVAL
					ANSI flange	OVAL		
SBI 15-1	2	1 / 3	56C	-	16.10	15.71	60.9	57.0
SBI 15-2	5	1	213TC	-	17.72	17.32	88.5	84.6
		3	182TC	-	17.13	16.73	83.6	79.7
SBI 15-3	5	1	213TC	-	19.49	19.09	91.5	87.6
		3	182TC	-	18.90	18.50	86.6	82.7
SBI 15-4	7 1/2	1 / 3	213TC	-	21.22	20.82	96.8	92.9
SBI 15-5	10	1 / 3	213TC	-	22.99	22.59	99.8	95.9
SBI 15-6	10	1 / 3	213TC	-	24.80	24.40	103.0	99.1
SBI 15-7	15	3	254TC	254TC	29.16	28.76	115.9	112.0
SBI 15-8	15	3	254TC	254TC	30.93	30.54	118.9	115.0
SBI 15-9	15	3	254TC	254TC	32.70	-	122.0	-
SBI 15-10	20	3	254TC	254TC	34.47	-	125.3	-
SBI 15-12	25	3	284TSC	284TSC	37.26	-	125.4	-

* For the 5HP single phase TEFC motor, we provide 213TC Frame

Contents

Vertical Multistage Centrifugal In-line Pumps



Dimension and weights-SBN 15

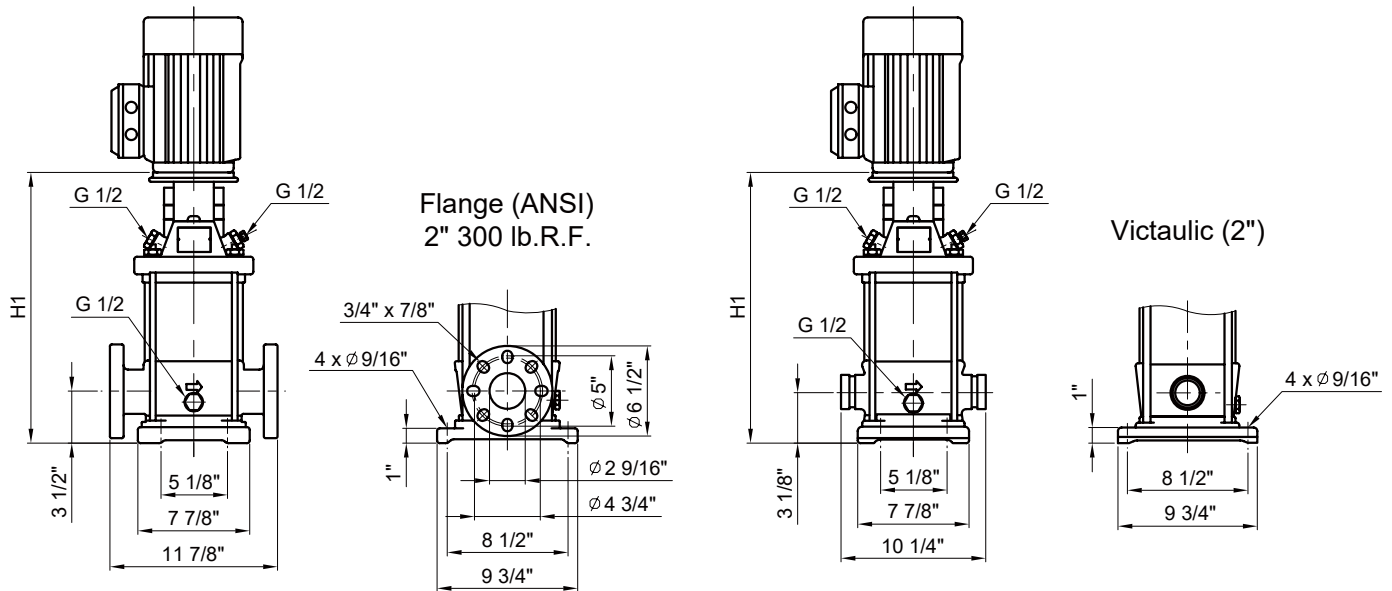

Pump type	Recommend Motor of HP		SBN					
	P2		NEMA Frame TEFC motors	NEMA Frame ODP motors	Dimension[inch]		Weights[lbs]	
	[HP]	[Ph]			H1		ANSI flange	Victaulic
					ANSI flange	Victaulic		
SBN 15-1	2	1 / 3	56C	-	16.10	15.71	60.9	59.5
SBN 15-2	5	1	213TC	-	17.72	17.32	88.5	87.1
		3	182TC	-	17.13	16.73	83.6	82.2
SBN 15-3	5	1	213TC	-	19.49	19.09	91.5	90.1
		3	182TC	-	18.90	18.50	86.6	85.2
SBN 15-4	7 1/2	1 / 3	213TC	-	21.22	20.82	96.8	95.4
SBN 15-5	10	1 / 3	213TC	-	22.99	22.59	99.8	98.5
SBN 15-6	10	1 / 3	213TC	-	24.80	24.40	103.0	101.7
SBN 15-7	15	3	254TC	254TC	29.16	28.76	115.9	114.6
SBN 15-8	15	3	254TC	254TC	30.93	30.54	118.9	117.6
SBN 15-9	15	3	254TC	254TC	32.70	32.31	122.0	120.7
SBN 15-10	20	3	254TC	254TC	34.47	34.08	125.3	123.9
SBN 15-12	25	3	284TSC	284TSC	37.26	36.87	125.4	124.1

* For the 5HP single phase TEFC motor, we provide 213TC Frame

Contents

Vertical Multistage Centrifugal In-line Pumps



SB, SBI, SBN 20

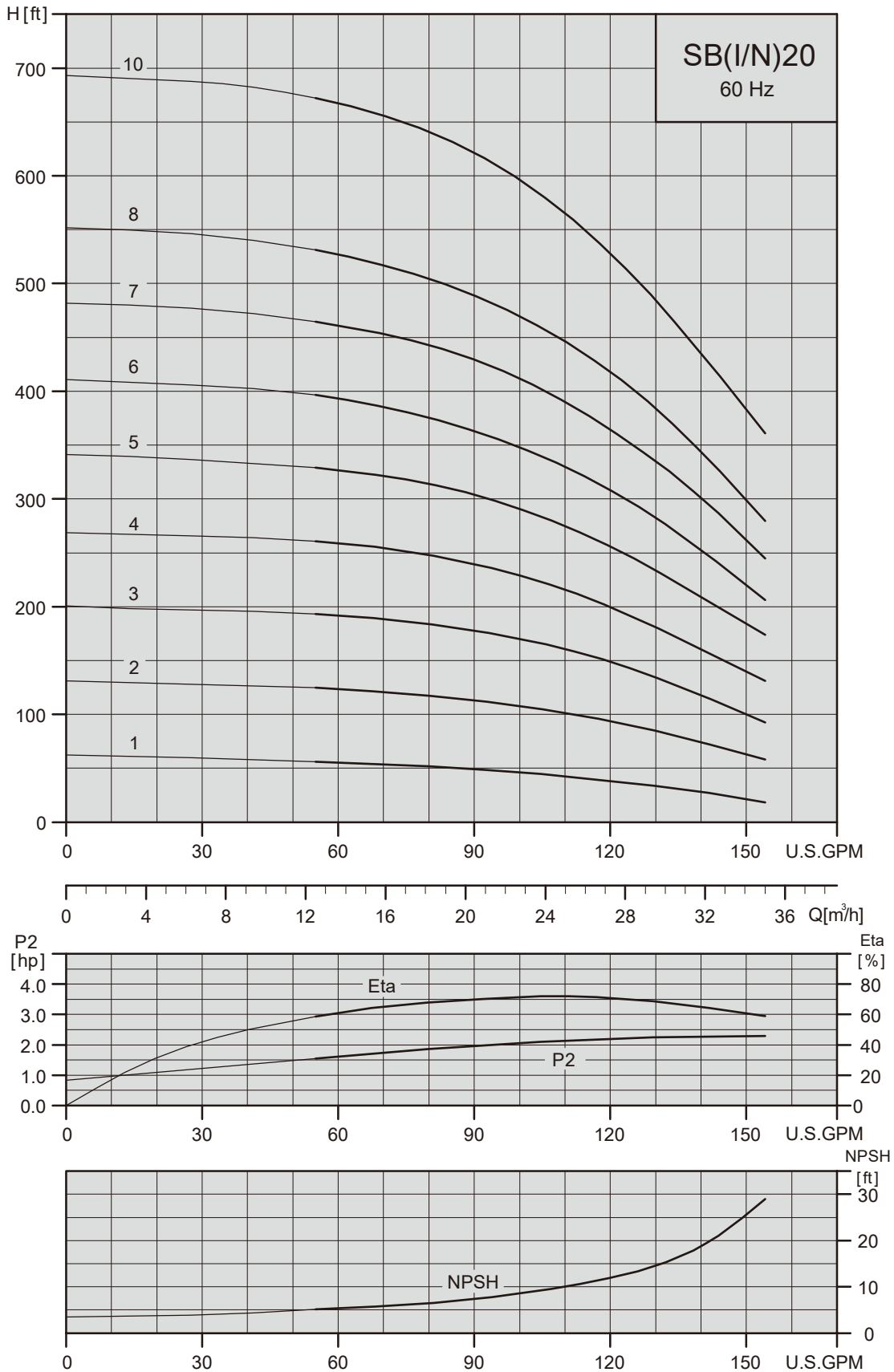

Contents

Vertical Multistage Centrifugal In-line Pumps



Dimension and weights-SB 20

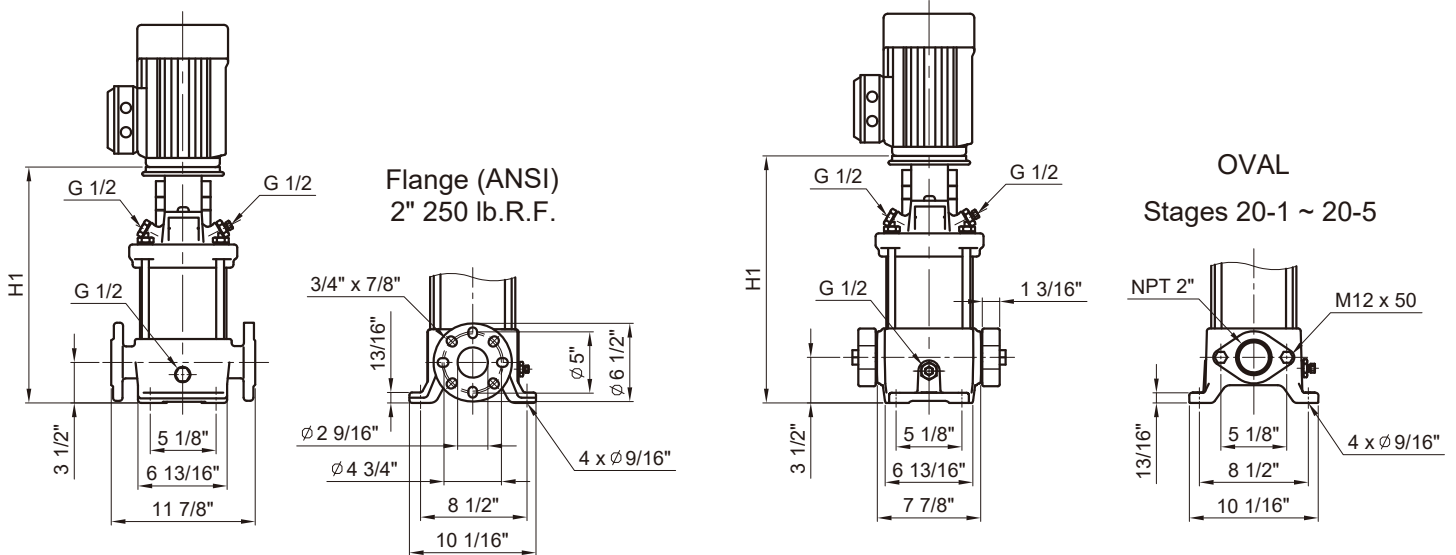

Pump type	Recommend Motor of HP		SB					
	P2		NEMA Frame TEFC motors	NEMA Frame ODP motors	Dimension[inch]		Weights[lbs]	
	[HP]	[Ph]			H1		ANSI flange	OVAL
SB 20-1	3	1 / 3	182TC	-	17.19	17.19	91.1	79.3
SB 20-2	5	1	213TC	-	17.78	17.78	96.6	84.7
		3	182TC	-	17.19	17.19	91.7	79.8
SB 20-3	7 1/2	1 / 3	213TC	-	19.52	19.52	101.9	90.0
SB 20-4	10	1 / 3	213TC	-	21.30	21.30	105.0	93.1
SB 20-5	15	3	254TC	254TC	25.69	25.69	117.3	105.4
SB 20-6	15	3	254TC	254TC	27.46	-	120.4	-
SB 20-7	20	3	254TC	254TC	29.24	-	123.5	-
SB 20-8	20	3	254TC	254TC	31.01	-	126.6	-
SB 20-10	25	3	284TSC	284TSC	33.86	-	134.0	-

* For the 5HP single phase TEFC motor, we provide 213TC Frame

Contents

Vertical Multistage Centrifugal In-line Pumps



Dimension and weights-SBI 20

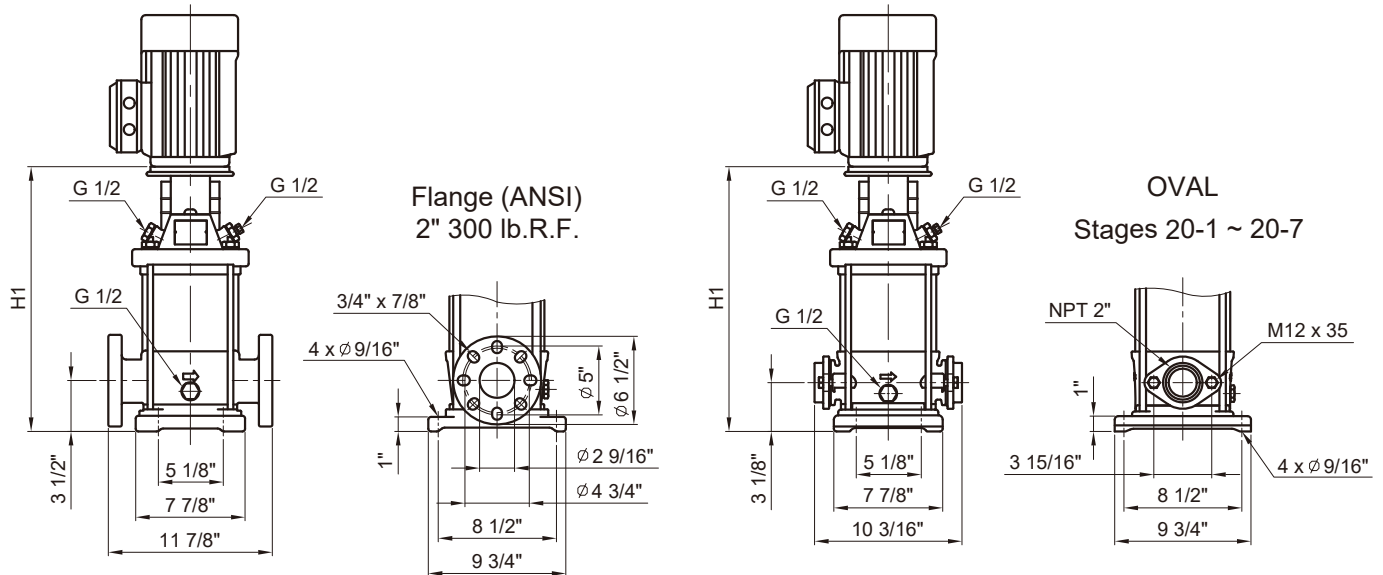

Pump type	Recommend Motor of HP		SBI					
			NEMA Frame TEFC motors	NEMA Frame ODP motors	Dimension[inch]		Weights[lbs]	
	P2				H1		ANSI flange	OVAL
	[HP]	[Ph]			ANSI flange	OVAL		
SBI 20-1	3	1 / 3	182TC	-	17.19	16.79	83.0	79.1
SBI 20-2	5	1	213TC	-	17.79	17.40	88.5	84.6
		3	182TC	-	17.20	16.81	83.6	79.7
SBI 20-3	7 1/2	1 / 3	213TC	-	19.52	19.13	93.7	89.8
SBI 20-4	10	1 / 3	213TC	-	21.30	20.90	96.8	92.9
SBI 20-5	15	3	254TC	254TC	25.69	25.30	109.6	105.8
SBI 20-6	15	3	254TC	254TC	27.46	27.07	112.8	108.9
SBI 20-7	20	3	254TC	254TC	29.24	28.84	115.9	112.0
SBI 20-8	20	3	254TC	254TC	31.01	-	118.9	-
SBI 20-10	25	3	284TSC	284TSC	33.80	-	119.4	-

* For the 5HP single phase TEFC motor, we provide 213TC Frame

Contents

Vertical Multistage Centrifugal In-line Pumps



Dimension and weights-SBN 20

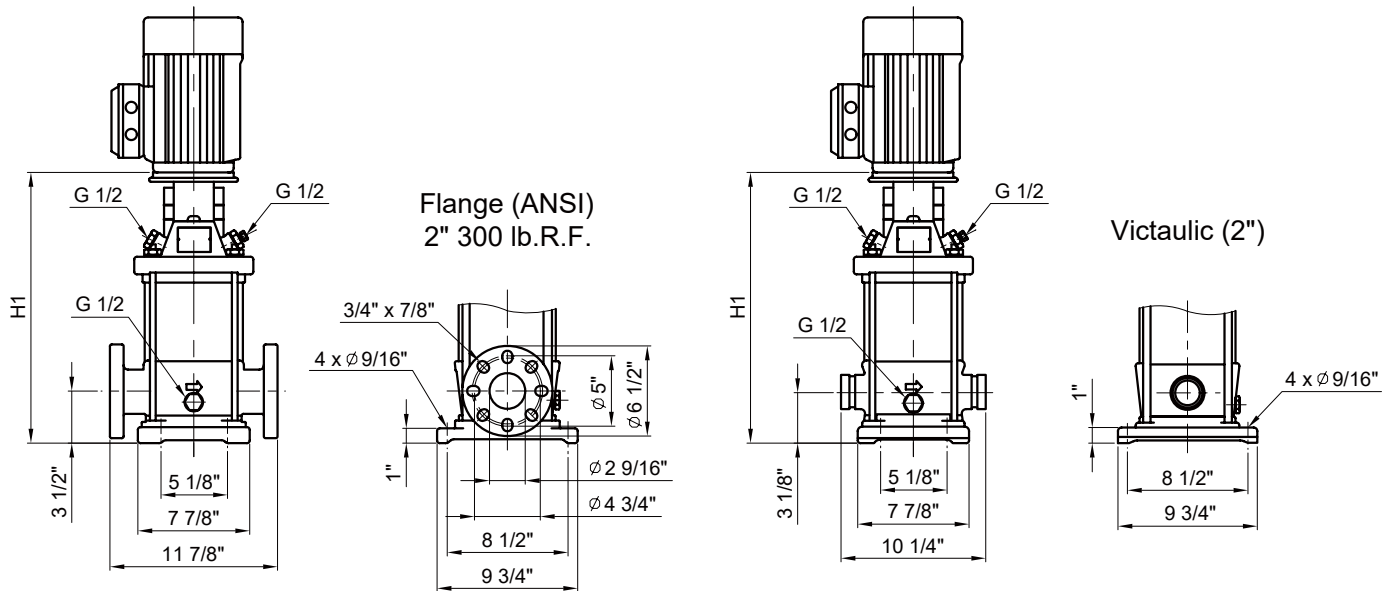

Pump type	Recommend motor of HP			SBN					
				NEMA Frame TEFC motors	NEMA Frame ODP motors	Dimension[inch]		Weights[lbs]	
	P ₂		H1			ANSI flange	Victaulic		
	[HP]	[kW]	[PH]					ANSI flange	Victaulic
SBN 20-1	3	2.2	1 / 3	182TC	-	17.19	16.79	83	86
SBN 20-2	5	3.7	1 / 3	182TC	-	17.2	16.81	84	83
SBN 20-3	7 1/2	5.5	1 / 3	213TC	-	19.52	19.13	94	93
SBN 20-4	10	7.5	1 / 3	213TC	-	21.3	20.9	97	96
SBN 20-5	15	11	3	254TC	254TC	25.69	25.3	110	109
SBN 20-6	15	11	3	254TC	254TC	27.46	27.07	113	112
SBN 20-7	20	15	3	254TC	254TC	29.24	28.84	116	115
SBN 20-8	20	15	3	254TC	254TC	31.01	30.61	119	118
SBN 20-10	25	18.5	3	284TSC	284TSC	33.8	33.41	120	119

* For the 5HP single phase TEFC motor, we provide 213TC Frame

Contents

Vertical Multistage Centrifugal In-line Pumps



SB, SBI, SBN 32

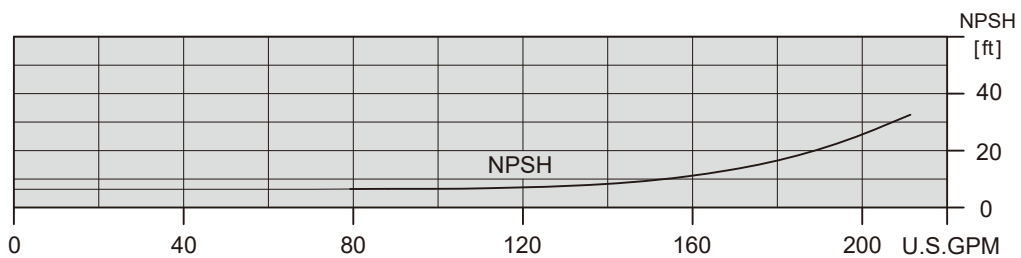
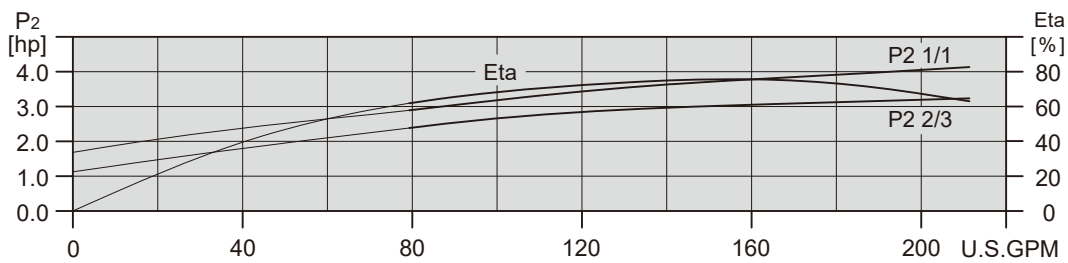
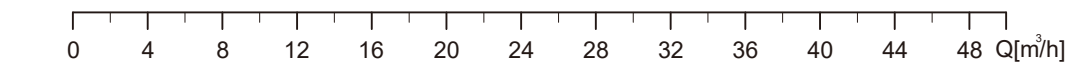
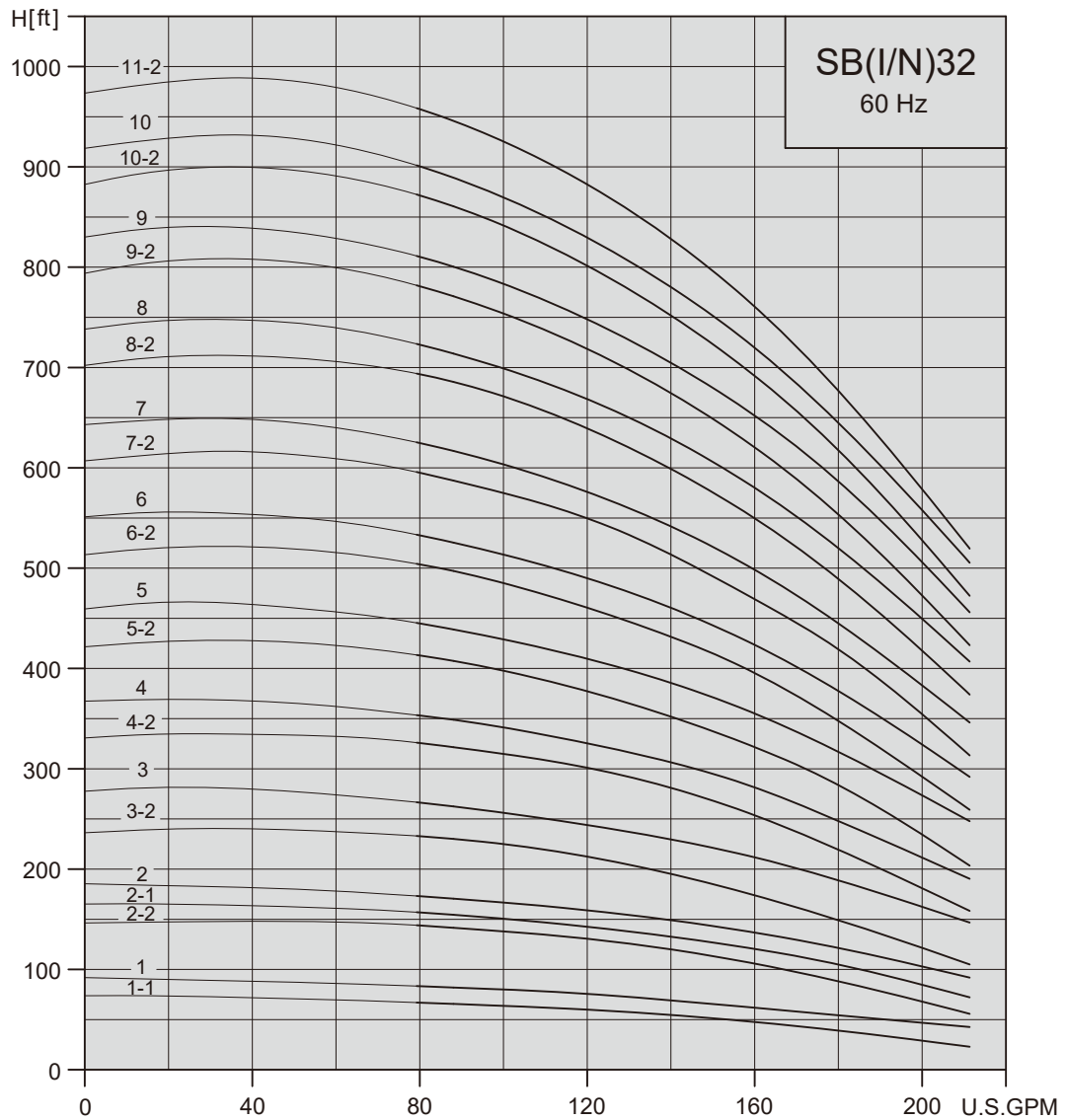

Contents

Vertical Multistage Centrifugal In-line Pumps



Dimension and weights-SB 32

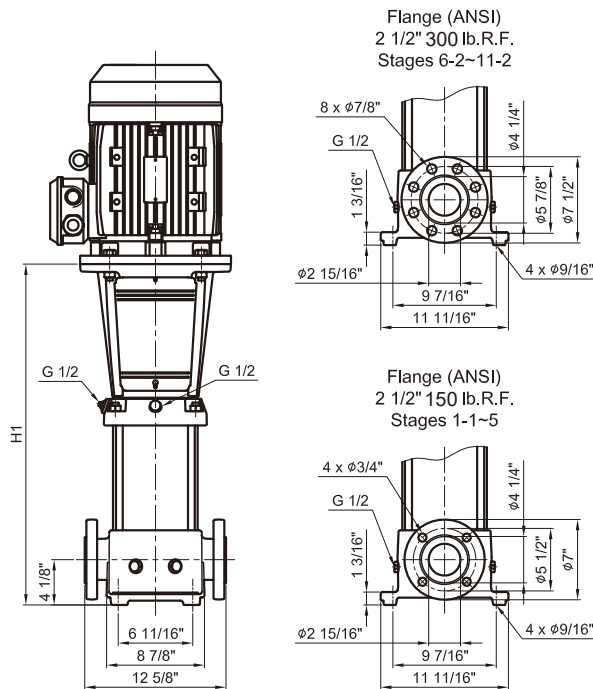

Pump type	Recommend Motor of HP		SB			
	P2		NEMA Frame TEFC motors	NEMA Frame ODP motors	Dimension [inch]	Weights[lbs]
	[HP]	[Ph]			ANSI flange	ANSI flange
				H1		
SB 32-1-1	3	1 / 3	182TC	-	20.02	120.7
SB 32-1	5	1 / 3	213TC / 182TC	-	20.02	120.7
SB 32-2-2	7 1/2	1 / 3	213TC	-	22.78	127.2
SB 32-2-1	7 1/2	1 / 3	213TC	-	22.78	127.4
SB 32-2	7 1/2	1 / 3	213TC	-	22.78	127.4
SB 32-3-2	10	1 / 3	213TC	-	25.53	133.8
SB 32-3	15	3	254TC	254TC	29.67	155.2
SB 32-4-2	15	3	254TC	254TC	32.42	161.8
SB 32-4	15	3	254TC	254TC	32.42	161.8
SB 32-5-2	20	3	254TC	254TC	35.18	168.4
SB 32-5	20	3	254TC	254TC	35.18	168.4
SB 32-6-2	25	3	284TSC	284TSC	37.93	177.2
SB 32-6	25	3	284TSC	284TSC	37.93	177.2
SB 32-7-2	30	3	286TSC	284TSC	40.69	183.9
SB 32-7	30	3	286TSC	284TSC	40.69	183.9
SB 32-8-2	30	3	286TSC	284TSC	43.44	190.8
SB 32-8	40	3	286TSC	286TSC	43.44	190.8
SB 32-9-2	40	3	286TSC	286TSC	46.20	196.8
SB 32-9	40	3	286TSC	286TSC	46.20	196.8
SB 32-10-2	40	3	286TSC	286TSC	48.96	202.5
SB 32-10	40	3	286TSC	286TSC	48.96	202.5
SB 32-11-2	40	3	286TSC	286TSC	51.71	208.4

* For the 5HP single phase TEFC motor, we provide 213TC Frame

Contents

Vertical Multistage Centrifugal In-line Pumps



Dimension and weights-SBI(N) 32

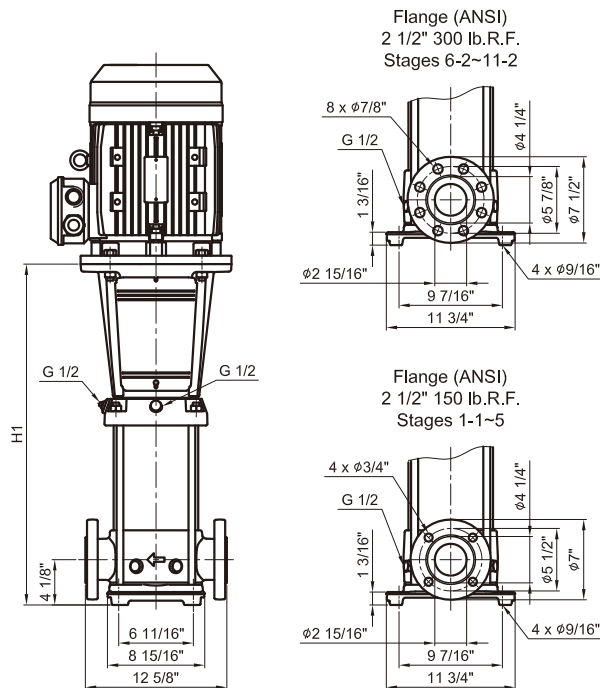

Pump type	Recommend Motor of HP		SBI,SBN			
	P2		NEMA Frame TEFC motors	NEMA Frame ODP motors	Dimension [inch]	Weights[lbs]
	[HP]	[Ph]			ANSI flange	ANSI flange
				H1		
SBI, SBN 32-1-1	3	1 / 3	182TC	-	20.02	110.0
SBI, SBN 32-1	5	1 / 3	213TC / 182TC	-	20.02	110.0
SBI, SBN 32-2-2	7 1/2	1 / 3	213TC	-	22.78	116.6
SBI, SBN 32-2-1	7 1/2	1 / 3	213TC	-	22.78	116.6
SBI, SBN 32-2	7 1/2	1 / 3	213TC	-	22.78	116.6
SBI, SBN 32-3-2	10	1 / 3	213TC	-	25.53	123.3
SBI, SBN 32-3	15	3	254TC	254TC	29.67	144.4
SBI, SBN 32-4-2	15	3	254TC	254TC	32.42	151.0
SBI, SBN 32-4	15	3	254TC	254TC	32.42	151.0
SBI, SBN 32-5-2	20	3	254TC	254TC	35.18	157.6
SBI, SBN 32-5	20	3	254TC	254TC	35.18	157.8
SBI, SBN 32-6-2	25	3	284TSC	284TSC	37.93	166.4
SBI, SBN 32-6	25	3	284TSC	284TSC	37.93	166.6
SBI, SBN 32-7-2	30	3	286TSC	284TSC	40.69	173.1
SBI, SBN 32-7	30	3	286TSC	284TSC	40.69	173.3
SBI, SBN 32-8-2	30	3	286TSC	284TSC	43.44	180.3
SBI, SBN 32-8	40	3	286TSC	286TSC	43.44	180.3
SBI, SBN 32-9-2	40	3	286TSC	286TSC	46.20	186.0
SBI, SBN 32-9	40	3	286TSC	286TSC	46.20	186.2
SBI, SBN 32-10-2	40	3	286TSC	286TSC	48.96	191.7
SBI, SBN 32-10	40	3	286TSC	286TSC	48.96	191.7
SBI, SBN 32-11-2	40	3	286TSC	286TSC	51.71	197.7

* For the 5HP single phase TEFC motor, we provide 213TC Frame

Contents

Vertical Multistage Centrifugal In-line Pumps



SB, SBI, SBN 45

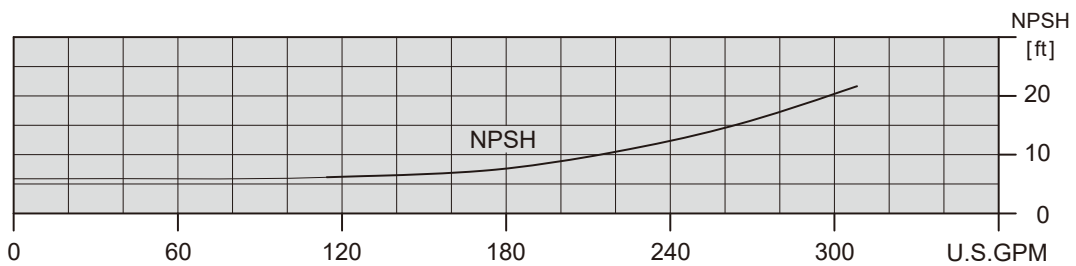
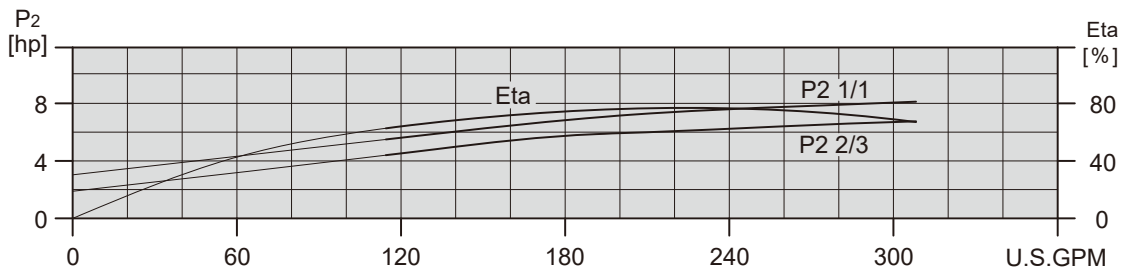
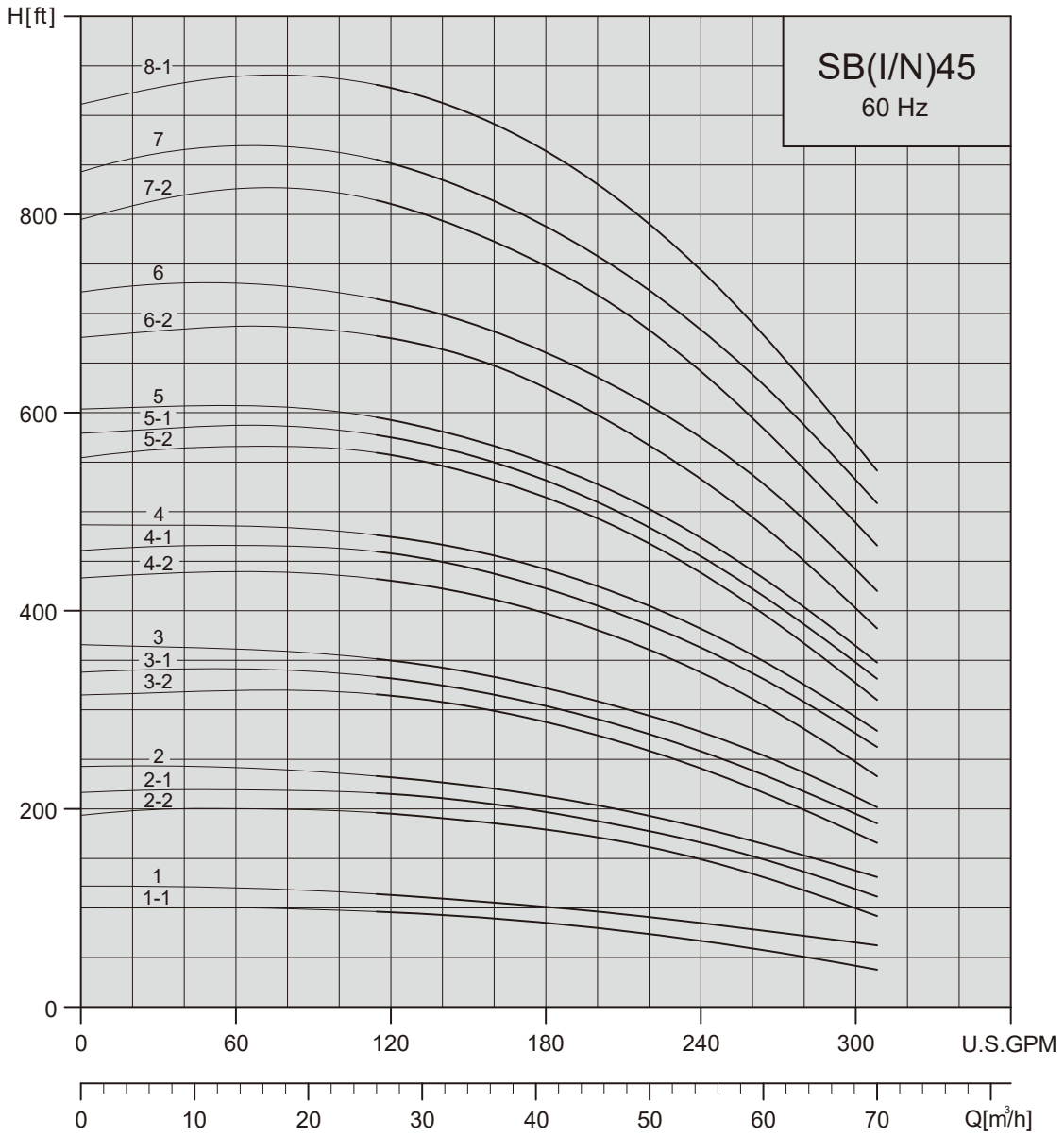

Contents

Vertical Multistage Centrifugal In-line Pumps



Dimension and weights-SB 45

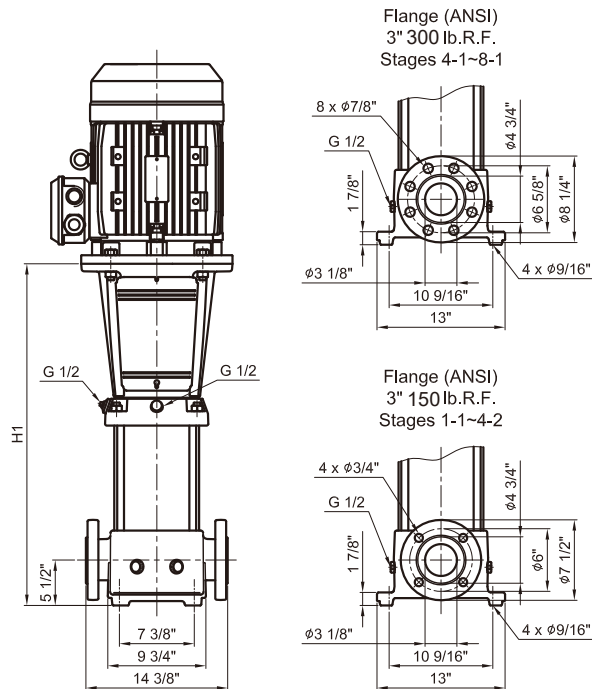

Pump type	Recommend Motor of HP		SB			
	P 2		NEMA Frame TEFC motors	NEMA Frame ODP motors	Dimension [inch]	Weights[lbs]
	[HP]	[Ph]			ANSI flange	ANSI flange
				H1		
SB 45-1-1	7 1/2	1 / 3	213TC	-	22.26	143.4
SB 45-1	7 1/2	1 / 3	213TC	-	22.26	143.4
SB 45-2-2	15	3	254TC	254TC	29.55	172.6
SB 45-2-1	15	3	254TC	254TC	29.55	172.6
SB 45-2	15	3	254TC	254TC	29.55	172.6
SB 45-3-2	20	3	254TC	254TC	32.70	180.7
SB 45-3-1	25	3	284TSC	284TSC	32.70	182.9
SB 45-3	25	3	284TSC	284TSC	32.70	182.9
SB 45-4-2	30	3	286TSC	284TSC	35.85	190.9
SB 45-4-1	30	3	286TSC	284TSC	35.85	191.0
SB 45-4	30	3	286TSC	284TSC	35.85	191.0
SB 45-5-2	40	3	286TSC	286TSC	39.00	199.0
SB 45-5-1	40	3	286TSC	286TSC	39.00	199.0
SB 45-5	40	3	286TSC	286TSC	39.00	199.1
SB 45-6-2	50	3	326TSC	324TSC	42.15	224.5
SB 45-6	50	3	326TSC	324TSC	42.15	224.6
SB 45-7-2	50	3	326TSC	324TSC	45.30	232.6
SB 45-7	60	3	364TSC	324TSC	45.30	232.7
SB 45-8-1	60	3	364TSC	324TSC	48.44	239.8

Contents

Vertical Multistage Centrifugal In-line Pumps

Dimension and weights-SBI(N) 45

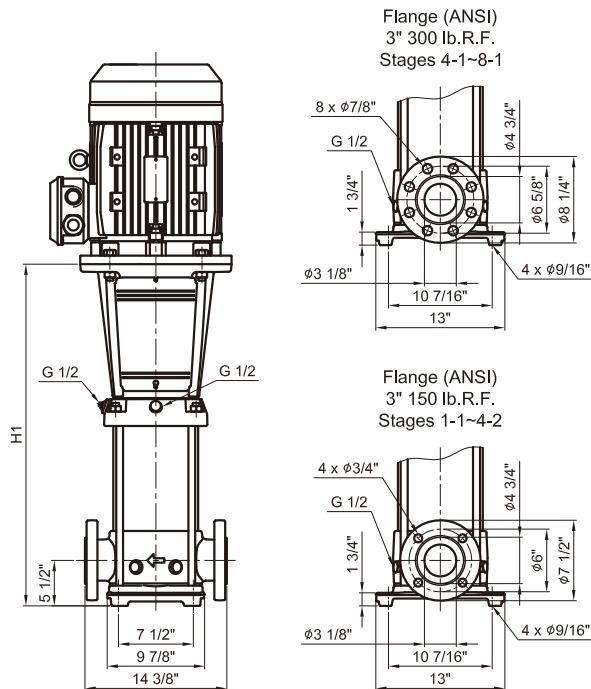

Pump type	Recommend Motor of HP		SBI, SBN			
	P 2		NEMA Frame TEFC motors	NEMA Frame ODP motors	Dimension [inch]	Weights[lbs]
	[HP]	[Ph]			ANSI flange	ANSI flange
					HI	
SBI, SBN 45-1-1	7 1/2	1 / 3	213TC	-	22.20	124.6
SBI, SBN 45-1	7 1/2	1 / 3	213TC	-	22.20	124.6
SBI, SBN 45-2-2	15	3	254TC	254TC	29.49	153.8
SBI, SBN 45-2-1	15	3	254TC	254TC	29.49	153.8
SBI, SBN 45-2	15	3	254TC	254TC	29.49	153.8
SBI, SBN 45-3-2	20	3	254TC	254TC	32.64	161.9
SBI, SBN 45-3-1	25	3	284TSC	284TSC	32.64	164.1
SBI, SBN 45-3	25	3	284TSC	284TSC	32.64	164.1
SBI, SBN 45-4-2	30	3	286TSC	284TSC	35.79	172.1
SBI, SBN 45-4-1	30	3	286TSC	284TSC	35.79	172.1
SBI, SBN 45-4	30	3	286TSC	284TSC	35.79	172.2
SBI, SBN 45-5-2	40	3	286TSC	286TSC	38.94	180.2
SBI, SBN 45-5-1	40	3	286TSC	286TSC	38.94	180.2
SBI, SBN 45-5	40	3	286TSC	286TSC	38.94	180.3
SBI, SBN 45-6-2	50	3	326TSC	324TSC	42.09	205.7
SBI, SBN 45-6	50	3	326TSC	324TSC	42.09	205.8
SBI, SBN 45-7-2	50	3	326TSC	324TSC	45.24	213.8
SBI, SBN 45-7	60	3	364TSC	324TSC	45.24	213.9
SBI, SBN 45-8-1	60	3	364TSC	324TSC	48.39	221.0

Contents

Vertical Multistage Centrifugal In-line Pumps



SB, SBI, SBN 64

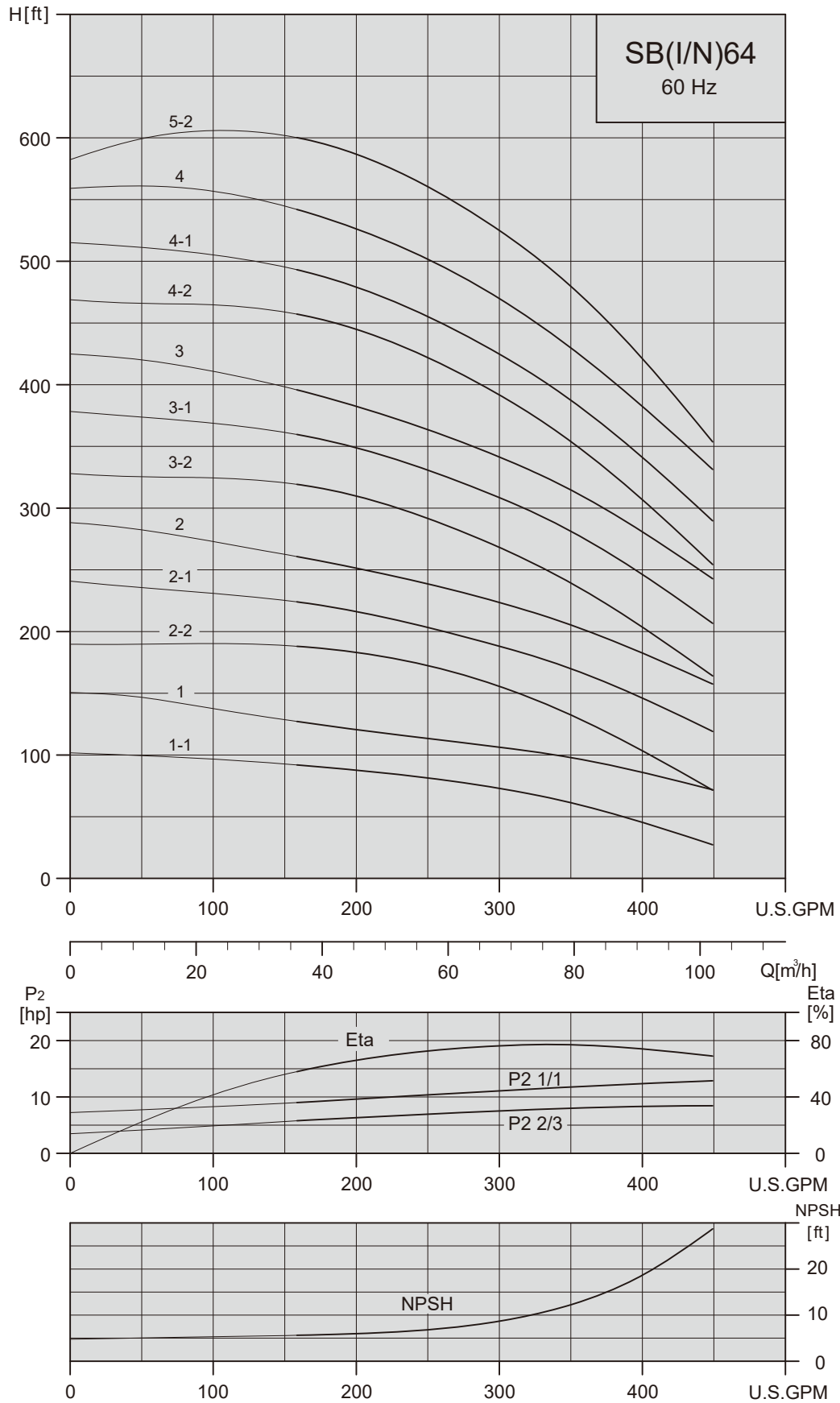

Contents

Vertical Multistage Centrifugal In-line Pumps



Dimension and weights-SB 64

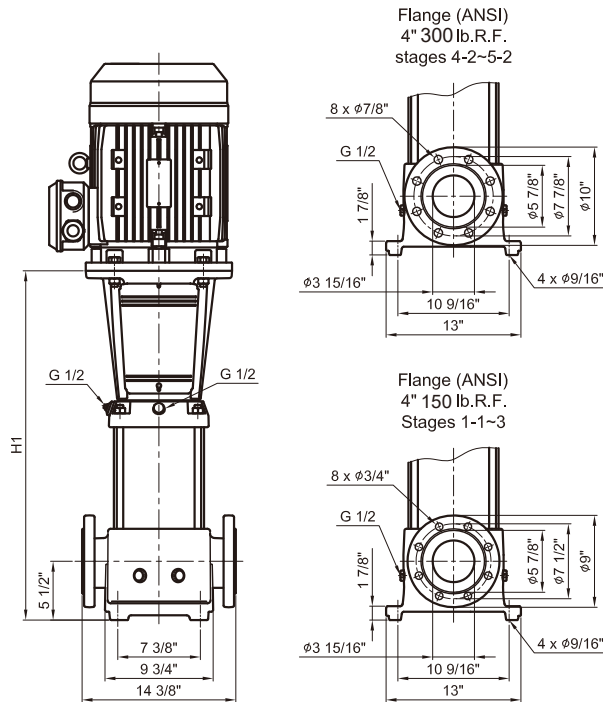

Pump type	Recommend Motor of HP		SB			
	P 2		NEMA Frame TEFC motors	NEMA Frame ODP motors	Dimension [inch]	Weights[lbs]
	[HP]	[Ph]			ANSI flange	ANSI flange
				H1		
SB 64-1-1	7 1/2	1 / 3	213TC	-	22.36	130.1
SB 64-1	15	3	254TC	254TC	26.50	151.3
SB 64-2-2	15	3	254TC	254TC	29.74	159.9
SB 64-2-1	20	3	254TC	254TC	29.74	159.9
SB 64-2	25	3	284TSC	284TSC	29.74	162.1
SB 64-3-2	30	3	286TSC	284TSC	32.99	171.9
SB 64-3-1	40	3	286TSC	286TSC	32.99	171.9
SB 64-3	40	3	286TSC	286TSC	32.99	171.9
SB 64-4-2	40	3	286TSC	286TSC	36.24	180.5
SB 64-4-1	50	3	326TSC	324TSC	36.24	198.0
SB 64-4	50	3	326TSC	324TSC	36.24	198.2
SB 64-5-2	60	3	364TSC	324TSC	39.49	206.6

Contents

Vertical Multistage Centrifugal In-line Pumps



Dimension and weights-SBI(N) 64

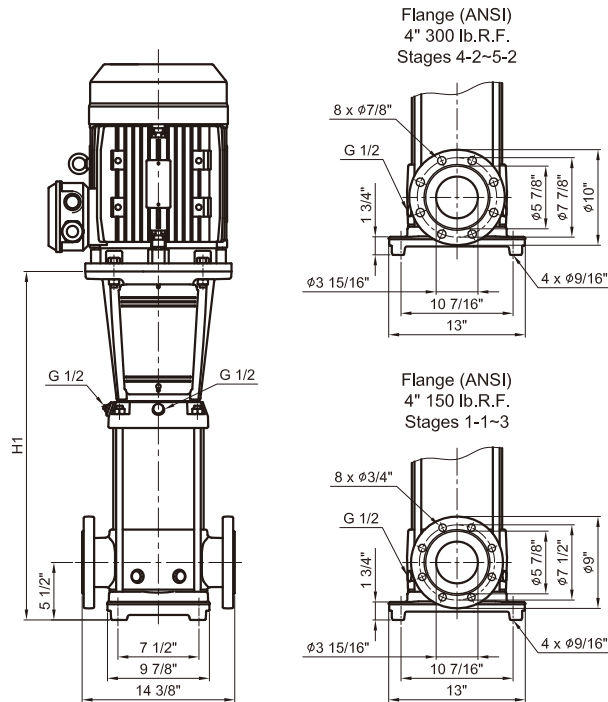

Pump type	Recommend Motor of HP		SBI, SBN			
	P 2		NEMA Frame TEFC motors	NEMA Frame ODP motors	Dimension [inch]	Weights[lbs]
	[HP]	[Ph]			ANSI flange H1	ANSI flange
SBI, SBN 64-1-1	7 1/2	1 / 3	213TC	-	22.36	115.1
SBI, SBN 64-1	15	3	254TC	254TC	26.50	136.2
SBI, SBN 64-2-2	15	3	254TC	254TC	29.74	144.9
SBI, SBN 64-2-1	20	3	254TC	254TC	29.74	144.9
SBI, SBN 64-2	25	3	284TSC	284TSC	29.74	147.1
SBI, SBN 64-3-2	30	3	286TSC	284TSC	32.99	155.9
SBI, SBN 64-3-1	40	3	286TSC	286TSC	32.99	155.9
SBI, SBN 64-3	40	3	286TSC	286TSC	32.99	155.9
SBI, SBN 64-4-2	40	3	286TSC	286TSC	36.24	164.4
SBI, SBN 64-4-1	50	3	326TSC	324TSC	36.24	181.9
SBI, SBN 64-4	50	3	326TSC	324TSC	36.24	181.9
SBI, SBN 64-5-2	60	3	364TSC	324TSC	39.49	190.4

Contents

Vertical Multistage Centrifugal In-line Pumps



SB, SBI, SBN 90

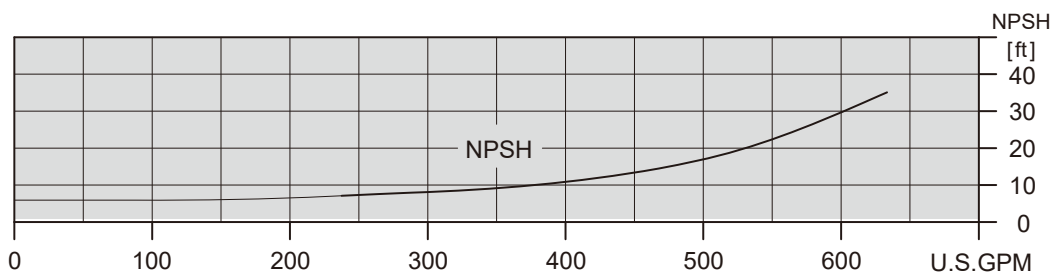
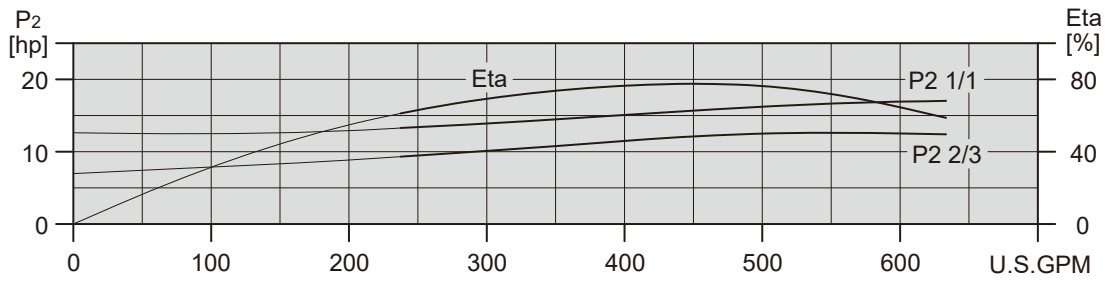
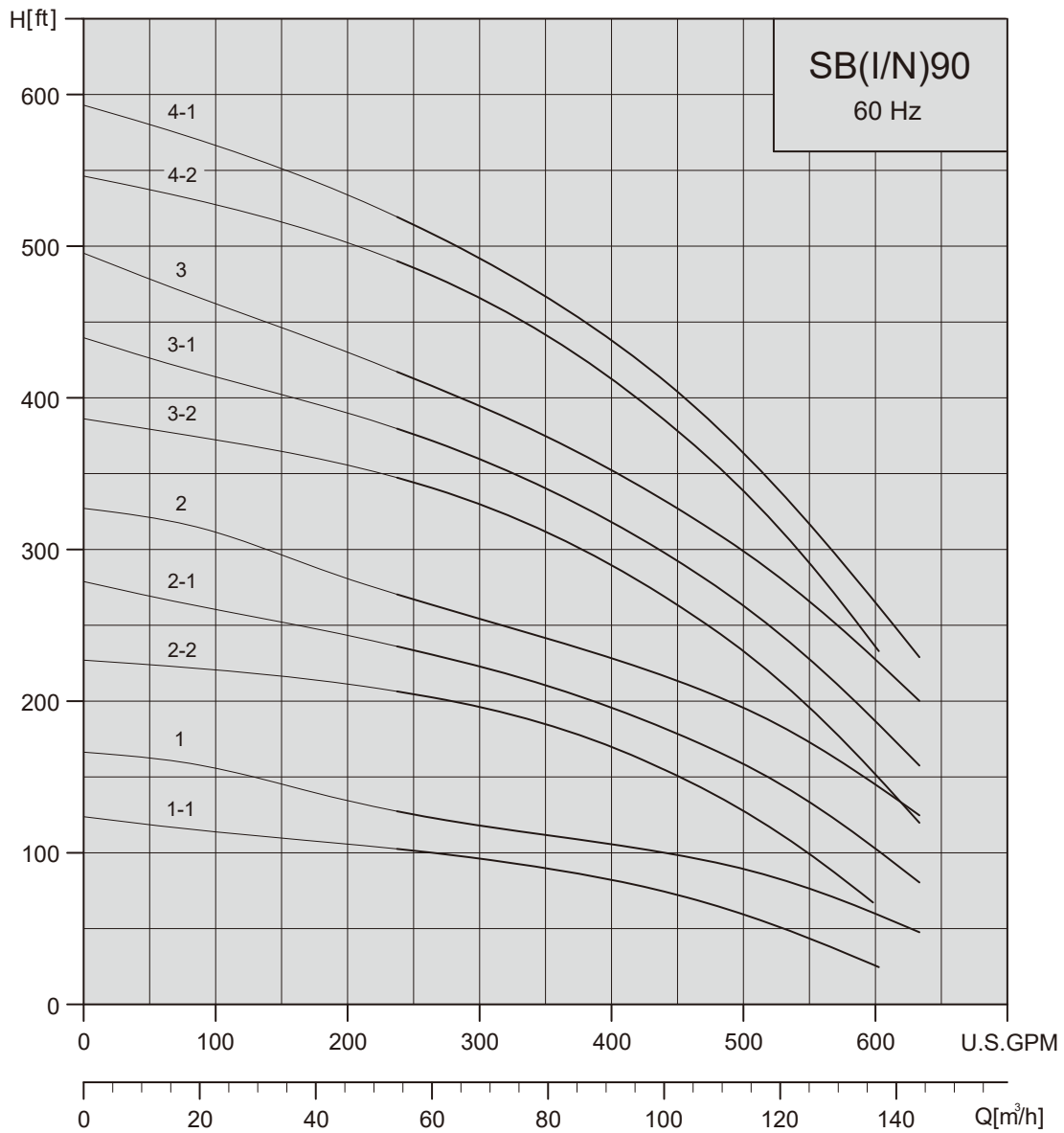

Contents

Vertical Multistage Centrifugal In-line Pumps



Dimension and weights-SB 90

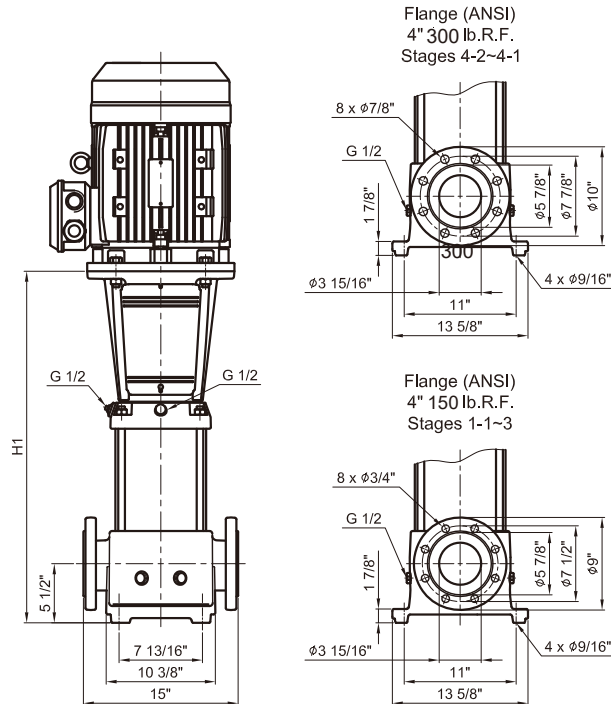

Pump type	Recommend Motor of HP		SB			
	P 2		NEMA Frame TEFC motors	NEMA Frame ODP motors	Dimension [inch]	Weights[lbs]
	[HP]	[Ph]			ANSI flange	ANSI flange
					H1	
SB 90-1-1	15	3	254TC	254TC	26.60	180.8
SB 90-1	15	3	254TC	254TC	26.60	180.9
SB 90-2-2	25	3	284TSC	284TSC	30.19	194.4
SB 90-2-1	30	3	286TSC	284TSC	30.19	194.4
SB 90-2	40	3	286TSC	286TSC	30.19	194.5
SB 90-3-2	40	3	286TSC	286TSC	33.77	205.7
SB 90-3-1	50	3	326TSC	324TSC	33.77	223.2
SB 90-3	50	3	326TSC	324TSC	33.77	223.2
SB 90-4-2	60	3	364TSC	324TSC	37.21	238.5
SB 90-4-1	60	3	364TSC	324TSC	37.21	238.9

Contents

Vertical Multistage Centrifugal In-line Pumps



Dimension and weights-SBI(N) 90

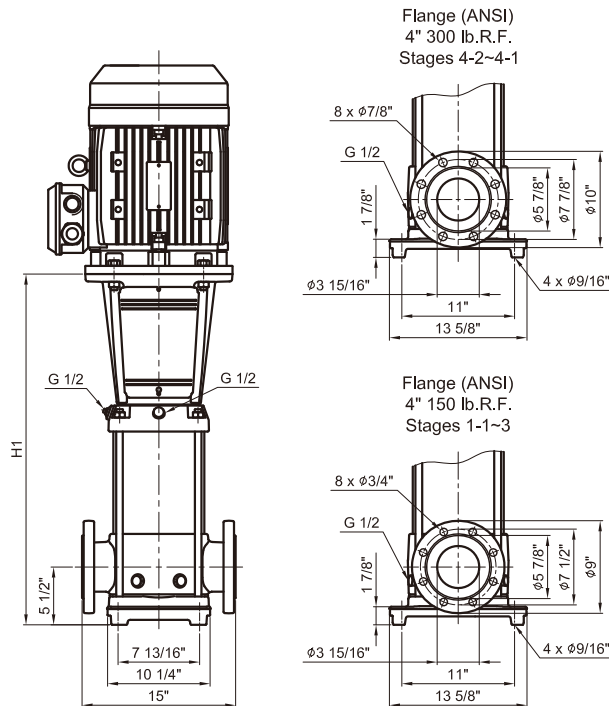

Pump type	Recommend Motor of HP		SBI,SBN			
			NEMA Frame TEFC motors	NEMA Frame ODP motors	Dimension [inch]	Weights[lbs]
	P2				ANSI flange	ANSI flange
	[HP]	[Ph]				
SBI, SBN 90-1-1	15	3	254TC	254TC	26.75	159.3
SBI, SBN 90-1	15	3	254TC	254TC	26.75	159.4
SBI, SBN 90-2-2	25	3	284TSC	284TSC	30.34	172.6
SBI, SBN 90-2-1	30	3	286TSC	284TSC	30.34	172.6
SBI, SBN 90-2	40	3	286TSC	286TSC	30.34	172.7
SBI, SBN 90-3-2	40	3	286TSC	286TSC	33.93	183.8
SBI, SBN 90-3-1	50	3	326TSC	324TSC	33.93	201.3
SBI, SBN 90-3	50	3	326TSC	324TSC	33.93	201.3
SBI, SBN 90-4-2	60	3	364TSC	324TSC	37.36	216.2
SBI, SBN 90-4-1	60	3	364TSC	324TSC	37.36	216.6

Contents

Vertical Multistage Centrifugal In-line Pumps



SB, SBI, SBN 120

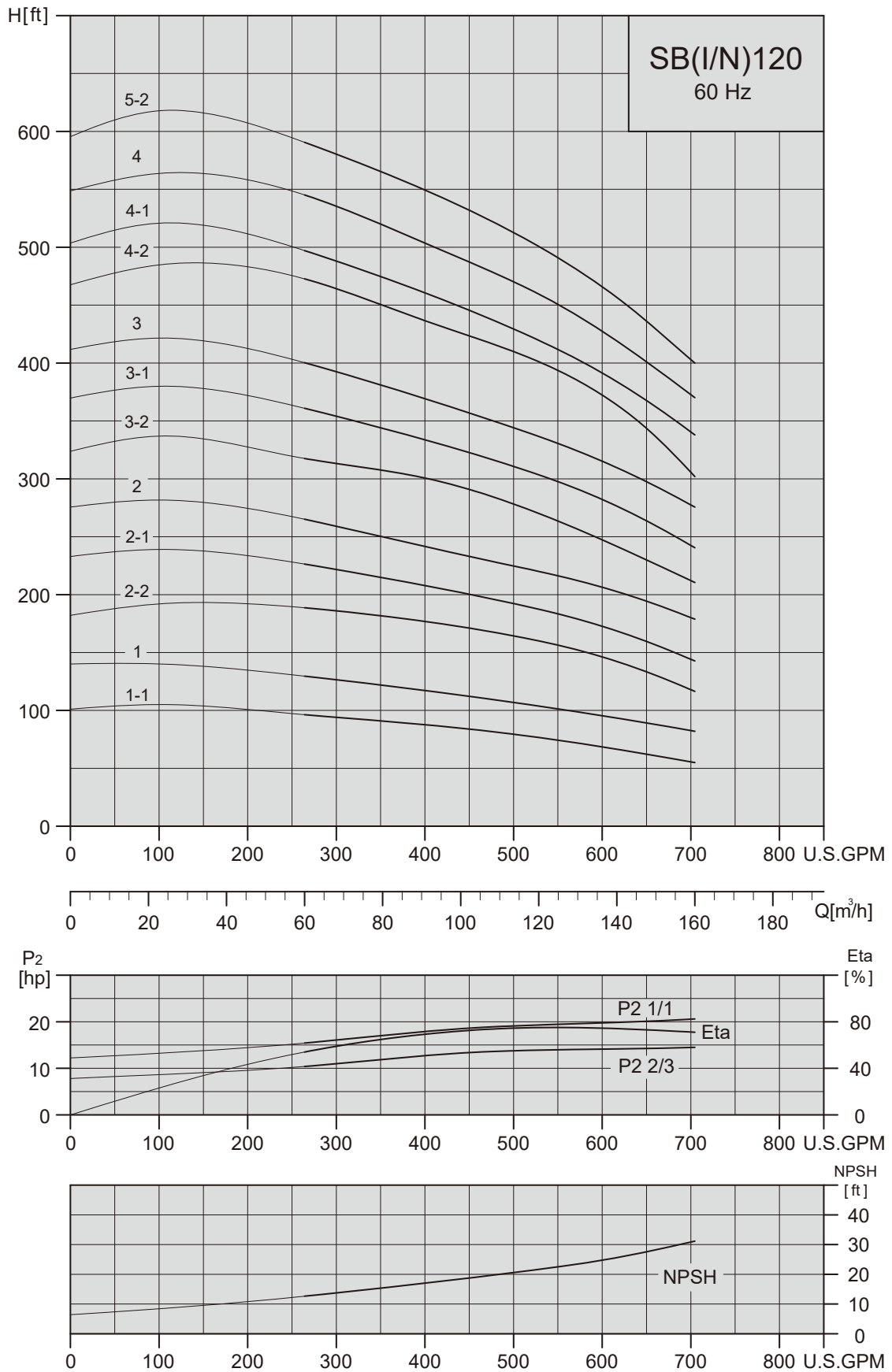

Contents

Vertical Multistage Centrifugal In-line Pumps



Dimension and weights-SB 120

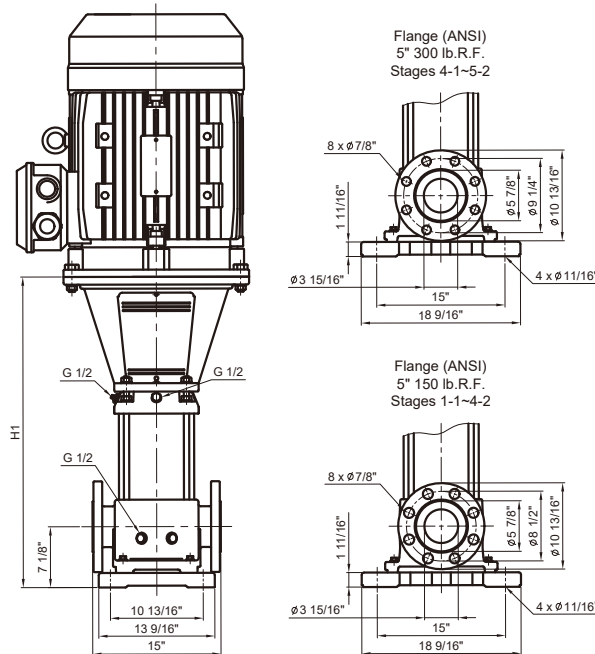

Pump type	Recommend Motor of HP		SBI,SBN			
	P2		NEMA Frame TEFC motors	NEMA Frame ODP motors	Dimension [inch]	Weights[lbs]
	[HP]	[Ph]			ANSI flange	ANSI flange
					H1	
SBI, SBN 90-1-1	15	3	254TC	254TC	26.75	159.3
SBI, SBN 90-1	15	3	254TC	254TC	26.75	159.4
SBI, SBN 90-2-2	25	3	284TSC	284TSC	30.34	172.6
SBI, SBN 90-2-1	30	3	286TSC	284TSC	30.34	172.6
SBI, SBN 90-2	40	3	286TSC	286TSC	30.34	172.7
SBI, SBN 90-3-2	40	3	286TSC	286TSC	33.93	183.8
SBI, SBN 90-3-1	50	3	326TSC	324TSC	33.93	201.3
SBI, SBN 90-3	50	3	326TSC	324TSC	33.93	201.3
SBI, SBN 90-4-2	60	3	364TSC	324TSC	37.36	216.2
SBI, SBN 90-4-1	60	3	364TSC	324TSC	37.36	216.6

Contents

Vertical Multistage Centrifugal In-line Pumps



Dimension and weights-SBI(N) 120

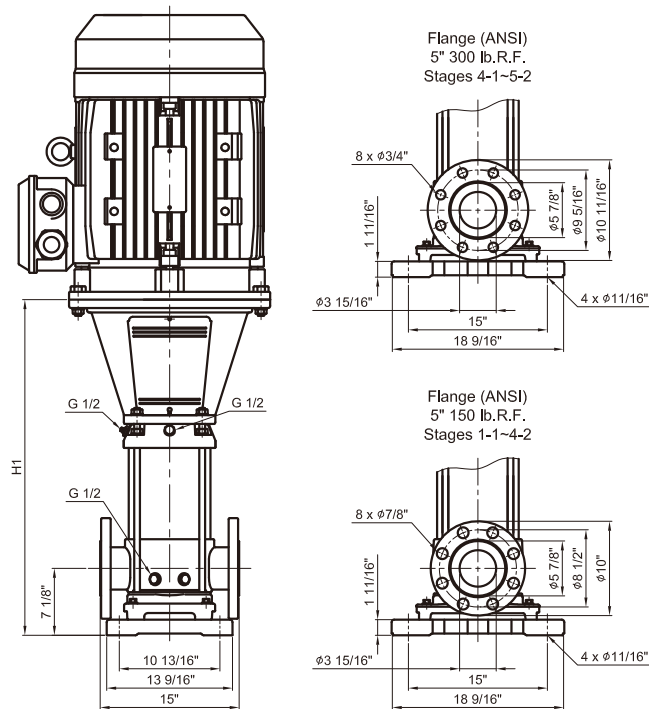

Pump type	Recommend Motor of HP		SBI,SBN			
	P2		NEMA Frame TEFC motors	NEMA Frame ODP motors	Dimension [inch]	Weights[lbs]
	[HP]	[Ph]			ANSI flange	ANSI flange
					H1	
SBI, SBN 120-1-1	20	3	254TC	254TC	32.95	204.4
SBI, SBN 120-1	25	3	284TSC	284TSC	32.95	206.7
SBI, SBN 120-2-2	40	3	286TSC	286TSC	39.07	237.1
SBI, SBN 120-2-1	40	3	286TSC	286TSC	39.07	237.3
SBI, SBN 120-2	50	3	326TSC	324TSC	39.07	255.0
SBI, SBN 120-3-2	60	3	364TSC	324TSC	45.20	276.2
SBI, SBN 120-3-1	60	3	364TSC	324TSC	45.20	276.4
SBI, SBN 120-3	75	3	365TSC	364TSC	45.67	331.4
SBI, SBN 120-4-2	75	3	365TSC	364TSC	51.79	352.9
SBI, SBN 120-4-1	100	3	405TSC	365TSC	51.79	353.0
SBI, SBN 120-4	100	3	405TSC	365TSC	51.79	353.2
SBI, SBN 120-5-2	100	3	405TSC	365TSC	57.91	374.5

Contents

Vertical Multistage Centrifugal In-line Pumps



SB, SBI, SBN 150

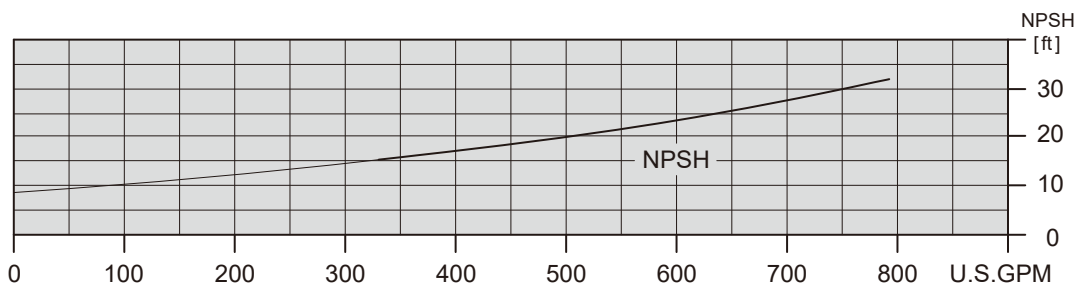
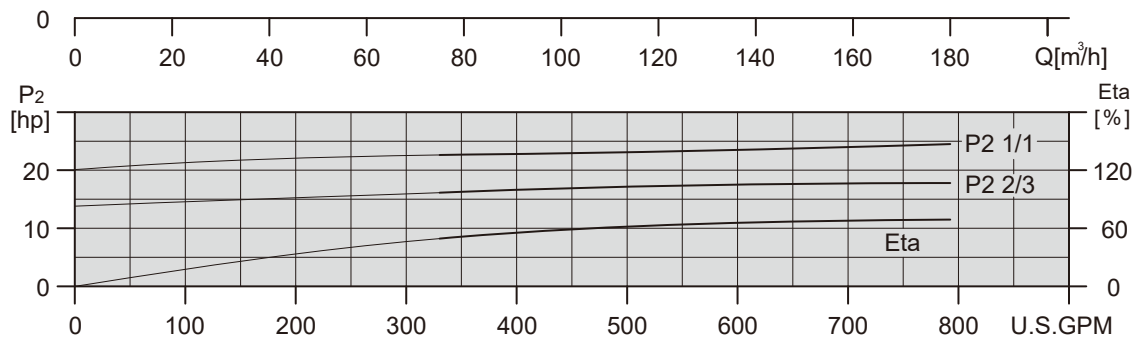
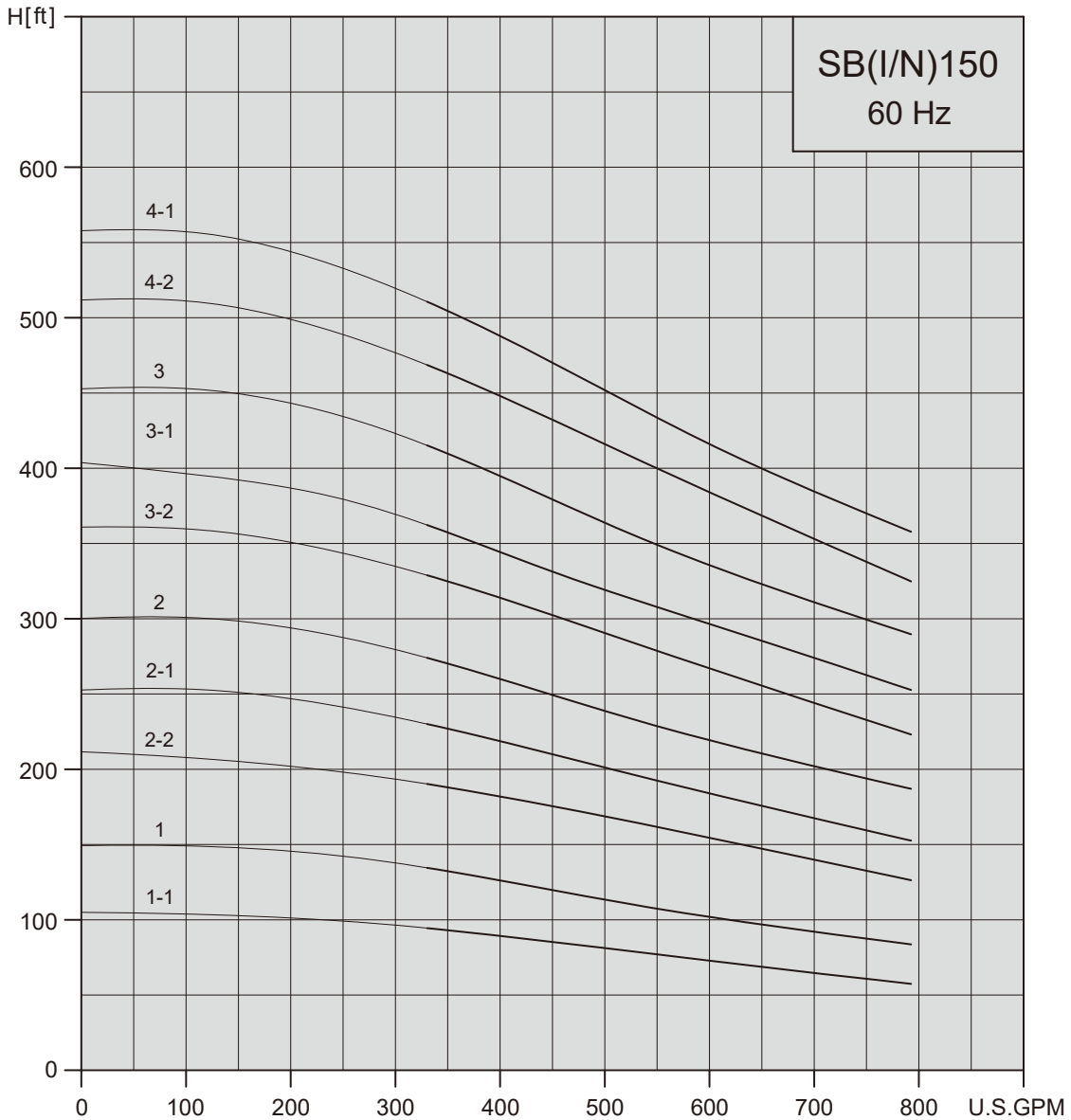

Contents

Vertical Multistage Centrifugal In-line Pumps



STAIRS PUMPS

Dimension and weights-SB 150

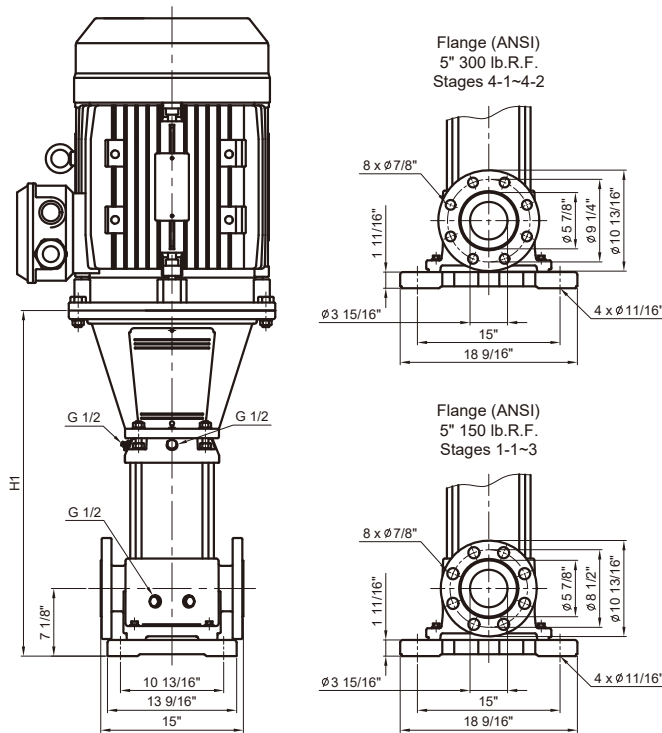

Pump type	Recommend Motor of HP		SB			
	P 2		NEMA Frame TEFC motors	NEMA Frame ODP motors	Dimension [inch]	Weights[lbs]
	[HP]	[Ph]			ANSI flange	ANSI flange
					H1	
SB 150-1-1	25	3	284TSC	284TSC	32.83	249.1
SB 150-1	30	3	286TSC	284TSC	32.83	249.2
SB 150-2-2	40	3	286TSC	286TSC	38.96	270.6
SB 150-2-1	50	3	326TSC	324TSC	38.96	288.0
SB 150-2	60	3	364TSC	324TSC	38.96	288.2
SB 150-3-2	75	3	365TSC	364TSC	45.55	364.1
SB 150-3-1	75	3	365TSC	364TSC	45.55	364.1
SB 150-3	100	3	405TSC	365TSC	45.55	364.2
SB 150-4-2	100	3	405TSC	365TSC	51.67	385.7
SB 150-4-1	100	3	405TSC	365TSC	51.67	385.8

Contents

Vertical Multistage Centrifugal In-line Pumps



Dimension and weights-SBI(N) 150

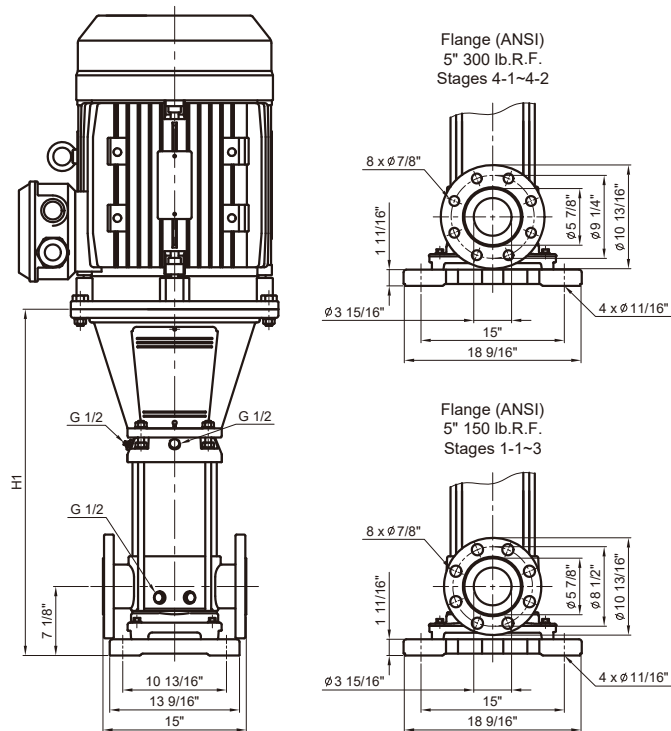

Pump type	Recommend Motor of HP		SB			
	P 2		NEMA Frame TEFC motors	NEMA Frame ODP motors	Dimension [inch]	Weights[lbs]
	[HP]	[Ph]			ANSI flange	ANSI flange
					H1	
SB 150-1-1	25	3	284TSC	284TSC	32.83	249.1
SB 150-1	30	3	286TSC	284TSC	32.83	249.2
SB 150-2-2	40	3	286TSC	286TSC	38.96	270.6
SB 150-2-1	50	3	326TSC	324TSC	38.96	288.0
SB 150-2	60	3	364TSC	324TSC	38.96	288.2
SB 150-3-2	75	3	365TSC	364TSC	45.55	364.1
SB 150-3-1	75	3	365TSC	364TSC	45.55	364.1
SB 150-3	100	3	405TSC	365TSC	45.55	364.2
SB 150-4-2	100	3	405TSC	365TSC	51.67	385.7
SB 150-4-1	100	3	405TSC	365TSC	51.67	385.8



Flo Fab inc.

Company
860 boulevard industriel, Bois-Des-Filion, QC
J6Z 4V7, Canada
Tél: 450-621-2995
Fax: 450-621-4995
Email: flofab@flofab.com