

Pressure Vessels

BT Series

Replaceable Bladder Expansion Tank with Bottom System Connection

RDT Series

Fixed Bladder Expansion Tank

SEP Series

Vortex - Tangential Air Separator

ADSR/AD Series

In-Line Air/Dirt Separator (With or Without Strainer)

RLU/RWU Series

Hot Water Storage Tank

CBT Series

Buffer Tank



www.flofab.com

003-cat-2019-pv

TABLE OF CONTENT

RDT EXPANSION TANKS.....	2
BT EXPANSION TANKS.....	3
BT & RDT EXPANSION TANKS.....	4
INSTALLATION OF TANKS.....	5
SEP VORTEX TANGENTIAL AIR SEPARATOR.....	6-8
ADSR/AD & ADSF IN-LINE AIR/DIRT SEPARATOR.....	9-14
RLU HOT WATER STORAGE TANK.....	15-20
RWU HOT WATER STORAGE TANK.....	21-24
CBT BUFFER TANK.....	25-26

HISTORY

Flo Fab was established in 1981 by Denis Gauvreau who created and developed the product line, which is constantly being perfected by Marc Gauvreau and a team of professional engineers and designers. It is a combination of existing designs from several renowned products and the innovative ideas of a new generation professionals.

Through the years, Flo Fab has acquired several companies and service entities including: AQUA-PROFAB (ASME Tanks manufacturer), MÉNARD, LÉONARD ÉLECTRIQUE, PMA. Moreover, Flo Fab also purchased equipment, fabrication designs and patterns from IDEALCO, a manufacturer of shell and tube type heat exchangers.

The after-sales services, sales, engineering, R&D, production, quality control, accounting and administration departments of all the above companies share the same location.

In December 2014, Marc Gauvreau, son of the founder, acquired all of the company's shares. Flo Fab and is constantly investing in new state-of-the-art innovations, new products like the XRI series and Prefab Skid for Hydronic Heating & cooling system and pumping systems. This has allowed Flo Fab to retain our competent and qualified staff of professionals with a variety of specialized skills that continually work on improving our existing products and adding new engineered solutions that exceed customers' expectations .

Flo Fab has grown quite rapidly and now proudly offers of a wide range of products available directly from one manufacturer. This includes pumps and pump packages, tanks, heat exchangers and hydronic accessories. This allows each project's stakeholders to enjoy economical savings, peace of mind, best value for their investment and optimized total cost of ownership.



• Product Specifications RDT

Flo Fab type RDT expansion tanks are designed for use in Hydronic heating/cooling systems to absorb the expansion force resulting from the changes in temperature of the heating/cooling fluid. As the system fluid expands, it is forced into the precharged tank to the maximum system pressure. The precharged air cushion then forces the fluid back into the system as it contracts. The extra heavy butyl diaphragm keeps the fluid permanently isolated from the precharged air cushion. This arrangement eliminates water logging and absorption of air into the system. It also helps prevent air bound terminal units, excessive corrosion, inefficient balancing and pump cavitation over the life of the system. The large acceptance volume allows maximum storage and reduction of up to 80% in tank size. Energy consumption is reduced by eliminating unnecessary system water volume.

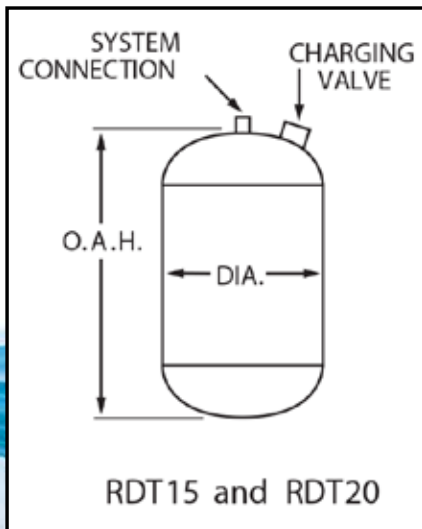

RDT Expansion Tank

ASME fixed diaphragm type precharged expansion tanks for commercial and industrial heating/cooling systems available in sizes from 7.8 gallons to 211 gallons.

- ASME Section VIII construction and label
- Heavy duty butyl diaphragm
- Permanent separation of air and water
- Smaller sizes for easier handling, and saves space and installation costs
- Can be manifolded for more capacity
- Factory precharged 12 PSI and field adjustable

✓	Model Number	Tank Volume (gal.)	Acceptance Volume (gal.)	N.P.T System Connection	Max Oper. Pressure (psi)	DIMENSIONS		Approx. Weight (lbs)
						Diameter (in.)	Height (in.)	
	RDT 15	7.8	6.3	3/4"	150	12	19	42
	RDT 20	11	8.8	3/4"	150	12	25	52
	RDT 40	25	20.2	1"	150	16	33	84
	RDT 60	35	28	1"	150	16	44	97
	RDT 80	45	36	1"	125	20	38	148
	RDT 100	60	48.5	1"	125	20	49	175
	RDT 120	70	56.5	1 1/2"	125	24	46	259
	RDT 144	80	65	1 1/2"	125	24	49	268
	RDT 180	90	73	1 1/2"	125	24	52	283
	RDT 200	115	93	1 1/2"	125	24	66	325
	RDT 240	140	113.5	1 1/2"	125	24	78	362
	RDT 260	158	128	1 1/2"	125	30	63	591
	RDT 280	211	171	1 1/2"	125	30	81	752

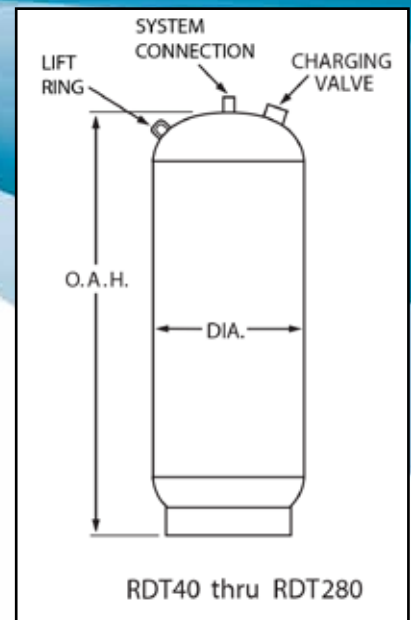



● Product Specifications BT

BT Expansion Tank

ASME replaceable diaphragm type expansion tanks for commercial and industrial heating/cooling systems. Space saving tank comes in sizes of 10 to 3963 gallons.

- ASME Section VIII construction and label
- Permanent separation of air and water
- Never waterlogs
- Water is "in the bag." Steel tank never touches water and is not subject to corrosion
- Replacement diaphragm
- Smaller sizes for easier handling, and saves space and installation costs



125 P.S.I. operating pressure 240°F- maximum temperature at tank factory precharged 12 P.S.I.
Prime painted exterior finish

✓	Model Number	Tank and Acceptance Vol. (Gals)	Dimensions		N.P.T. System Conn.	N.P.T. Aux. Conn.	Shipping Weight Pounds
			Diame-ter (in.)	Height (in.)			
	BT-12	10	12	25	3/4"	-	40
	BT-25	10	12	25		-	40
	BT-35	10	12	25		-	40
	BT-50	13	14	25		-	50
	BT-75	23	16	37	1"	1/2"	90
	BT-100	35	20	37			125
	BT-130	35	20	37			125
	BT-132	35	20	37			125
	BT-160	53	24	43	1 1/2"	3/4"	210
	BT-200	53	24	43			210
	BT-250	79	24	55			225
	BT-400	106	30	49			300
	BT-500	132	30	57		335	
	BT-600	158	30	65		360	
	BT-800	211	32	76		475	
	BT-1000	264	36	74		-	710
	BT-1200	317	36	86		-	720
	BT-1400	370	36	99		-	875
	BT-1600	422	48	72	-	1100	
	BT-2000	528	48	85	-	1280	
	BT-2500	660	48	102	2	-	1435
	BT-3000L	792	48	122		-	1550
	BT-3000S	792	60	80		-	2169
	BT-4000	1056	60	102		-	2638
	BT-5000	1320	60	125	-	3246	
	BT-7500	1980	72	127	3	-	4005
	BT-10000	2640	72	159		-	4845
	BT-15000	3963	72	233		-	5925



Product Specifications

BT

OPTIONS :

- Sight glass
- Antiseismic brackets
- External epoxy Finish
- Horizontal with saddles floor mounting
- Horizontal with straps ceiling mounting
- Off centered system connection for Hydropneumatic tank
- 304 Stainless steel connection for Hydropneumatic tank (For Potable Water)
- 316 Stainless steel connection for Hydropneumatic tank
- 150 PSI rating
- 200 PSI rating
- 500 PSI rating

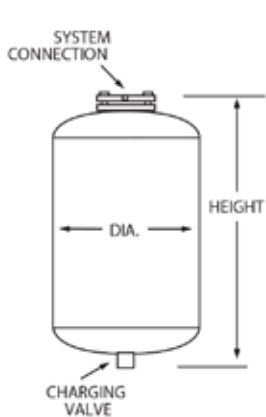

BT12 and BT50

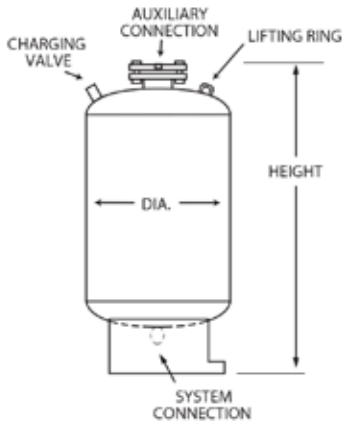

BT75 and BT800

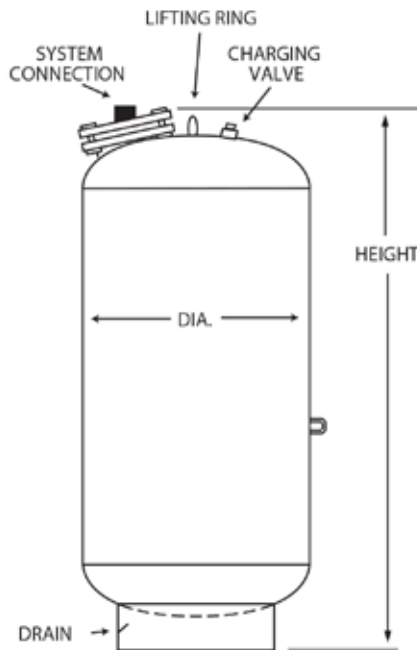

BT 1000 thru
BT1500 0

Optional Saddles

Size	A	B	Weight
12	10	3	18
14	11	3	19
16	13	3	21
20	14	4	25
24	17	4	28
30	21	5	38
36	25	5	52

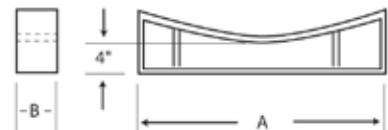

• Installation Details

SIMPLE INSTALLATION

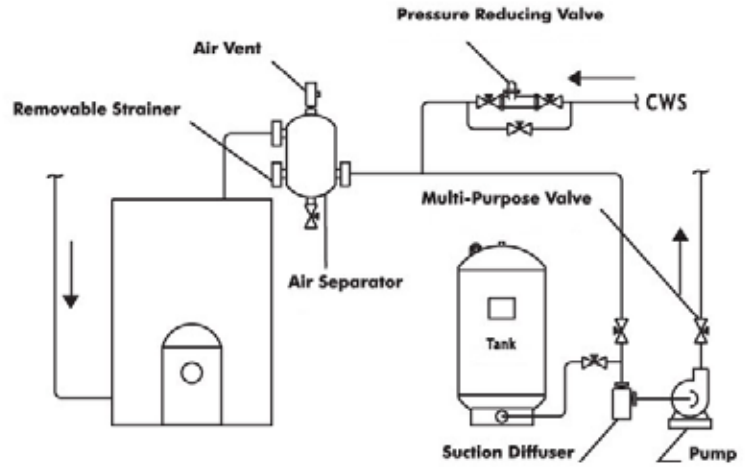

HORIZONTAL INSTALLATION (OPTIONAL)

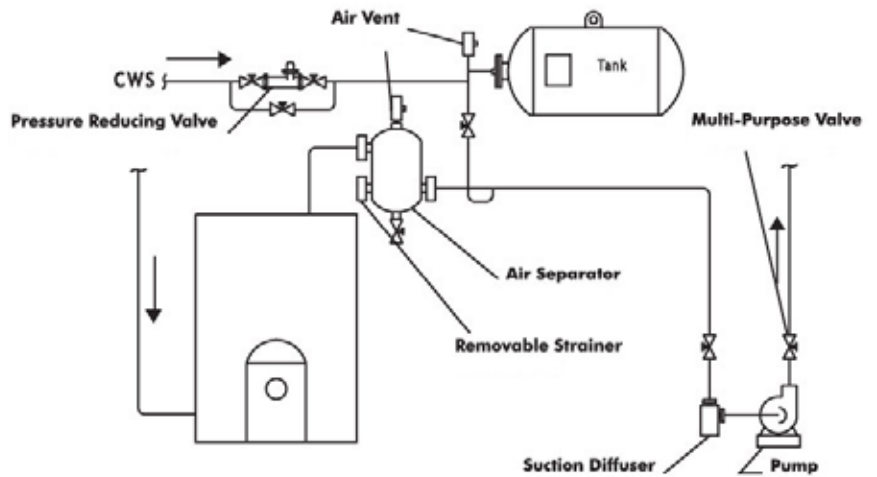

MULTI INSTALLATION

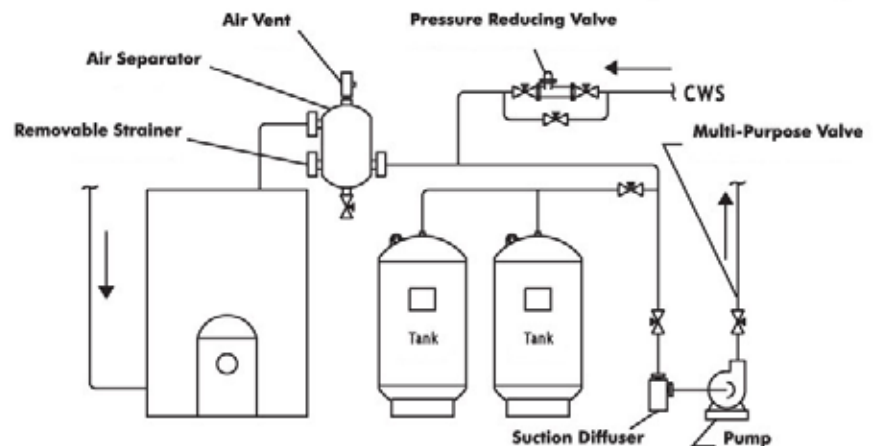



Product Specifications

SEP

Flo Fab SEP ASME Vortex type Air Separators eliminate air quickly and efficiently from open and closed loop heating/cooling systems. Water enters and exits through unique "tangential" connections, which promote a low velocity swirling effect in the center of the unit. Natural centrifugal forces allow the heavier air-free water to move toward the outer edges while entrained air is captured within the "eye" of the vortex and released out of the top of the separator. The bubble-free water then exits near the bottom of the unit, protecting the systems against the noise, corrosion, and damage commonly caused by entrained air. SEP units also include system strainer.

Performance Limitations

Maximum Design Temperature: 450°F
 Maximum Design Pressure: 150 PSI (2"-8" inlet/outlet)
 125 PSI (10"-30" inlet/outlet)
 *200 & 250 PSIG available

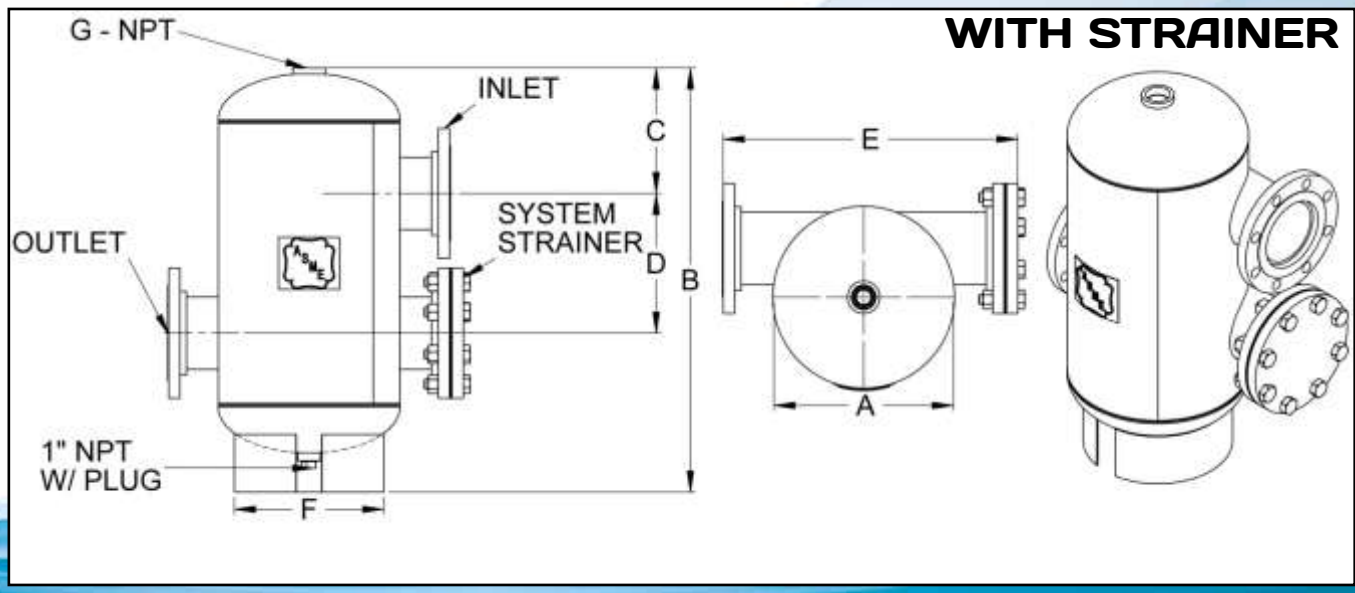

Dimensions and Weights

✓	Model Number	Dimensions in inches								Approx. Shipping Wt (lbs)
		Connection Size	A	B	C	D	E	F	G	
	SEP-2-S	2 NPT	12	24 1/2	6 1/3	8 1/2	16 5/8	9 1/2	1 1/4	48
	SEP-2.5-S	2.5 NPT			6 7/8					8
	SEP-3-S	3		25	8	19 3/4	92			
	SEP-4-S	4	14	32	9 1/8	10 3/4	21 3/4	11 1/2	1 1/2	99
	SEP-5-S	5								132
	SEP-6-S	6	20	44	13 1/4	14 1/2	28	18		190
	SEP-8-S	8								308
	SEP-10-S	10	30	60 1/2	19	20	41	24		606
	SEP-12-S	12								812
	SEP-14-S	14	36	78	22	31 1/2	46 3/8	30		1138
	SEP-16-S	16	48	108	30	40	60	38	2	2520
	SEP-18-S	18	54	124	33	50	66	44		2973
	SEP-20-S	20	60	138	35	60	72	50		3904
	SEP-22-S	22	66	150	38	66	78	56		4684
	SEP-24-S	24	66						5003	
	SEP-30-S	30	72						68	84

Other size available upon request.

Product Specifications

SEP

Flo Fab SEP ASME Vortex type Air Separators eliminate air quickly and efficiently from open and closed loop heating/cooling systems. Water enters and exits through unique "tangential" connections, which promote a low velocity swirling effect in the center of the unit. Natural centrifugal forces allow the heavier air-free water to move toward the outer edges while entrained air is captured within the "eye" of the vortex and released out of the top of the separator. The bubble-free water then exits near the bottom of the unit, protecting the systems against the noise, corrosion, and damage commonly caused by entrained air. SEP units also include system strainer.

Performance Limitations

Maximum Design Temperature:
450°F
Maximum Design Pressure:
150 PSI (2"-8" inlet/outlet)
125 PSI (10"-30" inlet/outlet)
*200 & 250 PSIG available

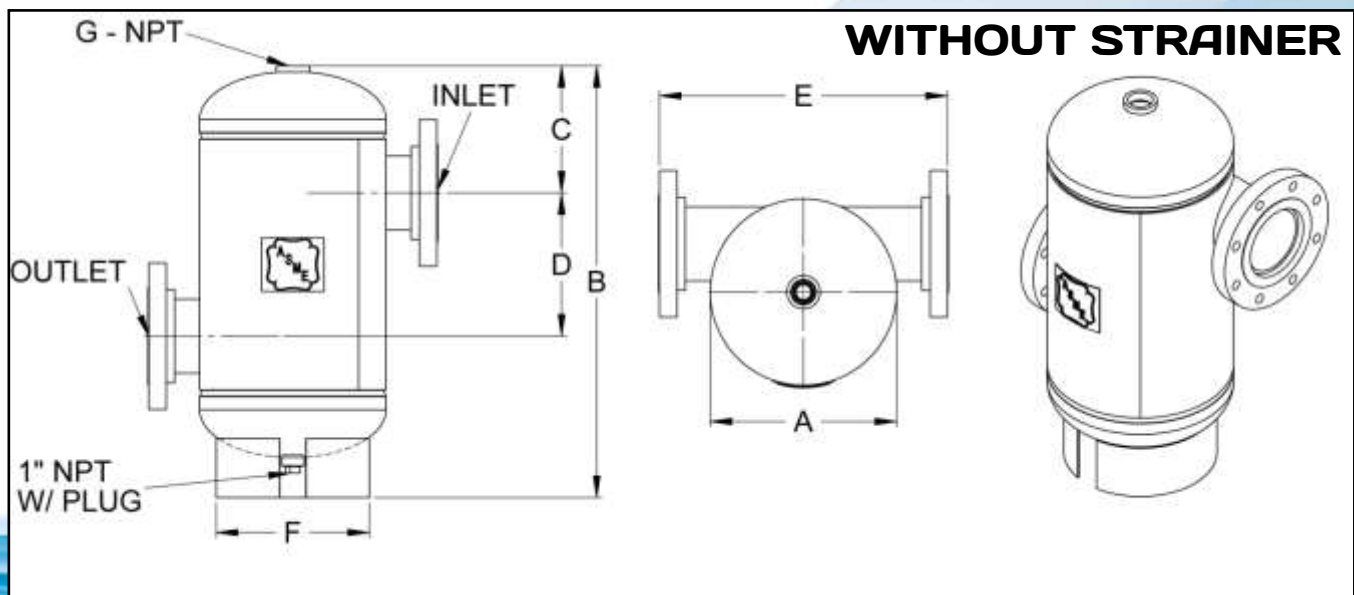

Dimensions and Weights

✓	Model Number	Dimensions in inches								Approx. Shipping Wt (lbs)				
		Connection Size	A	B	C	D	E	F	G					
	SEP-2-S	2 NPT	12	22 1/2	5 1/2	8 1/2	16 5/8	9 1/2	1 1/4	34				
	SEP-2.5-S	2.5 NPT			6 1/4	8	19 3/4			37				
	SEP-3-S	3			9 1/8	10 3/4	21 3/4			45				
	SEP-4-S	4	14	32	13 1/4	14 1/2	28	18	1 1/2	80				
	SEP-5-S	5								19	20	41	24	125
	SEP-6-S	6	20	44	19	20	41	24	2	175				
	SEP-8-S	8								31 1/2	46 3/8	30	210	
	SEP-10-S	10								33	50	66	44	460
	SEP-12-S	12	30	60 1/2	35	60	72	50	2	577				
	SEP-14-S	14								66	78	96	56	850
	SEP-16-S	16								78	108	126	66	1858
	SEP-18-S	18	150	38	66	84	66	66	2	2490				
	SEP-20-S	20								78	124	152	78	3346
	SEP-22-S	22								84	138	166	84	3879
	SEP-24-S	24	72	150	38	66	84	66	2	4211				
	SEP-30-S	30								84	150	180	96	7260

Other size available upon request.



● Performance Curves SEP

Pressure Drop Charts Comparing Feet of Head Versus Flow in Gallons Per Minute for Tangential Flo Fab Air Separators...

With Strainer

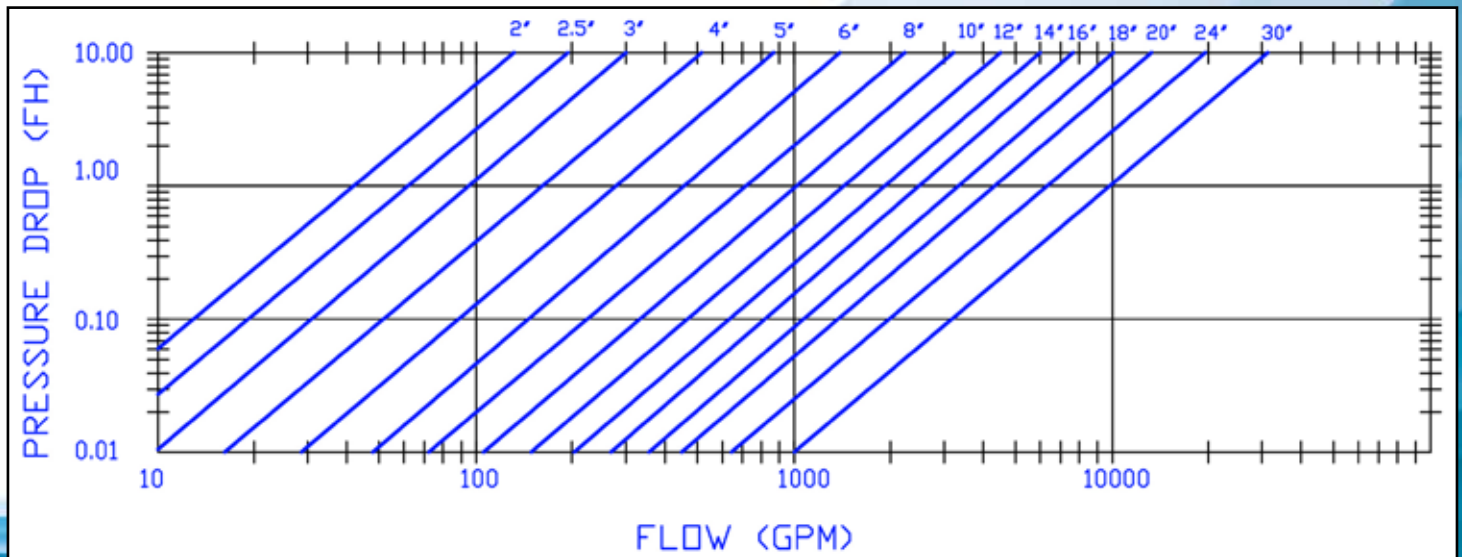

Without Strainer

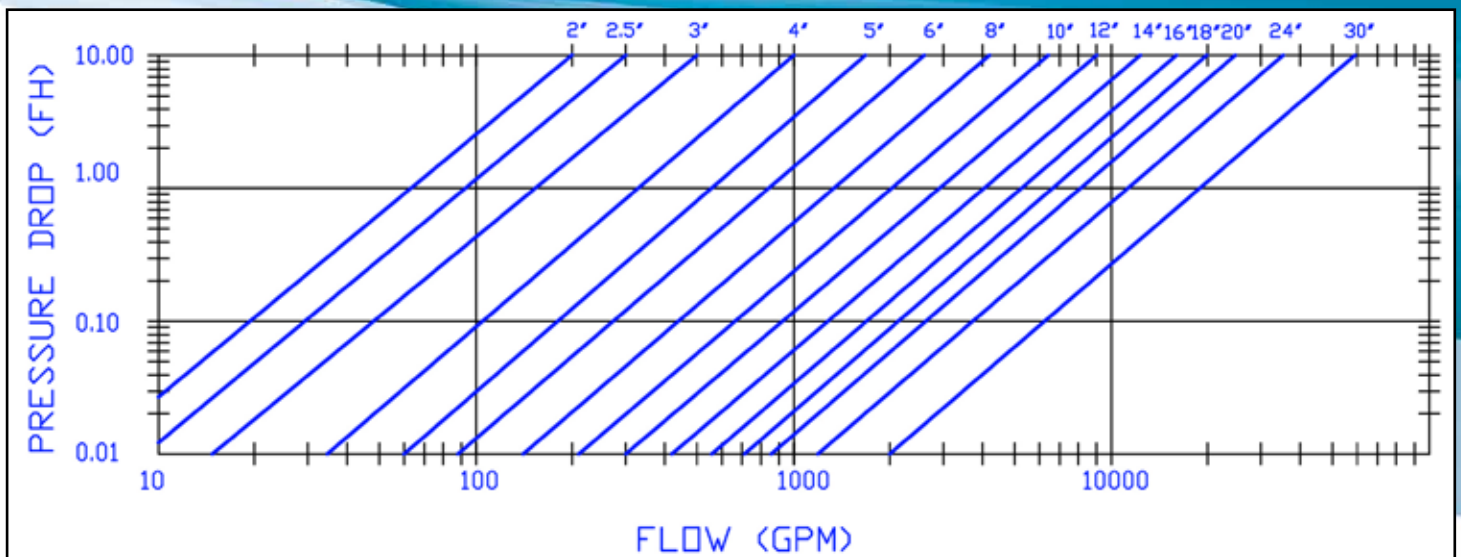



Product Specifications

ADSR

Furnish and install, as shown on plans, a ADSR- _____ Air & Dirt Separator as manufactured by FloFab. Each separator must be designed with a blow down valve, skim valve, and automatic air vent. The separator must also utilize in its design a stainless steel coalescing medium to aid in the separation of air and dirt in the systems entrained water. The separator must be constructed in accordance with most recent addendum of Section VIII Division 1 of the ASME Boiler and Pressure Vessel Code and shall be constructed and stamped for 125 PSI working pressure @ 250°F.

Flo Fab ADSR series Air & Dirt Separators are designed to eliminate entrained air and separate debris associated with start-up and maintenance of any hydronic systems. The design incorporates a skim valve, used to eliminate floating debris, removable end cover for coalescing medium access, and an air vent to automatically release air from the separator.

Performance Limitations

Maximum Design Temperature:
250°F
Maximum Design Pressure:
125 PSIG*

*150, 200 & 250 PSIG available

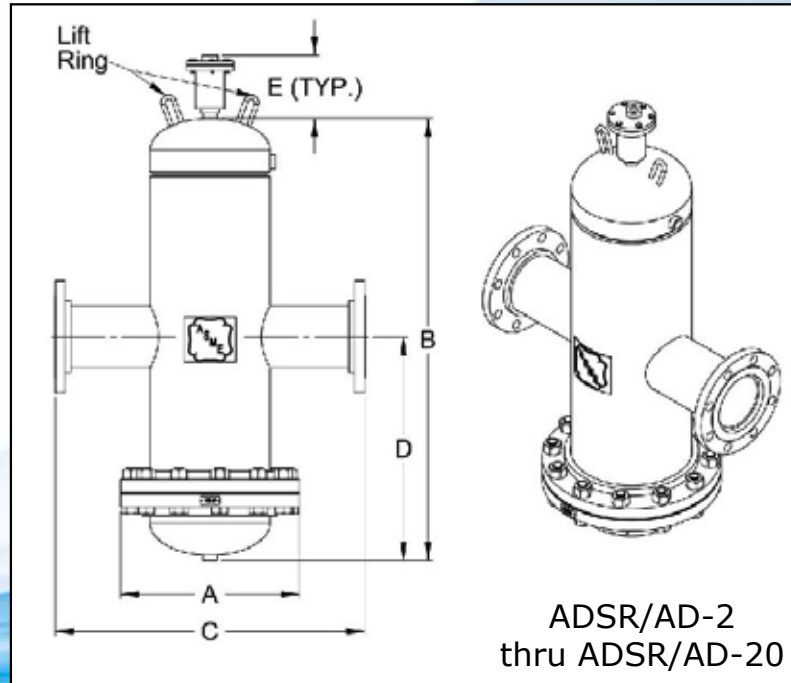

ADSR/AD-2 thru ADSR/AD-20

✓	Model Number	Dimensions in inches					Approx. Shipping Wt (lbs)	Flow GPM	
		Connection Size	A	B	C	D			
	ADSR-2	2	9	23	15 1/4	11 1/2	8 5/8	100	69
	ADSR-2-NPT				9			90	69
	ADSR-2.5	2.5	10	29	15 3/4	125		108	
	ADSR-2.5-NPT				10 1/2	115		108	
	ADSR-3	3	11	29	20 1/4	14 1/2		150	144
	ADSR-3-NPT				12 3/4			130	144
	ADSR-4	4	13 1/2	29	20 5/8	19 1/2		250	255
	ADSR-4-NPT				15			210	255
	ADSR-5	5	16	39	27 3/4	19 1/2		310	398
	ADSR-6	6	19					375	570
	ADSR-8	8	23 1/2	49	33 5/8	24 1/2		700	945
	ADSR-10	10	27 1/2	65	37 1/2	32 1/2		1000	1440
	ADSR-12	12	32	76	42 1/2	38	1500	2100	
	ADSR-14	14	30	78	48	39	1800	6500	
	ADSR-16	16	30	78	48	39	1950	2200	
	ADSR-18	18	36	78	48	39	2700	10 000	
	ADSR-20	20	42	84	56	42	2900	3500	

Other size available upon request.



Product Specifications

ADSR HV

Furnish and install, as shown on plans, a ADSR-_____ -HV High Velocity Air & Dirt Separator as manufactured by Flo Fab. Each separator must be designed with a blow down valve, skim valve, and automatic air vent. The separator must also utilize in its design a stainless steel coalescing medium to aid in the separation of air and dirt in the systems entrained water. The separator must be constructed in accordance with most recent addendum of Section VIII Division 1 of the ASME Boiler and Pressure Vessel Code and shall be constructed and stamped for 125 PSI working pressure @ 250°F.

Flo Fab ADSR-HV (High Velocity) series Air & Dirt Separators are designed to eliminate entrained air and separate debris associated with start-up and maintenance of any hydronic systems. The design incorporates a skim valve, used to eliminate floating debris, removable end cover for coalscing medium access, and an air vent to automatically release air from the separator.

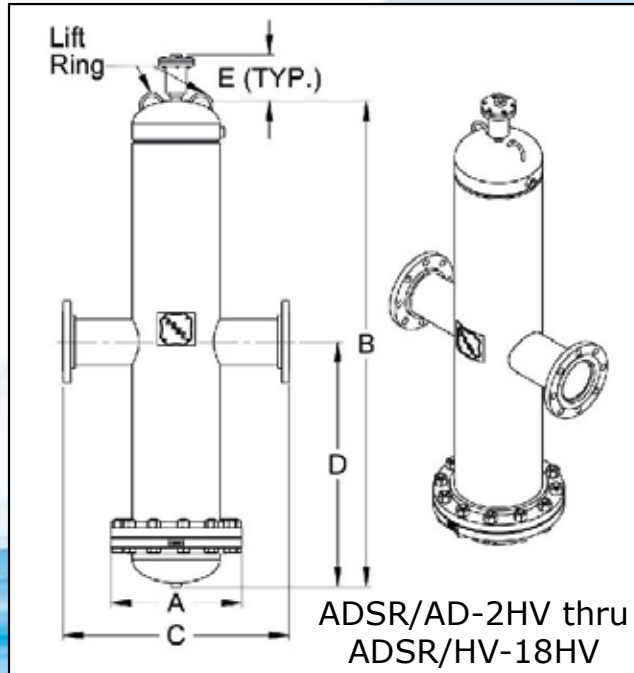

Performance Limitations

Maximum Design Temperature:
250°F
Maximum Design Pressure:
125 PSIG*
*150, 200 & 250 PSIG available

√ Model Number	Dimensions in inches						Approx. Shipping Wt (lbs)	Flow GPM	
	Connection Size	A	B	C	D	E			
ADSR-2HV	2	9	33	15 1/8	16 1/2	8 5/8	110	105	
ADSR-2HV-NPT				9			100	105	
ADSR-2.5HV	2.5	10		15 3/4			140	155	
ADSR-2.5HV-NPT				10 1/2			125	155	
ADSR-3HV	3	11	42	20 1/4	21		175	225	
ADSR-3HV-NPT				12 3/4			155	225	
ADSR-4HV	4	13 1/2		20 5/8			29 1/2	275	405
ADSR-4HV-NPT				15				235	405
ADSR-5HV	5	16	59	27 3/4	29 1/2		475	630	
ADSR-6HV	6	19					525	910	
ADSR-8HV	8	23 1/2	75	33 5/8	37 3/4		825	1610	
ADSR-10HV	10	27 1/2	92	37 1/2	46		1275	2450	
ADSR-12HV	12	32	110	42 1/2	55	2050	3500		
ADSR-14HV	14	30	110	48	55	2880	4100		
ADSR-16HV	16	32	110	48	55	2600	5500		
ADSR-18HV	18	36	110	52	55	3010	7100		
ADSR-20HV	20	42	110	56	55	3770	8800		

Other size available upon request.



Performance Curves ADSR

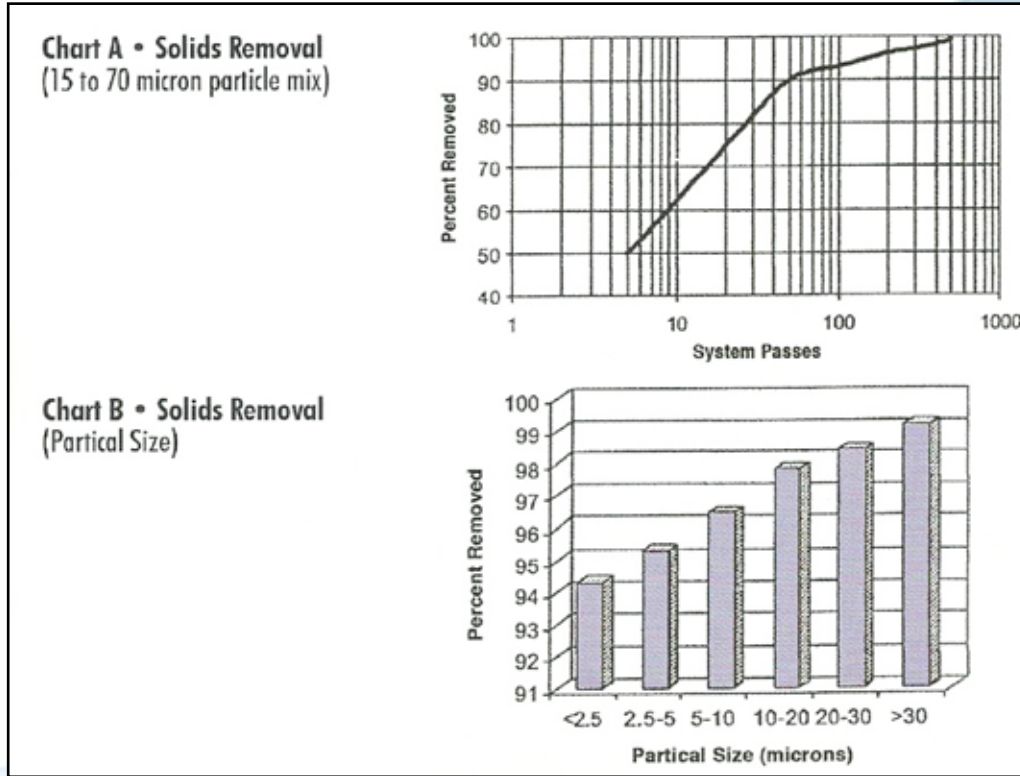

AIR REMOVAL

independent third party laboratory testing has concluded that Flo Fab ADSR/AD Air & Dirt separator will eliminate air to a level at greater than 99.5%. This testing was accomplished with measurements of dissolved oxygen and observation at bubbles over time. Results concluded that within 15 to 45 minutes, 50% at the dissolved oxygen was removed. With sufficient time (less than two hours), the dissolved oxygen level was reduced to less than 0.1%

DIRT REMOVAL

Dirt flowing with the system water is diverted to the ADSR/AD Air & Dirt Separator As this flow enters the unit, dirt particle removal (dependent an system cycles) is measured according to particle size Results from testing are revealed in Charts A and 8 below. From Chart A. 90% of dirt lin the I5 to 70 micron size) is separated and diverted to the bottom of the Wess-Vent. With continual system cycling dirt removal will approach 99%. Chart B reveals the particle size removal percentage in 24 hours of operation For example more than 97% of particles in the 10 to 20 micron size range were separated.



Product Specifications

ADSF

Furnish and install, as shown on plans, a ADSF- _____ -N Air & Dirt Separator as manufactured by Flo Fab. Each separator must be designed with a blow down valve, skim valve, and automatic air vent. The separator must also utilize in its design a stainless steel coalescing medium to aid in the separation of air and dirt in the systems entrained water. The separator must be constructed in accordance with most recent addendum of Section VIII Division 1 of the ASME Boiler and Pressure Vessel Code and shall be constructed and stamped for 125 PSI working pressure @ 250°F.

Flo Fab ADSF-N (Non-Removable) series Air & Dirt Separators are designed to eliminate entrained air and separate debris associated with start-up and maintenance of any hydronic systems. The design incorporates a skim valve, used to eliminate floating debris, and an air vent to automatically release air from the separator.

Performance Limitations

Maximum Design Temperature:
250°F
Maximum Design Pressure:
125 PSIG*

*150, 200 & 250 PSIG available

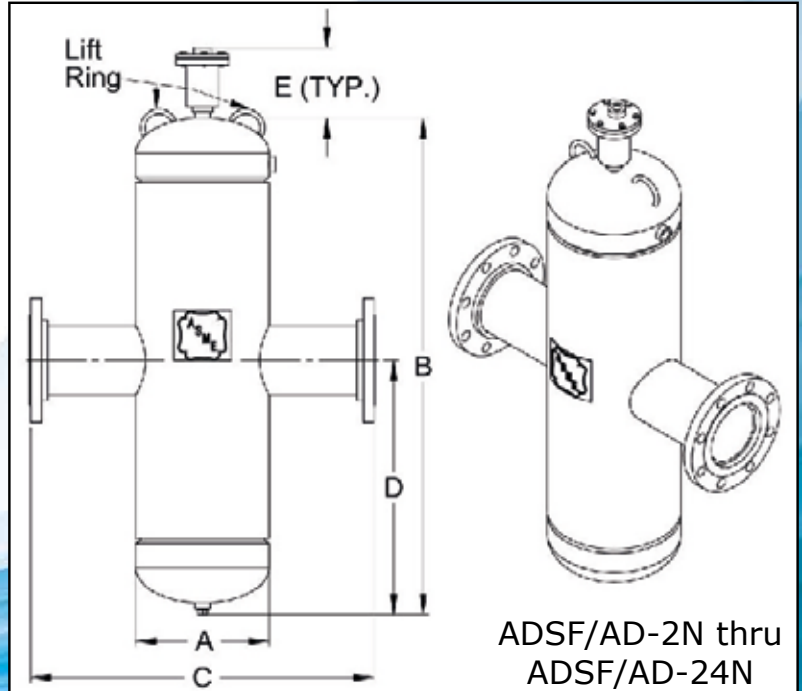

Dimensions and Weights

✓	Model Number	Dimensions in inches					Approx. Shipping Wt (lbs)	
		Connection Size	A	B	C	D		
	ADSF-2N	2	4 1/2	23	15 1/4	11 1/2	8 5/8	
	ADSF-2N-NPT				9			
	ADSF-2.5N	15 3/4						
	ADSF-2.5N-NPT	2.5	5 1/2	10 1/2	14 1/2	108		
	ADSF-3N			20 1/4		144		
	ADSF-3N-NPT	3	6 1/2	12 3/4	19 1/2	144		
	ADSF-4N			20 5/8		255		
	ADSF-4N-NPT	4	8 1/2	15	24 1/2	255		
	ADSF-5N			10		398		
	ADSF-6N	5	10	39	27 3/4	19 1/2		570
	ADSF-8N	6	12					49
	ADSF-10N	8	16	65	33 5/8	24 1/2		1440
	ADSF-12N	10	20	76	37 1/2	32 1/2	2100	
	ADSF-14N	12	24	73	42 1/2	38	2107	
	ADSF-16N	14	30	79 13/16	43 3/8	33	2790	
	ADSF-18N	16	30	108	44 1/2	34 1/8	3569	
	ADSF-20N	18	36	120	56	55	4445	
	ADSF-24N	20	42	144	61 3/8	61	6843	
		24	48		72	73		

Other size available upon request.



Product Specifications

ADSF HV

Furnish and install, as shown on plans, a ADSF- _____ -N-HV High Velocity Air & Dirt Separator as manufactured by Flo Fab Company. Each separator must be designed with a blow down valve, skim valve, and automatic air vent. The separator must also utilize in its design a stainless steel coalescing medium to aid in the separation of air and dirt in the systems entrained water. The separator must be constructed in accordance with most recent addendum of Section

VIII Division 1 of the ASME Boiler and Pressure Vessel Code and shall be constructed and stamped for 125 PSI working pressure @ 250°F.

Flo Fab ADSF-N-HV (Non-Removeable High Velocity) series Air & Dirt Separators are designed to eliminate entrained air and separate debris associated with start-up and maintenance of any hydro-nic systems. The design incorporates a skim valve, used to eliminate floating debris, and an air vent to automatically release air from the separator.

Performance Limitations

Maximum Design Temperature:
250°F
Maximum Design Pressure:
125 PSIG*

*150, 200 & 250 PSIG available

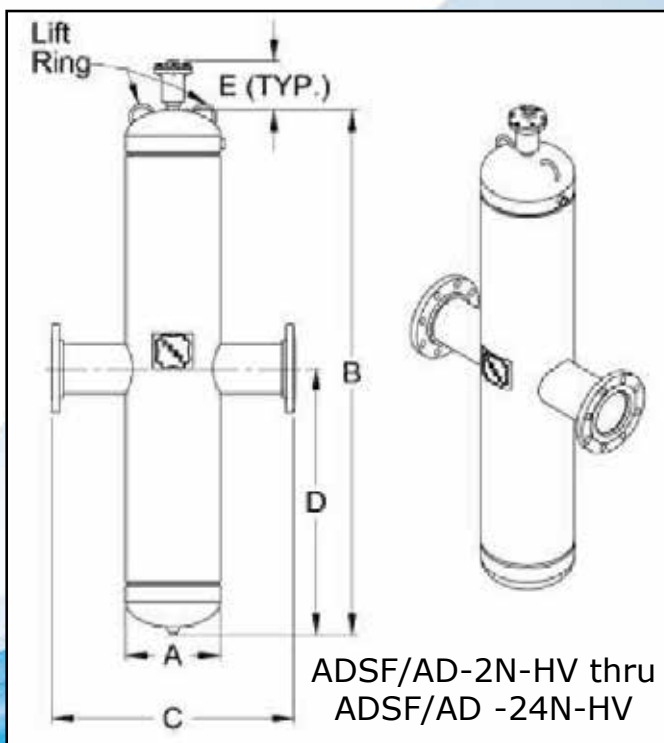

Other size available upon request.

√	Model Number	Dimensions in inches					Approx. Shipping Wt (lbs)	
		Connection Size	A	B	C	D		E
	ADSF-2N-HV	2	4 1/2	33	15 3/4	16 1/2	8 5/8	105
	ADSF-2N-HV-NPT				9			105
	ADSF-2.5N-HV	2.5	5 1/2		15 3/4			155
	ADSF-2.5N-HV-NPT				10 1/2			155
	ADSF-3N-HV	3	6 1/2	42	20 1/4	21	8 5/8	225
	ADSF-3N-HV-NPT				12 3/4			225
	ADSF-4N-HV	4	8 1/2		20 5/8			405
	ADSF-4N-HV-NPT				14 3/4			405
	ADSF-5N-HV	5	10	59	27 3/4	29 1/2	8 5/8	630
	ADSF-6N-HV	6	12					910
	ADSF-8N-HV	8	16	75	33 5/8	37 1/2	1610	
	ADSF-10N-HV	10	20	92	37 1/2	46	2450	
	ADSF-12N-HV	12	24	110	42 1/2	55	3500	
	ADSF-14N-HV	14	36	102 15/16	49 5/8	53 1/4	13	4703
	ADSF-16N-HV	16			51			6264
	ADSF-18N-HV	18			162			56
	ADSF-20N-HV	20	42	180	61 3/8	91	14	9978
	ADSF-24N-HV	24	48	216	72	109	16	14555



● Performance Curves

ADSF

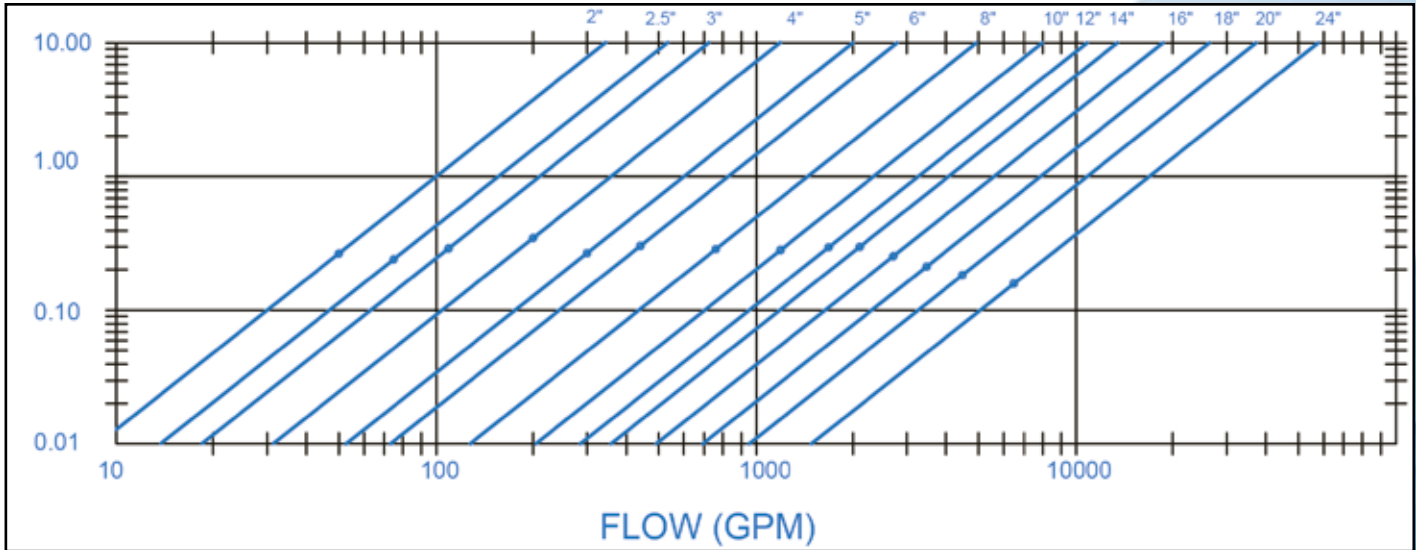

ADSFHV

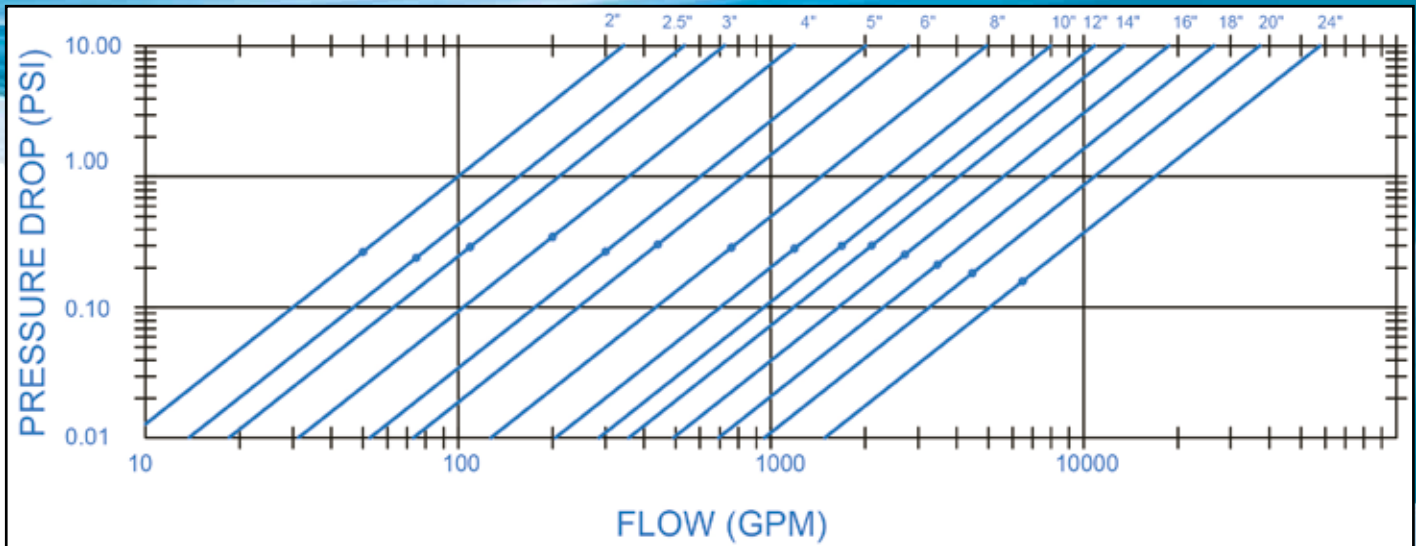



● Product Specifications RLUV

Flo Fab Tank maintains a large selection of standard Large volume hot water storage tanks in inventory which are available for quick ship. Inventory gallon sizes range from 210 gallon up to 1000 gallons. All tanks are vertical/horizontal, glass lined with oxide primer. Refer to our submittal pages for details on tank fitting configuration. Manways are required on all tanks OVER 36" diameter and our pricing reflects that requirement. Manways are optional on 36" diameter and below. All bare vertical tanks come standard with lifting lugs. Each tank is hydro-tested and independently inspected as ASME regulations require. Need more than what is available in our standard sizes? We can build to your specifications. Fitting changes, flanges, linings and exterior finishes, high pressures are all available but current lead times will apply. Please visit our Get A Quote page and tell us what you're looking for. When ordering or requesting a quotation, please let us know the number of fittings or nozzles, operating pressure and temperature. If needed, legs can be substituted for skirts. Please refer to our options page for information on our Powered Anode system and other items.

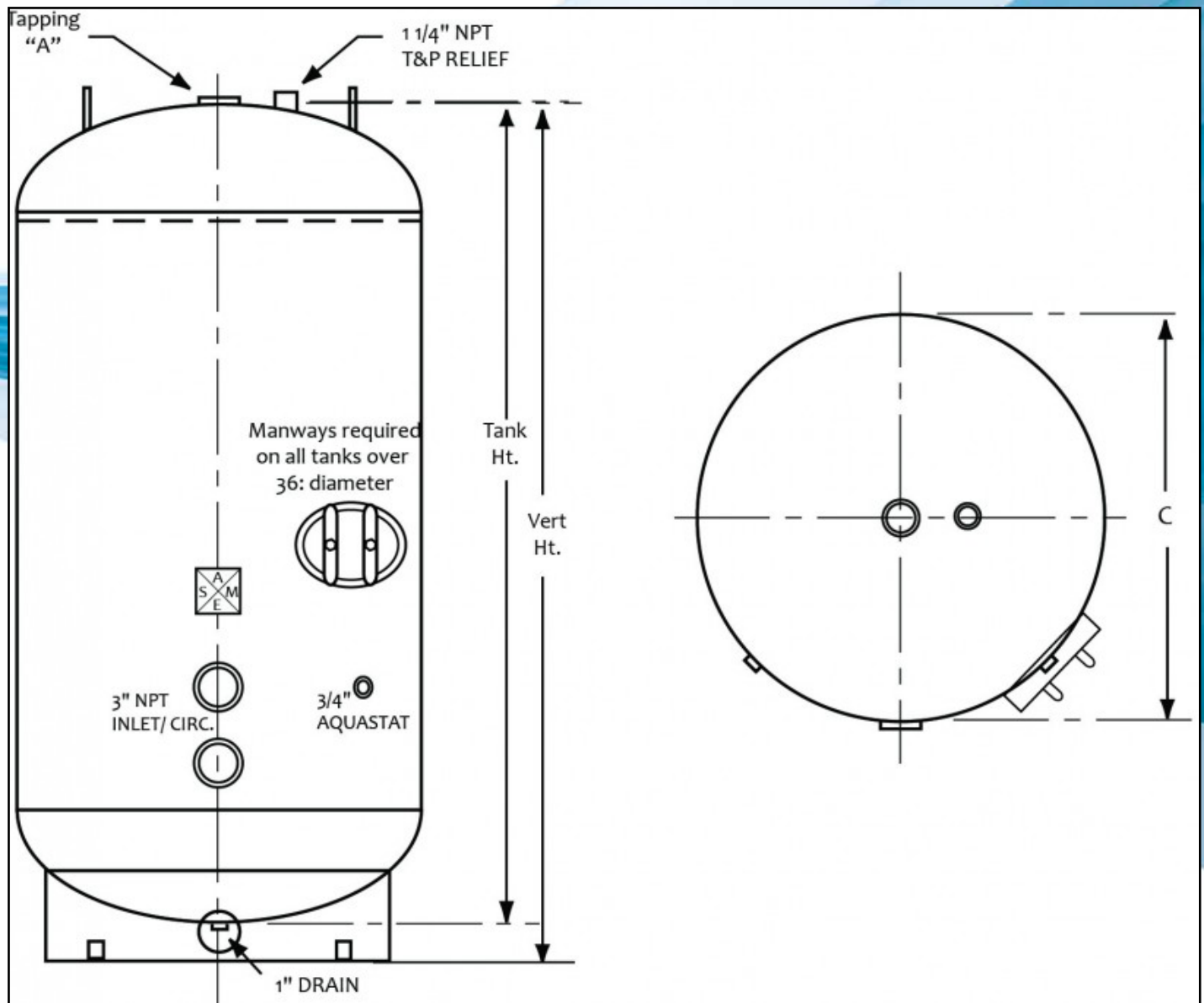



RLU HOT WATER STORAGE TANK

Other size available upon request.

✓	Model Number	Actual Gal. Cap.	Nominal Gal.Cap.	Vertical HT.	Tank.HT.	Base Clr.	DIA.	Tapping "A"	Weight @125#
	RLUV-30-063	175	193	67"	63"	4"	30"	2.5"	340
	RLUV-30-075	210	229	79	75	4	30	2.5	387
	RLUV-30-085	240	260	89	85	4	30	2.5	420
	RLUV-30-099	280	303	103	99	4	30	2.5	483
	RLUV-30-111	320	340	115	111	4	30	2.5	530
	RLUV-36-072	285	317	76	72	4	36	2.5	550
	RLUV-36-078	310	344	82	78	4	36	2.5	588
	RLUV-36-085	340	375	89	85	4	36	2.5	633
	RLUV-36-090	360	397	94	90	4	36	2.5	664
	RLUV-36-102	415	449	106	102	4	36	2.5	742
	RLUV-36-114	465	502	118	114	4	36	2.5	818
	RLUV-36-126	515	555	130	126	4	36	2.5	894
	RLUV-42-081	435	486	85	81	4	42	3	783
	RLUV-42-084	455	504	88	84	4	42	3	805
	RLUV-42-093	505	558	97	93	4	42	3	874
	RLUV-42-105	575	630	109	105	4	42	3	963
	RLUV-42-117	645	702	121	117	4	42	3	1052
	RLUV-42-129	720	774	133	129	4	42	3	1140
	RLUV-42-139	776	834	143	139	4	42	3	1217
	RLUV-48-073	500	572	77	73	4	48	3	1038
	RLUV-48-084	580	658	88	84	4	48	3	1161
	RLUV-48-096	675	752	100	96	4	48	3	1298
	RLUV-48-108	765	846	112	108	4	48	3	1433
	RLUV-48-116	836	909	122	116	4	48	3	1522
	RLUV-48-120	860	940	124	120	4	48	3	1567
	RLUV-48-141	1040	1128	145	141	4	48	3	1805
	RLUV-48-168	1225	1306	174	168	4	48	3	2186
	RLUV-54-099	875	981	105	99	6	54	3	1596
	RLUV-54-113	1000	1119	119	113	6	54	3	1827
	RLUV-54-123	1110	1219	129	123	6	54	3	1889
	RLUV-54-134	1200	1327	140	134	6	54	3	1969
	RLUV-54-147	1340	1457	153	147	6	54	3	2182
	RLUV-54-160	1481	1585	166	160	6	54	3	2402
	RLUV-54-165	1500	1635	171	165	6	54	3	2484
	RLUV-54-183	1690	1814	189	183	6	54	3	2722
	RLUV-60-093	1006	1137	102	96	6	60	3	2007
	RLUV-60-114	1245	1395	120	114	6	60	3	2376
	RLUV-60-138	1530	1689	144	138	6	60	3	2797
	RLUV-60-168	1820	1983	174	168	6	60	3	3210
	RLUV-60-177	2000	2165	183	177	6	60	3	3481
	RLUV-60-186	2105	2276	192	186	6	60	3	3639

See next page for more models.



RLU HOT WATER STORAGE TANK

Other size available upon request.

√	Model Number	Actual Gal. Cap.	Nominal Gal. Cap.	Vertical HT.	Tank. HT.	Base Clr.	DIA.	Tapping "A"	Weight @125#
	RLUV-60-210	2395	2570	216	210	6	60	3	3922
	RLUV-72-094	1500	1655	100	94	6	72	3	2551
	RLUV-72-100	1538	1761	106	100	6	72	3	2677
	RLUV-72-117	1835	2061	123	117	6	72	3	3035
	RLUV-72-120	1865	2115	126	120	6	72	3	3099
	RLUV-72-128	2000	2256	134	128	6	72	3	3267
	RLUV-72-144	2285	2538	150	144	6	72	3	3304
	RLUV-72-157	2535	2765	163	157	6	72	3	3878
	RLUV-72-168	2727	2959	174	168	6	72	3	4110
	RLUV-72-192	3147	3382	198	192	6	72	3	4616
	RLUV-72-216	3567	3805	222	216	6	72	3	5122
	RLUV-72-250	4162	4404	256	250	6	72	3	5616
	RLUV-84-121	2500	2901	127	121	6	84	3	4265
	RLUV-84-138	2915	3310	144	138	6	84	3	4747
	RLUV-84-162	3480	3886	168	162	6	84	3	5428
	RLUV-84-186	4045	4462	192	186	6	84	3	6109
	RLUV-84-210	4610	5038	216	210	6	84	3	6789
	RLUV-84-256	5695	6141	262	256	6	84	3	8094



● Product Specifications RLUH

Flo Fab Tank maintains a large selection of standard Large volume hot water storage tanks in inventory which are available for quick ship. Inventory gallon sizes range from 210 gallon up to 1000 gallons. All tanks are vertical/horizontal, glass lined with oxide primer. Refer to our submittal pages for details on tank fitting configuration. Manways are required on all tanks OVER 36" diameter and our pricing reflects that requirement. Manways are optional on 36" diameter and below. All bare vertical tanks come standard with lifting lugs. Each tank is hydro-tested and independently inspected as ASME regulations require. Need more than what is available in our standard sizes? We can build to your specifications. Fitting changes, flanges, linings and exterior finishes, high pressures are all available but current lead times will apply. Please visit our Get A Quote page and tell us what you're looking for. When ordering or requesting a quotation, please let us know the number of fittings or nozzles, operating pressure and temperature. If needed, legs can be substituted for skirts. Please refer to our options page for information on our Powered Anode system and other items.

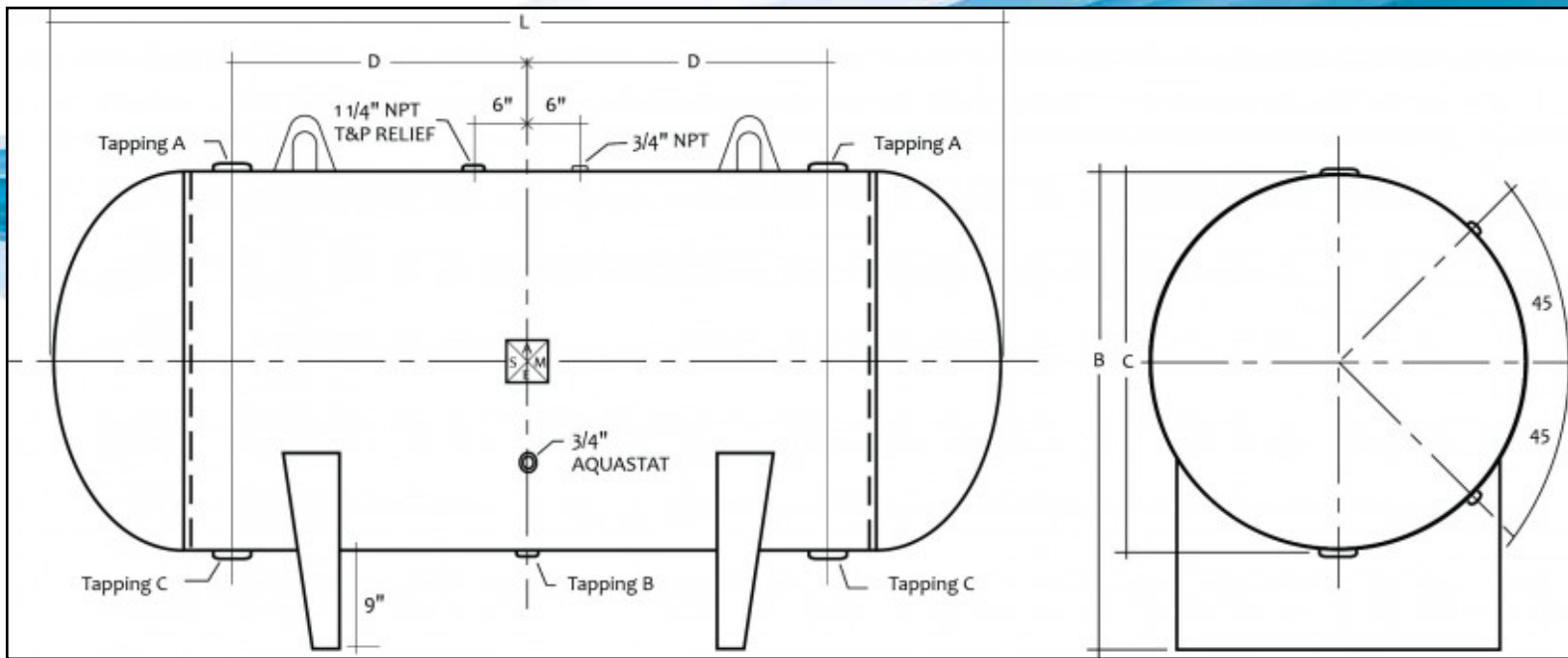



RLU HOT WATER STORAGE TANK

Other size available upon request.

✓	Model Number	Nominal Gal.Cap.	Actual Gal. Cap.	HEIGHT "B"	"L"	"D"	SADDLE CLR.	DIA."C"	Tapping "A"	TAPPING "B"	TAPPING "C"	WEIGHT @125#
	RLUH-30-063	193	175	39"	63"	18"	9"	30"	2.5"	1"	3"	365
	RLUH-30-075	229	210	39	75	24	9	30	2.5	1	3	412
	RLUH-30-085	260	240	39	85	29	9	30	2.5	1	3	545
	RLUH-30-099	303	280	39	99	36	9	30	2.5	1	3	508
	RLUH-30-111	340	320	39	111	42	9	30	2.5	1	3	555
	RLUH-36-072	318	285	45	72	21	9	36	2.5	1	3	576
	RLUH-36-078	344	310	45	78	24	9	36	2.5	1	3	614
	RLUH-36-085	375	340	45	85	27.5	9	36	2.5	1	3	659
	RLUH-36-090	397	360	45	90	30	9	36	2.5	1	3	690
	RLUH-36-102	449	415	45	102	36	9	36	2.5	1	3	768
	RLUH-36-114	502	465	45	114	42	9	36	2.5	1	3	844
	RLUH-36-126	555	515	45	126	48	9	36	2.5	1	3	920
	RLUH-42-081	486	435	51	81	24	9	42	3	1	3	810
	RLUH-42-084	504	453	51	84	25.5	9	42	3	1	3	832
	RLUH-42-093	558	505	51	93	30	9	42	3	1	3	874
	RLUH-42-105	630	575	51	105	36	9	42	3	1	3	963
	RLUH-42-117	702	645	51	117	42	9	42	3	1	3	900
	RLUH-42-129	774	720	51	129	48	9	42	3	1	3	1068
	RLUH-42-139	846	790	51	139	53	9	42	3	1	3	1138
	RLUH-48-073	572	500	57	73	18.5	9	48	3	1	3	1090
	RLUH-48-084	658	580	57	84	24	9	48	3	1	3	1213
	RLUH-48-096	752	675	57	96	30	9	48	3	1	3	1350
	RLUH-48-108	846	765	57	108	36	9	48	3	1	3	1485
	RLUH-48-120	940	840	57	120	42	9	48	3	1	3	1619
	RLUH-48-141	1128	1040	57	141	52.5	9	48	3	1	3	1857
	RLUH-48-168	1316	1225	57	168	52.5	9	48	3	1	3	2160
	RLUH-54-099	981	875	63	99	37.5	9	54	3	1.5	3	1596
	RLUH-54-123	1219	1110	63	123	49.5	9	54	3	1.5	3	2124
	RLUH-54-134	1327	1217	63	134	61.5	9	54	3	1.5	3	2252
	RLUH-54-147	1457	1340	63	147	61.5	9	54	3	1.5	3	2256
	RLUH-54-156	1545	1410	63	156	61.5	9	54	3	1.5	3	2364
	RLUH-54-165	1635	1500	63	165	61.5	9	54	3	1.5	3	2364
	RLUH-54-183	1814	1690	63	183	79.5	9	54	3	1.5	3	2696
	RLUH-60-093	1137	1006	69	93	28.5	9	60	3	1.5	3	2548
	RLUH-60-114	1395	1245	69	114	24	9	60	3	1.5	3	2648
	RLUH-60-138	1689	1530	69	138	48	9	60	3	1.5	3	2829
	RLUH-60-168	1983	1820	69	168	60	9	60	3	1.5	3	3560
	RLUH-60-177	2165	2000	69	177	67.5	9	60	3	1.5	3	3491
	RLUH-60-192	2276	2105	69	192	75	9	60	3	1.5	3	3766

See next page for more models.



RLU HOT WATER STORAGE TANK

Other size available upon request.

✓	Model Number	Nominal Gal.Cap.	Actual Gal. Cap.	HEIGHT "B"	"L"	"D"	SADDLE CLR.	DIA. "C"	Tapping "A"	TAPPING "B"	TAPPING "C"	WEIGHT @125#
	RLUH-72-117	2061	1800	81	117	34.5	9	72	3	1.5	3	3305
	RLUH-72-120	2113	1865	81	120	36	9	72	3	1.5	3	3369
	RLUH-72-128	2254	2000	81	128	40	9	72	3	1.5	3	3540
	RLUH-72-144	2536	2285	81	144	48	9	72	3	1.5	3	3881
	RLUH-72-157	2765	2500	81	157	54.5	9	72	3	1.5	3	4105
	RLUH-72-168	2959	2700	81	168	60	9	72	3	1.5	3	4394
	RLUH-72-192	3382	3115	81	192	72	9	72	3	1.5	3	4852
	RLUH-72-216	3805	3530	81	216	84	9	72	3	1.5	3	5418
	RLUH-72-250	4404	4120	81	250	101	9	72	3	1.5	3	6144
	RLUH-84-121	2901	2500	93	121	32.5	9	84	3	1.5	3	4684
	RLUH-84-138	3308	2915	93	138	41	9	84	3	1.5	3	5196
	RLUH-84-162	3884	3480	93	162	53	9	84	3	1.5	3	5902
	RLUH-84-186	4459	4045	93	186	65	9	84	3	1.5	3	6614
	RLUH-84-210	5035	4610	93	210	77	9	84	3	1.5	3	7327
	RLUH-84-256	6138	5695	93	256	100	9	84	3	1.5	3	8693



● Product Specifications RWUV

Jacketed and insulated tanks are available from our quick ship inventory, however, we need about 3 to 4 days to do the jacketing and insulating. When ordering, please check our current inventory, if the size is available, we'll do our best to get the completed vessel to your door. Alterations of any stock tank is not possible. If you need additional fittings, or changes to our standard fitting design, double glass lining, or other changes or modifications, we would need to build the tank from scratch and standard lead times will apply. - Our jacketed and insulated tanks come standard with 2" of spray foam insulation which meets ASHREA 90.1b (2010 version) requirements. Manways are standard on all tanks over 36" diameter and are optional on 36" diameter and below. Extended lifting lugs can be added to the tank and will protrude out of the top pan and, every tank is mounted on 2" fork-lift rails for easy lifting. All tanks are hydro test and independently inspected prior to jacketing as required by ASME regulations.

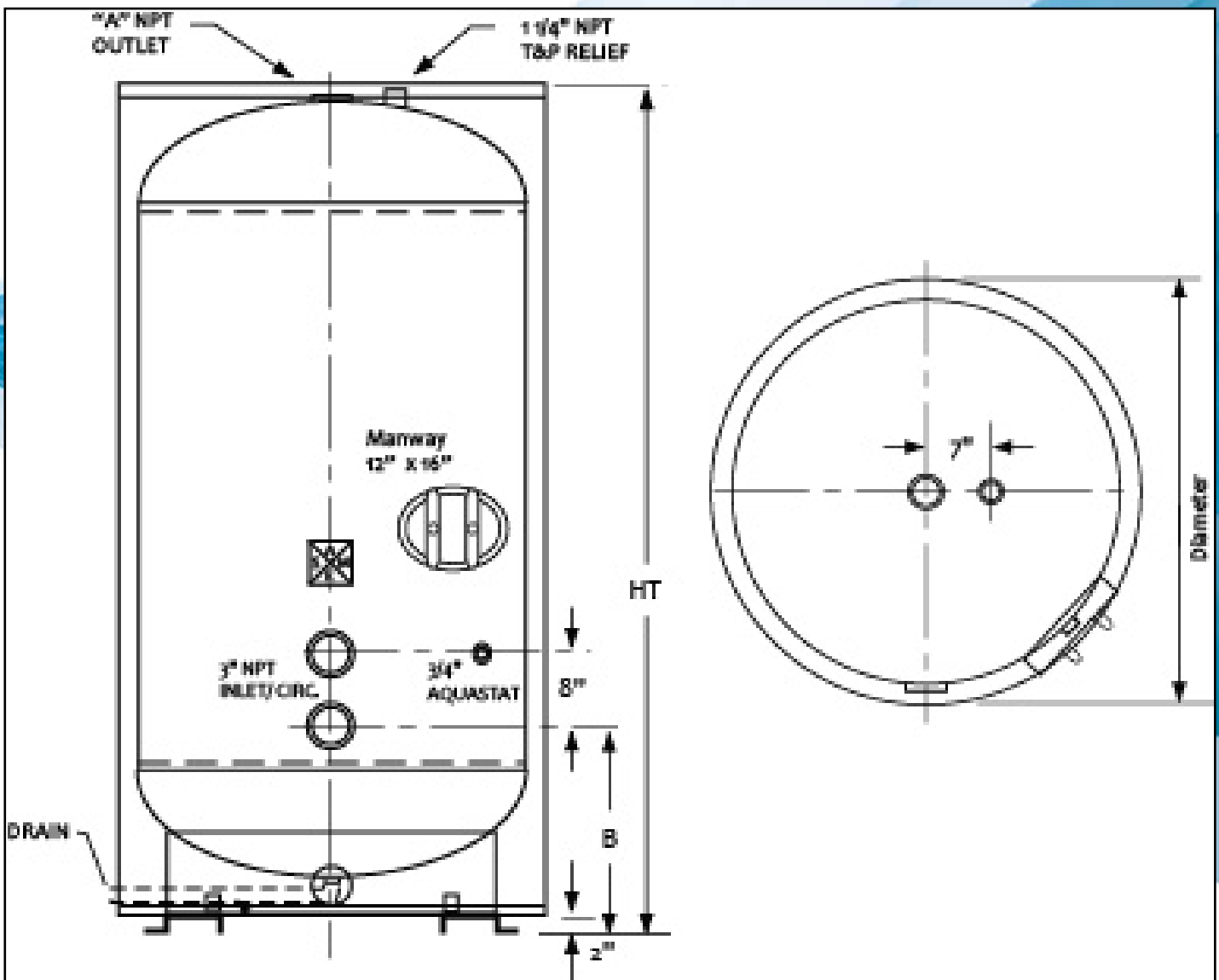



RWU HOT WATER STORAGE TANK

Other size available upon request.

✓	Model Number	Nominal Gal.Cap.	Actual Gal.Cap.	HT	BASE CLEARANCE	"B"	DIAMETER	"A" Hot Out	WEIGHT @125#
	RWUV-20-040		40	47"	Sits on base		20"	3/4"	548
	RWUV-20-050		50	47	Sits on base		22	3/4	130
	RWUV-24-080		80	59	Sits on base	9.25"	24	2	192
	RWUV-24-080A		80	59	Sits on base	9.25	24	2	192
	RWUV-28-120		120	63	Sits on base	9.25	28	2	225
	RWUV-28-120A		120	63	Sits on base	9.25	28	2.5	225
	RWUV-32-200		200	78	Sits on base	16.25	32	2.5	541
	RWUV-30-063	193	175	71	2"	19.5	34	2.5	548
	RWUV-30-075	229	210	83	2	19.5	34	2.5	613
	RWUV-30-085	260	240	93	2	19.5	34	2.5	700
	RWUV-30-099	303	280	107	2	19.5	34	2.5	673
	RWUV-30-111	340	320	119	2	19.5	34	2.5	730
	RWUV-36-072	318	285	80	2	21	40	2.5	714
	RWUV-36-078	344	310	86	2	21	40	2.5	782
	RWUV-36-085	375	340	93	2	21	40	2.5	845
	RWUV-36-090	397	360	98	2	21	40	2.5	894
	RWUV-36-102	449	415	110	2	21	40	2.5	982
	RWUV-36-114	502	465	122	2	21	40	2.5	1106
	RWUV-36-126	555	515	134	2	21	40	2.5	1194
	RWUV-42-081	486	435	89	2	22.5	46	3	1024
	RWUV-42-084	504	453	92	2	22.5	46	3	1074
	RWUV-42-093	558	505	101	2	22.5	46	3	1168
	RWUV-42-105	630	575	113	2	22.5	46	3	1292
	RWUV-42-117	702	645	125	2	22.5	46	3	1392
	RWUV-42-129	774	720	137	2	22.5	46	3	1498
	RWUV-42-139	846	790	147	2	22.5	46	3	1587
	RWUV-48-073	572	500	81	2	24	52	3	1381
	RWUV-48-084	658	580	92	2	24	52	3	1539
	RWUV-48-096	752	675	104	2	24	52	3	1653
	RWUV-48-108	846	765	116	2	24	52	3	1803
	RWUV-48-120	940	840	128	2	24	52	3	1947
	RWUV-48-141	1128	1040	149	2	24	52	3	2216
	RWUV-54-099	981	875	107	2	27.5	58	3	1776
	RWUV-54-113	1119	1000	121	2	27.5	58	3	2900
	RWUV-60-096	1174	1000	104	2	29	64	3	3325
	RWUV-60-114	1395	1245	122	2	29	64	3	3326
	RWUV-60-128	1430	1565	136	2	29	64	3	3501



● Product Specifications RWUH

Jacketed and insulated tanks are available from our quick ship inventory, however, we need about 3 to 4 days to do the jacketing and insulating. When ordering, please check our current inventory, if the size is available, we'll do our best to get the completed vessel to your door. Alterations of any stock tank is not possible. If you need additional fittings, or changes to our standard fitting design, double glass lining, or other changes or modifications, we would need to build the tank from scratch and standard lead times will apply. - Our jacketed and insulated tanks come standard with 2" of spray foam insulation which meets ASHREA 90.1b (2010 version) requirements. Manways are standard on all tanks over 36" diameter and are optional on 36" diameter and below. Extended lifting lugs can be added to the tank and will protrude out of the top pan and, every tank is mounted on 2" fork-lift rails for easy lifting. All tanks are hydro test and independently inspected prior to jacketing as required by ASME regulations. All tanks requiring double glass lined or Flo Fab Defender Epoxy lined are built to order. And, all tank designs are available in 316L or 2205 duplex stainless steel (not available in 40, 50, 80, 80A, 120, 120A or 200 gallon)

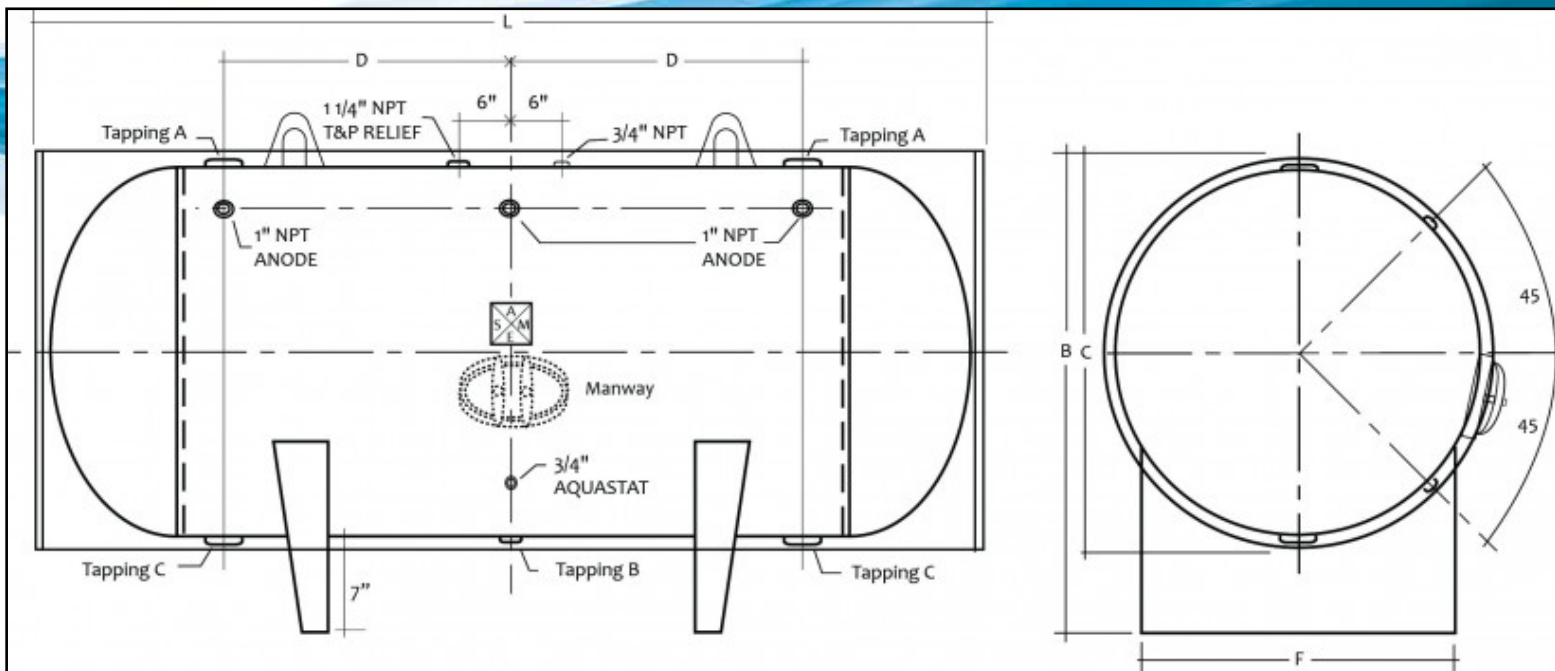



RWU HOT WATER STORAGE TANK

Other size available upon request.

✓	Model Number	Nominal Gal.Cap.	Actual Gal. Cap.	HEIGHT "B"	"L"	"D"	SADDLE CLR.	DIAMETER "C"	TAPPING "A"	TAPPING "B"	TAPPING "C"	WEIGHT @125#
	RWUH-30-063	193	175	41"	67"	18"	7"	34"	2.5"	1"	3"	548
	RWUH-30-075	229	210	41	79	24	7	34	2.5	1	3	613
	RWUH-30-085	260	240	41	89	29	7	34	2.5	1	3	700
	RWUH-30-099	303	280	41	103	36	7	34	2.5	1	3	673
	RWUH-30-111	340	320	41	115	42	7	34	2.5	1	3	730
	RWUH-36-072	318	285	47	76"	21	7	40	2.5"	1	3	714
	RWUH-36-078	344	310	47	82	24	7	40	2.5	1	3	782
	RWUH-36-085	375	340	47	89	27.5	7	40	2.5	1	3	845
	RWUH-36-090	397	360	47	94	30	7	40	2.5	1	3	894
	RWUH-36-102	449	415	47	106	36	7	40	2.5	1	3	982
	RWUH-36-114	502	465	47	118	42	7	40	2.5	1	3	1106
	RWUH-36-126	555	515	47	130	48	7	40	2.5	1	3	1194
	RWUH-42-081	486	435	53	85	24	7	46	3	1	3	1024
	RWUH-42-084	504	453	53	88	25.5	7	46	3	1	3	1074
	RWUH-42-093	558	505	53	97	30	7	46	3	1	3	1168
	RWUH-42-105	630	575	53	109	36	7	46	3	1	3	1292
	RWUH-42-117	702	645	53	121	42	7	46	3	1	3	1392
	RWUH-42-129	774	720	53	133	48	7	46	3	1	3	1498
	RWUH-42-139	846	790	53	143	53	7	46	3	1	3	1587
	RWUH-48-073	572	500	59	77	18.5	7	52	3	1	3	1381
	RWUH-48-084	658	580	59	88	24	7	52	3	1	3	1539
	RWUH-48-096	752	675	59	100	30	7	52	3	1	3	1653
	RWUH-48-108	846	765	59	112	36	7	52	3	1	3	1803
	RWUH-48-120	940	840	59	124	42	7	52	3	1	3	1947
	RWUH-48-141	1128	1040	59	145	52.5	7	52	3	1	3	2216



● Product Specifications **CBT**

Flo Fab's Buffer Tanks are designed for use with Commercial chiller water systems and hydro-nic heating systems which may have insufficient water volume to maintain optimum operating temperature control. Flo Fab offers gallon capacities in 130 gal, 210 gal, 300 gal, 400 gal, 528 gal, and 1040 gal. Additional sizes are also available. Buffer tanks are constructed under the A.S.M.E., Section VIII., Division I code as such are not required to be equipped with a manway. Vertical tank designs are available with a center baffle plate with inlet and outlet on upper shell. The top of the tank has an FNPT port for the air vent; the bottom of the tank has an FNPT drain port. Closed loop systems do not require a manway, but they are available as an option, if desired. Standard product design offering as well as custom configurations with alternate system connections are available. Available connections are Female National Pipe Threads, ANSI Flanges, and Grooved Pipe End connections. R-16 closed cell spray foam insulation is also available. Linings include, Ultonium or Flo Fab Defender Epoxy, if needed. Ultonium lined tanks do not have internal baffles.

Furnish and install as shown on plan, a Flo Fab Steel Tank A.S.M.E. Buffer tank of _____ gallons, _____ diameter with an overall height of _____. The tank must be designed, constructed and stamped 125 psi @ -20F to 450F in accordance with section VIII, Division I of the A.S.M.E. Boiler and Pressure Vessel code and registered with the National Board of boiler and pressure vessel inspections. The buffer tank shall be painted with 1) coat of red oxide shop primer paint. A manufacturers data report for pressure vessels, Form U-1A as required by the provisions of the A.S.M.E. Boiler and Pressure Vessel code shall be furnished for each buffer tank upon request. To properly size the buffer tank, calculate the systems total capacity including all piping and terminal equipment. Subtract that number from the chiller manufacturers recommended system capacity. If a 100 ton chiller requires 1000 gallons of system capacity for high accuracy control and the total piping system totals only 600 gallons, a 400 gallon buffer tank would be required. (As an example) R-16 closed cell spray foam insulation is also available. Linings include, Ultonium or Flo Fab Defender Epoxy, if needed. Ultonium lined tanks do not have internal baffles.

SIZING & SELECTION FOR FLO FAB STEEL TANK CBT BUFFER TANKS:

1. Required Chiller Volume: _____ Gallons
Manufacturer of chiller unit's recommended 'gallons per ton' of cooling. Typical 3 - 6 gallons per ton. Critical accuracy: 6 - 10 gallons per ton.
 2. Actual Gallon Volume in the entire chiller system: _____ Gallons (including piping)
- (1) Chiller requirements gallons: _____ (-) minus (2) Actual gallons in system = _____ gallon size of buffer tank.

Flo Fab Steel Tank manufactures a standard line of vertical and horizontal buffer tanks. Vertical tanks are equipped with an internal baffle and standard flanged connections on 210 gallon and above. Horizontal tanks typically do not have internal baffles, but can be added. Since Flo Fab Steel Tank is a custom tank fabricator, we would be happy to add or change our current design to suit your specific requirements. Grooved pipe end fitting are available in place of flanged connections. Our 2-part, closed cell foam spray on insulation can be added to any size tank and is durable enough for outdoor applications.



Product Specifications

CBT

Buffer tanks are essential components in modern day chiller and heating systems. CBT buffer tanks are designed to increase the systems capacity so water temperatures stabilize within the manufacturers recommendations. When the cooling system piping capacity is under sized, compressors will short cycle and temperature control is harder to maintain within the building. Chiller manufacturers recommend between 3 and 10 gallons per ton of nominal cooling capacity in the piping system, Depending on the level of accuracy of temperature control, higher volumes may be required.

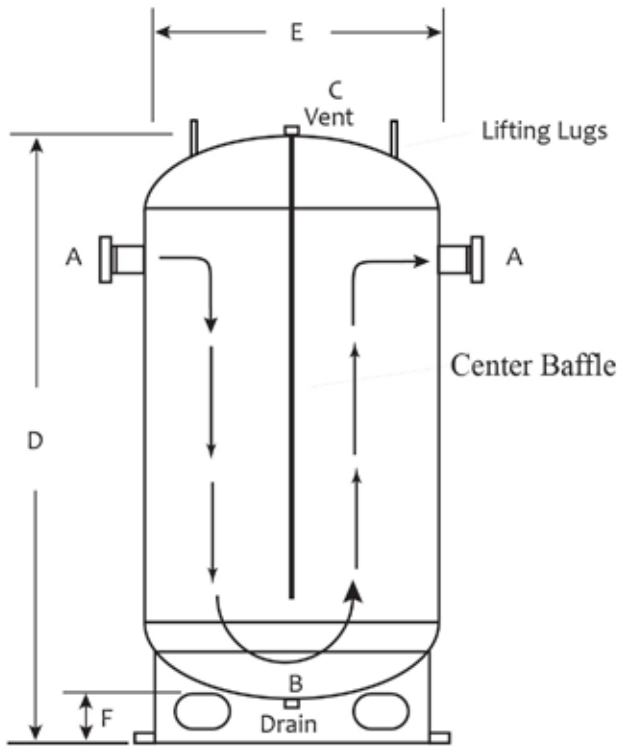

Manways are optional on all closed loop systems

Inlets and outlets can be re-positioned in the shell of the tank if required

All tanks are constructed and certified in accordance with the ASME section VIII, Div. I code

Topcoat Spray foam insulation is available, R-16 value

Red Oxide shop primer on bare tanks

Custom sizes are available

Grooved, Flanged and NPT connections available

Interior linings are available

304 and 316L Stainless Steel is available

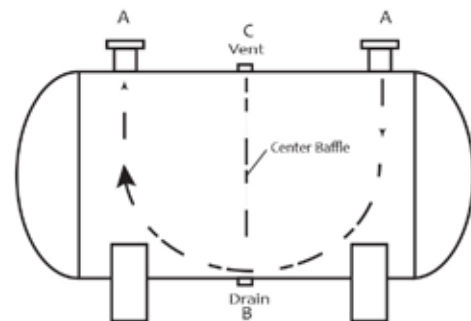

Horizontal buffer tanks are built to order. Consult factory for sizes, dimensions and specifications.

Model	Gal.	A	B	C	D	E	F	Weight
CBT-24-072	130	2" NPT	1"	1"	76"	24"	4"	375
CBT-30-075	210	3" Flg	1"	1"	79"	30"	4"	425
CBT-36-072	300	4" Flg	1"	1"	76"	36"	4"	633
CBT-36-094	400	4" Flg	1"	1"	98"	36"	4"	715
CBT-42-084	460	4" Flg	1"	1"	88"	42"	4"	1250
CBT-48-077	528	6" Flg	1"	1"	81"	48"	4"	1150
CBT-48-090	600	6" Flg	1"	1"	94"	48"	4"	1765
CBT-48-099	700	6" Flg	1"	1"	103"	48"	4"	1885
CBT-48-141	1000	6" Flg	1"	1"	145"	48"	4"	1957
CBT-54-096	850	6" Flg	1"	1"	102"	54"	6"	1630
CBT-60-096	1040	8" Flg	1"	1"	102"	60"	6"	2280

We are proud supplier for the following completed and on going projects :



Las Positas College
3000 Campus Hill Dr,
Livermore, CA, USA
94551



The West Mall
25 The West Mall,
Toronto, ON
M9C 1B8



Baliscus
1075 Grand Héron Boul.,
Saint-Jérôme, QC, CA
J5L 1G2



**Montréal – P.E.T
International Airport,**
975 boul. Roméo-Vachon
Dorval, Quebec, H4Y 1H1

Sales and Service:

Quebec, Canada
Tel. : (450) 621-2995
Fax : (450) 621-4995

Lake Worth
Florida, USA
33467-5749

Toronto, Canada
Tel. : +1 (647) 544-2995

www.flofab.com

SERVICE 24/7 : parts@flofab.com

