



# MODEL # CBT-42-100

## Design Notes

Code..... ASME Section VIII Div 1  
 Design Pressure..... 125 psi  
 Test Pressure..... 163 psi  
 Interior..... None  
 Exterior..... Primed Painted  
 Supports..... Skirt  
 Capacity..... 550 Gal.  
 Weight..... 1550 Lbs.

## Material Specifications

Heads..... Carbon Steel  
 Shell..... Carbon Steel  
 Couplings..... Carbon Steel  
 Flanges..... Carbon Steel  
 Pipe..... N/A  
 Manway..... Optional

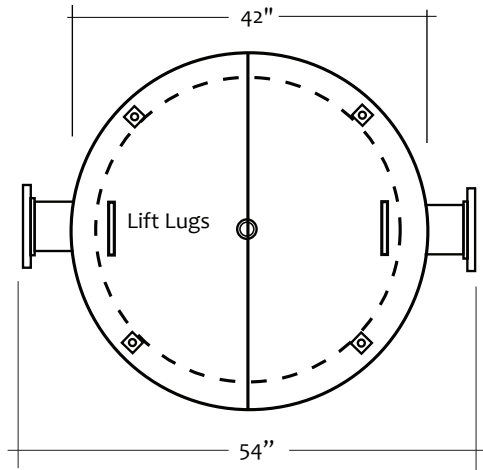

NOTES	

PROJECT	
CUSTOMER	
SCALE	Not to Scale
DATE	
CUSTOMER P.O. #	
DRAWING Rev NO.	

